



# **DIECI**

## **USE AND MAINTENANCE MANUAL**

### ***Hercules 100.10 - 130.10***

*Stage V*



**DIECI S.r.l.** Via E. Majorana, 2-4  
42027 Montecchio Emilia (RE) ITALY  
Tel. +39 0522 869611 Fax +39 0522 869791  
**www.dieci.com** - e-mail: info@dieci.com

**ATTENTION:**

A copy of the following manual must always be available to the operator on the vehicle.



**USE AND MAINTENANCE MANUAL**

Issued by	Document code	Issue date	Review date	Prepared by
Technical Documentation	DOCMA0000120 - Rev. 06	03/2021	07/2022	Technical Documentation

## Original instructions for:

	Vehicle model	Brand	Emission standard	Nominal power	Area	Sector
MFR3203	HERCULES 100.10	FPT	Stage V	125 kW (168 HP)	EC	CONSTRUCTION
MFS3204	HERCULES 130.10	FPT	Stage V	125 kW (168 HP)	EC	CONSTRUCTION

## Standards

This manual is prepared in Italian in accordance with the provisions indicated in the following Standards:

- EN1459-1
- ISO 3600:2015
- ISO 6750:2005
- M.D. 2006/42/EC

Dear Customer,

congratulations and thank you for choosing **DIECI**.

This Use and Maintenance Manual has been written to help you fully appreciate the quality of **DIECI** products.

We strongly recommend that you read this manual in its entirety before using the vehicle.

It contains information, advice and important warnings that will help you to fully take advantage of the technical capabilities of your **DIECI** products.

You will learn about its features and special practical information in addition to information about its maintenance, driver and operation safety to help maintain your **DIECI** products over time.

We are confident that you will be happy with your new purchase and we remain at your disposal should you have any further queries.

Sincerely,

**Sales Management**



[www.dieci.com](http://www.dieci.com)

**Dieci s.r.l.**

VIA E. MAJORANA, 2-4

42027 - MONTECCHIO E. (RE) - ITALY

TEL. ++39 0522-869611

FAX ++39 0522-869744

e-mail: [info@dieci.com](mailto:info@dieci.com)

Fully paid-up share capital € 10.000.000,00

Companies Register R.E. No. 01283560686 - Economic and Administrative Index R.E. No. 204278

Tax Code 01283560686 - VAT no. 01682740350

## 1.1 - General information

Each vehicle is provided with:

- Copy of this manual
- A copy of the use and maintenance manual of the engine prepared by the manufacturer
- A copy of the use and maintenance manual for each device or equipment which is installed on this vehicle.

These manuals have been prepared by the respective suppliers and are faithfully reproduced in full by *DIECI S.R.L.* Behind their specific authorization: they can be enriched with additional specifications drawn up by *DIECI S.R.L.*



### WARNING

All documentation provided is an integral and essential part of the product and must be kept at the disposal of the users; they must carefully read what is written in the above mentioned documentation before using it.



### DANGER

Improper, incorrect or unreasonable use of the vehicle or accessory installed on it is not allowed as also any intervention that alters its structure or operation is not allowed.



### NOTE

**Reproduction of all or part of the contents of this manual and any multimedia attachment.**

*Dieci s.r.l.* will protect the ownership rights of these materials.



### ATTENTION

A copy of this manual must always be available to the operator on the vehicle.

This vehicle has been designed and built as a self-propelled vehicle with operator's seat, wheels, designed for use on paved or natural ground and on uneven ground.

It consists of a main support structure suitable to support the extensible boom.

The head of the boom can be fitted with forks or other equipment only if approved by *Dieci s.r.l.* or only if the manufacturer of the equipment declares that its use conforms with the type of vehicle.

When used normally, the vehicle performs loads lifting and positioning by extending/ retracting, lifting/ lowering the boom.



### WARNING

**Any other use is considered contrary to the intended use by *DIECI s.r.l.* which, therefore, can not be responsible for damage to objects and the vehicle itself, or injury to persons that might derive from misuse.**

For other controls, or complaints to agencies, refer to the applicable local legislation in the country of use of the vehicle.

## 1.2 - Identification of the vehicle

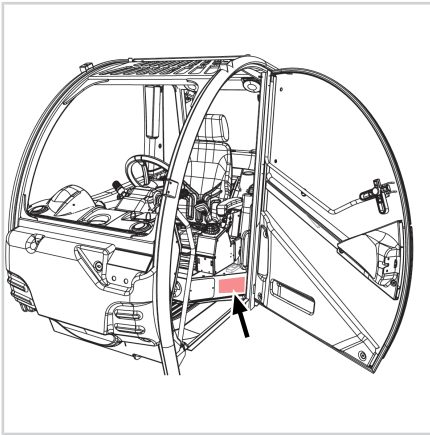

150640-1

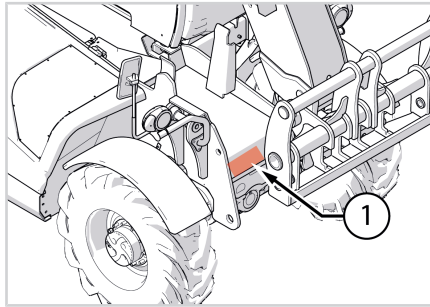

150640-2

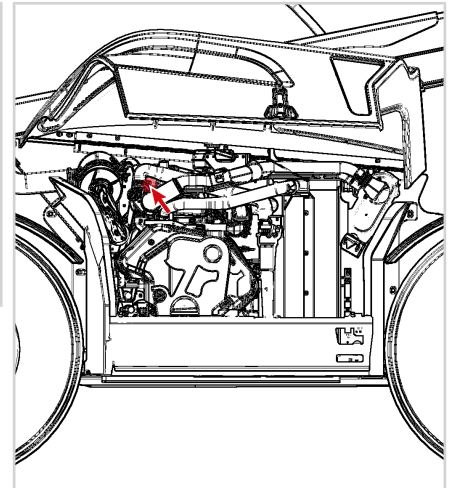

150640-3

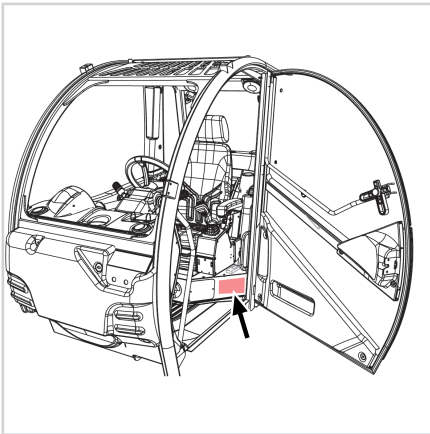

150640-4

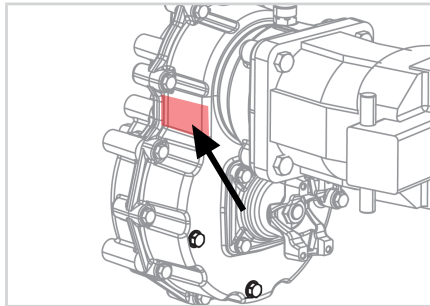

150640-5

Vehicle model (fig. 150640-1)	.....
Year	.....
Serial number of the chassis (fig. 150640-2)	.....
Serial number of the engine (fig. 150640-3)	.....
Serial number of the cab (fig. 150640-4)	.....
Serial number of the transmission gearbox (fig. 150640-5)	.....
Owner / Operator	.....
Address of the Dealer or Agent	.....

	.....
Delivery date	.....
Warranty expiry date	.....

Equipment code	Serial no.	Year
.....	.....	.....
.....	.....	.....
.....	.....	.....
.....	.....	.....



# Table of Contents

<b>1</b>	<b>Info .....</b>	<b>3</b>
1.1	General information.....	5
1.2	Identification of the vehicle .....	6
	<b>Definitions .....</b>	<b>17</b>
<b>2</b>	<b>Introduction .....</b>	<b>18</b>
2.1	Manual structure .....	18
2.2	Purpose and content .....	18
2.3	Preservation .....	18
2.4	Recipients .....	18
2.4.1	Training.....	18
2.4.2	Training.....	19
2.4.3	Qualification.....	19
2.5	Classification of dangers.....	19
2.6	Vehicle general warnings.....	20
2.7	Equipment general warnings .....	21
2.8	Intended use.....	21
2.9	Contraindications for use.....	21
2.10	Declaration of first test.....	21
2.11	Liability.....	21
2.12	Manufacturer .....	22
2.13	Vehicle identification label .....	22
2.14	Certification and CE marking .....	23
2.15	Units of measurement and abbreviations used.....	24
<b>3</b>	<b>Warranty .....</b>	<b>26</b>
3.1	Exclusions from the guarantee .....	26
3.2	Delivery and installation.....	26
3.3	Warranty: duration .....	26
3.4	Warranty: commencement.....	26
3.5	Warranty: activation.....	26
3.6	Warranty procedure.....	27
3.7	Intervention campaigns for faulty products .....	27
3.8	Warranty: intervention request.....	27
3.8.1	Guarantee: claim .....	27
3.8.2	Obligation of vehicle downtime.....	27
3.9	Non-activation, failure to grant, termination.....	27
3.9.1	Warranty: failure to grant.....	27
3.9.2	Guarantee: termination .....	27
3.10	Final terms .....	28
<b>4</b>	<b>Safety regulations.....</b>	<b>29</b>
4.1	General warnings .....	29
4.2	Safety indications.....	30
4.3	Personal protective equipment.....	31

4.3.1	Protective clothing .....	31
4.3.2	Protect yourself against noise .....	31
4.3.3	Protections against objects falling from height.....	32
4.3.4	Protect yourself from flying fragments .....	32
4.4	Preparing for accidents.....	32
4.4.1	First Aider Tasks .....	32
4.4.2	Emergency call .....	32
4.4.3	Traumas .....	33
4.4.4	Hemorrhages .....	33
4.5	Preventing fires and accidents .....	33
4.5.1	Risks of fires .....	33
4.5.2	Risks of inhaling gas .....	34
4.5.3	Risks of batteries exploding .....	34
4.5.4	Residual risks.....	34
4.5.5	Contact with dangerous substances .....	35
4.6	Storing dangerous liquids .....	35
4.7	Warnings for safe working.....	37
4.7.1	Ensuring the vehicle is clean.....	37
4.7.2	Checking for damage .....	37
4.7.3	Start working with the vehicle .....	37
4.7.4	Passengers transportation.....	37
4.7.5	Electrical system protection.....	37
4.7.6	Signals to multiple vehicles.....	39
4.7.7	Working with the danger of falling masses and objects .....	41
4.7.8	Working near electrical lines.....	41
4.7.9	Working under the snow.....	41
4.7.10	Working with scarce lighting.....	42
4.7.11	Working in closed areas or dangerous atmospheres.....	42
4.7.12	Reduce vibrations .....	43
4.8	Working in windy conditions.....	43
4.9	Assessing the consistency of the work ground.....	44
4.10	Moving safely .....	44
4.11	General warnings for moving the load .....	45
4.12	Use of cables, ropes and slings .....	46
4.13	Road travel.....	46
4.13.1	Road travel warnings .....	46
4.13.2	Road travel instructions.....	47
4.14	Momentary stop.....	47
4.15	Parking the vehicle .....	48
4.16	Starting and stopping the vehicle .....	48
4.16.1	General warnings regarding starting up the vehicle .....	48
4.16.2	Inspections prior to starting-up.....	48
4.16.3	Starting-up the engine.....	49
4.16.4	Warm-up after starting-up.....	50
4.16.5	Start-up at low environmental temperatures.....	50
4.16.6	Causes of failed start-ups .....	50
4.16.7	Turn off the vehicle.....	51
<b>5</b>	<b>Vehicle description .....</b>	<b>52</b>
5.1	Left side components description .....	53
5.2	Right side components description .....	54
5.3	Engine components description .....	55
5.4	Cab components description .....	56

<b>6</b>	<b>Safety devices .....</b>	<b>57</b>
6.1	List of safety devices .....	57
6.2	Safety stickers.....	58
6.2.1	Warnings for safety stickers.....	58
6.2.2	Safety stickers position on the vehicle .....	63
6.2.3	Safety stickers position in the cab.....	64
6.2.4	Position of engine safety stickers .....	65
<b>7</b>	<b>Components description .....</b>	<b>66</b>
7.1	Cab .....	66
7.1.1	ROPS - FOPS Cab .....	66
7.1.2	Door opening .....	66
7.1.3	Climbing in/out.....	67
7.1.4	Door glass .....	68
7.1.5	Heated mirrors * .....	68
7.1.6	Rear glass .....	68
7.1.7	Sunshade.....	69
7.1.8	Cab ventilation.....	69
7.1.9	Air conditioning * .....	70
7.1.10	Cab lighting.....	71
7.1.11	12V Socket .....	71
7.1.12	Storage compartment.....	71
7.1.13	Steering wheel .....	71
7.1.14	Multifunction lever .....	72
7.1.15	Lights turning on.....	73
7.1.16	Emergency Lights .....	75
7.1.17	Seat.....	75
7.1.18	Emergency stop.....	78
7.1.19	Spirit Level .....	78
7.1.20	Emergency exit: Rear glass .....	79
7.1.21	Cab front glass protection * .....	79
7.1.22	Warnings in case of vehicle tipping .....	79
7.2	Parking brake.....	80
7.2.1	Parking brake description .....	80
7.2.2	Braking circuit errors list .....	80
7.2.3	Deactivating the internal parking brake manually .....	81
7.3	Instrument panel.....	82
7.3.1	Components .....	82
7.3.2	Initial loading.....	84
7.3.3	Display.....	84
7.3.4	Equipment capacity * .....	84
7.3.5	General alarm icon.....	85
7.3.6	Service .....	85
7.3.7	Clock .....	86
7.3.8	Hour meter .....	86
7.3.9	Transmission Icon .....	86
7.3.10	Low Idle UP icon .....	86
7.3.11	Anti-tipping device ByPass icon .....	86
7.3.12	Seat Switch icon .....	87
7.3.13	Wheels alignment check icon * .....	87
7.3.14	Not connected man basket icon * .....	87
7.3.15	Levelness Icon * .....	87
7.3.16	Hydraulic sockets on boom head icon * .....	87
7.3.17	Accumulation of unburned hydrocarbons (HC) pop up * .....	88
7.3.18	FPT Stage V AdBlue quantity .....	88
7.3.19	Menu.....	88
7.3.20	Info page .....	88

7.3.21	Active errors .....	89
7.3.22	Check page .....	90
7.3.23	Equipment Info page * .....	90
7.4	Electrical steering selector .....	90
7.5	Wheels alignment check * .....	92
7.6	Boom control .....	92
7.6.1	Joystick .....	92
7.6.2	Boom suspension * .....	95
7.6.3	Quick coupling * .....	96
7.7	Hydraulic sockets and electrical contact on boom head * .....	97
7.8	Electrical contact on boom head * .....	98
7.9	Plate translation unit* .....	98
7.10	Equipment quick coupling * .....	98
7.10.1	Quick coupling with single lock on open circuit vehicle .....	99
7.10.2	Quick coupling with double cylinder .....	99
7.11	Safety rod .....	99
7.12	Wheel wedge .....	100
7.13	Block valves .....	100
7.14	Diagrams notebook .....	100
7.14.1	Load Charts .....	100
7.15	Water heater * .....	104
7.16	Transmission .....	105
7.16.1	Movement selection lever * .....	105
7.16.2	Mechanical transmission .....	106
7.16.3	Service braking pedal .....	107
7.16.4	Inching Pedal .....	108
7.16.5	Accelerator pedal .....	108
7.16.6	CREEP mode .....	109
7.17	Remote Control * .....	110
7.17.1	Remote control with levers: Description .....	110
7.17.2	Remote control with joystick: Description .....	115
7.17.3	Remote Control: Use .....	119
7.17.4	Remote Control: Turn off the vehicle and the remote control .....	121
7.17.5	Remote Control: Receiver .....	121
7.17.6	Remote Control: Recharge .....	121
7.17.7	Remote Control: Back-up .....	121
7.17.8	Remote Control: Additional information .....	121
7.18	Automatic differential lock * .....	121
7.19	Automatic axle swing lock .....	122
7.20	Central differential lock .....	122
7.21	Automatic fan reversal .....	123
7.22	Transverse levelling * .....	123
7.23	Boom down control valve * .....	123
7.24	Engine .....	123
7.24.1	AdBlue® .....	123
7.24.2	FPT Series N Stage V engine .....	126
7.25	DPF - Particulate filter regeneration .....	127
7.26	Cameras * .....	128
<b>8</b>	<b>Equipment .....</b>	<b>129</b>

<b>9</b>	<b>Equipment</b> .....	<b>130</b>
9.1	General warnings on equipment use .....	130
9.1.1	Equipment pre-use checks .....	131
9.1.2	Bucket warnings .....	132
9.2	Equipment installation procedure.....	133
9.2.1	Counterplate for Hercules 130.10 .....	135
9.3	Hydraulic connections .....	136
9.3.1	Warnings for hydraulic connections .....	136
9.3.2	Type of hydraulic quick couplings.....	136
9.3.3	References for correct connection.....	136
9.3.4	Push-Pull couplings connection .....	137
9.3.5	Flat-Face couplings connection.....	139
9.3.6	Closed center distributor: Release the pressure through the Pressure relief button * .....	140
9.4	Electrical Connections.....	140
9.4.1	Warnings for electrical connections.....	140
9.4.2	Procedure for connecting electrical connections .....	141
9.5	Equipment removal .....	142
9.5.1	Electrical connections removal .....	142
9.5.2	Push-Pull couplings removal .....	143
9.5.3	Flat-Face couplings removal.....	144
9.6	Forks.....	146
9.6.1	Identification.....	146
9.6.2	Description .....	146
9.6.3	Installation .....	148
9.6.4	Forks check.....	149
9.6.5	Forks use.....	151
9.6.6	Forks adjustment .....	152
9.6.7	Fork extensions.....	153
9.6.8	Forks safe working procedures .....	155
9.7	Bucket.....	158
9.7.1	Buckets identification .....	158
9.7.2	Buckets description.....	158
9.7.3	Buckets safety stickers.....	158
9.7.4	Bucket use.....	158
9.7.5	Fixed tilt indicator use .....	159
9.7.6	Movable tilt indicator use * .....	160
9.7.7	Buckets Safe Working Procedures .....	160
9.8	Equipment lifting .....	162
9.9	Equipment transport .....	162
<b>10</b>	<b>Emergency procedure</b> .....	<b>163</b>
10.1	Emergency procedure list.....	163
10.2	Vehicle towing .....	164
10.2.1	Vehicle towing with electrical panel on.....	164
10.2.2	Towing the vehicle with engine in failure.....	165
10.3	Man basket recovery in case of failure for Hercules.....	165
<b>11</b>	<b>Maintenance</b> .....	<b>168</b>
11.1	Maintenance warnings .....	168
11.1.1	Avoid accidents during maintenance .....	168
11.1.2	Personal protective equipment for maintenance.....	170
11.2	Preliminary maintenance operations .....	171
11.2.1	Prepare the vehicle in the "Maintenance position" .....	171
11.3	Engine hood opening.....	171

11.4 Under chassis protection plate removal.....	172
11.5 Battery.....	172
11.5.1 Low maintenance batteries.....	173
11.5.2 "Zero" maintenance batteries.....	173
11.5.3 Battery: Instructions for recharging.....	173
11.5.4 Battery isolation switch.....	173
11.5.5 Battery: Replacement .....	174
11.5.6 Start up with auxiliary batteries.....	174
11.6 Fuel.....	175
11.6.1 Specifications for recommended fuel .....	175
11.6.2 Cleaning and storing fuel.....	175
11.6.3 Refueling .....	176
11.6.4 Fuel tank: Cleaning .....	176
11.7 AdBlue (Urea) system maintenance.....	176
11.7.1 AdBlue filling .....	176
11.8 Safety stickers: Inspection.....	177
11.9 Lubrication .....	177
11.10 Engine maintenance.....	177
11.10.1 Belts: Check and adjustment .....	178
11.10.2 Fuel filter: Replacement.....	178
11.10.3 Engine oil filter: Replacement.....	178
11.10.4 Engine oil: Check and filling up.....	178
11.11 Air filter: Cartridges cleaning and replacement.....	178
11.12 Radiator maintenance.....	180
11.12.1 Air recirculation grids and nets.....	180
11.12.2 Radiator: Checking and cleaning.....	180
11.12.3 Radiator: Liquid filling up and replacement.....	181
11.13 Hydraulic system maintenance .....	181
11.13.1 Hydraulic oil: Check and replacement.....	181
11.13.2 Hydraulic oil intake filter: Replacement.....	182
11.13.3 Hydraulic oil return filter .....	183
11.13.4 Hydraulic oil filter .....	183
11.14 2 speed transmission maintenance.....	184
11.14.1 Oil change: Inspection.....	184
11.14.2 Oil change: Check and replacement .....	184
11.15 Brakes maintenance.....	184
11.15.1 Brake: Inspection .....	184
11.15.2 Brake: Coolant level check.....	184
11.16 Wheel maintenance .....	185
11.16.1 Epicycloidal reduction gear oil: Check and replacement .....	185
11.16.2 Wheel nuts tightening .....	185
11.16.3 Tires.....	186
11.17 Lighting .....	188
11.17.1 Headlight .....	188
11.17.2 Tail light.....	189
11.17.3 Work light * .....	189
11.17.4 Led work light*.....	190
11.18 Window washer fluid tank.....	190
11.19 Ventilation system maintenance.....	191
11.19.1 Cab ventilation filter: Cleaning and replacement .....	191
11.19.2 Air conditioning: Cleaning * .....	192
11.20 Boom maintenance.....	192
11.20.1 Sliding blocks maintenance .....	192

11.20.2 Boom lubrication with grease .....	192
11.21 Cylinders block valves maintenance.....	193
11.22 Differential Axles Maintenance .....	195
11.22.1 Differential axles oil: Check and replacement .....	195
11.23 Hydraulic fittings tightening torques .....	196
11.24 Torque specifications - fasteners.....	197
11.24.1 Torque specifications - fasteners: Fine pitch.....	197
11.24.2 Torque specifications - fasteners: Coarse pitch.....	199
<b>12 Technical assistance service.....</b>	<b>201</b>
12.1 Spare parts supply .....	201
12.2 Assistance to owner / operator .....	201
12.3 Technical Assistance Service address .....	201
<b>13 Problems diagnostics .....</b>	<b>202</b>
13.1 Engine .....	202
13.2 Hydraulic transmission system .....	202
13.3 Brakes .....	203
13.4 Steering wheel .....	203
13.5 Telescopic boom .....	203
<b>14 Cleaning.....</b>	<b>205</b>
14.1 Vehicle cleaning .....	205
14.2 Glasses cleaning .....	205
14.3 Cleaning the cab .....	205
14.4 Safety stickers cleaning.....	205
<b>15 Lifting the vehicle .....</b>	<b>206</b>
<b>16 Transporting the vehicle on a trailer.....</b>	<b>207</b>
<b>17 Storing the vehicle.....</b>	<b>208</b>
17.1 Long period of inactivity .....	208
17.2 Long period of inactivity .....	208
17.3 Restarting the vehicle.....	208
<b>18 WASTE DISPOSAL.....</b>	<b>209</b>
18.1 Ecological considerations .....	209
18.2 Protect the environment.....	209
<b>19 Demolition.....</b>	<b>210</b>
<b>20 Hydraulic diagram .....</b>	<b>211</b>
20.1 Components legend .....	211
20.2 Diagram .....	213
<b>21 Technical data .....</b>	<b>214</b>
21.1 Hercules 100.10 - 130.10.....	214
21.1.1 Dimensions.....	214
21.1.2 Performance.....	215
21.1.3 Engine .....	215
21.1.4 Weights.....	216
21.1.5 Electrical and hydraulic system.....	216

21.1.6	Transmission .....	217
21.1.7	Axles.....	217
21.1.8	Acoustic pressure.....	217
21.1.9	Acoustic power .....	218
21.1.10	Vibration.....	218
21.1.11	Filling.....	218
21.1.12	Tires data.....	223
21.1.13	Equipment.....	224
21.1.14	Equipment.....	226
21.2	Environmental conditions .....	228
21.3	Electromagnetic Interference.....	228
21.4	Radiations .....	228
21.5	Forks technical data .....	229
21.6	Buckets technical data .....	230
<b>22</b>	<b>Load Charts.....</b>	<b>232</b>
22.1	Load charts Hercules 100.10 .....	234
22.2	Load charts Hercules 130.10 .....	237
<b>23</b>	<b>Control and maintenance logs.....</b>	<b>239</b>
23.1	Type of logs.....	239
23.1.1	Control log.....	239
23.1.2	Maintenance Log .....	239
23.2	Instructions for compiling the logs .....	239
23.2.1	Warnings on the control log .....	239
23.2.2	Warnings on the maintenance log .....	239
23.2.3	Logs compiling .....	239
23.2.4	Logs legend.....	240
23.2.5	Intervals legend .....	241
23.3	Periodic checks and recording mode (Italian only) .....	242
23.4	Obligation and how to report to I.N.A.I.L. (National institute for insurance against accidents at work) (Italy only) .....	242
23.5	Control log.....	243
23.6	Maintenance log .....	253



## Definitions

### Attachment holding plate

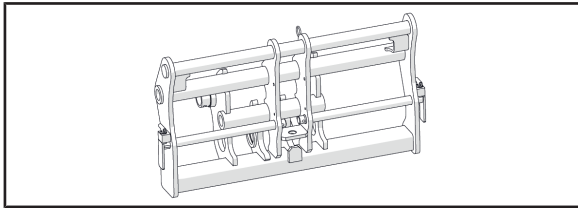

The attachment holding plate is the interface between the vehicle (telehandler) and the interchangeable equipment. The attachment holding plate is placed at the end of the telescopic boom and is used for the quick and safe installation of the interchangeable equipment at the vehicle base.

### Back

The back is the side that is in back of the operator in the control position during the normal forward travel of the vehicle.

### Equipment

The equipment is an interchangeable device that can be installed by the operator on the attachment holding plate of the vehicle, in order to change the function of the vehicle.

### Front

The front is the side that is in front of the operator in the control position during the normal forward travel of the vehicle.

### Generic maintenance technician

Trained and educated person to perform routine maintenance interventions with basic mechanical, electrical and hydraulic knowledge.

### Left side

The left side is the side that is located to the left of the operator in the control position during the normal forward travel of the vehicle.

### Operator

Instructed person, trained with specific theoretical-practical course concerning use of the vehicle or equipment.

### Right side

The right side is the side that is located to the right of the operator in the control position during the normal forward travel of the vehicle.

### Specialized maintenance technician

Trained and educated person to perform routine and extraordinary maintenance interventions with in-depth and specific mechanical, electrical and hydraulic knowledge, normally sent or authorized by DIECI s.r.l. or the dealer.

### Tool

Category of interchangeable equipment not provided with movable parts such as forks or buckets. No CE marking is required for tools.

### Vehicle

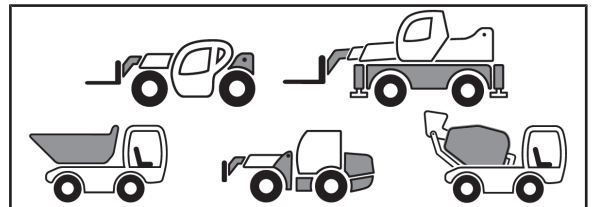

Vehicle means a work vehicle provided with an engine for operation. The term "vehicle" or "basic vehicle" are indistinctly used.

## 2.1 - Manual structure

This manual is an integral part of the official documentation of the Vehicle, Equipment and Tool. It must be carefully stored and be available to the managers, the users and personnel in charge of maintenance.

## 2.2 - Purpose and content

This manual is an integral part of the official documentation and is aimed at supplying the Operator with all the information required concerning technical aspects, operation and safety during the entire lifespan of the vehicle or equipment.



### ATTENTION

This manual should be read carefully before the first use or before maintenance.



### NOTE

If in doubt on the correct understanding of the instructions, contact the Manufacturer for clarifications.

## 2.3 - Preservation

The instruction manual must be kept near the equipment available to the Users (in the cab or on the equipment where set up) inside a dedicated envelope, protected from liquids and anything that might make it illegible.

If the manual becomes creased and/or be, even partially, damaged or illegible or in case of loss of the manual, it must be replaced immediately by contacting the **Dieci Technical Assistance Service**, giving the details of the manual found on the first page of the manual.

## 2.4 - Recipients

This manual is addressed to the following persons:

- Operator : instructed person, trained with specific theoretical-practical course concerning use of the vehicle or equipment
- Generic maintenance technician : trained and educated person to perform routine maintenance interventions with basic mechanical, electrical and hydraulic knowledge

- Specialized maintenance technician : trained and educated person to perform routine and extraordinary maintenance interventions with in-depth and specific mechanical, electrical and hydraulic knowledge, normally sent or authorized by **DIECI s.r.l.** or the dealer.



### ATTENTION

The users must not carry out operations reserved for maintenance technicians or qualified technicians. The Manufacturer is not liable for damage deriving from the non-compliance with this prohibition.

## 2.4.1 - Training

This manual gives the users all technical data on the vehicle or on the equipment, the presence and type of control and safety devices and the presence and meaning of the safety stickers and plates.

All vehicle or equipment users must have all necessary information, training and education in relation to the correct use conditions of the means and foreseeable anomalous risks.

The information, training and educating must be implemented upon introduction of new work equipment and for each work equipment available to users.



### NOTE

Ensure to respect the current laws and Standards in the selling country of the vehicle with regard to information, training and educating of personnel to use the vehicle and its equipment.

The employer is obliged to inform personnel on the following topics related to safety during use:

- Risk of injury
- Vehicle and equipment safety devices set up for operator safety
- Individual safety devices set up for operator safety
- General accident-prevention rules and/or foreseen by international directives
- Accident-prevention rules of Legislation of the Country where the vehicle or the equipment is intended for use

The operator, before starting the work, must know the characteristics of the vehicle and equipment and must have fully read this Use and Maintenance Manual.

**2.4.2 - Training**



**ATTENTION**

The operator in charge of using the vehicle or equipment must have attended a suitable theoretical-practical course lasting as long as indicated by legal prescriptions in the Country where the vehicle or equipment is used.

Training must at least include the following subjects:

- Use and limits of the operation and emergency controls of the equipment and of the vehicle on which the equipment is mounted
- Knowledge and awareness of the Use and Maintenance Manual and of the control marks, of the instructions and of the warnings applied on the vehicle
- Knowledge and understanding of the Standard on this equipment, including the educating aimed at recognizing and avoiding potential dangers at work
- Knowledge of the mechanical operation of the vehicle sufficient for recognizing a real or potential failure
- Hints on constructive particulars of the vehicles and on static and dynamic stability concepts
- Correct use of the vehicle procedures in safe conditions with regard to the work place and the load to be handled/lifted, capacity and guide notions
- Knowledge and use of the PPE to be worn during use of the vehicle and of the equipment
- Knowledge and execution of the routine maintenance to be carried out

Training must be carried out under the supervision of a qualified person in an open area and free from obstacles. At the end of this practice, the trainee must be able to safely use the equipment, and the vehicle on which it is installed.

The operator must also be trained on the responsibility and authority of not using the vehicle or equipment in case of failure or presence of unsafe conditions, and request further information from the Manufacturer or authorized dealer.

**2.4.3 - Qualification**

The vehicle and equipment are intended for professional use; their use must therefore be entrusted to qualified figures, in particular:

- Being of adult age
- Be physically and psychically suitable to carry out particularly difficult technical work

- Have been adequately trained on the use and maintenance of the vehicle and equipment
- Have been judged suitable by the employer to carry out the work entrusted to them
- Are able to understand and interpret the manual and the safety requirements
- Know the emergency procedures and their activation
- Have the ability of activating the specific type of vehicle or equipment
- Are familiar with the specific standards of the case
- Have understood the operational procedures defined by the Manufacturer of the vehicle or equipment

**2.5 - Classification of dangers**

Carefully read the safety regulations given and follow all recommended precautions in order to avoid potential risks and safeguard your health and safety.

The symbols listed below are inserted to highlight situations which **DIECI S.R.L.** considers particularly important.

If in doubt, contact your agent or dealer.



**DANGER**

It indicates an imminently hazardous situation which, if not avoided, could result in death or serious injury.



**WARNING**

It indicates a potentially hazardous situation which, if not avoided, could result in death or serious injury.



**ATTENTION**

It indicates a potentially hazardous situation which, if not avoided, could result in minor or moderate injury.

**ATTENTION**

Used without the safety warning symbol, it indicates a potentially hazardous situation which, if not avoided, could result in property damage.

**NOTE**

It indicates information or a company policy that relates directly or indirectly to personnel safety or to property protection.

**NOTE**

It indicates an optional accessory or attachment.

## 2.6 - Vehicle general warnings

Every vehicle or equipment comes with a copy of its own manual.

**ATTENTION**

Reproduction of all or part of the contents of this manual or of the multimedia attachment, if any, is prohibited.

*Dieci s.r.l.* will protect the ownership rights of these materials.

**ATTENTION**

It is compulsory to read and understand this manual before using the vehicle or various equipment and to carefully follow the indications therein. The instructions for use, maintenance and repair described in this handbook must be followed if the vehicle is to be considered as being operated in accordance with the manufacturer's intended uses.

**NOTE**

*DIECI s.r.l.* reserves the right to carry out possible modifications to the vehicle or equipment for technical or commercial reasons without prior notice.

- A copy of the use and maintenance manual relative to vehicle parts or equipment of the respective suppliers can be supplied. These

manuals are written by the respective product suppliers and reproduced accurately and in full by *DIECI s.r.l.* with their specific authorization: they can be enhanced with further specifications drawn up by *DIECI s.r.l.*

- This Use and Maintenance manual is also provided by the Dealer upon delivery of the vehicle, in order to make sure that these instructions are read and correctly understood. Should you have trouble understanding any part of this manual, do not hesitate to contact your nearest Dealer for clarification.
- All documentation provided constitutes an integral and important part of the product and must always be available to users.
- The instructions for use, maintenance and repair described in this handbook must be followed if the vehicle is to be considered as being operated in accordance with the manufacturer's intended uses.
- This manual assumes that the health and safety standards in the work place, in force in the place of use of the vehicle and of the equipment, are complied with.
- This Use and Maintenance Manual in the user's language, must be carefully stored on the vehicle at all times in an accessible and well known place to all users. If the manual becomes creased and/or be, even partially, damaged or illegible or in case of loss of the manual, it must be replaced immediately by contacting the Dieci Technical Assistance Service, giving the details of the manual found in the "Introduction" chapter.
- Improper, incorrect, or irrational use of the vehicle or the accessories with which it is equipped as well as modification to its physical structure or operation is prohibited. A different use is strictly prohibited and relieves *DIECI s.r.l.* from responsibility for damage caused to persons, things or animals.
- *DIECI s.r.l.* is not liable for damage caused by negligent use of this vehicle or the accessory even if said damage is not a result of intentional improper use. Everything possible has been done during the design and construction phases of vehicles and accessories to make your job as safe as possible. Due caution, however, is indispensable and there is no better rule to prevent accidents.
- To correctly use the components and vehicle controls recalled in the following pages, refer to the specific use and maintenance manual of the vehicle.

- If the vehicle or the equipment must be used in particularly severe conditions (for example: In dusty environments or worksites, on argillaceous or muddy terrain), we advise consulting your nearest dealer for specific instructions. Failure to observe these instructions may result in the vehicle's guarantee being voided.



### WARNING

For your safety and the safety of others, do not change the structure or adjustment of the various components of the vehicle or equipment.



### NOTE

The right and left positions indicated in this manual refer to the view of the operator sitting in the driver's seat (looking forwards).

## 2.7 - Equipment general warnings



### WARNING

**Only equipment CE certified by the relative manufacturer can be used on DIECI vehicles, as well as equipment approved or falling within the technical limits set out by DIECI S.r.l.**

Before commissioning any kind of accessory make sure about its compatibility with the operating vehicle and about the calibration of the safety system related to the accessory used.

*DIECI S.r.l.* liability shall not be involved if equipment use or modifications do not comply with the above mentioned requirements.

## 2.8 - Intended use

The vehicle or equipment described in this document must be used only for the purposes set out in this Use and Maintenance manual.

Adherence to and strict compliance with the terms of use, repair and maintenance, as specified by the Manufacturer, are essential elements covered by the intended use.



### WARNING

The vehicle and equipment must be used **ONLY** by trained and qualified personnel who is aware of the information contained in this Manual.

## 2.9 - Contraindications for use

The vehicle or equipment must **NOT** be used:

- For recipients other than those listed in the "Recipients" chapter
- For uses other than those mentioned in this manual
- In environmental conditions other than those listed in chapter "Environmental Conditions"
- In use on the road, use the vehicle only if in possession of a valid driver's license in accordance with the regulations in force in the country of use
- Do not use the movable hydraulic parts of the vehicle to lift persons (except with special man baskets)



### NOTE

For any other use of the vehicle or equipment, other than those mentioned above, the Manufacturer will reserve the right to revise the terms of the warranty.

## 2.10 - Declaration of first test

### Manufacturer's declaration of first test

*DIECI s.r.l.* declares that each vehicle and equipment manufactured at its plants, before placing on the market, has been subjected to static and dynamic tests designed to verify proper operation and compliance with EU directives to which it is subject.

At the conclusion of the tests performed, the CE certification of the tested vehicle will be issued.

Each *DIECI s.r.l.* product with CE marking is provided with the related certificate, which must be kept by the rightful owner according to the requirements of law.

## 2.11 - Liability

- The vehicles and equipment are built according to the EC Directives in force at the time of sale;

- Failure to follow the instructions for use and safety or the use of the vehicle in good working order can not cause accidents criminal offense;
- The manufacturer is not liable for damage caused to persons, animals or property resulting from improper use of the vehicle or equipment or from unauthorized structural changes, applications, and transformations;
- The Manufacturer also reserves the right to make any changes to the vehicle or equipment for any technical and commercial requirement without notice.

## 2.12 - Manufacturer

### DIECI s.r.l.

Via E. Majorana, 2/4  
 42027 Montecchio Emilia (RE) ITALY  
 Tax Code 01283560686 VAT No. 01682740350  
 Tel. +39 0522 869611 - Fax +39 0522 869744  
 email: info@dieci.com

## 2.13 - Vehicle identification label

The identification label (fig. 160550-1) shows the main identification data of the vehicle

**NOTE! Refer to the "Identification" chapter of the vehicle use and maintenance manual to know the position of the label in the cab.**

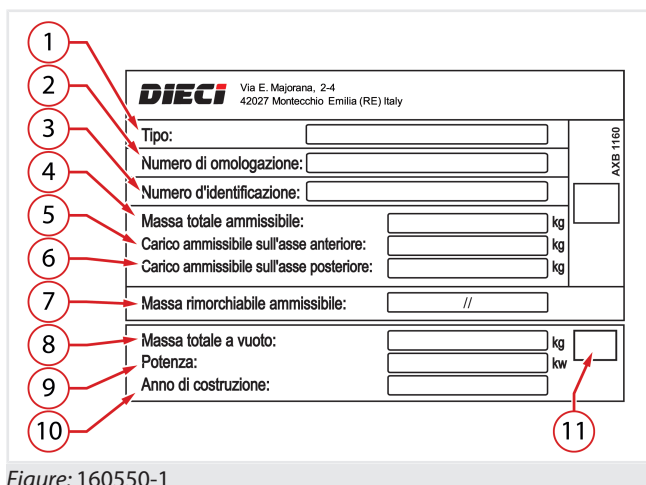

Figure: 160550-1

1	Type	.....
2	Homologation number	.....

3	Identification number	.....
4	Total permissible mass (kg)	.....
5	Permissible load on the front axle (kg)	.....
6	Permissible load on the rear axle (kg)	.....
7	Permissible towable mass (kg)	.....
8	Total unladen mass (kg)	.....
9	Power (kW)	.....
10	Year of construction	.....
11	CE Marking (if installed)	.....

To ensure a prompt and efficient service when ordering parts or when requesting information or technical clarification always specify the identification details.

Therefore we recommend to note the data relating to the accessory in your possession in order to safely and quickly identify them in the future, in case of need.

## 2.14 - Certification and CE marking

The vehicle and related equipment are manufactured in accordance with the relevant EU directives and applicable at the time of its release on the market.

The analysis of all the essential safety health and requirements was carried out during the design and construction in order to verify the applicability and the consequent compliance. Where the analysis has detected an initial lack of conformity, the problems were corrected with appropriate solutions in order to satisfy these requirements.

Here following is shown a facsimile of the certification attached to the vehicle.



---

DECLARATION OF CONFORMITY



(Directive on Machinery 2006/42/CE, annex II, part A – EMC Directive 2014/30/UE, annex IV)

**Product model:** \*\*\*\*\*

**Name and address of the manufacturer:** DIECI S.r.l., Via E. Majorana, 2-4- 42027 Montecchio Emilia (RE), Italia

**This declaration of conformity is issued under the sole responsibility of the manufacturer.**

**Object of the declaration:**

The Telescopic Handler Type \*\*\* \*\* (\*\*\*\*\* ) Serial No ZNV\*\*\*\*\*

**The object of the declaration described above is in conformity with the relevant Union harmonisation legislation:**

- Machinery Directive - 2006/42/CE
- Electromagnetic compatibility" Directive - 2014/30/UE
- Noise emission" Directive - 2000/14/CE procedura allegato VIII

**The notified body Dir.2000/14/CE:** NB 0477 – EUROFINS Product Testing Italy srl - Via Cuorgnè 21, 10156 Torino

**Additional information:**

**Signed for and on behalf of:**  
Mr. ENNIO MANGHI  
to DIECI S.r.l. - Via E. Majorana, 2-4 - 42027 Montecchio Emilia (RE), Italia

Net installed power: \*\* kW

Level of acoustic power measured:  $L_{WAm} = 10^* dB_{(A)}$   
**Level of acoustic power guaranteed:**  $L_{WA} = 10^* dB_{(A)}$ .

CE marks plate on the machine.

Montecchio Emilia, \*\*,\*\*.20\*\*

DIECI SRL  
Via E. Majorana, 2 -4  
Montecchio Emilia (RE)  
An Administrator  
Ennio Manghi



**Dieci Srl**  
Via E. Majorana, 2-4 • 42027 Montecchio Emilia • (Reggio Emilia) ITALY  
Tel. ++39 0522 869611 - Fax ++39 0522 869798 (Reception) - Fax ++39 0522 869797 (Amm.ne)  
[www.dieci.com](http://www.dieci.com) • E-mail: [info@dieci.com](mailto:info@dieci.com)  
Cap. Soc. Int. Vers. € 10.000.000,00 Reg. Impr. R.E. N. 01283560686 R.E.A. R.E. N. 204278 - C.F. 01283560686 • P.I. 01682740350



## 2.15 - Units of measurement and abbreviations used

DECIMAL METRIC SYSTEM (IS)		ENGLISH IMPERIAL SYSTEM (IMP)	
NAME	SYMBOL	NAME	SYMBOL
<b>SURFACE</b>			
square meter	m <sup>2</sup>	square foot	ft <sup>2</sup>
<b>ELECTRICITY</b>			
Ampere	A		
Volt	V		
<b>FORCE</b>			
kiloNewton	kN		
Newton	N		
<b>FORCE TIMES LENGTH - TORQUE</b>			
Newton·meters	N·m	pounds inch	lb·in
<b>FORCE TIMES SURFACE AREA - PRESSURE</b>			
kilopascal	kPa	pound/square inch	psi
<b>ROTATION FREQUENCY</b>			
Revolutions per minute	rpm		
<b>LENGTH</b>			
kilometer	km	mile	mi
meter	m	foot	ft
centimeter	cm	inch	in
millimeter	mm	inch	in
<b>MASS</b>			
kilogram	kg	pound	lb
ton	t	pound	lb
<b>POWER</b>			
kilowatt	kW	horse power	hp
Watt	W		
<b>TEMPERATURE</b>			
degrees Celsius	°C	degrees Fahrenheit	°F
<b>SPEED</b>			
kilometers per hour	km/h	miles per hour	mph
meters/second	m/s	feet/second	ft/s
<b>VOLUME</b>			
cubic meter	m <sup>3</sup>	cubic yard	yd <sup>3</sup>
		cubic inch	in <sup>3</sup>
liter	l	UK gallon	UK gal
<b>TIME</b>			
hour	h	hour	h
minute	min	minute	min
second	s	second	s



**VOLUME TIMES TIME**

cubic meter per minute	m <sup>3</sup> /min	cubic foot per minute	ft <sup>3</sup> /min
liter per minute	l/min	UK gallon per minute	UK gal <sup>3</sup> /min

**SOUND POWER AND ACOUSTIC PRESSURE**

decibel	dB		
---------	----	--	--

## 3.1 - Exclusions from the guarantee

The guarantee does not include:

- All consumables and those subject to normal wear and tear (e.g. batteries, clutch/brake discs, lubricants, filters, belts, fuel ...);
- All consumables such as oil and liquids;
- Damages and/or breakages deriving from failure to comply with/implement the operations recommended in the periodic maintenance programs illustrated in the "Use and maintenance manual";
- Damage caused by incorrect repair carried out by unauthorized workshops/personnel;
- Damages for lack of production and/or loss of the product;
- Costs for the rental of a replacement vehicle during the vehicle standstill period for repairs under warranty;
- Breakage of all types of glass, windows (doors, rear window, windshield).

## 3.2 - Delivery and installation

The dealer has the obligation to perform a set of operations when the vehicle is delivered to the customer. These include a complete check to ensure that the vehicle can immediately operate, an explanation on the safety regulations and a detailed explanation on the instructions contained in the "Use and maintenance" booklet regarding use of vehicle controls, the vehicle maintenance, starting up and stop operations and the use of all the parts. All people who use the vehicle must participate in the training.

For the period of coverage of your vehicle, check the terms in the guarantee certificate.

The guarantee consists in the restoration of the efficiency of parts that are unusable or inefficient due to factory defects through their replacement with original spare parts or through no-charge repair; the costs of transport/travel of the vehicle from the final customer to the dealer/importer and/or to its authorized workshops are excluded, and vice versa.

The warranty is valid only if the vehicle has been used correctly according to the manufacturer's instructions and has not been tampered with, and is immediately terminated if modifications and/or repairs to the vehicle are carried out by personnel not authorized by DIECI.

The warranty also expires in the following cases:

- Failure to comply with, and carry out, the maintenance schedules and mandatory services prescribed by the manufacturer;
- Changes made without the manufacturer's consent;
- Repairs or maintenance carried out with non-original spare parts;
- Incorrect use of the vehicle;
- Carelessness, accidents, late notification of the defect, improper use of the vehicle, damage caused by prolonged use of the vehicle in conditions of declared failure;
- Improper use of equipment or their incorrect assembly;
- Use of lubricants/fuel with specifications other than those prescribed and recommended by the company DIECI.

DIECI is not liable for damage to the vehicle caused by incorrect use or malfunctions of other equipment connected to the vehicle.

The warranty covers only damages and/or malfunctions of the vehicle without the user being able to claim damages for production losses, for presumed or proven damage to equipment connected to the vehicle itself.

## 3.3 - Warranty: duration

The **DIECI s.r.l.** company guarantees its products for 12 months or 1500 hours from the date of delivery to the customer user or to the Dealer/Distributor.

If the vehicle is stored for long periods by the Dealer/Distributor at the time of sale to the customer, the Service Center will reserve the right to verify guarantee activation.

## 3.4 - Warranty: commencement

The guarantee is valid from the date the vehicle is shipped from the factory (sales to Distributors or Dealers). When delivery is handled by the Distributor or Dealer, **DIECI s.r.l.** reserves the right to verify that the guarantee start date corresponds to the shipping or delivery date on the transport document of the product being guaranteed, and/or to the invoice date, and can request original copies of these documents.

## 3.5 - Warranty: activation

The guarantee is automatically valid from the date the vehicle leaves the factory (sale to Distributors or Dealers).

## 3.6 - Warranty procedure

The correct use of the vehicle, associated with regular maintenance, can do much to prevent breakdowns. If, however, malfunctions should occur during the warranty period, the following procedure is recommended:

- Immediately inform the dealer from whom the vehicle was purchased, indicating the model and serial number. The end customer has the obligation to report any flaw or defect regarding the vehicle no later than 8 days from its discovery, under penalty of cancellation of the warranty;
- Give your dealer as much information as possible. So he can know the number of hours of service performed, the type of work you are doing and the symptoms of the problem.

Remember that normal maintenance operations, such as brakes/clutch setting up and adjustment, as well as the supply of materials used for servicing (oil, filters, fuel and antifreeze) are not covered by warranty.

## 3.7 - Intervention campaigns for faulty products

The replacement procedures of parts acknowledged to be faulty will be agreed upon by **DIECI s.r.l.** and its distributors/dealers/authorized workshops.

These intervention campaigns can be followed directly by **DIECI s.r.l.** suppliers, who are responsible for supplying the components to be replaced (interventions authorized by **DIECI s.r.l.**).

The above interventions will be preceded by written communication from **DIECI s.r.l.** to its purchasers.

Only **DIECI s.r.l.** can decide the intervention method (repair, replacement or modification).

## 3.8 - Warranty: intervention request

### 3.8.1 - Guarantee: claim

The claim of the faulty part must be made by the Customer, Dealer, Distributor or Authorized workshop and must be sent directly to **DIECI s.r.l.** Customer Service within 8 days from when it is noted.

The claim must include a clear description of the defect and precise references to the vehicle and equipment (type, model, and serial number). This information can be found on the places indicated in the USE AND MAINTENANCE MANUAL.

### 3.8.2 - Obligation of vehicle downtime

If there is a risk that the defect may jeopardize safety and accident prevention or may cause further damage, the vehicle or the equipment must not be used until it has been repaired and tested.

Any change made on the vehicle or equipment involves a reassessment of conformity with the Machinery Directive 2006/42/EC. This procedure also applies in the case of repairs with non-original parts.

In the event of any dispute, exclusive jurisdiction will be held by the Court of Reggio Emilia - ITALY.

## 3.9 - Non-activation, failure to grant, termination

### 3.9.1 - Warranty: failure to grant

The guarantee is not granted:

- If the defect is not reported as described and within the established time limit.
- If the customer does not comply with **DIECI s.r.l.** request to return the faulty parts replaced during the repairs.
- If the customer has not complied with the obligation to stop using the vehicle after making a claim, limited to damages caused by noncompliance.

### 3.9.2 - Guarantee: termination

The guarantee is terminated:

- If the buyer does not fulfill contractual payment obligations.
- If damage has been caused by carelessness, negligence, or by use of the vehicle for purposes not in compliance with specifications provided in the use and maintenance manual (incorrect

manoeuvres, overloading, use of incorrect fuel, poor maintenance, disregard for warning indicator instruments etc.)

- If the defect is a result of applications, equipment, modifications or repairs not authorized by **DIECI s.r.l.** or carried out using poor quality parts. (For this reason, we recommend always using original spare parts).



## NOTE

Refer to the "MAINTENANCE" paragraph for information regarding recommended routine maintenance.

### 3.10 - Final terms

In none of the cases regarding non-activation of the guarantee, it not being granted or being terminated, the buyer cannot request the cancellation of the contract, or compensation, or an extension of the guarantee.

Any guarantee conditions other than those listed above must be agreed upon in writing and signed by both parties.

Unless agreed upon in writing by both parties; **Dieci s.r.l.** does not pay compensation for any type of claim caused by vehicle downtime, such as:

- Replaced or rented vehicles or equipment
- Labor
- Loss of profit

## 4.1 - General warnings

The instructions for use, maintenance and repair described in this handbook must be followed if the vehicle is to be considered as being operated in accordance with the manufacturer's intended uses.



### DANGER

**THE VEHICLES AND EQUIPMENT MAY NOT BE MODIFIED WITHOUT PERMISSION OF THE MANUFACTURER.**

For your safety and the safety of others, do not change the structure or adjustment of the various components of the vehicle or equipment. The same applies to the deactivation or modification of the safety devices present. Any changes made to the vehicle or equipment, holds DIECI s.r.l. harmless from any liability arising from damage or injury.

Every vehicle or equipment must be used, assisted or repaired only by persons that have received training in advance on the vehicle and on its safety regulations, in addition to being authorized to use the vehicle or equipment itself.



### NOTE

**The user must always observe the general safety regulations as well as those for accident prevention, such as traffic rules if the vehicle is used on public roads (according to the regulations in force in the country of use).**

**DO NOT USE THE VEHICLE OR THE ACCESSORIES IF YOU ARE UNDER THE EFFECT OF ALCOHOL, DRUGS OR IF YOU HAVE TAKEN MEDICINES THAT MAY MAKE YOU DROWSY OR MAY ALTER YOUR REFLEX AND REACTION TIME.**

DIECI s.r.l. is not liable for damage caused by negligent use of this vehicle or the equipment even if said damage is not a result of intentional improper use. Everything possible has been done during the design and construction phases of vehicles and accessories to make your job as safe as possible. Due caution, however, is indispensable and there is no better rule to prevent accidents.



### DANGER

**THE VEHICLES OR EQUIPMENT IN QUESTION ARE NOT SET-UP FOR USE IN ENVIRONMENTS OR SITES EXPOSED TO THE PRESENCE OF EXPLOSIVE GASES, THUS USE IN THESE PLACES IS PROHIBITED.**

To operate in these environments, the Manufacturer must be contacted so that the necessary modifications can be made to the vehicle and/or equipment.



### DANGER

All functions and procedures concerning the operation and mounting of the vehicle or its equipment that are not described in this manual are strictly FORBIDDEN.



### WARNING

Read all of the safety stickers on the vehicle and on the equipment and observe all regulations printed on these stickers before starting up, running or refueling the vehicle or before carrying out maintenance work. Immediately replace damaged, lost or illegible stickers. Clean them when they are covered by mud, concrete or debris.

- Do not use the vehicle or equipment without having first read and understood all parts of this manual, and without having attended an adequate training course.
- Do not use the vehicle or equipment when hands or shoes are wet or dirty with grease or greasy substances.
- Verify that all safety devices function before using the vehicle or the equipment. The operator must always maintain control of the vehicle and equipment state and operation.
- Use the audible warning device or other signals to alert people in the area before starting up the vehicle.
- Inspect control instruments immediately after start up, while the engine is hot and at regular intervals during use, in order to promptly recognize and resolve any malfunctions.
- Do not use the vehicle or equipment if a danger label or a maintenance in progress label is placed inside the cab.

- Do not carry passengers on the vehicle or in the driver's cab or on any other part of the vehicle (including man basket).
- It is prohibited to use the mobile hydraulic parts of the vehicle to lift people except when using the man baskets with relative personal protective equipment for the operator inside.
- Regardless of the user's experience, become familiar with the position and function of all controls and instruments in a work area free from obstacles and persons, before operating the vehicle or the equipment.
- Carry out all the described safety checks before resuming operations.
- While the vehicle is running, always keep light signals on. These serve to warn people that the vehicle is about to move.
- Always keep the safety distance adequate for the type of work and persons or objects in the work area. Always look in the travel direction and maintain good road visibility.
- Adjust movement speed based on the load carried and the type of ground; remain at low speeds to reduce the risk of the vehicle tipping over or losing the load.
- Do not drive with the brake pedal pressed.
- Do not use the vehicle force of impact to carry out tasks. These vehicles are not designed for said use; therefore, such use may cause vehicle overturning, damage, the breakage of components and attachments, or serious personal injury for the user.
- Always operate with the engine hood closed.
- Do not operate with the vehicle protective parts removed.
- When working in a congested area, designate one person to signal and coordinate the work zone.
- Make sure that everyone follows the directions given by the person in charge of signaling.
- Make sure to use signals that conform with the provisions in force in the country of use of the vehicle.
- For additional information with regard to the presence of a person in charge of signaling, consult the "Signals to more vehicles" chapter.
- When working alongside excavations or on the edge of the road or soft ground, keep at a safe distance as the vehicle may overturn.
  - Designate a person on the ground to be in charge of signaling.
  - Remember that after strong rains, the use of explosives or an earthquake, the ground is more fragile.
- When working on the upper part or inside buildings or other structures, verify their capacity and stability before starting operations. The risk of collapse exists and can cause serious injuries or damage.
- Working on a slope may be dangerous. The conditions of the terrain may vary according to climatic conditions (e.g. rain, snow, ice). Therefore, pay careful attention to the conditions of the terrain on which the vehicle is being used; the use of low speeds is recommended.
- Drive slowly on grass, leaves or wet steel slabs. Even when operating on slight slopes the vehicle may slip or lose balance with risk of tipping.
- Tipping conditions of the vehicle can vary depending on the features of the ground, environmental conditions and the type of work. Complying with all the safety instructions contained in this manual reduces risks for the vehicle and the operator in most operating conditions provided herein.
- It is forbidden to use the tractor if there is any risk of tipping that is not covered herein, as this manual contains an incomplete list.

## 4.2 - Safety indications



### ATTENTION

Carefully observe and follow all safety signals on the vehicle and on the equipment and read all safety messages in this manual.

- The safety messages in this chapter illustrate the basic safety procedures of the vehicles and equipment.
- The safety signals must be installed, maintained and replaced when necessary.
- If a safety signal or this manual is damaged or missing, order a replacement from the **DIECI s.r.l.** dealer in the same way in which spare parts are ordered (be sure to communicate the model and serial number of the vehicle when placing the order).
- Learn how to correctly and safely operate the vehicle and the equipment and their relative controls.
- Allow only trained, qualified and authorized personnel to operate the vehicle and installed equipment.
- Keep the vehicle, equipment and accessories in appropriate working conditions.

- Unauthorized modifications to the vehicle, to the equipment or accessories can jeopardize their operation and/or safety and influence their lifespan.
- In case of doubt, contact the manager before proceeding to operate or carry out maintenance work on the vehicle or on the equipment.

### 4.3 - Personal protective equipment

In some cases, when working in particularly uncomfortable environments, adequate clothing or equipment must be worn.

It is mandatory for the operator, before starting to work, to learn from the safety manager or the site manager which are the possible risks of the work and which accident prevention clothes he must wear.



#### ATTENTION

**Always use PPE that is appropriate for the type of work to be performed.**

The Personal Protective Equipment used by the operators can have different characteristics, depending on the type of construction site and risks present in the work place.



#### ATTENTION

**Keep the personal protective equipment in good conditions.**

Accident prevention clothes must always be intact and in good condition. Damaged clothing cannot ensure adequate protection. Do not wear damaged clothing; always replace damaged or torn clothing before operating the vehicle.

#### 4.3.1 - Protective clothing

Icon	Refilling	Description
	ISO7010: M004	Wear protective goggles
	ISO7010: M008	Wear safety shoes
	ISO7010: M009	Wear protective gloves
	ISO7010: M015	Wear high visibility clothing

Icon	Refilling	Description
	ISO7010: M013	Wear a protective mask (for work in dusty environments)
	ISO7010: M017	Use a protective breathing apparatus (for work with dangerous substances)
	ISO7010: M018	Wear a safety harness



#### DANGER

##### Danger of crushing

Pay attention to moving parts to avoid danger of crushing or dragging of the lower and upper limbs. Avoid wearing jewelry or pendants that might be trapped in moving parts. Long hair must be tied back to avoid it being caught in moving parts.

Do not wear loose clothing, chains, belts or other accessories that may be caught in the control levers or in other parts of the vehicle or equipment.

#### 4.3.2 - Protect yourself against noise

Prolonged exposure to loud noise can damage your hearing or may cause hearing loss.

Icon	Reference	Description
	ISO7010: M003	Wear hearing protection



#### ATTENTION

Always wear anti-noise earmuffs or earplugs to protect yourself from excessive and irritating noise.

### 4.3.3 - Protections against objects falling from height

Icon	Reference	Description
	ISO7010: M014	Wear a helmet



## DANGER



### Danger of falling objects

Use of a safety helmet is required if there is a risk of falling objects.

### 4.3.4 - Protect yourself from flying fragments

Icon	Reference	Description
	ISO7010: M013	Wear a face shield



## WARNING

During operation in certain conditions, particles of material may be ejected. In such conditions, it is a good idea to wear protective goggles and clear the area of those people not in possession of such goggles.

## 4.4 - Preparing for accidents

- Always be prepared in the event of a fire or an accident.
- Keep a fire extinguisher and first aid kit at hand. (Not supplied by the manufacturer, "optional accessories").
- Carry out periodic inspections to ensure that the first aid kit contains all necessary items; replenish content if necessary.
- To properly use the extinguisher, carefully read the instructions located on the extinguisher.
- Carry out periodic inspections and maintenance (six monthly) to ensure that the extinguisher is ready for use at any given moment.

- Create priority procedures to deal with fires or accidents.
- Keep emergency telephone numbers (doctors, ambulance, hospital and fire brigade) clearly visible and near the telephone.
- Adequately trained and educated personnel must be present for managing emergencies with adequate theoretical-practical course carried out on site.

Below are some First Aid procedures that can be activated in case of accident following use of the vehicle or equipment object of this use and maintenance manual.

These procedures may be useful in an emergency for the users or other operators present near-by, during use and various life phases of the vehicle or of the equipment (transport, installation, use, maintenance, adjustment, etc.).

### 4.4.1 - First Aider Tasks

1. Activate first aid (emergency call).
2. Evaluate the victim and, if necessary, support vital functions.
3. Stop an external hemorrhage.
4. Protect wounds and burns.
5. Protect the victim against further damages.
6. Do not perform unnecessary or damaging actions, such as giving beverages, moving the victim, reducing dislocations and/or fractures, etc.

### 4.4.2 - Emergency call

Good first aid intervention also depends on the timely arrival of rescuers (emergency medical support) to the place of the emergency.

This is why the first aider in charge of calling the emergency must precisely indicate:

- Address of where the accident or illness took place.
- Number of injured or ill persons.
- The possible cause of the event.
- The state of the vital functions of the injured party, specifying whether the same is conscious or not and breathes normally or not.

At the end of the call it is recommended to:

- Give own details, indicating a telephone number where to be contacted.
- Wait for rescuers in an easily accessible and visible location.



**4.4.3 - Traumas**

**Distortions, dislocations and fractures:**

Immobilize the joints in the position after the trauma, using bandages or splints, supporting the analgesic position of the injured party without attempting dangerous manoeuvres. Apply the cold (with bag of ice or other systems). In case of exposed fracture, cover the wound using a sterile gauze pad, after having pressed at a distance on the specific points the relative hemorrhage.

**Contusions, crushing:**

In case of contusions and/or crushing of ends of the upper and lower limbs (fingers, hand, feet, etc.) it is advised to immediately place the limb underneath running water (cold) and apply ice. Also check for wounds and/or cuts in the hit area and, if necessary, disinfect with the due precautions.

**4.4.4 - Hemorrhages**

It is necessary to press the fingers on the hemorrhage point with sterile gauze pad, lifting the limb and eventually compress upstream of the hemorrhage with tourniquet. Wear protective gloves in case of contact with body fluids.

**Treating superficial wounds:**

Carefully expose and clean the wound, disinfect it with physiological solution, medicate it covering it with sterile gauze pads. Bandage avoiding excessive tightening to allow good circulation.

**Treating deep wounds:**

It is a priority to protect yourself against the risk of infection using gloves and splash shield; pad the hemorrhage by direct pressure or using other pressure points until it stops or the arrival of the ambulance. Call the medical emergency number, informing them that you are padding an arterial hemorrhage.

Treat the wound only after the hemorrhage is under control.



**ATTENTION**

Do not use cotton wool, methylated spirit, antibiotic powder to disinfect the wound.

**4.5 - Preventing fires and accidents**

**4.5.1 - Risks of fires**



**DANGER**



**Danger of fire**

It is forbidden to smoke or use naked flames during use and maintenance operation of the vehicle and equipment.



**Do not operate the vehicle or equipment without the following safety conditions:**



**DANGER**

Fuel, oil and lubricant leaks can trigger fires and cause serious injuries.

- Ensure that there are no flammable liquids leaking.
- To avoid oil or diesel leaks, make sure that there are no loose or missing clamps, no twisted flexible pipes or that rub up against each other.
- Do not bend any pipes under pressure.
- Never install damaged pipes.
- Do not weld piping or pipes containing inflammable liquids.
- Do not use a torch head to cut piping or pipes containing inflammable liquids.



**DANGER**

Short circuits may cause fires.

- Ensure that there are no short circuits.
- Clean and interrupt all electrical connections.
- Check before each work shift that there are no loose, twisted, hardened or damaged electrical cables.



**DANGER**

Fuel, oil, grease, waste, deposits or accumulated dust or other components can cause a fire.

- Remove inflammable materials.
- Prevent fires by inspecting and cleaning the vehicle at every shift, by immediately removing inflammable components.

- Check the ignition switch: in the event of fire, failure to switch off the engine will obstruct the work of the Fire Brigade.
- Do not use naphtha, petrol or inflammable liquids to clean parts of the vehicle. Only use non-flammable detergents.



## DANGER

Safely handle dangerous liquids

- Handle fuel with care, it is easily inflammable. If fuel is ignited, there may be an explosion and/or a fire.
- Do not refuel the vehicle while smoking and in presence of naked flames or sparks.
- Always stop the engine before refueling the vehicle.
- Fill up the tank outside.
- All fuels, most lubricants and some anti-freezes are inflammable.
- Preserve the flammable fluids away from fire hazards.
- Do not burn or drill pressurized containers.
- Do not keep cloths soaked with lubricant; they may cause fires and spontaneous combustions.

### 4.5.2 - Risks of inhaling gas



## DANGER

**Exhaust engine gases are toxic and can cause damages to your health.**

If it is necessary to work in closed ambients, ensure it is sufficiently ventilated and equip the vehicle with special purifiers.

### 4.5.3 - Risks of batteries exploding



## DANGER

**The gas of the batteries may explode.**

- Keep any sparks, open flames or lit cigarettes away from the upper part of the battery.
- Never place a metal object between the clamps to check the battery charge. Use a voltmeter or a densimeter.
- Do not create sparks in the battery connection during recharging phases or starting the engine with auxiliary battery.
- Do not charge the batteries if they are extremely cold, extremely hot or damages as they might explode.
- The ideal temperature for the recharging of the batteries is 16 °C (60,8 °F).
- The electrolyte in the batteries is an extremely corrosive acid.
- Should the battery explode, the electrolyte may be sprayed in the eyes with the possibility of causing blindness.
- Ensure to be wearing protective goggles when carrying out maintenance on the batteries.
- Do not overturn or tilt the battery as acid could come out.

### 4.5.4 - Residual risks



## DANGER

**Damage may be caused by entanglement in moving parts.**

Keep away from moving parts.



## DANGER

**Avoid burns.**

Stay away from hot parts.

#### Jets of hot fluids:

After operation, the engine cooling liquid is hot and under pressure. Contact with hot water or steam may cause serious burns.

Avoid possible injury caused by hot water jets. Do not remove the radiator cap until the engine has cooled down. To open it, unscrew the cap as far as possible. Before removing the cap, release all of the pressure.

#### Hot surfaces and fluids:

The engine, reduction gears and hydraulic system oil heat up during vehicle use. The engine, rigid and flexible pipes and other components heat up.

Wait until all components cool down before beginning maintenance or repair work.



**DANGER**

**Caution with pressurized fluids.**

Fluids such as fuel or hydraulic oil under pressure can penetrate the skin and eyes causing serious injuries.

Avoid these dangers while repairing or carrying out maintenance on the vehicle, discharging the pressures (using the hydraulic levers of the distributors) before disconnecting or repairing pipes and hydraulic parts.

Before restarting the engine, ensure that all fittings have been correctly tightened.

Use a piece of cardboard to check for any leaks; make sure your hands and body are adequately protected against pressurized fluids. Wear a face mask or accident-prevention goggles to protect your eyes.

Should there be an accident, seek medical attention immediately. Any fluids that penetrate the skin must be removed surgically within a few hours to avoid infections.



**DANGER**

**Electrocution**

All maintenance and/or adjustment interventions on powered parts must be carried out only and exclusively by qualified and adequately trained personnel.



**DANGER**

**Risk of slipping.**

During on-site operations, the areas around the equipment may have debris and liquid (oil, water, etc.) that might make the floor slippery. Pay the utmost attention.



**DANGER**

**Risk of falling, tripping.**

Pay the utmost attention when climbing in and out from the vehicle.



**DANGER**

**Crushing of hands and feet.**

The presence of moving parts during operation can cause risks for the ground operators. During vehicle movements, carefully check no unauthorized person is within the required moving area.

**4.5.5 - Contact with dangerous substances**

- Wear the necessary protective clothing.
- Refer to the safety data sheet of the product used and take appropriate precautionary measures when using the product.
- Avoid contact with skin and eyes
  - In case of contact with eyes: rinse them thoroughly with plenty of water for a few minutes keeping the eyelids open and seek medical attention.
  - Should any fluid come into contact with skin, wash the area carefully, remove contaminated clothing, and when skin is dry, apply moisturizing cream. Consult a doctor if necessary.
  - In the event of inhalation, move away from the contaminated area and go to a well-ventilated location. Consult a doctor in the event of respiratory problems.
  - If swallowed: immediately contact a doctor, showing the label or container. Do not induce vomiting to avoid the risk of inhalation via respiratory passageways.

**4.6 - Storing dangerous liquids**



**DANGER**

**Flammable material danger.**

All fuels, most lubricants and some anti-freeze fluids are inflammable.

Handle fuel with care, it is easily inflammable. If fuel is ignited, there may be an explosion and/or a fire.



**WARNING**

All fluids must be kept out of the reach of children and non-qualified persons.

**WARNING**

Do not store together or mix different types of substances.

**DANGER**

**All chemicals are generally very harmful to health.**

Avoid contact with skin and eyes by wearing appropriate protective clothing; do not swallow.

**DANGER**

**It is forbidden to smoke and have open flames**



It is forbidden to smoke or use open flames near fuels.

**Comply with the following precautions to store dangerous liquids:**

- All inflammable fluids must be stored in special containers, and the content must be clearly indicated on each container. Containers must be tightly sealed.
- Store inflammable fluids in well-ventilated locations, far away from heat sources, sparks and open flames.
- Keep containers closed and covered. Other substances (e.g. foodstuffs) must not be present in this location.
- Always fill up the tank when outdoor.
- Be careful of fumes and vapors which may be formed by chemical products. Avoid inhalation.
- Do not breathe in flue gas.
- Ensure that these chemical products do not spill or flow into the ground, sewers or surface waters. If necessary, inform the competent local authorities.
- In the event of a fire, use carbon dioxide, dry chemical powder, foam, sprayed water, sand, earth. Use jets of water to cool down surfaces exposed to the fire.
- Verify that there are no leaks of inflammable liquid (fuel, oil, grease, lubricants in general) in the storage containers.

**NOTE**

Refer to the safety data sheet of the product for additional precautions and warnings that are to be adopted.

## 4.7 - Warnings for safe working

### 4.7.1 - Ensuring the vehicle is clean

- Clean the windows, lights and wing mirrors (if installed).
- Clean dirt and waste away from the engine, articulations and radiator
- Make sure the cab steps and the handle are clean and dry
- Clean all safety stickers and manoeuvring instructions. Replace any stickers that are illegible or missing



#### WARNING

If the vehicle or equipment is not in perfect working order its operation is strictly prohibited.



#### NOTE

For the cleaning procedures, refer to the "CLEANING" chapter.

### 4.7.2 - Checking for damage

- Make sure that there are no damaged or missing parts.
- Make sure that all articulated pins are properly fastened.
- Make sure that there are no signs of possible cracks or flaws or other damage to the windows (if installed).
- Make sure that there are no oil, fuel or cooling liquid leaks underneath the vehicle.
- Make sure that the wheel bolts are properly tightened.



#### WARNING

If the vehicle or equipment is not in perfect working order its operation is strictly prohibited.

### 4.7.3 - Start working with the vehicle

Regardless of their level of driving experience, operators must familiarize themselves with the position and function of all controls and instruments before operating the vehicle.

- Before using the vehicle, check location of personnel.

- While the vehicle is running, always keep light signals on. These serves to warn people that the vehicle is about to move.
- When working in a congested area, have another person present for signaling.
- When manoeuvring the vehicle, pay attention to bulky vehicle parts. There are parts that jut out from the cab.
- Never use controls for purposes different than those for which they were created for; e.g. to climb on or off from the vehicle or hang clothing, etc...
- Only use the vehicle from the driver's position.
- The vehicle may move suddenly if started up without following the correct procedure, thus, creating the risk of personal injury.
- Start up the engine from the driver's seat only.
- Never start the engine by causing a short circuit between the terminals of the starter motor.
- Before starting the engine, make sure all control levers are in a neutral position.

### 4.7.4 - Passengers transportation

Only the operator must be on board the vehicle, passengers are not admitted.

Passengers may obstruct the operator's view, causing an unsafe operation of the vehicle.



#### WARNING

Carrying people on or lifting people up with the vehicle is strictly prohibited unless the vehicle is equipped with an elevation work platform and has a special certificate of conformity regarding the transport of people.



#### WARNING

It is strictly forbidden to transport persons inside the basket while the vehicle is moving even in the presence of elevation work platform and certificate of conformity. It is compulsory to use the man basket only with the parking brake engaged and the outriggers lowered (if present).

### 4.7.5 - Electrical system protection

A burnt fuse must be replaced with another fuse of the same type, amperage and class.

Other types of procedures are not allowed, even if temporary.

Do not connect or remove clamps, fuses, or connectors when the vehicle is switched on or electrically powered.

Any intervention on the electric system must take place with the vehicle not powered electrically. Restore the power supply only after the intervention has been concluded. Remount the lids and protections.

- Use the battery isolation switch to cut off power to the vehicle.
- Cut off power by means of the battery isolation switch even before replacing the vehicle battery.
- In the event that a connector is damaged or is no longer inserted in its housing, replace it immediately in order to avoid short circuits or sparks.

Damaged, pinched or burnt cables must be replaced immediately even if damage is only to the sheathing or outer insulation.



- Never carry out or interrupt any connection on the load circuit, including connections on the battery, with the engine running.
- Never ground (earth) short circuit any charging component.
- Do not use an auxiliary battery with nominal voltage exceeding 12 volt.
- Make sure the polarity is correct when putting in the battery or when using an auxiliary battery when starting the vehicle with cables. Follow the use and maintenance instructions of the manual when starting up the vehicle with cables.



**4.7.6 - Signals to multiple vehicles**

When working requiring more vehicles, give signals normally known to all employed personnel. Designate one person to signal and coordinate the work zone.

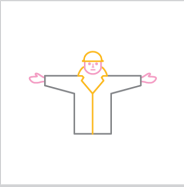
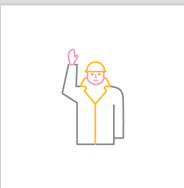
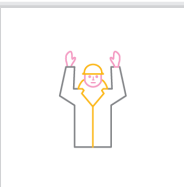
**Before operating make sure that:**

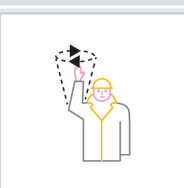
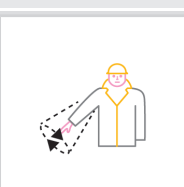
- The user and signaler are aware of the hand signals to be able to interact between them
- That everyone follows the directions given by the person in charge of signaling
- The signaler must be easily identified by the user of the vehicle
- The signaler must wear or hold one or more adequate recognition elements, like: jacket, helmet, sleeves, bracelets, signal paddles
- The recognition elements must be bright colored, preferably one, and reserved exclusively for the signaler.

Movement	Meaning	Description
	Start - Attention - Order taking	The two arms are open horizontally, the palm of the hands forward
	Stop - Interruption - End of motion	The right arm is stretched upwards, with palm of right hand forward
	Danger - Stop - Emergency stop	Both arms stretched upwards
	End of operations	The two hands are joint at height of chest
	Lift	The right arm, stretched upwards, with palm of right hand forward, makes a circle
	Lower	The right arm, stretched downwards, with palm of the hand towards the body, makes a circle

Movement	Meaning	Description
	Vertical distance	The hands, one on top of the other, indicate the distance
	Horizontal distance	The hands, one next to the other, indicate the distance
	Forward	Both arms are folded, the palms of the hands backwards and the forearms make slow movements towards the body
	Move back	Both arms are folded, the palms of the hands forward and the forearms make slow movements away from the body
	To the right compared to operator	The right arm, stretched horizontally, with palm of right hand downwards, slowly makes small movements towards the direction where to move
	To the left compared to operator	The left arm, stretched horizontally, with palm of left hand downwards, slowly makes small movements towards the direction where to move
-	Quick motion	The conventional signals used to indicate movements are quickly made
-	Slow motion	The conventional signals used to indicate movements are made very slowly



**4.7.7 - Working with the danger of falling masses and objects**

When working in areas where there is a risk of falling, bouncing or interference from objects capable of hitting the operator or entering the cab:

- Always close the windows.
- Always ensure that other operators near-by are at a safe distance and cannot be hit by bouncing or falling objects.
- Never carry out work operations under an overhang; this could give way and fall onto the vehicle.
- When working from the cab:
  - Mount suitable safety panels to protect the operator.
  - Always close the windows.
  - Pay careful attention to crumbling walls, landslides, falling material or objects from the installed equipment, that may hit the cab, the protective structure or windows, causing damages to the vehicle and to the operator.
  - Do not excessively weigh down or fill the installed equipment or transport loads that may come out or fall on the ground.
- When working from the man basket:
  - Install optionals on the basket such as the roof to provide additional protection to the operators.



**WARNING**

**Danger of falling objects**

Use of a safety helmet is required if there is a risk of falling objects.

**4.7.8 - Working near electrical lines**

Before working near overhead electrical lines, check that the safety distance is sufficient, in compliance with the current Standard in the country of use. In any case, never work near electrical lines at distances shorter than those in the table below or at the minimum distances indicated by the Standards in force in the country of use of the vehicle and of the equipment.

Damp ground may increase the risk of electrocution.

Operating or parking the vehicle too close to electrical cables leads to increased risk of being struck by lightning or being seriously injured.

Designate someone on the ground to signal when too close to electrical cables.

Do not allow anyone near the vehicle when working in the vicinity of electrical cables. To prepare for any possible emergency situation, wear rubber shoes and gloves, cover the seat with a rubber piece of fabric and take care not to touch the chassis with any unprotected body parts.



**DANGER**

**High voltage danger**

Should the vehicle or the equipment installed on it collide with an electrical cable, the user, to avoid electrocution, must remain inside the driver's cab until certain that the electrical power supply has been properly disconnected.



**DANGER**

**High voltage danger**

If operating close to overhead electrical lines, check the safety distance in the table below, reported in the Italian Legislative Decree 81/08 Enclosure IX. The table is valid if the vehicle is used on Italian territory. However, refer to the Standards in force in the country of use of the vehicle and equipment.

Un (kV)	Distance
≤ 1	3 m (9.84 ft)
1 < Un ≤ 30	3.5 m (11.48 ft)
30 < Un ≤ 132	5 m (16.40 ft)
> 132	7 m (22.96 ft)

**4.7.9 - Working under the snow**

Snow can hide obstacles and objects, and cover holes, dug-out areas and ditches, therefore, proceed with caution.



**WARNING**

Operation of the vehicle if the quantity of snow does not allow for clear distinction of obstacles and possible dangers along the path, is strictly prohibited.

- Take care when clearing snow and do not venture off the main road; that which is hidden at the sides of the road may cause vehicle overturning or damage to various components.
- Surfaces covered by snow or ice are extremely dangerous. Operate with caution, reducing vehicle speed as much as possible and engaging levers slowly.

- Operate with caution. If the vehicle should sink into the snow, it may overturn or remain buried. Do not venture from the road and avoid remaining entrapped or buried under heaps of snow.
- Extra care should be taken, when working on icy terrain. The ice will melt as the temperature rises and the ground will become slippery.
- Use caution in the presence of electrical cables, ditches, or freshly excavated or worked ground.
- Make sure not to cause risk to others in the area when backing up the vehicle.
- Always check the space around the vehicle before carrying out any manoeuvres

- Spaces with dangerous or explosive atmospheres.
- Protected environments such as refineries.



### ATTENTION

**The vehicle must be appropriately modified and certified to work in environments with an explosive atmosphere.**

The vehicle can only be used in a tunnel if it has been declared suitable for these environments.



### NOTE

If working the vehicle at temperatures below -10°C (14°F), empty and refill the tank using lubricants, fuel or cooling liquids suitable for such temperatures.



### NOTE

There are accessories that can be used to facilitate working with ice or snow, contact your dealer or agent.

## 4.7.10 - Working with scarce lighting



### ATTENTION

**The standard illumination of the vehicle is not suitable in working conditions with poor visibility or for use at night.**

The vehicle can only be used with sufficient lighting in the work area.



### NOTE

There are several ways to improve visibility in conditions of poor lighting. Contact your local **DIECI s.r.l.** dealer.

## 4.7.11 - Working in closed areas or dangerous atmospheres

**It is FORBIDDEN to use the vehicle in:**

- Suitably ventilated closed spaces, that are nevertheless not compatible for the use of equipment with running endothermic engines.

### 4.7.12 - Reduce vibrations

Consider the following recommendations to reduce the vibration exposure of the operator:

- Always use the appropriate equipment for the job to be carried out.
- The driver's seat must be properly adjusted to suit the operator needs. Inspect and if required repair the suspensions and the regulation mechanisms of the seat.
- Make sure that the vehicle is kept efficient, perform vehicle maintenance as prescribed in this manual.
- Steer, accelerate, brake, shift gears, move the tool in a non-abrupt way.
- During transfers adjust the speed of the vehicle to minimize the level of vibrations. Reduce speed to avoid the risk of jolting. Transport the vehicle in the event of significant distance between job sites.
- Maintain the workplace in good condition, remove stones and obstacles, fill depressions or holes etc.
- To avoid back pain problems, use the vehicle only in good health.
- Take breaks so as to reduce the time of sitting in the same posture.
- Do not exit the cab or go out of the vehicle with a jerk.
- Avoid to lift and move loads repeatedly.
- Further recommendations to reduce vibration when working with man basket:
  - Use the controls smoothly.
  - Do not make any sudden movements on the man basket.
  - The vibrations generated by the vehicle are not a source of risk when using the basket.

### 4.8 - Working in windy conditions

Wind speed variation can cause a number of problems including the loss of vehicle stability, load oscillation, and a decrease in visibility due to dust, leaves, etc.

Adverse factors to vehicle use are:

- Location of the work site, the aerodynamic effect of buildings, trees and other structures influence wind speed.
- The height of the extended boom: the higher the boom is raised vertically, the higher wind speed becomes.

- Load bulk area: the more space the load occupies, the more the wind force is felt.

#### Strong wind

**DIECI** telehandlers can be used up to a wind speed of 45 Km/h, equal to 12.5 m/s (No.6 on the Beaufort scale) measured on the ground.

At 10°C temperature, wind with a speed of 32 Km/h it seems that exposed parts of the body have a temperature of 0°C. The higher you climb the faster the wind speed and the more the sensation of pressure drop increases.



#### WARNING

#### Strong wind danger

In the presence of strong winds (no.5 Beaufort scale) never lift loads with surfaces exceeding 1 m<sup>2</sup>.

Below you can find the graph of the Beaufort scale for an indication of the wind speed with which you are working and when to suspend operations, if wind speed should exceed determined values.

Beaufort Wind Scale			
No.	Definition	Indicators	Speed (m/s)
0	Calm	Smoke rises vertically	0 - 0,2
1	Light air	Smoke drift wind direction	0.3 - 1,5
2	Light breeze	Wind felt on exposed skin. Leaves rustle; vanes begin to move	1.6 - 3
3	Gentle breeze	Leaves and small twigs constantly moving; light flags extended	3 - 5
4	Moderate breeze	Dust and loose paper raised. Small branches begin to move	5 - 8
5	Fresh breeze	Small trees in leaf begin to sway; glassy water, small waves form	8 - 11
6	Strong breeze	Large branches in motion. Whistling heard in electrical cables. Umbrella use becomes difficult	11 - 14
7	Strong wind	Whole trees in motion. Effort needed to walk against the wind	14 - 17
8	Fresh gale	Some twigs broken from trees. Cars veer on road	17 - 21
9	Strong gale	Slight damage to buildings (falling chimneys and tiles)	21 - 24

## 4.9 - Assessing the consistency of the work ground

The ground on which the vehicle can be positioned must be able to support the vehicle and its maximum bearing capacity.



### DANGER

#### Danger of tipping

The sinking of the vehicle base support may cause the vehicle tilting.



### ATTENTION

**Contact a qualified technician to assess the consistency of the ground according to the regulations in the country of use of the vehicle.**

Request in any case the advice of a qualified technician to know whether in the workplace, there are hidden cavities (pipes, wells, old tanks, basements, manure, etc...).



### NOTE

Refer to the "Technical data" chapter in the manual of the vehicle, to know the maximum load that each wheel or outrigger (if any) can apply on the ground while using the vehicle.



### DANGER

**When loading or unloading goods, the vehicle must always be in a horizontal position.**

Avoid loading or unloading operations if the vehicle is slanted.

## 4.10 - Moving safely



### NOTE

The following operations are standard for any type of installed equipment; however, refer to any warnings present in the equipment manual.



### WARNING

In the event of scarce visibility, have a person operate on the ground for signaling.



### WARNING

Do not lift or lower the loads when the vehicle is in motion.

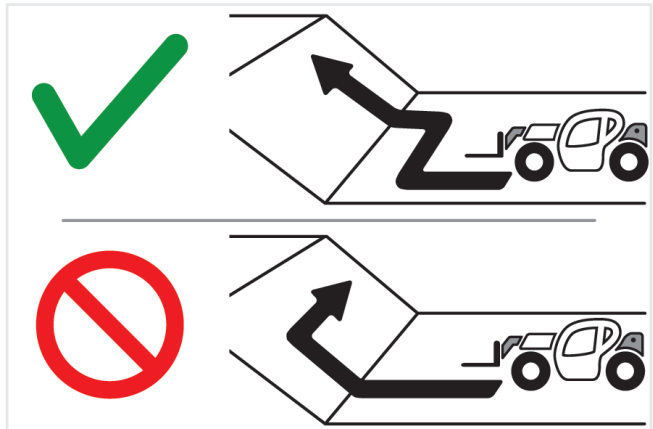

Figure: 150533-1

Operating on sloped terrain can cause overturning or sliding. Move forward and brake gradually and take all necessary cautions.

Always move in a straight line to go up or down a slope. Moving transversally or along the slope is extremely dangerous (fig. 150533-1).

Always use the parking brake when setting down or lifting a load on a slope.



### WARNING

**Check the vehicle is leveled before using the boom on sloped ground.**

Do not stop and leave the vehicle parked on a slope exceeding 15%, even with the parking brake engaged.

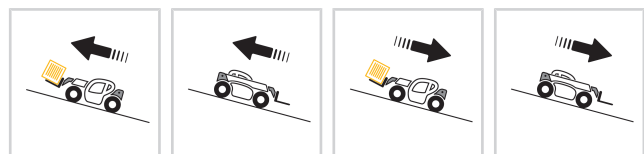

150534-1

150534-2

150534-3

150534-4

- In the event of having to travel uphill while transporting a load, operate always maintaining the load towards the top of the uphill (fig. 150534-1).
- When having to drive uphill without a load, operate with the vehicle facing downhill (fig. 150434-2).
- In the event of having to travel downhill while transporting a load, operate always maintaining the load towards the top of the uphill (fig. 150434-3).

- When having to drive downhill without a load, operate with the vehicle facing downhill (fig. 150534-4).

## 4.11 - General warnings for moving the load

Always adhere to safety regulations; always transport balanced, properly arranged load to prevent the risk of tipping.



### ATTENTION

**It is strictly prohibited to work without the respective load charts for the equipment and the vehicle.**

When using this vehicle, carefully follow the load charts of the vehicle with the equipment mounted at that moment.

Do not attempt to carry out operations which exceed the capacity of the assembled equipment or of the vehicle.

Do not modify the structure and vehicle stability in any way by trying to add counterweights, whichever artifice is used.

Always ensure the pallet, the boxes and other supports for the load are in good conditions and adequate to the load to be lifted; the sudden collapse of a rack of material is often caused by a faulty pallet.

**Do not move the load with boom lifted or extended.**

- Handle the vehicle with the boom raised only in exceptional circumstances. In these circumstances, operate with due prudence, reduce speed as much as possible and brake delicately. Make sure that visibility is always sufficient and ask an operator on the ground to guide you for the operations.
- Reduce the speed as much as possible and brake gently during handling operations.



### WARNING

Do not handle loads while the vehicle is moving.

Avoid passing over unstable objects. Remove dangerous, unstable objects instead of passing over or around them. Also avoid holes and ditches that might make the load jolt.

Before turning, slow down as much as possible, and monitor the load.

Do not change direction abruptly or at high speed.

Remember that hydraulic steering is very sensitive to steering wheel movements; steer gradually and avoid sudden movements.

Slow down before turning.

Pay attention to the side space, in particular if transporting wide loads. If possible, keep to the center of the passage to avoid equipment or personnel from obstructing your path.



### WARNING

Handle loads with care, at low speed and without sudden or jolting movements, above all if they are carried at great heights.

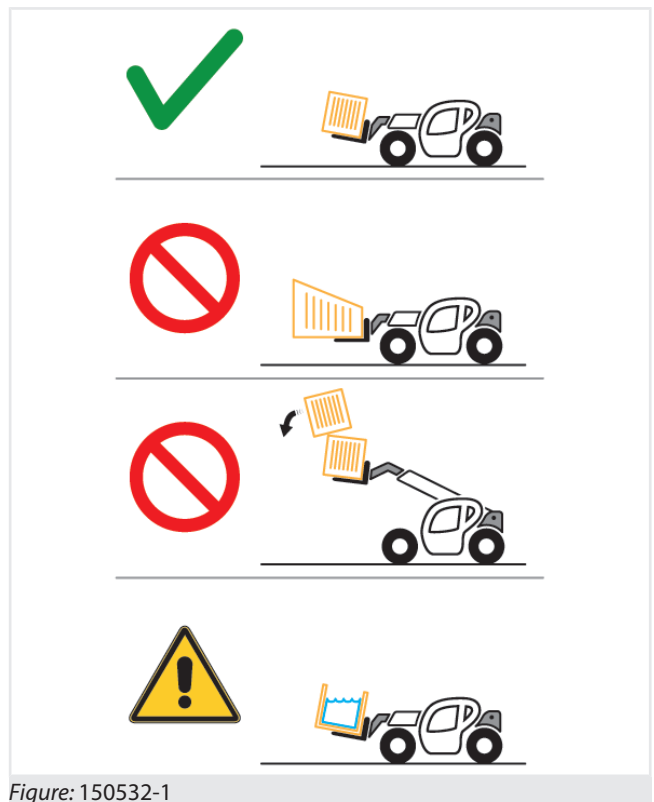

Figure: 150532-1

- Always ensure good visibility in the work area, including direct vision and visibility using wing mirrors in order to check for the presence of people, animals, obstacles, holes and changes in slope etc.
- Decrease the working speed of the vehicle in case of rain, fog, snow or in any case where visibility is reduced.
- If visibility on the right side is limited during boom operation, before lifting the load, ensure that the work area is clear and make note of the position of any possible obstacles and irregularities in the terrain.

- Always make sure there is good visibility (clean windows, clean mirrors, clean lights that work properly, etc.).
- Maintain control of the vehicle and its speed in all circumstances. The speed of the loaded vehicle must never exceed 10.0 Km/h (6.21 mph). If the load exceeds the maximum allowed load by 50%, vehicle speed must be reduced to 5.0 Km/h (3.11 mph).
- Do not drive in reverse for long distances.
- Brake gradually; avoid braking abruptly.
- Always maintain the safe distance from other vehicles in order to have sufficient space to brake in every condition.



### ATTENTION

Before lifting loads, operators must be familiar with the weight of the load and its center of gravity.

- Transport the load as close as possible to the ground. Keep the load low, at a height from the ground of 300 mm. Never move with the load lifted more than necessary.
- The load diagrams are valid for centers of gravity of standard loads. For particular loads, contact your dealer.
- Pay the utmost attention during transporting of loads with variable center of gravity (e.g. Liquids). Operate with caution in order to limit such variations and to prevent the risk of vehicle overturning.
- Always ensure the moved load is correctly balanced and cannot fall on the ground. The loss of the load or part of it can entail a danger of damage to things and persons
- Pay the utmost attention to objects that may fall. Ensure there are no unstable objects on the upper part of the load.



### WARNING

**Never lift a load when the vehicle is on a sloped surface. When on a sloped surface, pay attention to the conditions of the ground. When working with the vehicle on a sloped surface with the load high, a jolt or a hole is sufficient to make the vehicle overturn.**

Do not move the boom if the vehicle is located on terrain with a slope greater than 2° (3.5%).

## 4.12 - Use of cables, ropes and slings



### DANGER

**It is strictly forbidden to lift or move load fastening ropes or chains only to the vehicle's attachment holding plate, to forks or to any other equipment not designed for this purpose.**

Various equipment set-up for lifting, provided with suitable hooks for the use of cables, chains and straps are available. For further information contact your Dieci dealer.

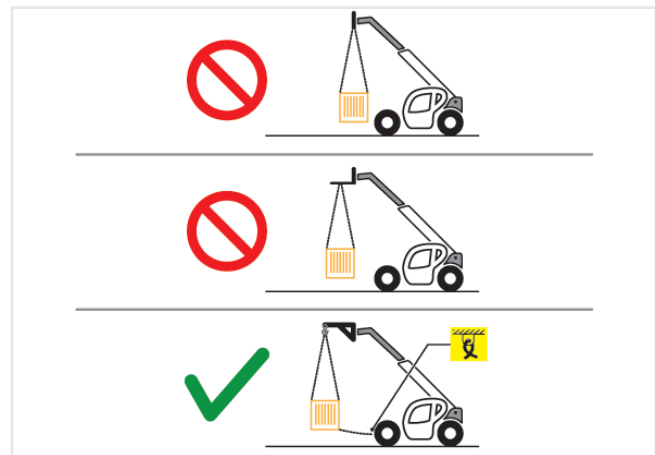

Figure: 150535-1

To keep the suspended load from swaying while being handled, the load can be fixed to the anchoring eyebolts of the vehicle while being transported.

## 4.13 - Road travel

### 4.13.1 - Road travel warnings



### ATTENTION

Before starting the road travel make sure to observe the relevant laws and regulations in the country of use.

The road travel requirements are shown on the Vehicle Registration Document.

Low beam lights must be on even during the day and in streets where there is no obligation to use visual and lighting signaling devices.

Ensure correct operation and cleaning of headlights, direction lights and windscreen wipers.



**WARNING**

**Check the correct position of the wing mirrors.**

The objects seen through the wing mirror are closer than they appear.

When driving on the road and/or on a slope it is necessary to be very careful to the engine rpm. A high number of rpm can lead to mechanical failures. Keep under control the engine rpm and speed.

Pay particular attention to loading docks, trenches, scaffolding and land recently excavated or filled.



**ATTENTION**

**When going downhill, on icy or wet surfaces, use the slow gear (turtle).**

**4.13.2 - Road travel instructions**

- Level the vehicle so that the wheel axles are aligned with the chassis (if present).
- Ensure that all outriggers have been perfectly retracted and raised (if present).
- Close the telescopic arm (boom) completely.
- Lower the telescopic boom completely and then raise it slightly to about 20-30 cm from the ground.
- Check the correct operation of the lights before moving on roads. Check that the rotating light for slow vehicle signaling is installed and running; keep the rotating light in operation both at day and at night.
- Perform the wheels alignment, so that they are perfectly aligned with the vehicle chassis.
- **It is mandatory** to arrange the steering as reported in the Vehicle Registration Document and lock the selector lever with the dedicated device.
- Make sure that the amount of fuel is sufficient.
- Assemble all the accessories required for road circulation depending on the country in which the vehicle is operating.
- Install an overhanging load signal panel on the boom head before the entering onto the road.
- Always evaluate the road to be traveled, taking account of suspended structures (e.g. bridges, underpasses, etc.) that could be damaged by the vehicle.

- In some countries it is mandatory to place wheel chocks under the tires when the vehicle is stopped.
- Make sure that your vehicle is in compliance with local legislation in reference to the presence of the license plate when traveling on the road both at day and at night.



**WARNING**

Road transfer with equipment assembled to the fork holding plate is not allowed except those accepted by the legal authority of the country where the vehicle operates.



**WARNING**

**It is not allowed to travel on public roads with loaded vehicle.**

Comply with the maximum permissible mass written on the vehicle registration document.

**4.14 - Momentary stop**



**ATTENTION**

If it is necessary to leave the driving position, follow the steps in the "Parking the vehicle" paragraph.



**WARNING**

Never move away from the vehicle, leaving the engine running or the ignition key on the vehicle.



**WARNING**

Do not stop and leave the vehicle parked on a slope exceeding 15%, even with the parking brake engaged.

- Gradually release the accelerator pedal.
- Stop the vehicle on even ground.
- Engage the parking brake
- Bring the movement selection lever to "N".
- During the running-in of the vehicle (50 h), do not keep the diesel engine at minimum revs for too long.

## 4.15 - Parking the vehicle

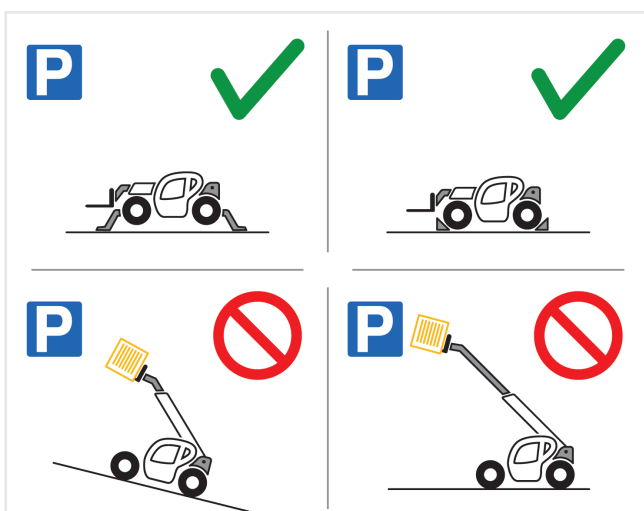

Figure: 150536-1

Never leave in any case the vehicle parked with a raised load.

- Always park on flat, firm and level ground, where there is no risk of falling rocks, landslides or flooding.
- Lower outriggers to the ground (if present).
- Retract the boom completely and lower it to the ground.
- Engage the parking brake
- Bring the movement selection lever to "N".
- Run the engine at idle speed for some seconds before turning it off, in order to allow the engine cooling.
- Turn the ignition key to the engine stop position.
- Remove the key from the ignition switch.
- Lock the hydraulic controls with the special devices (if present).
- Close the windows and lock them with the handles.
- Close the cab door by key.
- Place wedges under the wheels.
- Make sure that the vehicle is parked so as not to impede its movement and at least 5 meters away from the railroad tracks.



### WARNING

Do not stop and leave the vehicle parked on a slope exceeding 15%, even with the parking brake engaged.

## 4.16 - Starting and stopping the vehicle

### 4.16.1 - General warnings regarding starting up the vehicle



#### WARNING

Do not use the vehicle without having first read and understood all parts of this manual, and without having attended an adequate training course.

- Before starting the engine, make sure all control levers are in a neutral position, the parking brake is engaged, the engine hood is closed and that there is nobody in the area surrounding the vehicle.
- The vehicle can only be started up or maneuvered when the operator is seated in the driver's seat, with the seat belt fastened and adjusted.
- The vehicle may move suddenly if started up without following the correct procedure, thus, creating the risk of damage.
- Never start the engine by causing a short circuit between the terminals of the starter motor.
- Never start-up the engine by pushing or pulling the vehicle. This could seriously harm people or cause serious damage to the vehicle.
- Be careful when using auxiliary batteries as the gas contained in these may explode, causing serious damage. Follow the instructions provided in the "Emergency procedures" chapter, "Start-up using auxiliary batteries" paragraph to start the engine using auxiliary batteries. An incorrect procedure can cause serious damage to the electrical/electronic system, the vehicle could move suddenly, the battery could explode and damage could be caused to objects and/or people.
- Do not start the engine or touch the levers of the vehicle if a danger sticker or a maintenance in progress sign is placed inside the cab.

### 4.16.2 - Inspections prior to starting-up

#### 4.16.2.1 - Inspecting the vehicle

Carefully inspect your vehicle every day or before every shift.



Carry out the following inspections and operating checks:

- Parking brake efficiency
- Intact condition of the tires
- Type of tire suitable for the type of work ground
- Engine oil level (check and top-up, if necessary)
- Hydraulic oil level (check and top-up, if necessary)
- Air filter clogging indicator (check and clean, if necessary)
- Tire inflation and pressure (check)
- Fuel level (check)
- Signaling and warning devices (check)
- Steering efficiency
- Service brake efficiency
- Tightness of all nuts and bolts
- Lighting
- Direction indicators
- Emergency Lights
- Switches
- Indicator lights
- Windscreen wipers
- Reverse buzzer/alarm
- Position and condition of wing mirrors

- Examine the conformation and condition of the terrain of the work area before beginning to operate.
- Keep the vehicle well away from the edge of the excavation and the side of the road.
- When working on a slope or near the roadside, have another person present for signaling.
- Pay utmost attention when working on icy ground. The ice will melt as the temperature rises and the ground will become slippery.
- Check for any overhead electrical lines or underground pipes.
- Do not work in places at risk of landslides or falling rocks.
- Take due precautions to prevent any unauthorized persons from entering the working area.
- When moving through or operating in shallow water or soft ground, verify the shape and the conditions of the land, the water depth and flow rate before beginning the operation.



**DANGER**

**Immediately stop using the vehicle in case of malfunctions or if it does not comply with safety standards.**

Contact an authorized *Dieci s.r.l.* workshop if the vehicle shows malfunctions. Refer to the "Maintenance" chapter for information regarding routine maintenance.



**NOTE**

A thorough inspection is required if the vehicle is not used for a prolonged period of time. A detailed description of the operations is provided in the "Vehicle storage" chapter

**4.16.3 - Starting-up the engine**

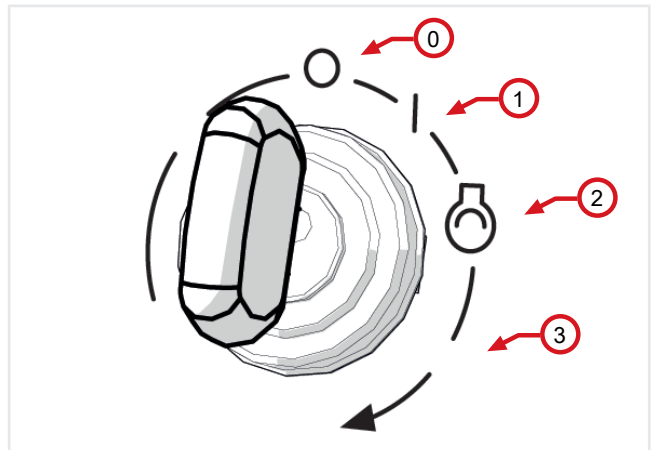

Figure: 150538-1

**Proceed as follows to start-up the engine of the vehicle:**

1. Press the parking brake switch.
2. Bring the movement selection lever to neutral.
3. Remain seated in the driver's seat.
4. Turn the ignition key (fig. 150538-1) clockwise to position "1".



**WARNING**

**Wait 1 second, then turn the key in position "2" for a correct operation of the control unit.**

**4.16.2.2 - Inspecting the work area**

- Examine the work area when working at the edge of an excavation or on soft ground as the vehicle could overturn.

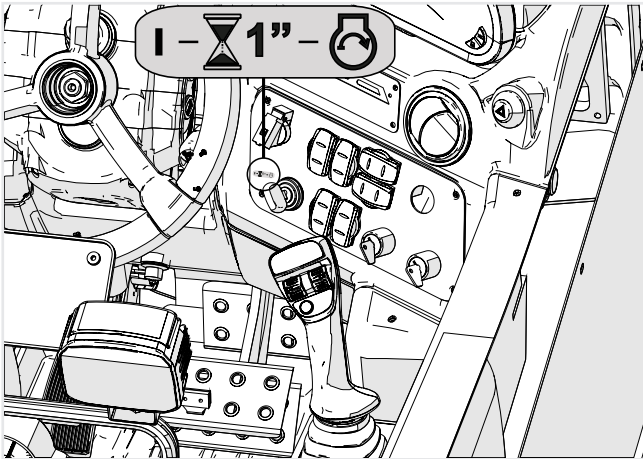

With the key in this position:

- The control panel and instrument panel will be powered
- A buzzer will sound, indicating that the key has been inserted. This buzzer also serves to warn any persons in the surrounding area that the vehicle has been started up.
- A check-up of the instrumentation will be performed with all the indicators lighting up for about 5 seconds. Only the following lights must remain switched on at the end of the check-up:
  - Engine oil pressure warning light
  - Battery charge indicator light
  - General alarm warning light
  - Intermittent buzzer
  - Other indicators of activated functions (e.g.: Parking brake, gears engaged, etc.)

**WARNING! If other indicators remain on signaling malfunctions or if one of the previous conditions does not occur, do NOT start-up the engine and refer to the "Maintenance" chapter or contact the Dieci service center.**

- Turn the ignition key (fig. 150538-1) to position "3" to start-up the engine. Release the starter within 5 seconds.
- Release the key once the engine has started. The indicators related to the engine oil pressure and battery charge must go off once the engine is started up.
- If the engine does not start within 5 seconds, try again at regular 15 second intervals to prevent overloading the starter motor.

#### 4.16.4 - Warm-up after starting-up

During the first few minutes of use, keep the speed slow in order to warm up the engine and hydraulic oil.



#### WARNING

Serious damage can be caused to the engine and the hydraulic system if the engine reaches high rpm before the operating oil temperature and pressure levels are reached.

Let the engine run at 1100 - 1300 rpm for about 5 minutes so as to bring the engine oil to the operating temperature, particularly, with outdoor temperatures below 0 °C.

#### 4.16.5 - Start-up at low environmental temperatures

Consider the following warnings before starting-up at low environmental temperatures and with a cold engine:

- In order to prevent discharging the battery, do not prolong each attempt to start-up by more than 15 seconds; however, if the engine does not seem to be starting-up, extend the time to a maximum of 30 seconds.
- Wait at least one minute before trying to start-up again.
- It is recommended to not exceed six start-up attempts so as not to discharge the battery excessively.



#### NOTE

It is recommended to use anti-freeze diesel at environmental temperatures lower than 0°C, so as to make sure the engine is optimally supplied, without reducing performance.

#### 4.16.6 - Causes of failed start-ups

Check the following if the engine does not start-up:

- The parking brake switch is pressed.
- The gear selection lever is in the neutral position.
- No emergency stop buttons are pressed.

After checking all the previous conditions, remove the cause of failure to start and try the starting procedure again.



#### NOTE

If the problem persists, contact a *Dieci* after-sales center.

#### 4.16.7 - Turn off the vehicle

It is recommended to perform the following before switching the engine off:

1. Bring all the control levers to the idle position.
2. Bring the engine to low speed for a few seconds.
3. Turn the ignition key to position "0".

**NOTE**

**The images used to describe components and controls refer to a complete vehicle with all accessories; these may vary depending on the attachments and on the configuration chosen.**

Refer to the "Definitions" section to understand references such as: Right side, Left side, Front and Back used in the manual.

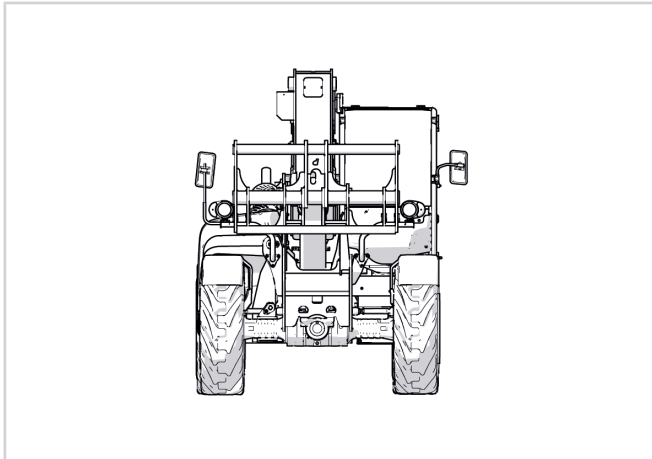
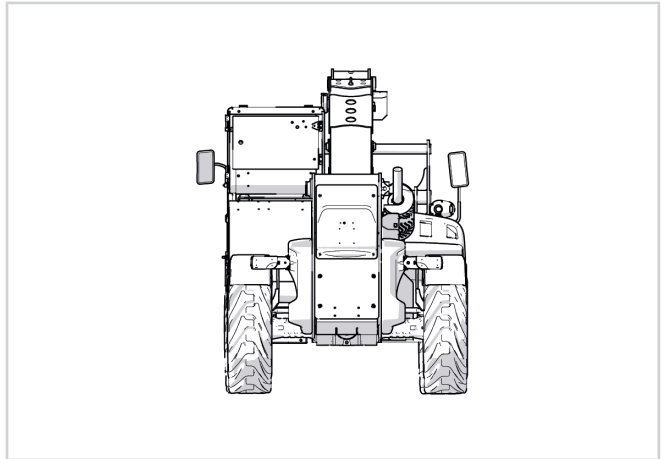
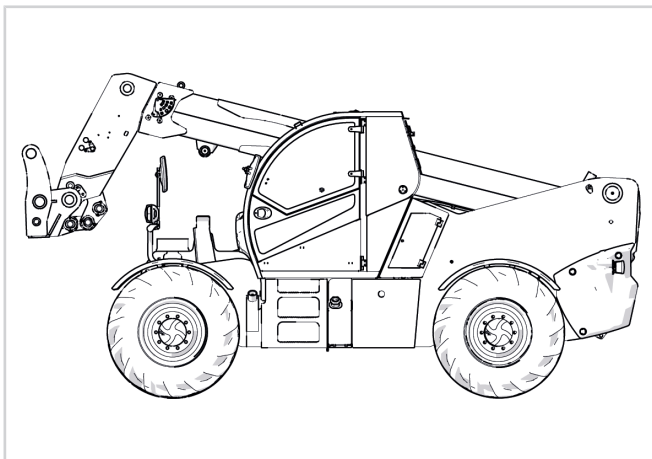
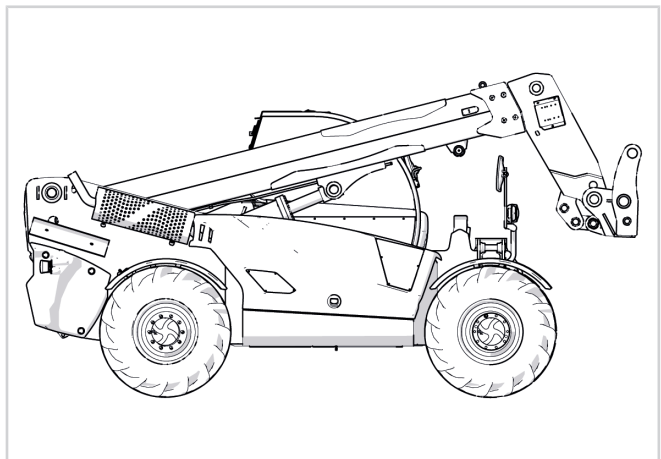
*150641-1: Front view**150641-2: Rear view**150641-3: Left view**150641-4: Right view*

**5.1 - Left side components description**

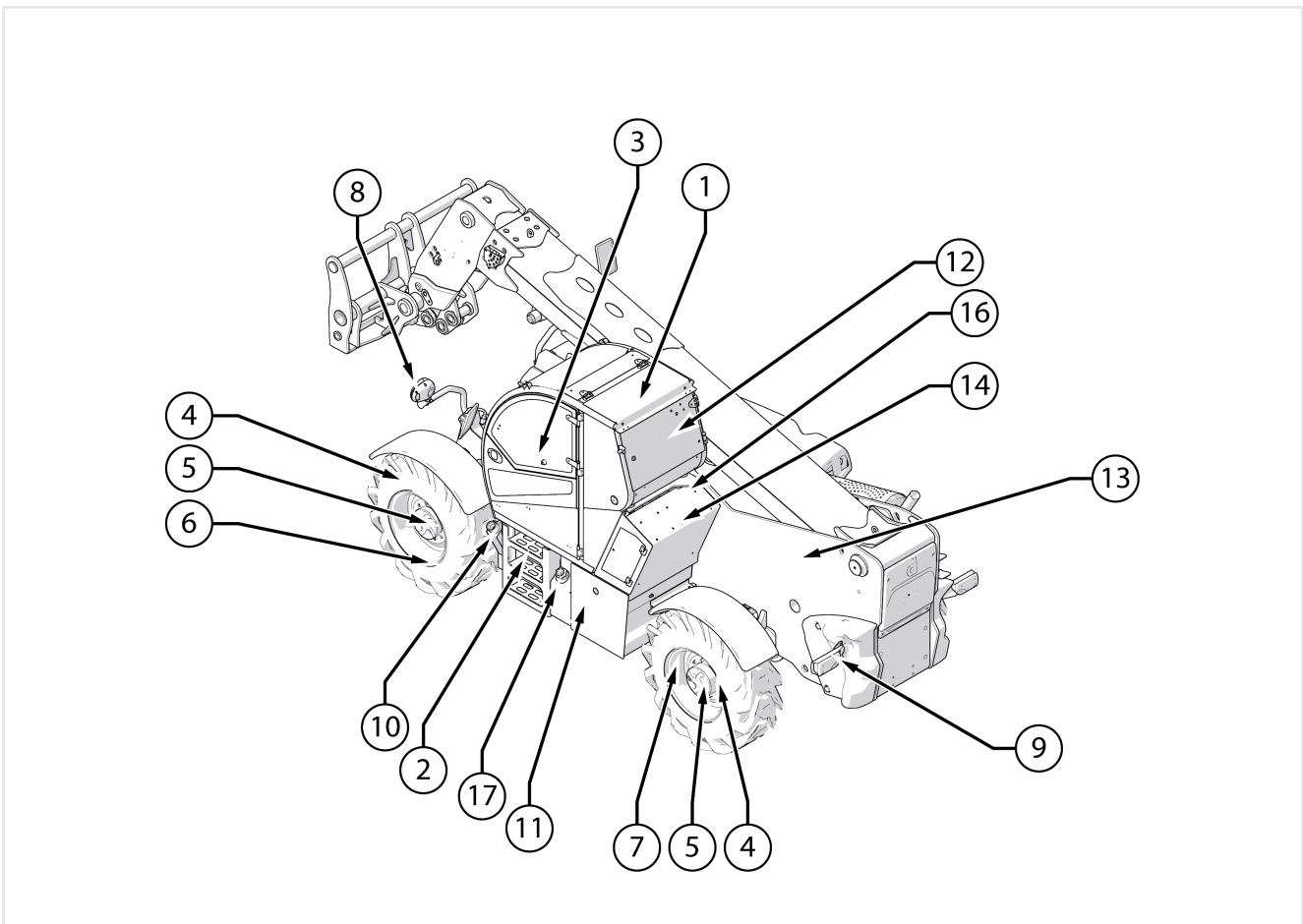

Figure: 150970-1: Left side vehicle description

1 Cab	2 Steps for climbing on
3 Door	4 Wheel
5 Epicycloidal reduction gear	6 Front axle
7 Rear axle	8 Left headlight
9 Left tail light	10 Fuel tank
11 Oil tank	12 Rear emergency exit
13 Radio remote control receiver (optional)	14 Battery
15 Battery compartment	16 Air conditioning (optional)
17 AdBlue tank	

## 5.2 - Right side components description

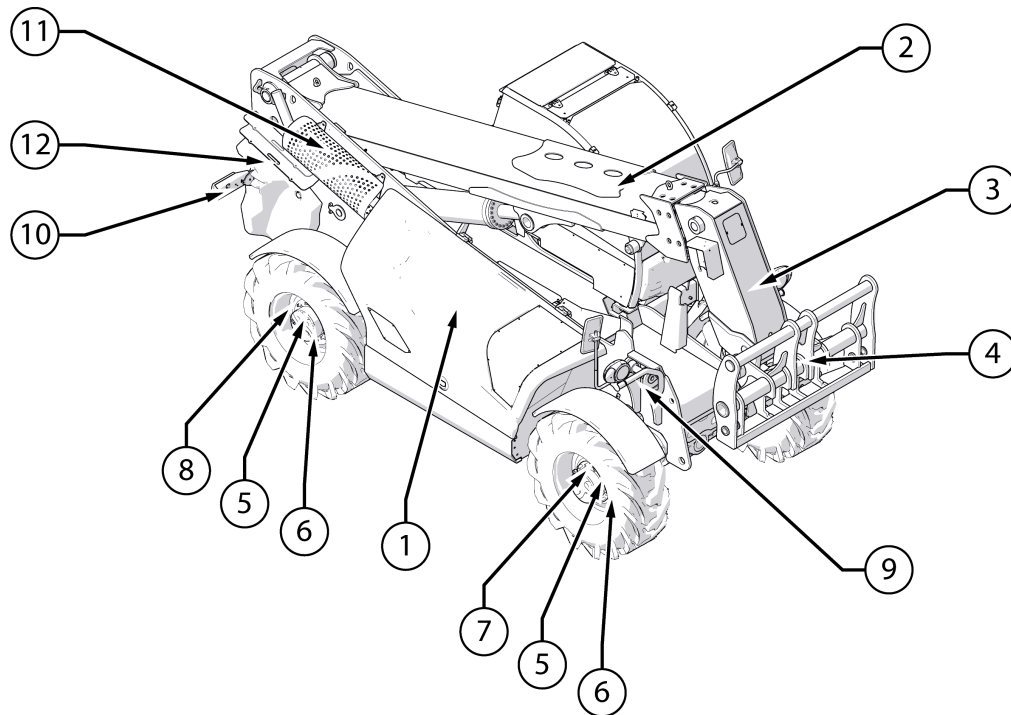

Figure: 150971-1: Right side vehicle description

1 Engine hood	2 Telescopic boom
3 Boom head	4 Attachment holding plate
5 Wheel	6 Epicycloidal reduction gear
7 Front axle	8 Rear axle
9 Right front headlight	10 Right rear headlight
11 Muffler	12 Boom support rod

**5.3 - Engine components description**

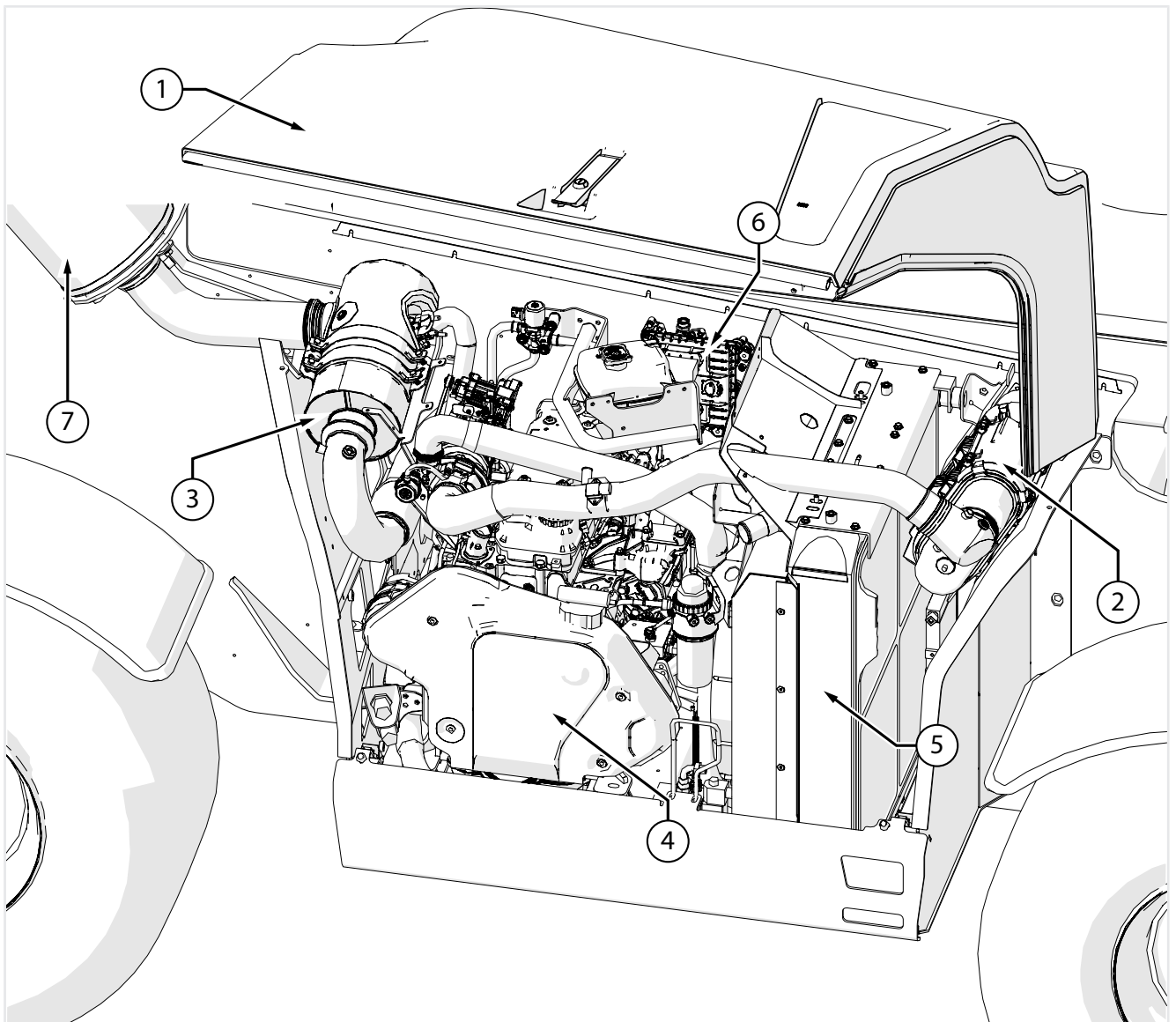

Figure: Engine view

1 Engine hood	2 Air filter
3 DOC	4 Engine
5 Radiator	6 Engine control unit
7 SCR	

## 5.4 - Cab components description

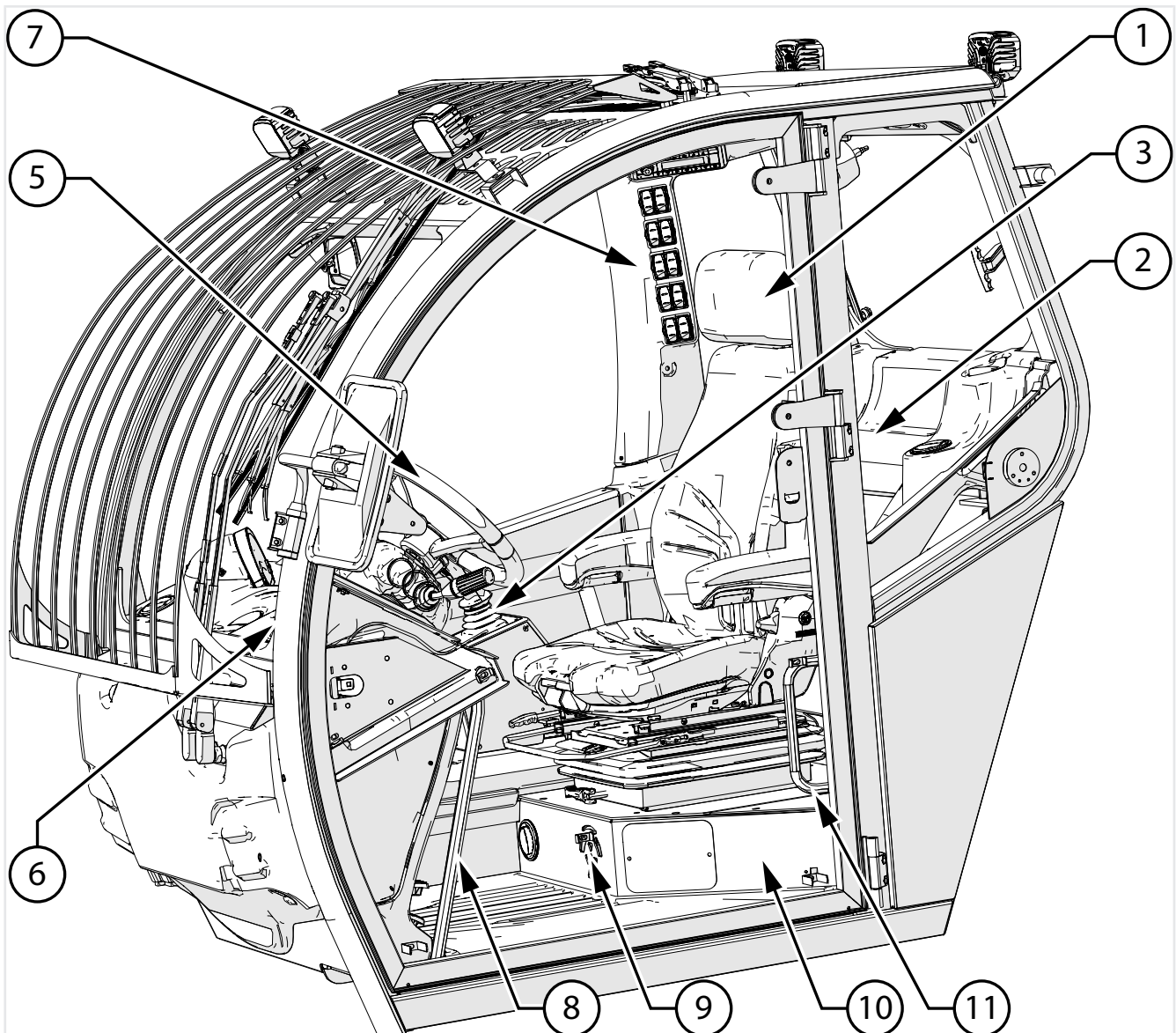

Figure: 161044-1: Cab description

1 Seat	2 Storage compartment
3 Right joystick	4 Left joystick
5 Steering wheel	6 Central instrument panel
7 High instrument panel	8 Handle for climbing on
9 Cab ventilation adjustment	10 Cab air filter
11 Handle for climbing on	



## 6.1 - List of safety devices

Safety devices	Additional information	
Safety devices	7.1	Cab
	7.1.1	ROPS - FOPS Cab
	7.1.16	Emergency Lights
	7.1.17.1	Deadman seat sensor
	7.1.17.3	Seat belts
	7.1.18	Emergency stop
	7.1.20	Emergency exit: Rear glass
	7.11	Safety rod
	7.12	Wheel wedge
	7.13	Block valves
	7.14.1	Load Charts

## 6.2 - Safety stickers

### 6.2.1 - Warnings for safety stickers

Some safety stickers have been applied on the vehicle and equipment in the positions shown below. Their purpose is to provide a guide for your own and others safety. Before starting to work, check the content and location of the stickers indicated on this manual. Review the safety stickers with all operators who will use the vehicle and equipment.



#### ATTENTION

**Make sure to have fully understood their correct location and their contents.**

To ensure proper interpretation verify that they are in the correct position and that they are always kept clean.



#### DANGER

**Clean them when they are covered by mud, concrete or debris.**

It is absolutely forbidden to clean the stickers using solvents or gasoline; the labels may become discolored.

See the summary table in the "Maintenance" chapter for the for safety stickers maintenance and control deadlines.

Replace the safety stickers in case of deterioration, damage or loss, as these must always be read and interpreted correctly.











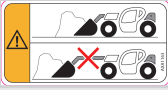
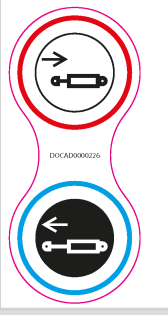
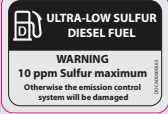

#### WARNING

Do not under any circumstances remove the safety stickers.





#### NOTE

The purchase order of replacement safety stickers must be made in the same way in which any spare part is ordered (be sure to communicate the model and serial number of the vehicle or equipment when placing the order).

SIGNAL	CODE	DESCRIPTION
	AXA1163	Warning: keep the boom fully retracted when digging with buckets
	DOCAD0000226	Boom head hydraulic sockets
	DOCAD0000565	Requested quality of fuel (it may depend on the destination country)
	DOCAD0000142	Requested quality of fuel (it may depend on the destination country)
	AXA2748	Battery maintenance danger
	DOCAD0000054	Switch the engine off for maintenance
	DOCAD0000049	AdBlue filling cap position
	DOCAD0000370	Point where to refuel
	DOCAD0000371	Type of fuel used
	AXA1946	Indicates the tire pressure
	AXA1431	Indicates the lifting points
	AXA1432	Indicates the points at which to anchor the vehicle for transport or towing

SIGNAL	CODE	DESCRIPTION
	AXA1433	Indicates where to check the hydraulic oil level (right)
	AXA1433/1	Indicates where to check the hydraulic oil level (left)
	AXA1434	Indicates where refueling hydraulic oil
	AXA1435	Danger, moving mechanical parts, do not remove the safety guards and wait that the parts have stopped before carrying out any maintenance
	AXA1436	Indicates the position of the safety rod for lifting cylinders
	AXA1438	Indicates vehicle parts that can not be walked on
	AXA1439	Danger moving mechanical parts
	AXA1440	Danger of hot steam under pressure escaping
	AXA1441	Danger of hot surface
	AXA1493 AXA2103	Warning, keep a safe distance
	AXA2709	Battery isolation switch sticker
	DOCAD0000261	Engine hood opening lever indication

SIGNAL	CODE	DESCRIPTION
	AXA1501	Indicates lubrication points
	AXA1506	Compulsory use of seat belts
	AXA1514	Emergency exit
	AXA1515	Remove the cotter pin
	AXA1773	Warning, do not reach high speeds or over-revving the engine in downhill
	AXA2848	Indicates the maximum guaranteed acoustic power
	AXA1572	Upper window release
	AXA2430	Do not stand under the forks or transport people with the forks
	DOCAD0000209	Joystick
	AXA2104	Risk of being run over
	DOCAD0000301	Indicates the vehicle lifting points
	AXA1892	Indicates maximum use of the vehicle in case of wind
	AXA2183	Read the use and maintenance manual
	AXA2708	Type of oil used in the hydraulic system

SIGNAL	CODE	DESCRIPTION
	AXA2798	Type of oil used in the hydraulic system
	DOCAD0000563	Type of oil used in the hydraulic system
	DOCAD0000053	Recommends staying away from electric lines

6.2.2 - Safety stickers position on the vehicle

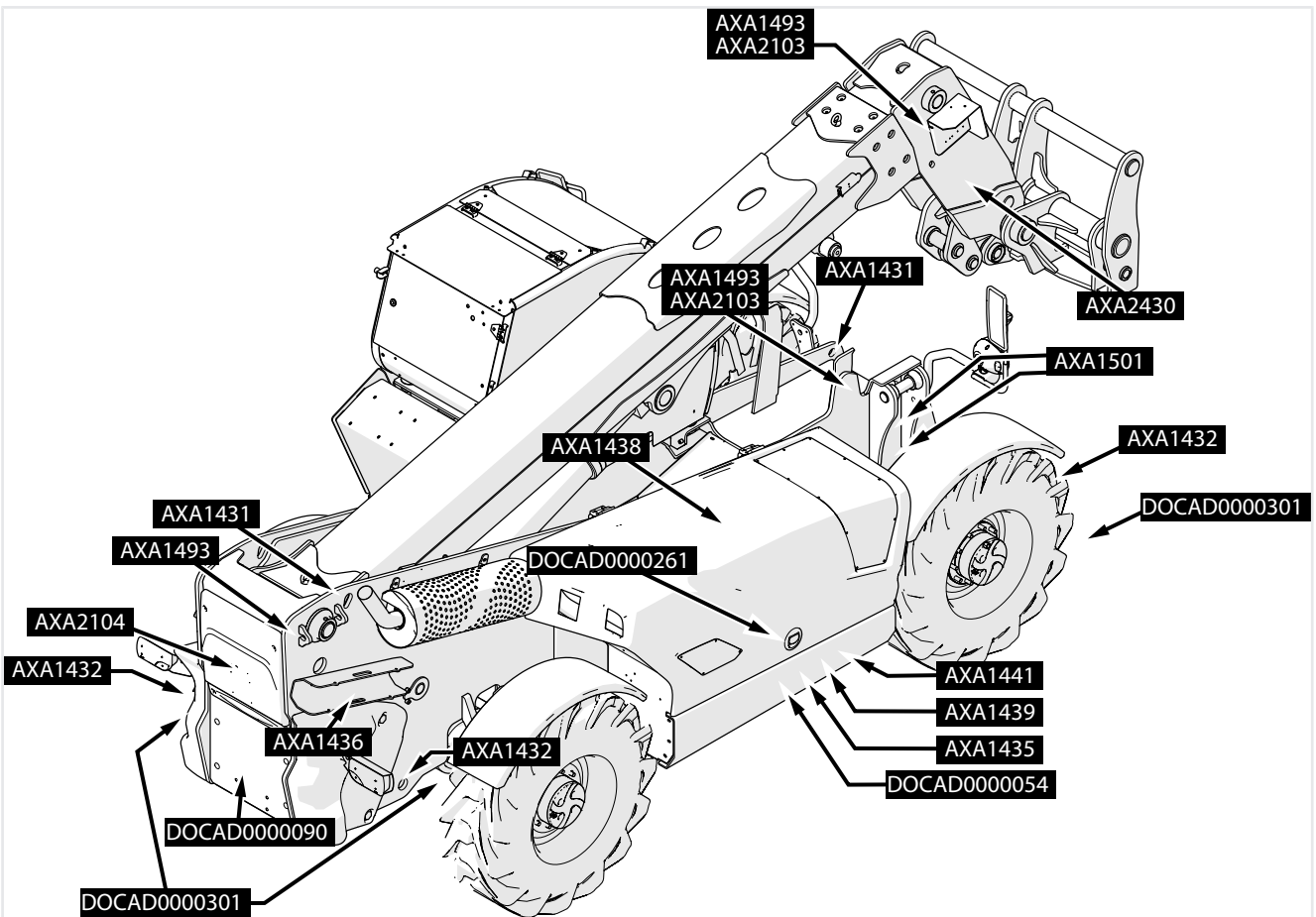
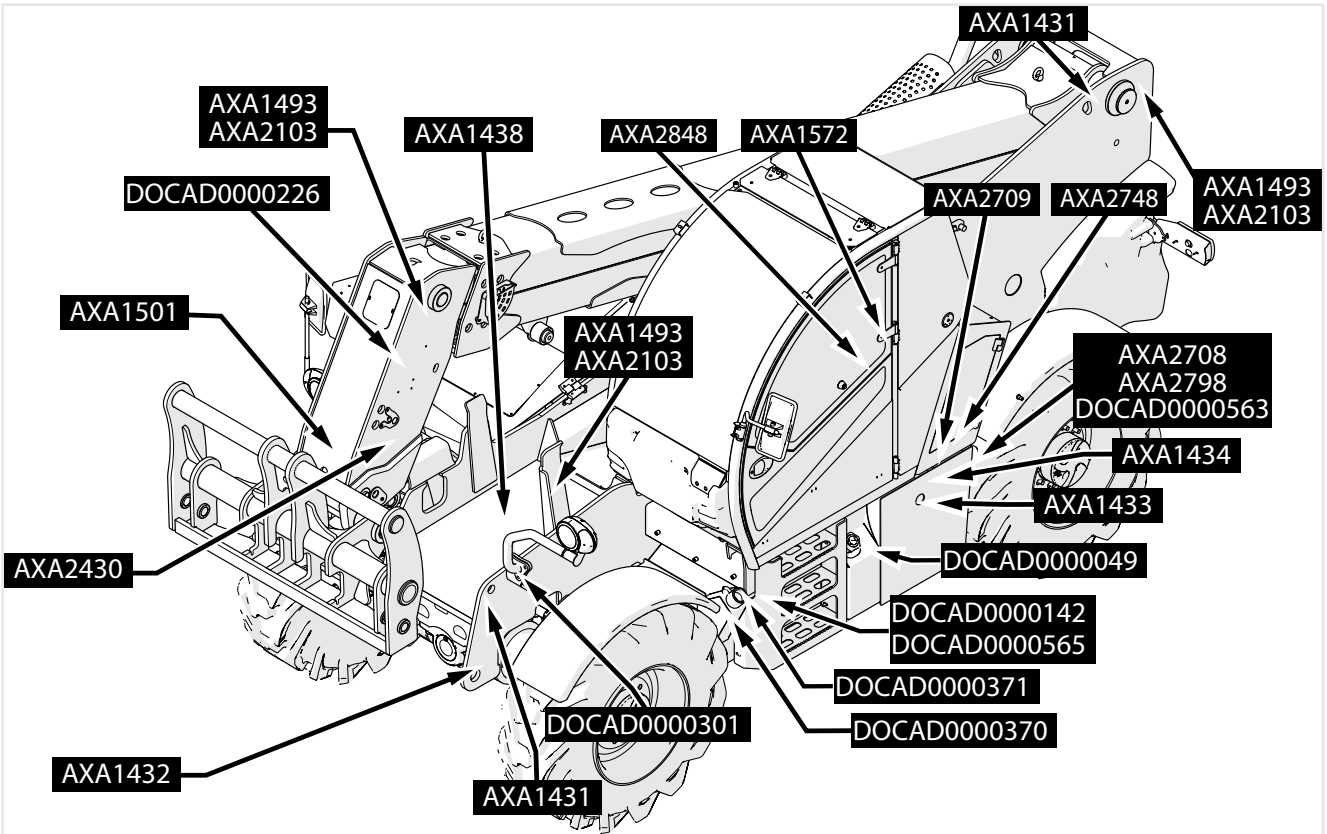

### 6.2.3 - Safety stickers position in the cab

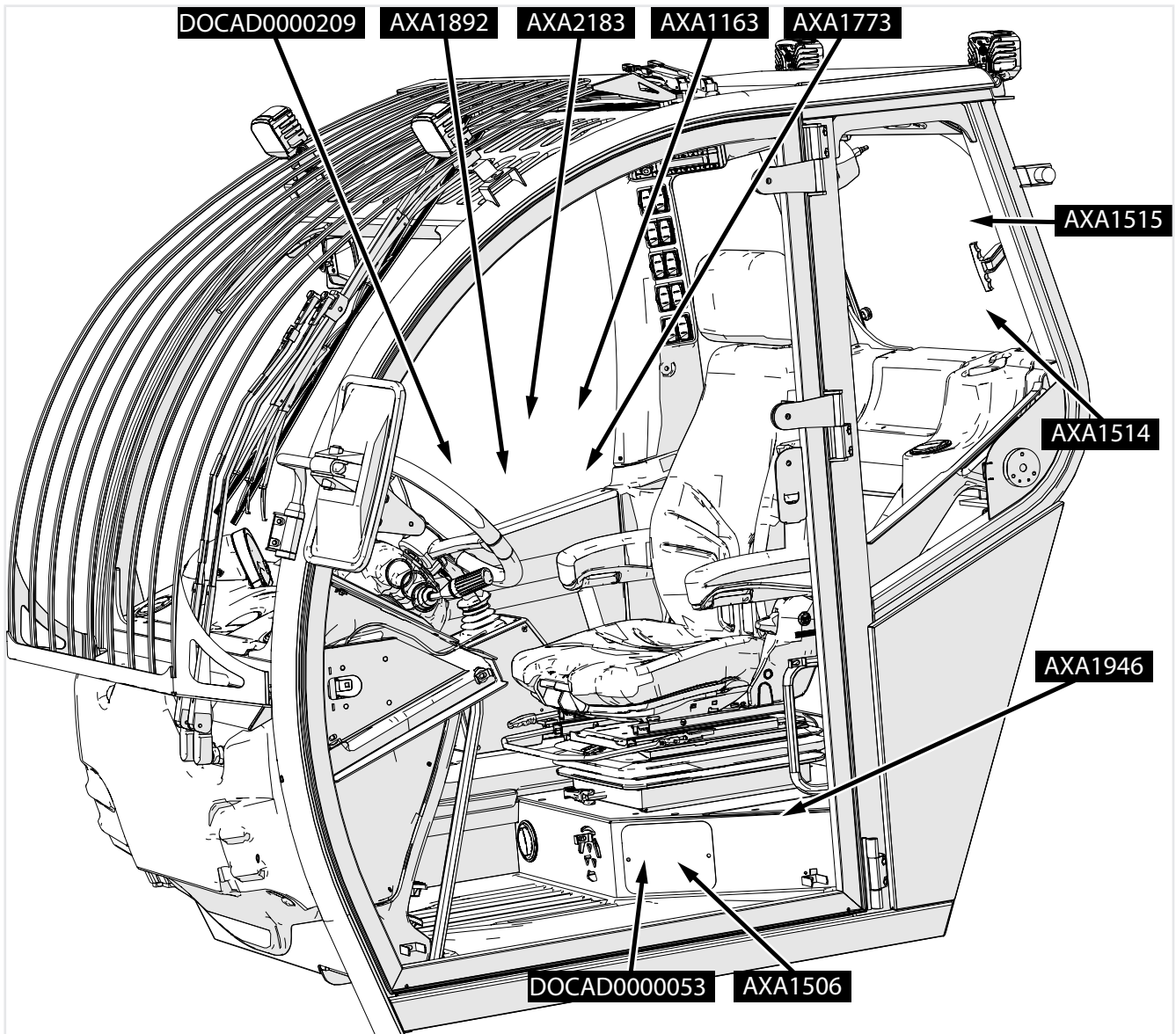



### 6.2.4 - Position of engine safety stickers

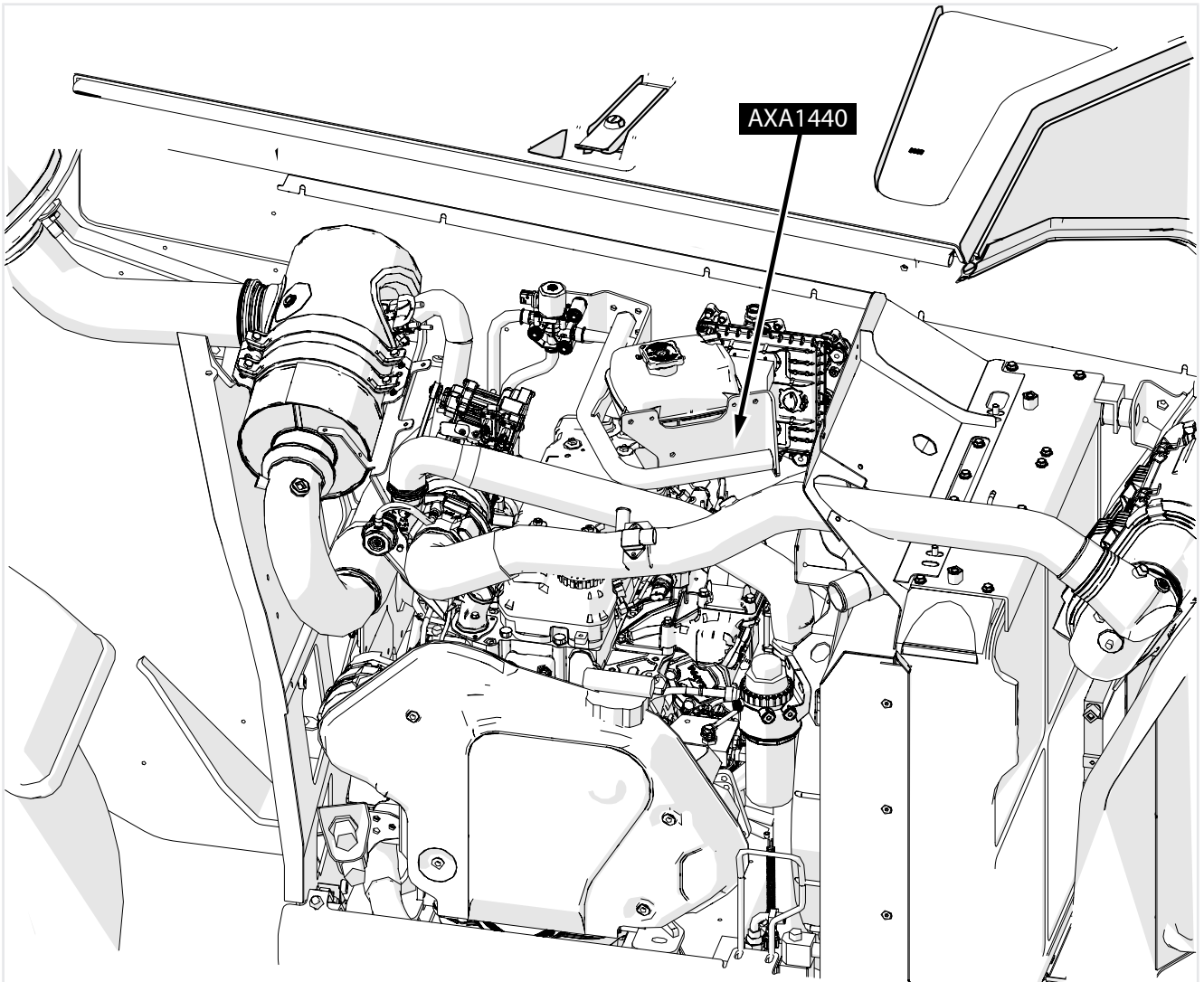

## 7.1 - Cab

### 7.1.1 - ROPS - FOPS Cab

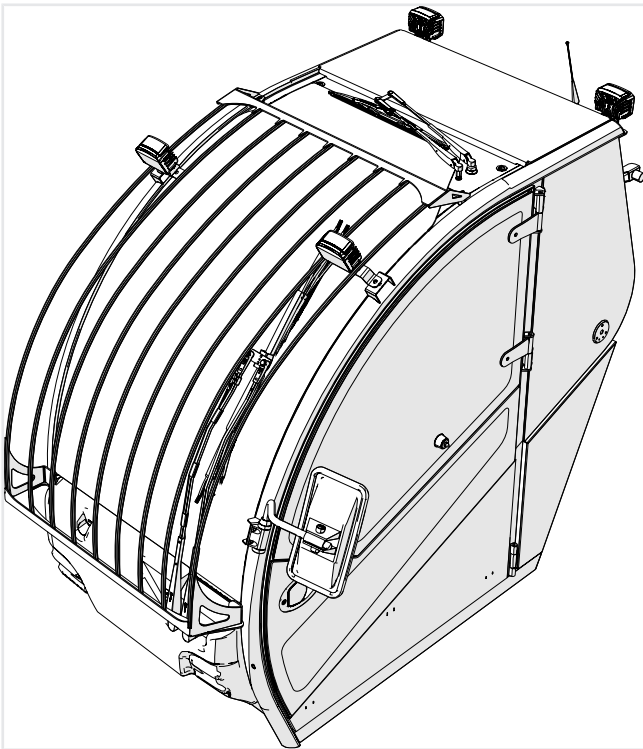

Figure: 170951-1

The vehicle is equipped with an approved cab:

- **ROPS** (Roll Over Protection Structure)
- **FOPS** (Falling Objects Protective Structure)

The operator is therefore protected in the event of vehicle tipping and in the event of falling objects, as prescribed for earth moving vehicles.



### ATTENTION

The cab is a safety device and as such must be always kept in the right conditions of use.

In case of cab tampering, the manufacturer has no civil liability in case of an accident, therefore it is absolutely forbidden to:

- Change, drill, or alter in any way the structure of the cab.
- Weld or mechanically connect parts to the cab chassis.
- If the fastening bolts are replaced, use elements of different strength class.
- Connect chains or ropes to the cab for the purpose of towing.



### WARNING



**In the case of vehicle tipping, staying in the cab with fastened seat belts allows to obtain a better protection.**

If the cab has undergone visual damage it must be replaced by consulting the authorized service center or Dieci authorized workshop.

The cab is classified as: CATEGORY "1"

The cab approved as category "1" does not offer full protection against the ingress of dust, aerosols and vapors. Consult and follow the instructions provided by the manufacturer of the chemicals used (such as pesticides, fungicides, herbicides, etc..) and those supplied by the manufacturer of the sprayer. Use the appropriate personal protective equipment and clothing (PPE) when indicated in these instructions, even when you are inside the cab.



### DANGER



**Inhalation danger for operators and bystanders.**

For protection against harmful dust, aerosols and vapors, refer to the instructions provided by the manufacturer of chemicals, by the manufacturer of the sprayer and to the basic rules contained in this manual.

Refer to the packaging of the product used to use the appropriate protective equipment.

## 7.1.2 - Door opening

### 7.1.2.1 - External door handle

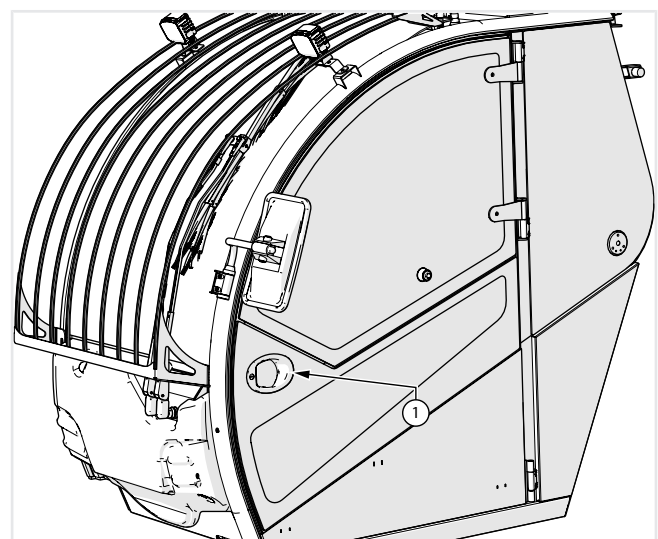

Figure: 150901-1

The door of the cab is equipped with an external handle "1" (fig. 150901-1) with lock.

To open the door from the outside:

- Insert the key into the lock and turn it clockwise/ counterclockwise to engage/disengage the lock.
- Pull the handle towards yourself to release the door with lock disengaged.



**NOTE**

With lock engaged, the door will not open by the handle.



**WARNING**

It is absolutely forbidden to operate with the cab door open.

7.1.2.2 - Internal door handle

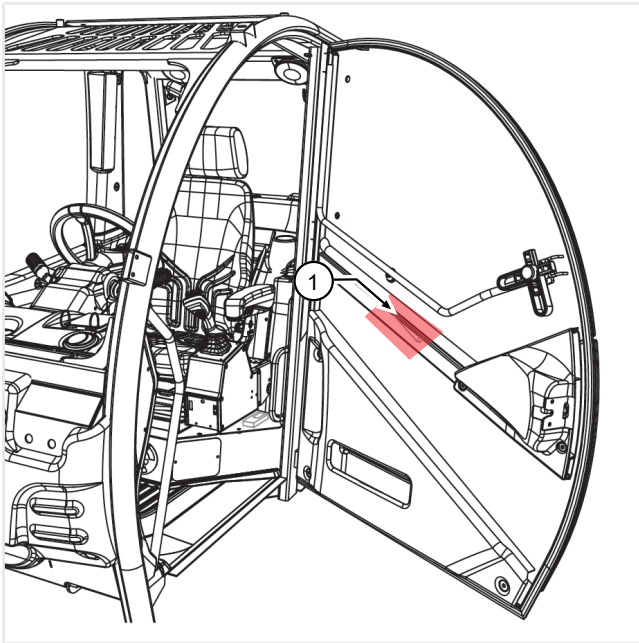

Figure: 150901-2

To open the door from the inside (fig. 150901-2):

- Press the button on the handle to release the door "1".
- Push the door to the outside to complete the opening.
- Accompany the door with one hand while opening it.



**ATTENTION**

Before pushing the door outwards verify that the opening area is free from obstacles of various kinds.

7.1.3 - Climbing in/out



**NOTE**

Before climbing into the cab, make sure your hands and your shoes are clean and dry to avoid slipping and falling.

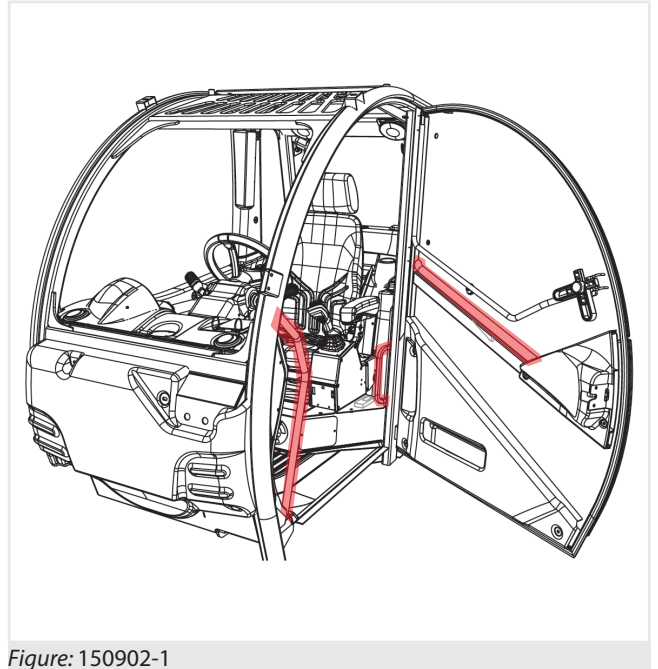

Figure: 150902-1

Use only the appropriate handles and steps to access the cab, do not use the controls and the steering wheel from inside. Climb in and out of the vehicle always turned towards the driver's cab.



**WARNING**

**DANGER**

Climbing in and out of the cab is allowed only when the vehicle is stopped with the parking brake engaged. Do not leave the cab with the vehicle in motion.

### 7.1.4 - Door glass

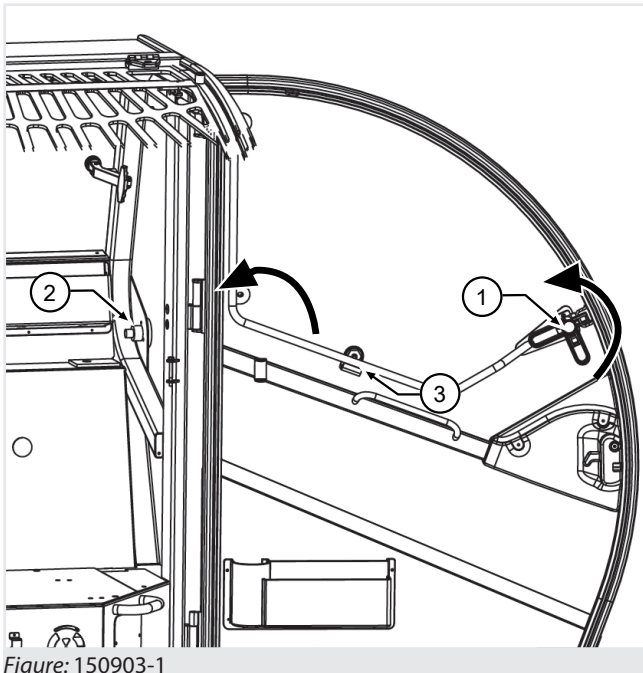

Figure: 150903-1

To open the door glass (fig. 150903-1):

- Lower the grip "1" turning it counterclockwise and pushing the glass outward.
- To stop the glass in the open position push the bolt of the glass "2" inside the fastener "3" pressing slightly.

To close the door glass it is necessary to:

- Press the button inside the pin "3" to unlock the glass and be able to close it.
- To close the glass pull it towards yourself to the starting position.
- Rotate the grip "1" in clockwise direction to lock the glass in the closed position.



#### ATTENTION

**Before opening or closing the glass make sure that the surrounding area is free from obstacles of various kinds.**

Before starting to working make sure that the glass of the door is locked, whether it is in the open or closed position.

### 7.1.5 - Heated mirrors \*



#### NOTE

Heated mirrors are optional attachments.

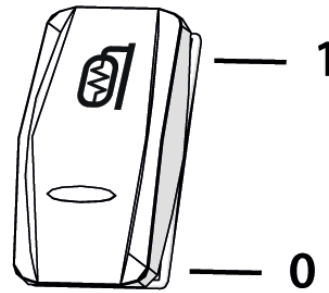

Figure: 160763-1

To start the heated mirrors function press the switch (fig. 160763-1).

The illuminated warning light on the switch indicates that the heated mirrors function is on.

### 7.1.6 - Rear glass

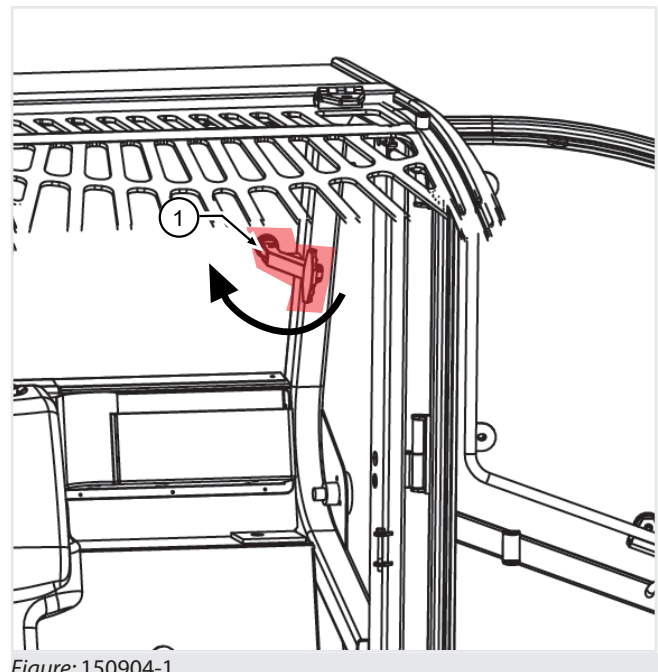

Figure: 150904-1

To open the rear glass, lift the handle "1" (fig. 150904-1) and push the glass outward.

The glass is maintained in the open position by the handle.

To close the rear glass, pull the handle back in the cab and lower until it until the whole unit is completely locked.



#### WARNING

##### Danger of crushing

In case the handle would no longer maintain the open position of the glass, replace it in the shortest possible time.



**NOTE**

The rear glass also serves as an emergency exit, see the "Safety Devices" chapter for more information.

**7.1.7 - Sunshade**

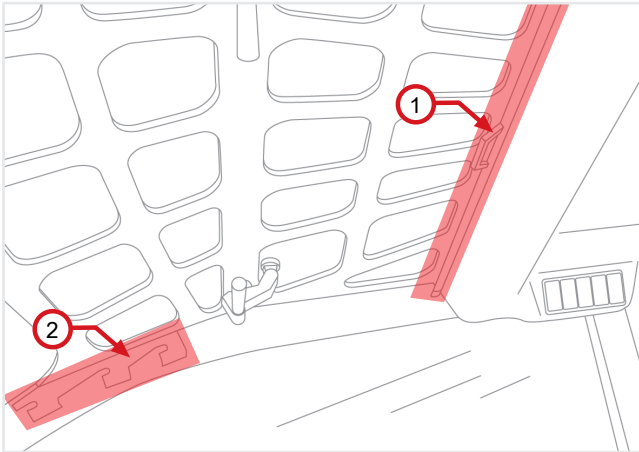

Figure: 170811-1

The Sunshade is located at the top of the cab.

To lower the Sunshade, take the handle located at the center of "1" and lower it down to lock it the hooks provided "2".

To close the sunshade, lower the handle "1" to release it from the hooks "2" and take back the sunshade in closure.

**7.1.8 - Cab ventilation**

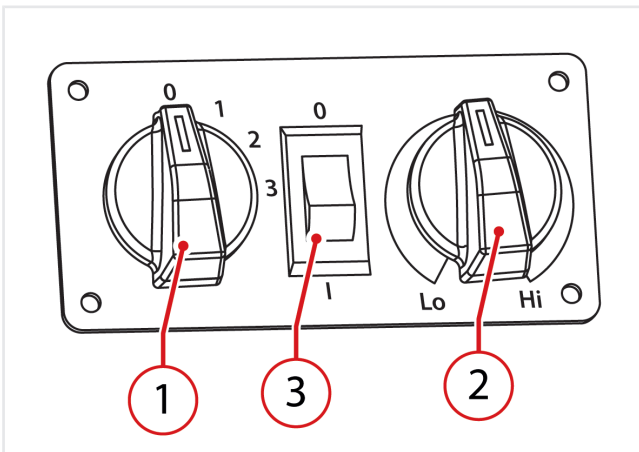

Figure: 161208-1

**7.1.8.1 - Ventilation adjustment**

To adjust the ventilation turn the knob "1" (fig. 161208-1).

Clicks indicate respectively:

0 - Off

- 1 - First speed
- 2 - Second speed
- 3 - Third speed

**7.1.8.2 - Air temperature adjustment**

To adjust the temperature of the air coming out of the vents, turn the knob "2" (fig. 161208-1):

- Turning the knob clockwise (in the red scale) the temperature increases.
- Turning the knob counterclockwise (in the blue scale) the temperature decreases until it is next to the outside temperature.

**7.1.8.3 - Air vents**

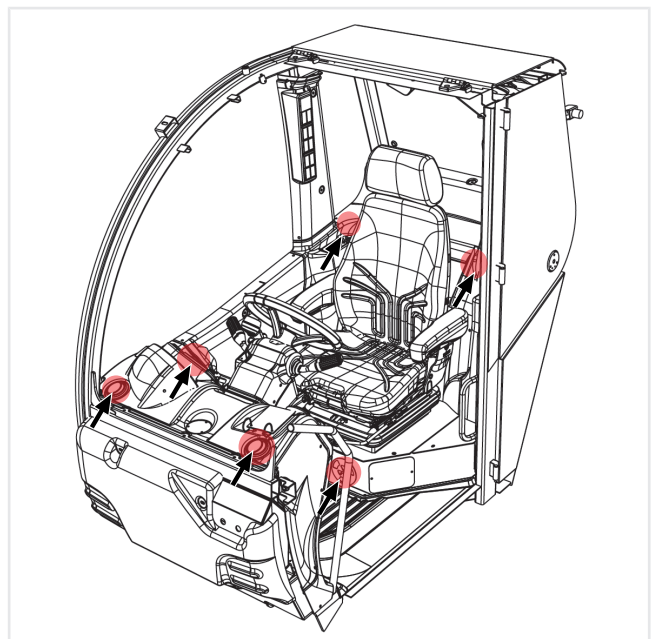

Figure: 150905-1

To open the air vents press on one side of these and adjust the air flow direction using the fins or rotating the vent.

To close the vents push the fins bringing them to the horizontal closing position.

### 7.1.8.4 - Air recirculation inside the cab

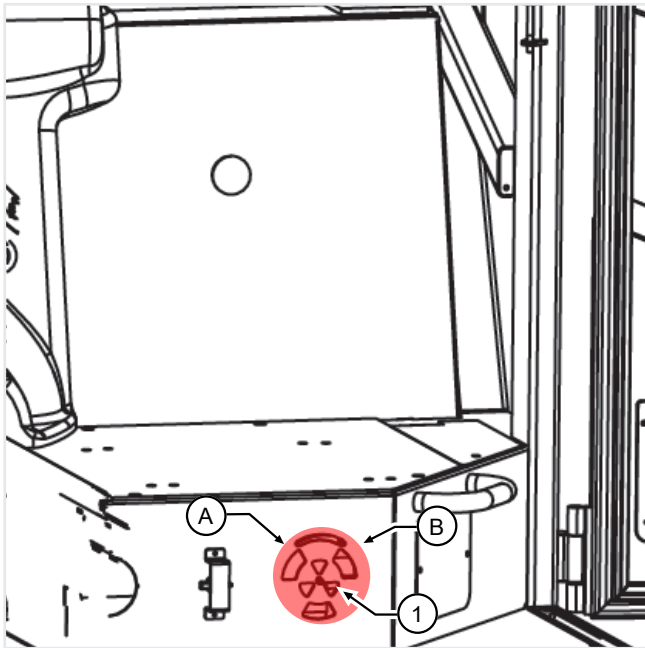

Figure: 170950-1

To enable or deactivate the air circulation in the cab use the lever "1":

- In "A" position to enable air recirculation inside the cab.
- In "B" position to disable the air recirculation inside the cab and allow the ventilation system to draw air from the outside.



#### NOTE

The lever acts on the air "draw" by the ventilation system. The air flow and temperature must always be controlled by the ventilation system inside the cab.

### 7.1.9 - Air conditioning \*



#### NOTE

\* Air conditioning is an optional accessory.

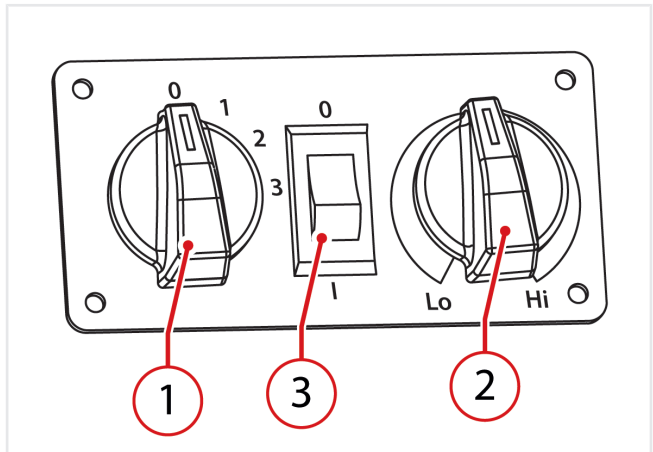

Figure: 161209-1

For a correct use of air conditioning, follow the following steps (fig. 161209-1):

1. Check that all doors and windows are closed.
2. Check that the heater is turned off by moving the lever towards the end of the blue scale.
3. With the engine running, turn on the air conditioning moving the switch "3" in position "I".
4. Turn the knob to adjust the airflow "1" to select the desired intensity.
5. Open and adjust the vents to obtain the best cooling according to the ambient temperature.
6. Turn the temperature knob "2" to obtain the desired temperature.



#### ATTENTION

**Turn on the air conditioning two minutes, every 15 days, even in the colder seasons with the engine idling (without accelerating). In this way the moving parts, such as the compressor and the system in general are lubricated.**

To keep the air conditioning system efficient keep the condenser clean.



#### DANGER

**Do not loosen any hose of air conditioning systems in order to reach the capacitor since the contact between the skin and the refrigerant can cause frostbite.**

For maintenance and deadlines, see the "Maintenance" chapter.

**7.1.10 - Cab lighting**

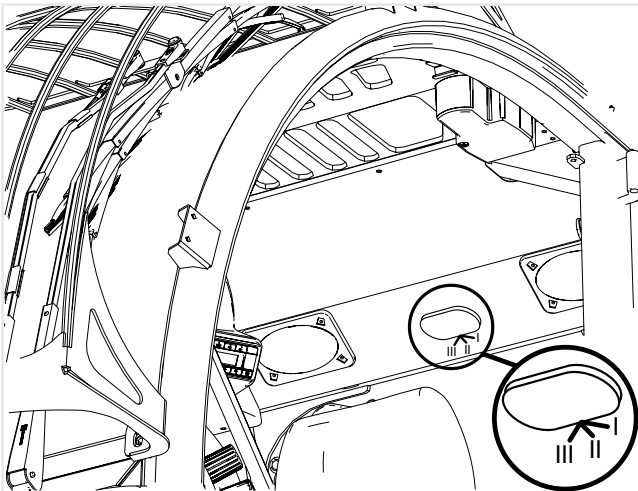

To turn on the internal lighting, act on the overhead light inside the cab.

When the lever is:

- In position "I", the light is steady on, even when the vehicle is tuned off;
- In position "II", the light is always off;
- In position "III", the light turns on when the door gets opened and remains on for a few seconds.



**NOTE**

**In some vehicles, when the door gets opened, the lights in the steps for climbing on the cab and in the pedal group area also turn on.**

**7.1.11 - 12V Socket**

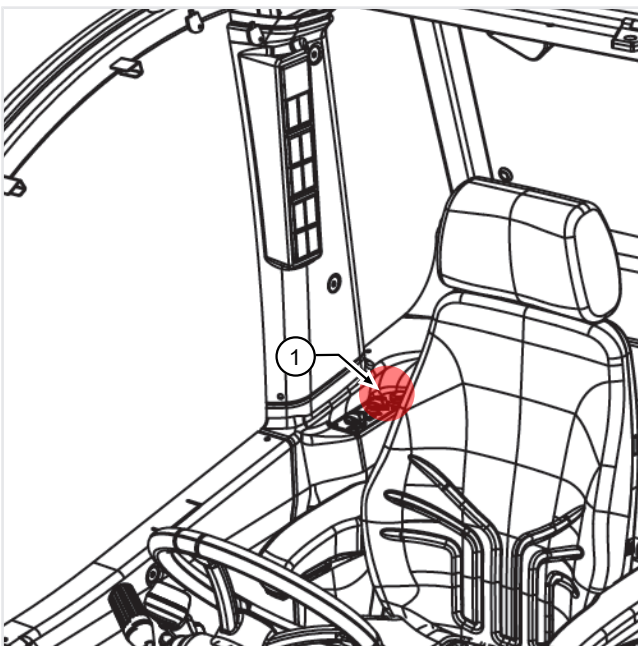

Figure: 150908-1

The 12V-180W socket "1" (fig. 150908-1) allows to connect direct current devices (battery chargers, cell phones, etc.).



**WARNING**

**Do not connect users with nominal voltage greater than 12V and power consumption greater than 180W.**

Risk of damage to the electrical system.

**7.1.12 - Storage compartment**

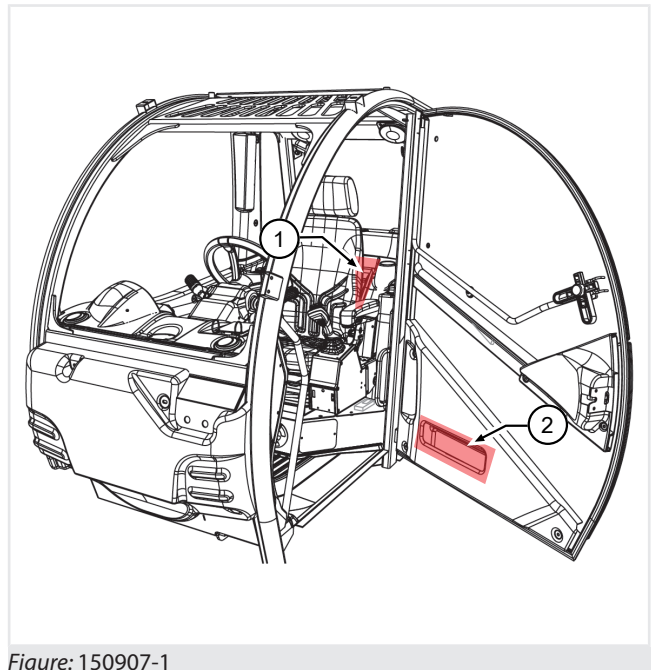

Figure: 150907-1

There are different storage compartments on the vehicle (fig. 150907-1):

1. Behind the seat
2. On the door

**7.1.13 - Steering wheel**

The steering wheel of the vehicle allows steering the vehicle wheels according to the steering mode set.



**NOTE**

Refer to the "Steering selector" chapter.



**NOTE**

The steering wheel is properly adjusted when the operator, with the back firmly against the backrest of the seat, is able to grasp the furthest side of the steering wheel while keeping the elbow slightly bent.

## 7.1.13.1 - Steering wheel tilt adjustment

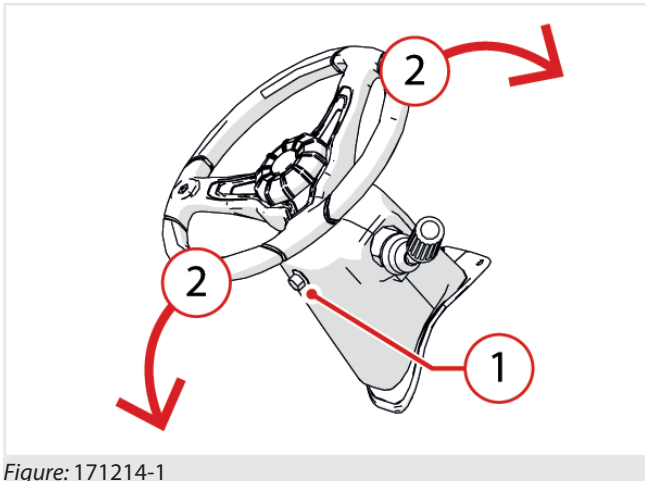

Figure: 171214-1

To adjust the steering wheel tilt (fig. 171214-1):

- Press and hold the button "1",
- Tilt the steering wheel to the desired position "2",
- Release the button "1" to lock the steering wheel.

## 7.1.14 - Multifunction lever

The multifunction lever contains several functions: direction indicators, horn, headlights turning on, window wipers and washers.

## 7.1.14.1 - Direction indicators

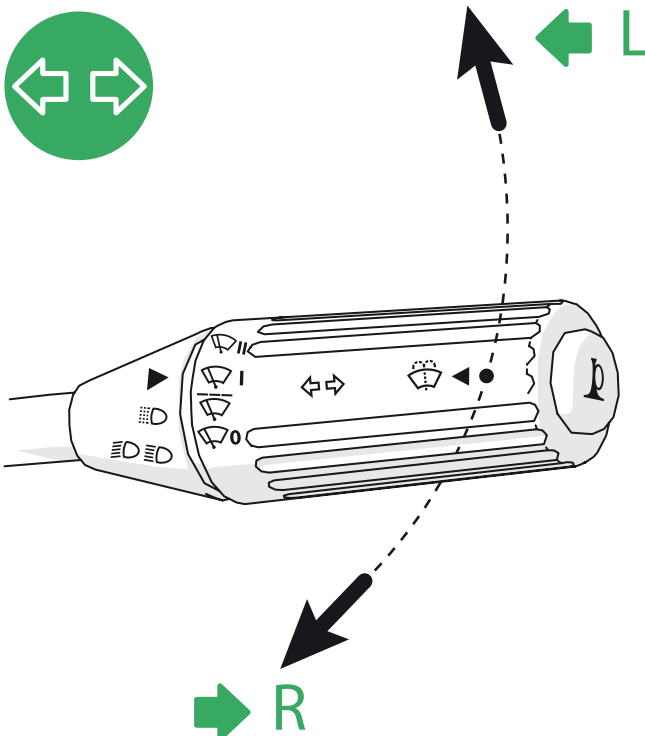

Figure: 150402-1

Move the lever (fig. 150402-1):

- Towards yourself to indicate a curve to the right (R).
- Forward to indicate a curve to the left (L).

The indicators only work when the ignition switch is in the position of instrumentation on.

The indicator light "1" on the central instrument panel will activate the direction indicators.

**ATTENTION**

Push the multifunction lever in stand-by position after making the turn, return to the neutral position is not automatic.

## 7.1.14.2 - Horn

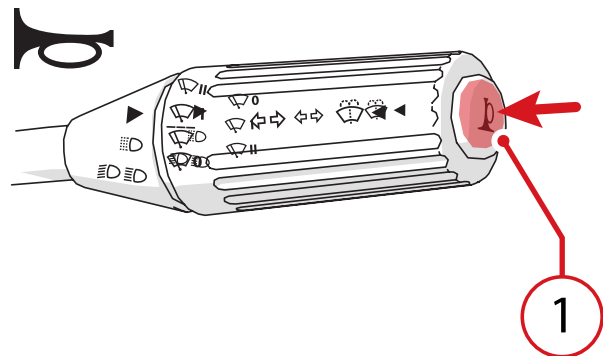

Figure: 150403-1

Press the button on the end of the lever "1" (fig. 150403-1), to activate the horn.

## 7.1.14.3 - Front window wiper

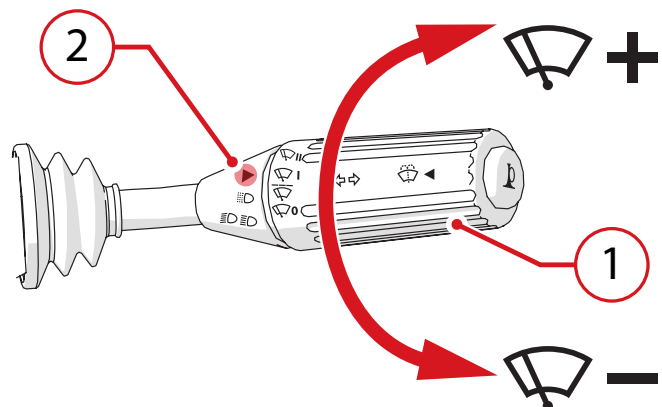

Figure: 150404-1

Turning the knob to "1" (fig. 150404-1) activates the front window wiper.

The arrow "2" indicates which window wiper mode "3" is currently active:

- 0 - Off
- When first activation step is triggered, the wiper operation will be intermittent
- I - Slow



- II - Fast



**WARNING**

**Worn blades cause viewing difficulties and scratches to the glass.**

Replace the blades if they are damaged or worn.

7.1.14.4 - Window washer

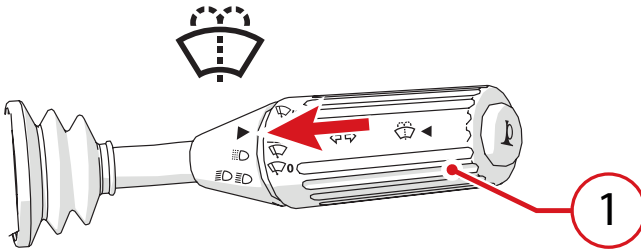

Figure: 150405-1

Press the middle button on the lever "1" (fig. 150405-1) to turn on the front window washer.

7.1.14.5 - Upper and rear window wiper and washer

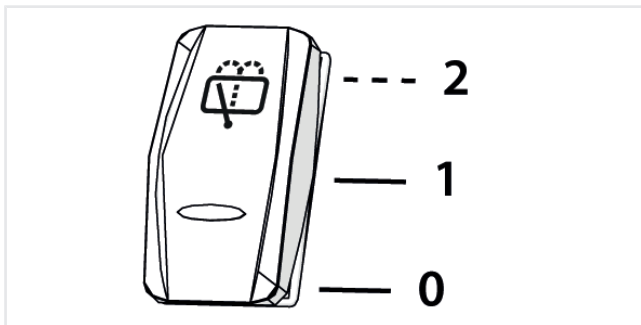

Figure: 150406-1

The switch of the upper and rear window wiper and washer (fig. 150406-1) has 3 positions, 2 of which are stable and 1 unstable:

- 0 - Window wiper off
- 1 - Window wiper on
- (2) - Rear window wiper in operation, until pressed

7.1.15 - Lights turning on

7.1.15.1 - Sidelights and low beam lights

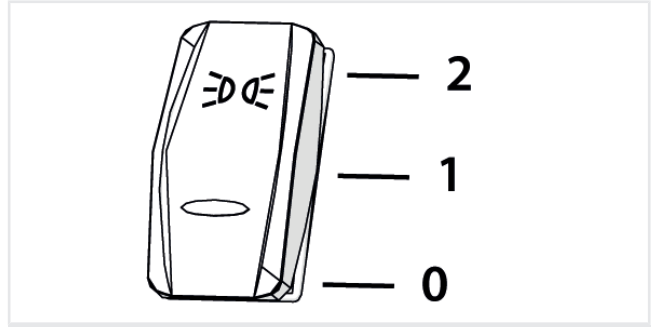

Figure: 171102-1

To turn on the front and rear side lights of the vehicle it is necessary to use the switch on the left instrument panel (fig. 171102-1).

The switch has 3 stable positions:

- 0- Lights off
- 1- Side lights on
- 2- Low beam lights on

The side lights turned on is indicated by the indicator on the led that turns on.

When the side light are activated the instrument panel of the vehicle lights on.



**NOTE**

It is possible to turn on the side lights with the ignition key in "0" position, while it is necessary to bring the ignition key in position "I" to turn on the low beam lights.

7.1.15.2 - High beam lights

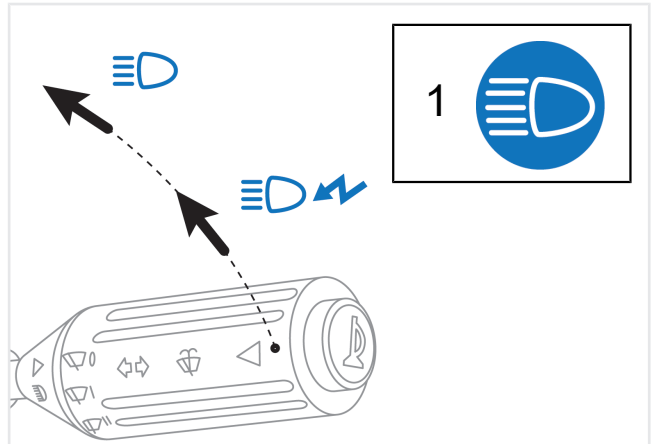

Figure: 150408-1

To turn on the high beam lights it is necessary to move the multifunction lever (fig. 150408-1).

- To make individual flashes with the high beam lights, pull the multifunction lever toward the steering wheel to the first click. It is possible to use this function with the lights off and the ignition key in position "0".
- To turn on the high beam lights, pull the multifunction lever toward the steering wheel to the second click. It is possible to turn on the high beam lights only with the ignition key in position "I" and low beam lights on. The high beam lights turned on is indicated by the warning light "1" on the instrument panel.

In both cases, once obtained the desired click, the multifunction lever returns to its rest position.

### 7.1.15.3 - Cab front light \*



#### NOTE

\* The cab front light is an optional accessory.

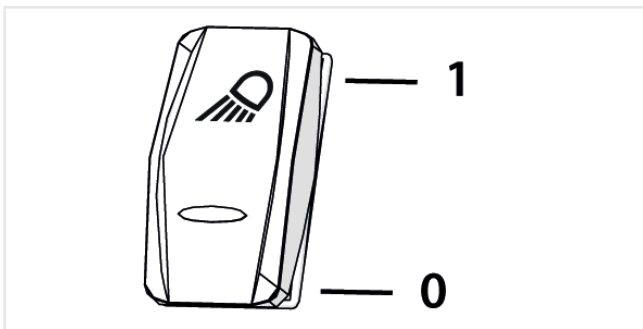

Figure: 150409-1

Press the switch (fig. 150409-1) to turn on the front work light.

The LED on the switch turns on to indicate that the light is on.



#### NOTE

To turn on the headlight it is necessary to bring the ignition key in position "I".

### 7.1.15.4 - Cab rear light \*



#### NOTE

\* The cab rear light is an optional accessory.

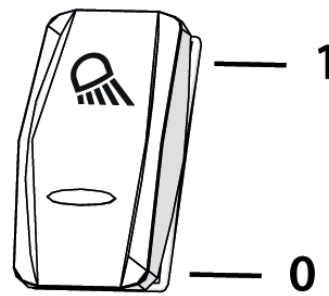

Figure: 150410-1

Press the switch (fig. 150410-1) to turn on the rear work light.

The warning light on the same switch indicates that the light is turned on.



#### NOTE

To turn on the headlight it is necessary to bring the ignition key in position "I".

### 7.1.15.5 - Work light on the boom head\*



#### NOTE

\* The work light on the boom head is an optional accessory.

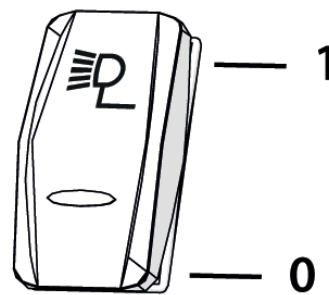

Figure: 150411-1

Press the switch (fig. 150411-1) to turn on the work light on the boom head.

The warning light on the same switch indicates that the light is turned on.



#### NOTE

To turn on the headlight it is necessary to bring the ignition key in position "I".

### 7.1.15.6 - Perimeter lights \*



#### NOTE

\* Perimeter lights are an optional accessory.

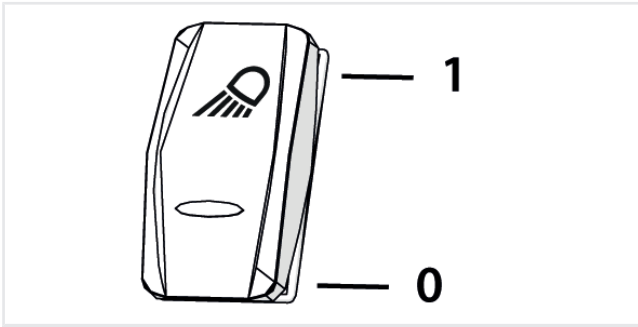

Figure: 150409-1

Press the switch (fig. 150409-1) to switch on the perimeter lights.

The LED on the switch turns on to indicate that the lights are on.



**NOTE**

To turn on the headlight it is necessary to bring the ignition key in position "1".

**7.1.15.7 - Rotating light**

The rotating light is positioned onto the driver's cab.

To activate and position the rotating light, perform the following steps:

1. Clean and dry the top of the driver's cab.
2. Place the rotating light on the cab.
3. Insert the plug of the rotating light into the electrical socket on the rear left side of the cab, under the rear glass.

It is possible to fold the rotating light backwards when not in use.

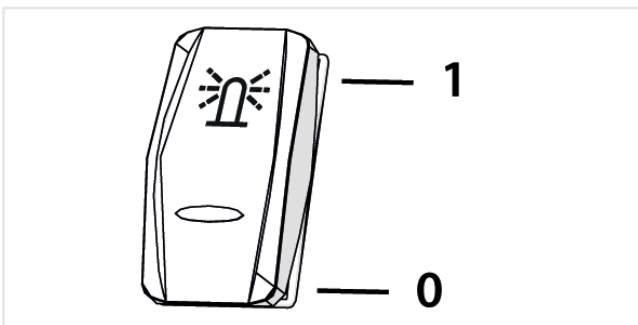

Figure: 171150-2

Press the switch (fig. 171150-2) to activate the rotating light:

- 0 - Rotating light off
- 1 - Rotating light on

The rotating light turned on is indicated by the indicator light on the switch.



**ATTENTION**

**Do not use the rotating light improperly.**

Refer to the manager in charge of the work and to the regulations in force in the country of use of the vehicle to know the cases in which it is necessary and/or allowed to use the rotating light.



**NOTE**

It is possible to turn on the rotating light even if the ignition key is in the "0" position.

**7.1.16 - Emergency Lights**

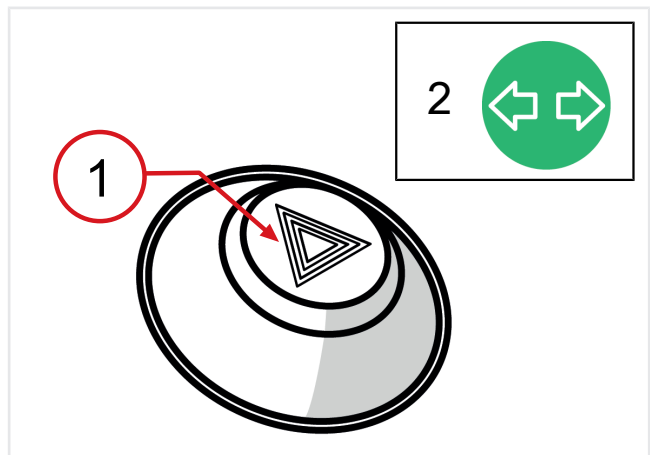

Figure: 150419-1

Press the emergency lights switch "1" (fig. 150419-1) to turn on all four direction indicators.

The side lights turning on is indicated by the switch flashing and by indicator "2" on the instrument panel of the vehicle.

**7.1.17 - Seat**

The seat of the vehicle is equipped with specific safety belts designed to protect the operator during the movement or handling operations.



**WARNING**

Always fasten the seat belts when operating the vehicle.

### 7.1.17.1 - Deadman seat sensor

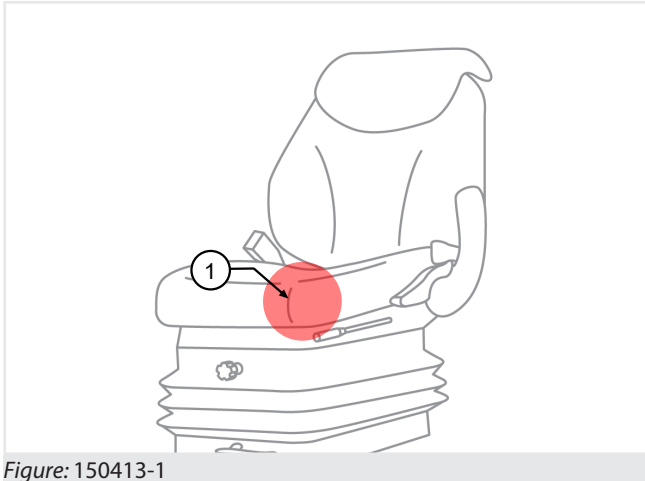

Figure: 150413-1

The vehicle is equipped with a safety system called "deadman" which consists of a magnetic sensor inside the seat cushion "1" (fig. 150413-1).

If the engine is running and the operator is not sitting properly in the driver's seat for a time longer than 3 seconds, the transmission is automatically disabled and the park brake is engaged.

To continue moving the vehicle, the operator must sit in the driver's seat and set the movement selection lever in position "N".



#### NOTE

The engine can be started only if the operator is seated properly in the driving seat and the gear lever is in neutral "N".

### 7.1.17.2 - Seat adjustment



#### ATTENTION

##### Correctly position the seat.

The seat is properly positioned when the operator is able to perform a full stroke to the brake pedal by holding the back against the backrest of the seat itself.

The seat can be adjusted to different positions:

#### Backrest inclination

To adjust the inclination of the backrest (fig. 150418-1), lift the lever on the left side and let the backrest adapt to the required position. Release the lever to block the backrest.

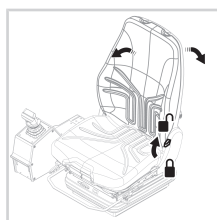

150418-1

#### Back cushion

Adjust the back cushion (fig. 150418-2) by turning the knob behind the backrest.

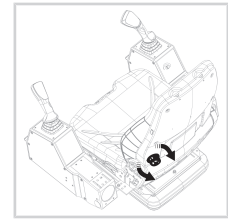

150418-2

#### Horizontal position of the seat unit

Adjust the entire seat unit longitudinally by moving the lever (fig. 150418-3) upwards and sliding the seat unit on the guides. Once established the desired position, release the lever. Perform small movements to make sure that the seat is fastened properly.



150418-3

#### Horizontal seat position

To adjust the seat longitudinally move the lever (fig. 150418-4) upwards and slide the seat unit on the guides. Once established the desired position, release the lever. Perform small movements to make sure that the seat is fastened properly.

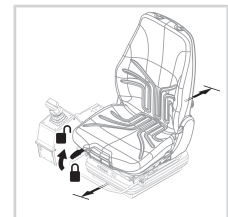

150418-4

#### Horizontal seat position

To adjust the seat longitudinally, press the right handle (fig. 150418-5) and slide the seat along the guides. Release the handle when the desired position is reached. Perform small movements to make sure that the seat is secured properly.



150418-5

**Seat inclination**

To adjust the seat inclination, press the left handle (fig. 150418-6) and adjust the seat to the desired position. Release the handle when the desired position is reached. Perform small movements to make sure that the seat is secured properly.



150418-6

**Mechanical suspension degree**

To adjust the degree of suspension (fig. 150418-7), turn the knob towards "+" to soften the suspension. Turn the knob towards the "-" to harden the suspension.

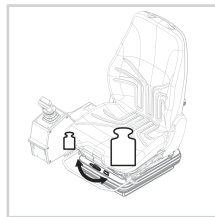

150418-7

Optimal adjustment is achieved when the weight indicated at the side of the lever corresponds to the weight of the operator.

**Pneumatic suspension degree \***



**NOTE**

The pneumatic suspension of the seat is an optional accessory.

To adjust the pneumatic spring rate, pull the knob (fig. 150418-8) to let out pressure and soften the suspension. Push the knob to add pressure and harden suspension.

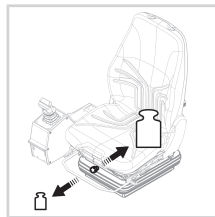

150418-8

Pneumatic adjustment can only be performed with the engine running.

**Adjusting the armrest**

It is possible to lift or lower the armrest by hand (fig. 150418-9).

To adjust the height of the armrest when it is down, turn the knob located under it to the right to raise it, or to the left to lower the armrest.

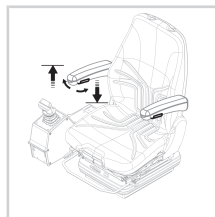

150418-9

**7.1.17.3 - Seat belts**



**WARNING**

**Always fasten the seat belts when operating the vehicle.**

The vehicle is equipped with a cab that can withstand the weight of the vehicle in the event of rollover (ROPS), it is therefore necessary that the operator remains tied to the seat by the seat belt not to be swept out and possibly crushed.

Before starting the vehicle, carefully examine the belts, buckles and fastening devices to the structure. If some component is damaged or worn, replace the seat belt or the component before operating the vehicle.

Remain seated with the seat belts fastened properly for all the time of operation of the vehicle to reduce the risk of injury in case of accident.

Following an accident of a certain importance, replace the seat belts, even if they do not appear damaged.

To fasten the seat belt is necessary to:

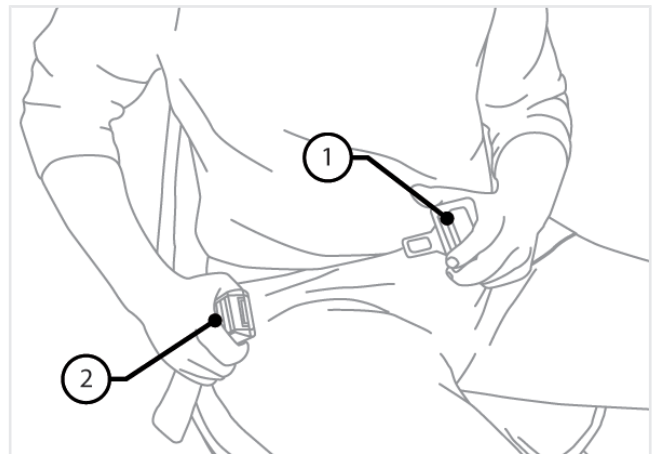

Figure: 150416-1

- Insert the tab "1" in the buckle "2".

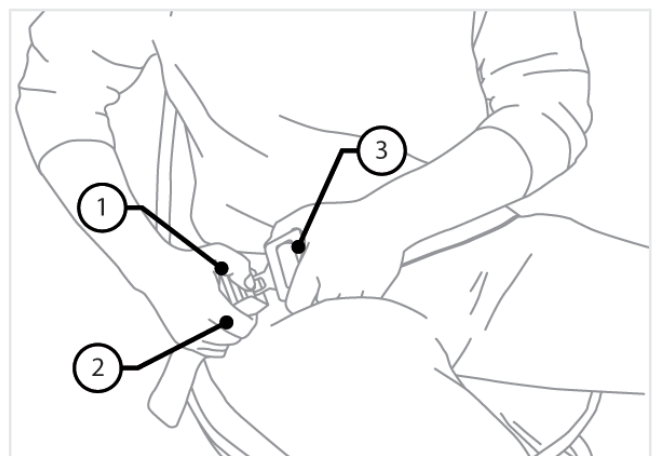

Figure: 150416-2

- Make sure of that the hooking occurred, and then adjust the belt around the body.
- The belt is considered properly connected when it is close to the body.

To remove the belt it is necessary to:

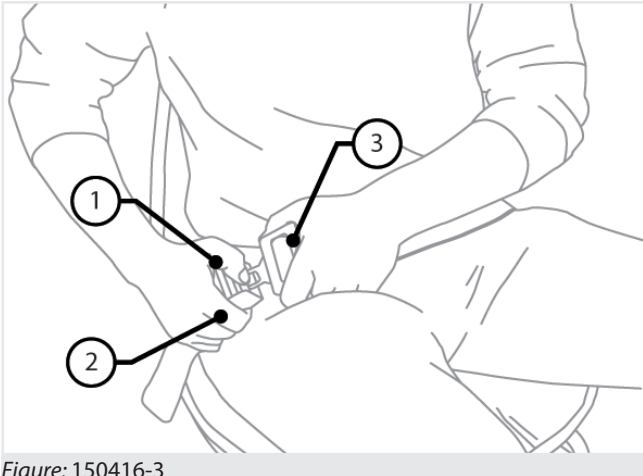

Figure: 150416-3

- Press the red button "1" on the buckle "2".
- Then remove the tab "3".



## WARNING

**Drive the vehicle only with safety belt properly worn, fastened and adjusted.**

Operating without the seat belt fastened increases the risk of accidents.

Do not use damaged or worn seat belts. If worn, damaged or yielded belts are used, they can break or yield in case of collision resulting in serious injury to the operator.

### 7.1.18 - Emergency stop



In emergency conditions, the machine can be stopped using the Emergency stop buttons.



## ATTENTION

It is recommended to use the emergency stop button only in case that there is an immediate danger to the operator, to the load and/or to the integrity of the vehicle.

The pressure exerted on the emergency stop button activates the power supply cut-off and the consequent complete shutdown of the vehicle and any connected equipment.

The return to normal working conditions, after a stop caused by the emergency stop button, is only possible after:

- Removal of the cause that caused the stop
- Releasing the emergency stop button

To release the emergency stop button, rotate it in the direction indicated by the arrow printed on the button.

### 7.1.19 - Spirit Level

The spirit level is located in the center of the instrument panel. It is used to verify the correct transverse leveling of the vehicle.



Figure: 150421-1

To safely operate the spirit level must in the center, with a maximum approximation of 2° to the right or left.

In the standard spirit level, the angle exceeds 2° when the spirit level moves completely outside the 2 limit marks of 2°.



**DANGER**



**DANGER OF TRANSVERSE TIPPING.**

To safely operate the spirit level must in the center, with a maximum approximation of 2° to the right or left.

**7.1.20 - Emergency exit: Rear glass**

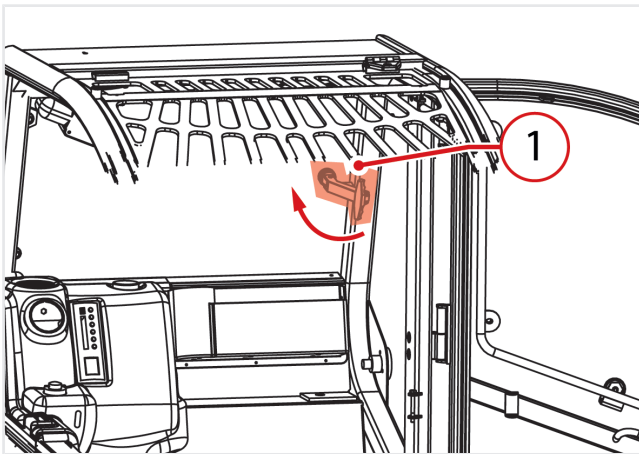

Figure: 150422-1

The rear glass of the cab (fig. 150422-1) can be used as an emergency exit in case the vehicle doors are locked.

To open the window fully, slide the fastener to "1" and push the glass outward.

The fastener must always be positioned as shown in the figure during normal work operations.



**DANGER**

**Danger of crushing.**

It is prohibited to fully open the glass during the use of the vehicle, because of the shearing risks between the boom and the chassis.

The rear glass is near the telescopic boom.



**WARNING**

Be very careful when opening and/or removing the glass, as this may chip or crush and may cause injury to the operator in the cab and to who is near the vehicle.

**7.1.21 - Cab front glass protection \***



**NOTE**

\* **The windscreen protection grill is an optional accessory.**

Consult your dealer in case of doubts or information on your vehicle.

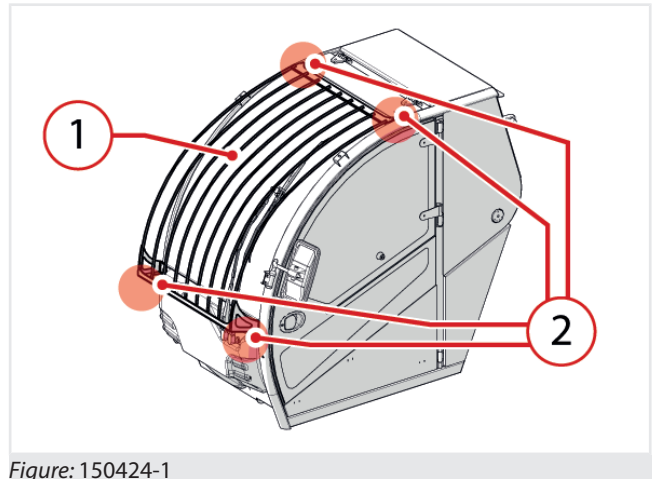

Figure: 150424-1

The Cab front glass protection "1" (fig. 150424-1) provides a higher protection level against any large/heavy loads or objects, which may fall on the cab.



**ATTENTION**

**Driving the vehicle on public roads is allowed only with the Cab front glass protection disassembled.**

Carry out the following operations to disassemble the cab front glass protection:

- a) Lay the load, if any, on the ground,
- b) Place the vehicle on a level ground,
- c) Lift the vehicle boom,
- d) Turn off the vehicle,
- e) Get off the vehicle and climb on the walkable surface on the front of the vehicle,
- f) Loosen the knobs "2" (fig. 150424-1) that fasten the Cab front glass protection, starting from the top,
- g) Lift the Cab front glass protection and place it on the floor.

**7.1.22 - Warnings in case of vehicle tipping**

- The seat belt is the best guarantee of protection for you in case of lateral or front tipping of the vehicle

- Stay calm: stay on board, do not try to jump out of the driver's seat
- Hold the steering wheel with both hands
- Push your feet strongly on the floor, keeping them within the driver's seat
- Tilt your body in the opposite direction to that of the fall
- To avoid head impact, move your head as much as possible towards the steering wheel

## 7.2 - Parking brake

### 7.2.1 - Parking brake description

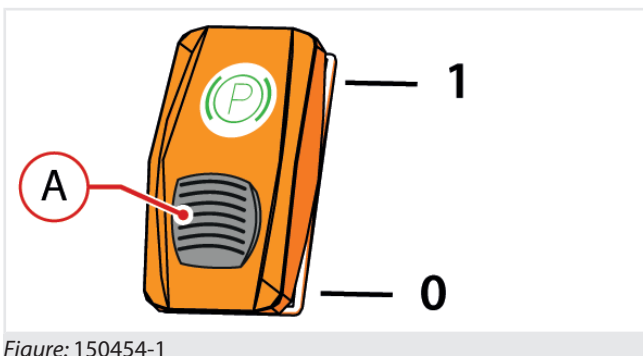

Figure: 150454-1

To engage the parking brake, lift the block "A" and simultaneously press the switch on the side "1" (fig. 150454-1).



150454-2



150454-3

The parking brake properly engaged is indicated by the lighting of the switch and by the indicator on the instrument panel of the vehicle (fig. 150454-2).

With the parking brake engaged, the vehicle cannot move; the hydrostatic transmission is switched off and the wheels are braked.

To disengage the parking brake, press the switch from side 0.

The parking brake must be engaged:

- Every time the operator leave the vehicle, even in case of momentary stop
- Whenever the vehicle operates from a standstill even with outriggers down (if any)
- To start the engine

The brake engages automatically when the engine is stopped.



### WARNING

Unauthorized modification of axle ratios, vehicle weight, size of wheels and tires can affect the parking brake efficiency.



### NOTE

To verify the parking brake efficiency contact a *DIECI* authorized workshop.



### DANGER

**DANGER: In case of failure of the parking brake do not use the vehicle.**

If the warning light (fig. 150454-3) turns on intermittently, it indicates a low brake fluid level.

If the warning light (fig. 150454-3) turns on in a fixed way, the parking brake is stuck or damaged.

Do not use the vehicle until the problem has been solved. Contact a *Dieci* service center.

### 7.2.2 - Braking circuit errors list



### NOTE

In case the vehicle is in error, contact a *Dieci* service center to solve the problem, indicating the error code reported.

For more information about the errors display, refer to the "Instrument panel" chapter.

Icon	Example	Description
	00000000	Parking brakes errors or brakes failure
Code	Description	
100	Service brake low oil level reporting (brake oil tank)	
101	Parking brake system failure	
102	Parking brake accumulator low pressure	



**7.2.3 - Deactivating the internal parking brake manually**

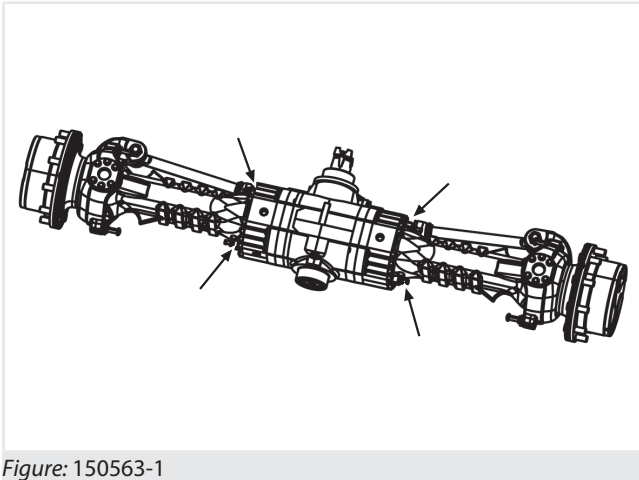

Figure: 150563-1

The parking brake must be disengaged directly on the axle to allow the vehicle to be towed.

- Place safety wedges under the wheels to prevent the vehicle from moving suddenly
- Loosen the lock nuts on both sides of the central body of the axle.
- Tighten the screws until they meet resistance; check the turns made in order to return the screws into the starting position when the towing operations are completed.
- Tighten the screws further 1.5 turns.
- In this way the brake will be released. After the towing return everything to the initial conditions.

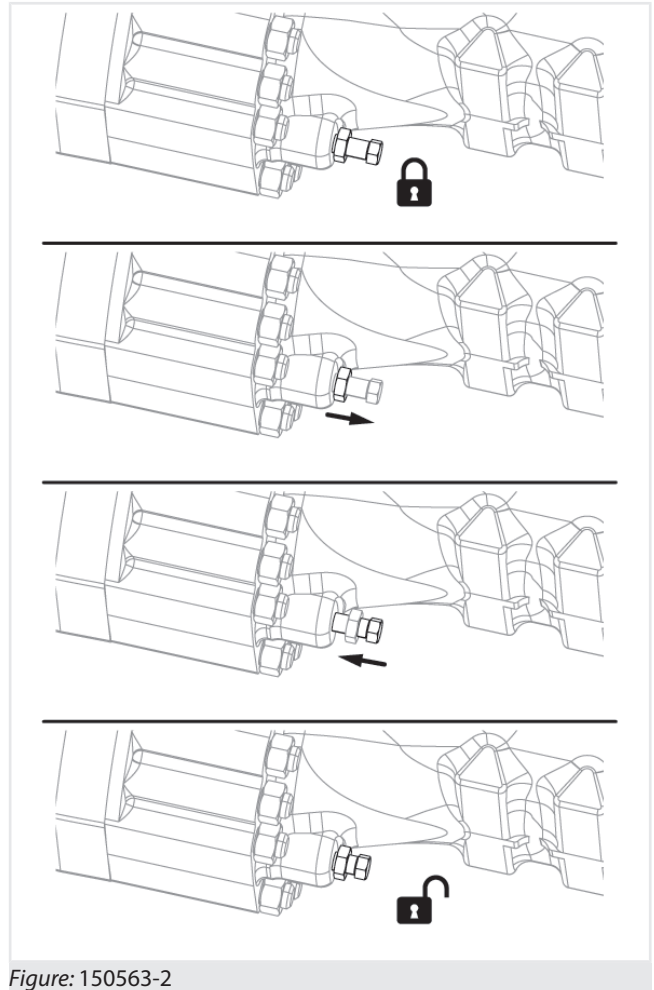

Figure: 150563-2



**DANGER**

**Never use the vehicle with the negative parking brake disengaged/disconnected.**

After the towing return everything to the initial conditions.

It is very important to re-tighten the screws with the same number of turns with which they are loosened.

## 7.3 - Instrument panel

### 7.3.1 - Components

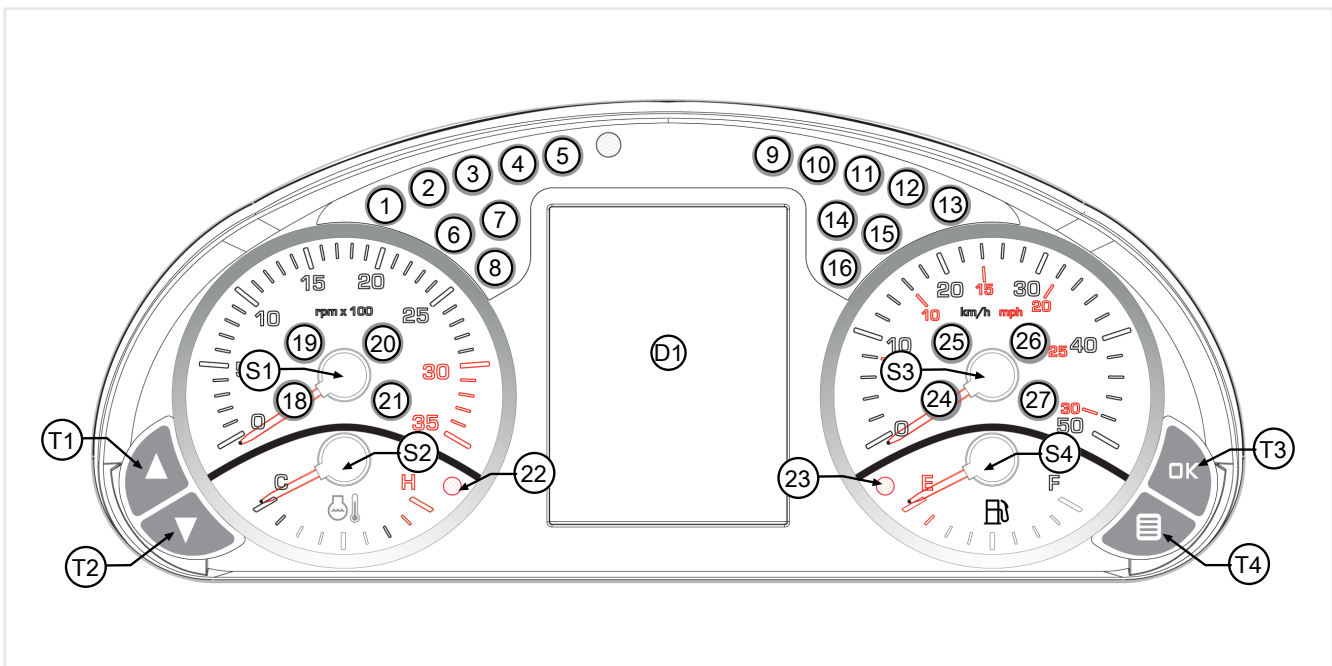

















Figure: 150425-1 - Instrument panel components

Position	Indicator light			Description
T1	-	-	-	UP button
T2	-	-	-	DOWN button
T3	-	-	-	OK button
T4	-	-	-	MENU key
D1	-	-	-	Display
S1	-	-	-	Tachometer indicator
S2	-	-	-	Engine water temperature indicator
S3	-	-	-	Speed indicator
S4	-	-	-	Fuel level indicator
1		Red	Fixed	Generator, battery failure
2		Red	Fixed	Presence of water in the fuel filter
3		Red	Fixed	Engine air filter clogging
4		Yellow	Fixed	Engine pre-heating
5		Red	Fixed	Engine oil low pressure
6		Yellow	Fixed	Engine warnings present
7		Red	Fixed	Engine errors present, engine in limited power mode

Position	Indicator light		Description	
8		Green	Fixed	Forward movement engaged
9		Yellow	Fixed	DPF regeneration in progress (during regeneration the engine idle speed increases)
10		Yellow	Fixed	Automatic DPF regeneration disabling
11		Yellow	Fixed	Medium level of soot
		Flashing	DPF regeneration requested: - Slow flashing: high level of soot; - Fast flashing: critical level of soot	
12		Yellow	Fixed	Inducement warning for low level of AdBlue
		Flashing	- Slow flashing: moderate inducement for low level of AdBlue; - Fast flashing: critical inducement for low level of AdBlue	
13		Yellow	Fixed	Low inducement for AdBlue technical error
		Flashing	- Slow flashing: moderate inducement for AdBlue technical error; - Fast flashing: critical inducement for AdBlue technical error	
14		Yellow	Fixed	Inducement warning for AdBlue low quality
		Flashing	- Slow flashing: moderate inducement for AdBlue low quality; - Fast flashing: critical inducement for AdBlue low quality	
15		Red	Fixed	Inducement active at Level 1
		Flashing	- Slow flashing: inducement active at Level 3; - Fast flashing: inducement active at Level 5	
16		Green	Fixed	Backward movement engaged
18		Blue	Fixed	High beam
19		Green	Fixed	Direction indicators
20		Red	Fixed	Parking brake engaged
21		Green	Fixed	Side lights
22	-	Red	-	Engine water high temperature
23	-	Yellow	-	Fuel reserve
24		Red	Fixed	Hydraulic oil high temperature
25		Red	Fixed	Hydrostatic oil filter clogging
26		Red	Fixed	Parking brake insufficient pressure
27		Red	Flashing	Brakes oil low level
		Fixed	Braking system failure	

### 7.3.2 - Initial loading

When the panel is switched on, the system will perform a check of all the indicator lights and all the indicators. During the check, on the screen there will be a loading bar "1" (fig. 180343-1).

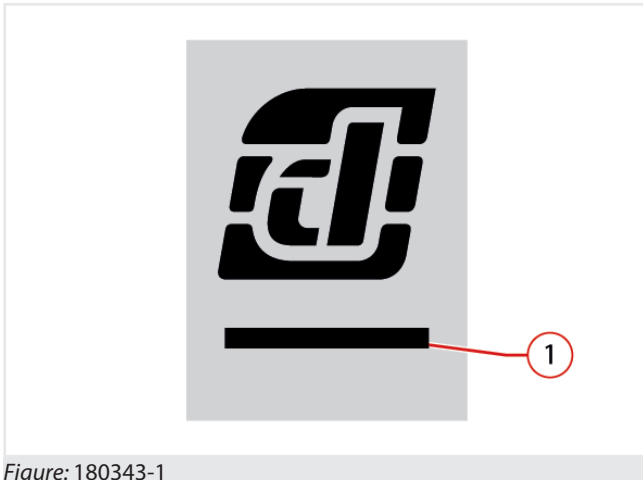

Figure: 180343-1

After completing the initial check the display shows the main Home screen.

### 7.3.3 - Display

The Home screen (fig. 180339-1) is the standard display, containing the information required by the operator to use the vehicle.

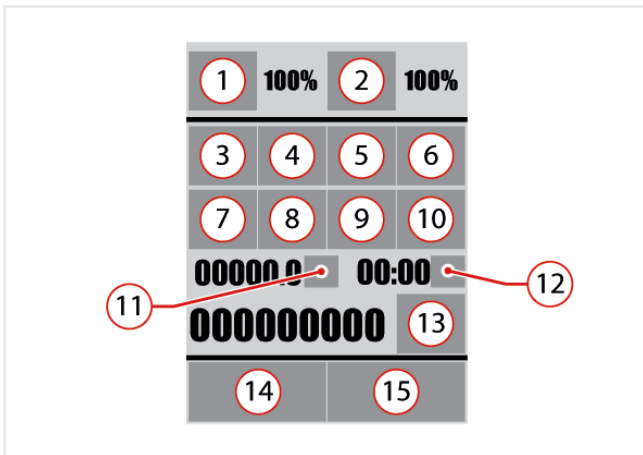

Figure: 180339-1

Position	Description
1	Equipment capacity * [ ▶ 84]
2	Longitudinal momentum indicator
3	General alarm icon
4	Transmission Icon [ ▶ 86]
5	Anti-tipping device ByPass icon [ ▶ 86] Seat Switch icon [ ▶ 87] Wheels alignment check icon * [ ▶ 87]
6	Outriggers icon *

Position	Description
7	Lifted boom icon Active regeneration icon ECO icon
8	Service [ ▶ 85]
9	Not connected man basket icon * [ ▶ 87] Boom Chains Error icon * Levelness Icon * [ ▶ 87]
10	Hydraulic sockets on boom head icon * [ ▶ 87]
11	Hour meter [ ▶ 86]
12	Clock [ ▶ 86]
13	Active errors [ ▶ 89]
14	AdBlue quantity
15	DPF level

\* Icons present depending on the optional equipment.

### 7.3.4 - Equipment capacity \*



#### NOTE

**\* The Equipment capacity icon is part of an optional attachment.**

Refer to the Automatic Equipment Recognition chapter.

The Equipment capacity icon indicates the working mode in which the vehicle is set and the capacity percentage of the equipment installed.

Icon	Description of the mode
	<b>Forks</b> The Forks mode is enabled when using equipment without an equipment recognition system. No capacity percentage is shown.
	<b>Lifting equipment with limiter</b> The Lifting equipment mode is enabled when using equipment with flow limiter. The equipment capacity percentage is displayed.
	<b>Man Baskets</b> The Man Basket mode is enabled The basket capacity percentage is displayed.
	<b>Equipment recognition error</b>

Icon	Description of the mode
	In the event of an error in the automatic equipment recognition system, the forks mode is enabled and no capacity rate is shown.  Check the correct installation of the equipment and contact the reference service center to resolve the error.

**7.3.5 - General alarm icon**

The general alarm icon (fig. 150430-1) lights on together with other signals, to underline danger to the safety of the vehicle or the operator



150430-1

If the vehicle is in motion, the General alarm icon is accompanied by a general alarm acoustic signal.

General alarm icon	Acoustic signal	Condition
On	Intermittent	Generator, battery failure
On	Intermittent	Engine oil low pressure
On	Intermittent	Engine air filter clogging
On	Intermittent	Hydrostatic oil filter clogging
Intermittent	Continuous	Reached engine overspeed limit
Intermittent	Continuous	Reached maximum speed limit

**7.3.6 - Service**

The **Service indicator light (every 500h)** indicates the intervals the maintenance has to be carried out.

20 hours before the deadline, the icon stays on for 30 seconds after switching on the instrument panel.

The icon stays on permanently until maintenance is carried out by specialized personnel.

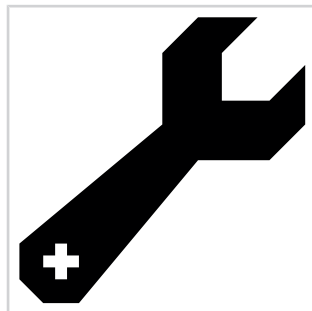

Service Indicator Light

After completing the maintenance, the specialized technician will perform the reset.

The fault state of **supply fuse** gets activated if any of the following inputs is missing when the tool is on:

- +15
- +15 fuse
- +30 fuse

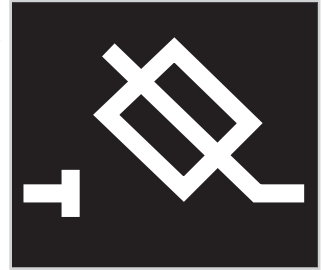

Fuse +15 and +30 state

The **Equipment service** icon represents the state of the programmed maintenance.

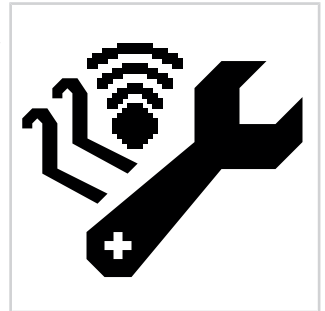

Equipment service

Blocked rear axle.



Blocked axle

**Display of remaining hours before maintenance**

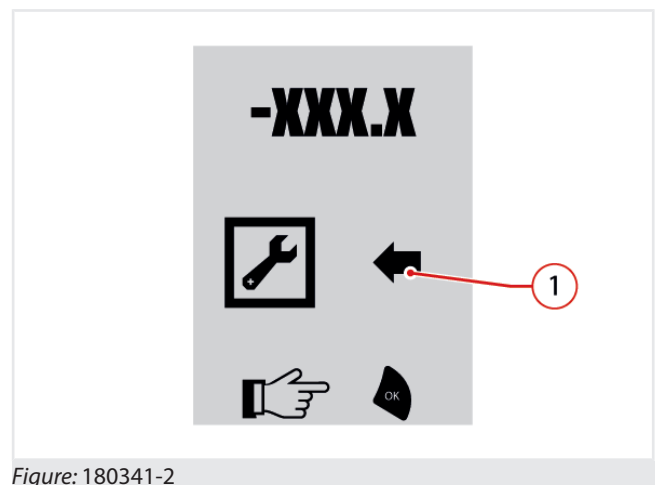

Figure: 180341-2

To find out the hours remaining to next maintenance, it is necessary to access the Service page (fig. 150434-2):

- Press the **MENU** button,
- Select the Service icon,
- Press the **OK** button.

To return to the Home screen, simply press the **MENU** button or select the **BACK** icon "1" and press the **OK** button.



## NOTE

Contact the Dieci technical service to perform maintenance and reset the Service hour counting.

### 7.3.7 - Clock

On the home screen there is the indication of the time next to the related icon (fig. 180340-1).



180340-1

#### Setting the clock

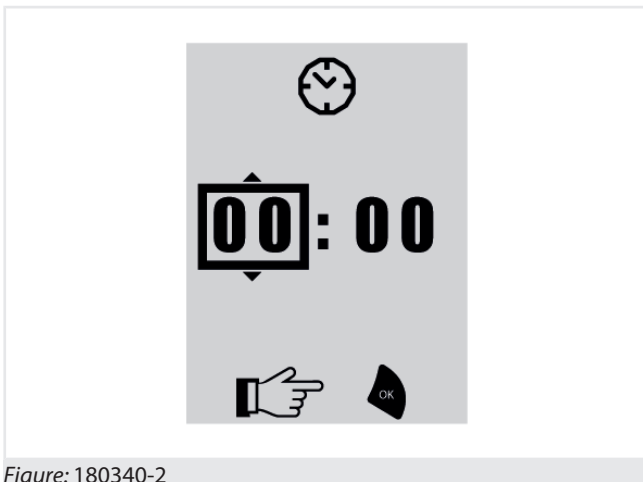

Figure: 180340-2

To adjust the time it is necessary to (fig. 180340-2):

- Press the **MENU** button,
- Select the clock setting icon,
- Press the **OK** button,
- Use the **UP** and **DOWN** to set the hour digits,
- Press the **OK** button,
- Use the **UP** and **DOWN** to set the minutes digits,
- Press the **OK** button to set the new time.

Press the **MENU** button at any time to cancel the process and return to the Home screen.

### 7.3.8 - Hour meter

On the home screen there is the indication of the hour meter next to the related icon (fig. 150440-1).



150440-1

The separation of the decimal point flashes when the hour meter is active.

### 7.3.9 - Transmission Icon

The Transmission icon indicates the mechanical gear currently in use:

Icon	Description
	<b>Hare</b> Fast gear engaged, it allows the vehicle maximum speed during the travels.
	<b>Tortoise</b> Slow gear engaged, the vehicle has more torque to the detriment of the maximum speed.

### 7.3.10 - Low Idle UP icon



A



B

"A" icon: the "LOW IDLE UP" configuration is active on the vehicle, as the Safe State condition is verified.

In this state, the engine rpm are increased in order to reduce the accumulation of unburned hydrocarbons.

"B" icon: engine control unit requires the "LOW IDLE UP" configuration; the machine should be set to Safe State mode.

The Safe State setup involves:

- Vehicle stopped;
- No boom movements;
- Parking brake on.

The icons turn off when the operator manually raises the engine rpm above the levels required for HC Removal Strategy.

### 7.3.11 - Anti-tipping device ByPass icon

The Anti-tipping Device ByPass icon is displayed when the ByPass key is used.



180351-2



180403-1

### 7.3.12 - Seat Switch icon

The icon (fig. 150443-1) lights on when the operator is not properly seated in the driver's seat.



150443-1

### 7.3.13 - Wheels alignment check icon \*



#### NOTE

\* **The Wheels alignment check icon is part of the optional attachments.**

Refer to the chapter Wheels alignment check \* [► 92].

The Wheels alignment check icon indicates when the wheels are aligned and parallel to the vehicle chassis.

Icon	Description
	Front wheels aligned
	Rear wheels aligned
	Front and rear wheels aligned

### 7.3.14 - Not connected man basket icon \*



#### NOTE

\* Not connected man basket icon is part of an optional attachment.

The not connected man basket icon (fig.180403-1) indicates the error status in which the automatic equipment recognition system detects the installation of a man basket, but the electrical connection between the basket and the vehicle has not been made.

### 7.3.15 - Levelness Icon \*



#### NOTE

The Levelness icon is present on vehicles with pre-arrangement for man basket.

The levelness icon indicates when the vehicle is in a working condition within the maximum tilting limits set by the manufacturer.

Icon	Description
A	The icon indicates that the vehicle is within the working limits and can operate normally.
B	The icon indicates that the vehicle is out of the allowed tilting limits and must be leveled in order to proceed with the work.

When working with the man basket, the pilot light "B" turns on together with an acoustic signal that can be silenced by pressing the "OK" button on the instrument panel.

It is possible to see the exact levelness values accessing the Check page [► 90].

### 7.3.16 - Hydraulic sockets on boom head icon \*



#### NOTE

\* The Hydraulic sockets on boom head icon is part of the optional attachments.

The Hydraulic sockets on boom head Icon indicates the active hydraulic socket on the boom head.

Icon	Description
<b>F0</b>	Standard active hydraulic socket
<b>F1</b>	First additional active hydraulic socket
<b>F2</b>	Second additional active hydraulic socket

### 7.3.17 - Accumulation of unburned hydrocarbons (HC) pop up \*



#### NOTE

**The accumulation of unburned hydrocarbons pop up is available only in Stage V engines**

This warning specifies the accumulation of unburned hydrocarbons (HC) inside the ATS system.

It will get activated in case of accumulation level equal or higher than 4.

The pop up is automatically displayed for 5 seconds every 60 seconds when the accumulation level is equal or higher than 4.



### 7.3.18 - FPT Stage V AdBlue quantity

The Home screen contains the AdBlue Quantity indicator (fig.180404-1).



180404-1

The AdBlue Quantity indicator is expressed as a percentage, where:

- 0% indicates the empty tank
- 100% indicates the full tank.



#### NOTE

Refer to the chapter "AdBlue®".

When the AdBlue level is below 10%, the "AD BLUE" message flashes slowly, while when it is below 5%, it flashes fast.

### 7.3.19 - Menu

From the Home screen, it is possible to access the menu (fig. 180347-1) pressing the **MENU** key.



Figure: 180347-1

Use the **UP** and **DOWN** buttons to scroll through the menu items and press the **OK** button to make a selection and go to the related page.

The menu items are:

	Clock [▶ 86]
	Active errors [▶ 89]
	Check page [▶ 90]
	Service [▶ 85]
	Anti-tipping calibration (Reserved to qualified personnel)
	Info page [▶ 88]
	Equipment Info page * [▶ 90] (only if the Equipment recognition attachment is present)

### 7.3.20 - Info page

The Info page provides information about the software version installed on the vehicle.



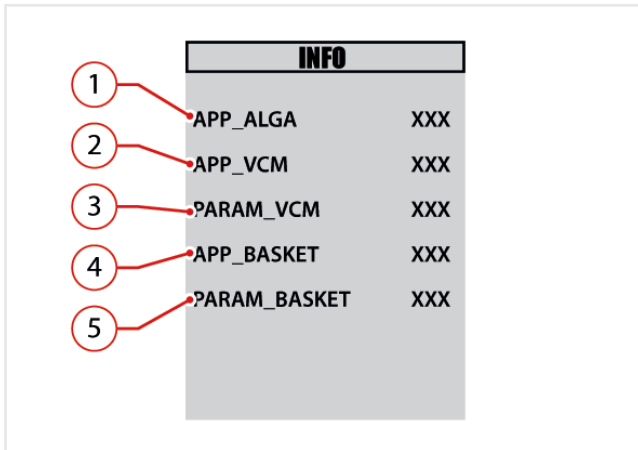

Figure: 180350-1

1	Software version
2	VCM software version
3	VCM parameter version
4	Man basket control unit software version
5	Basket control unit parameter version

To access the Check screen it is necessary to:

- Press the **MENU** button,
- Select the Info icon,
- Press the **OK** button.

To return to the Home screen, simply press the **MENU** button or select the **BACK** icon and press the **OK** button.

### 7.3.21 - Active errors

The presence of errors will be reported by the general warning icon, by the acoustic signal lasting 1.5 sec. and by the displaying of the error code on the Home screen instead of the time.



150432-1

In the presence of more than one error, the error codes will be displayed cyclically every 2 sec. on the Home screen. At the end of the cycle showing all the active errors, an icon will be displayed that indicates the user to access the Active Errors page to view all active errors in that time.

In case of an error from the SAR, the acoustic signal will be continuous and the error code will remain fixed on the Home screen. Press the **OK** button to stop the sound of the acoustic signal and resume the active errors displaying cycle.

Active errors displaying

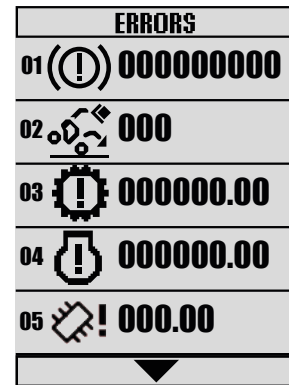

Figure: Active errors

To enter the Active errors page it is necessary to:

- Press the **MENU** button,
- Select the Active errors icon,
- Press the **OK** button,

Use the **UP** and **DOWN** buttons to scroll though the pages if there are several errors. The arrows at the bottom of page "1" indicate the presence and directions in which the additional pages flow.

Press the **MENU** button at any time to return to the Home screen.

Each error code is associated with an icon that identifies the nature of the error:

Icon	Example	Description
	000000000	Parking brakes errors or brakes failure
	000	SAR errors ALGA errors
	000000.00	Transmission errors
	000000.00	Engine errors
	00.00	Vehicle control unit (VCM) errors
	000000.00	Post treatment errors
	0000.00	Fuse state
	000.00	Basket (BCM) errors

### 7.3.22 - Check page

The Check page is used to view the vehicle input and output parameters. This page can be consulted to provide additional information on the behavior of the vehicle in case of faults or malfunctions.

To access the Check screen it is necessary to:

- Press the **MENU** button,
- Select the Check icon,
- Press the **OK** button.

Press the **OK** button to scroll through the pages.

To return to the Home screen, simply press the **MENU** button.

### 7.3.23 - Equipment Info page \*



#### NOTE

\* The equipment info page is an optional equipment.

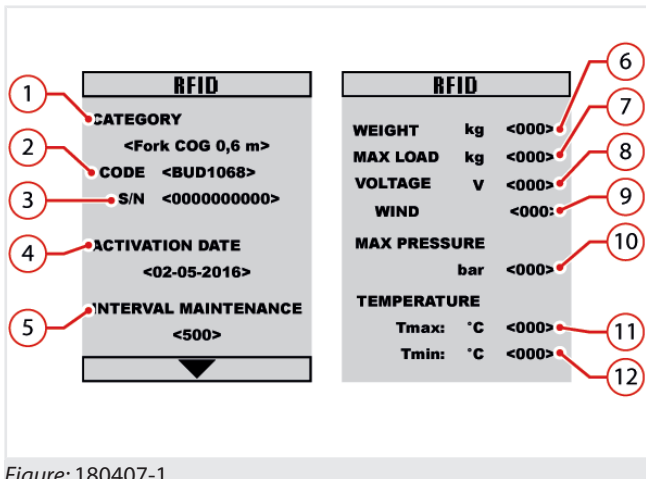

Figure: 180407-1

1	<b>Category</b>	Category name.
2	<b>Code</b>	Equipment code.
3	<b>Serial number</b>	Serial number of the equipment
4	<b>Activation date</b>	Date of first use of the equipment.
5	<b>Maintenance interval</b>	Time interval for ordinary maintenance on the equipment.
6	<b>Weight</b>	Equipment weight in kg.

7	<b>Maximum capacity</b>	Maximum equipment capacity in kg (if present).
8	<b>Electric voltage</b>	Electric voltage for using the V equipment (if present).
9	<b>Wind force</b>	Maximum wind force for using the equipment in m/s (if present).
10	<b>Maximum pressure</b>	Maximum hydraulic working pressure of the equipment in bar (if present).
11	<b>Maximum temperature</b>	Maximum operating temperature of the equipment in °C.
12	<b>Minimum temperature</b>	Minimum operating temperature of the equipment in °C.

To access the Equipment Info Page screen:

- Press the **MENU** button,
- Select the Equipment Info icon,
- Press the **OK** button.

Press the **UP** and **DOWN** keys to scroll through the pages.

To return to the Home screen, simply press the **MENU** button.

## 7.4 - Electrical steering selector

The steering selector (fig. 150312-1) is used to change the wheels steering mode.

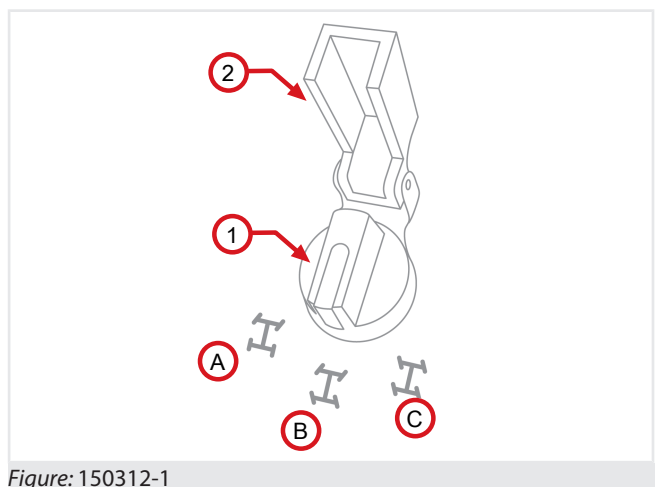

Figure: 150312-1

To select a steering mode, turn the knob "1" that indicates the corresponding symbol:

**A - Front-steering wheels**

This type of steering allows to carry out a steering with only the 2 front wheels.

**B - Four-steering wheels**

This type of steering allows to carry out the steering with all 4 wheels, so as to have the smallest turning radius possible.

**C - Transverse**

This type of steering allows a transverse or crab steering, so as to have a lateral displacement of the vehicle.



**DANGER**

**Make the steering selection only with the vehicle stopped.**

Before selecting a new type of steering, align the wheels with stopped vehicle.



**WARNING**

When the transverse steering is selected, always operate at low speed.



**ATTENTION**

For road travel is mandatory to select the 2-wheel steering mode and lock the selector with the dedicated fastener "2".

Manual wheel alignment



**ATTENTION**

Perform the wheel alignment periodically (every 8-10 hours) depending on the continuous use of the vehicle.

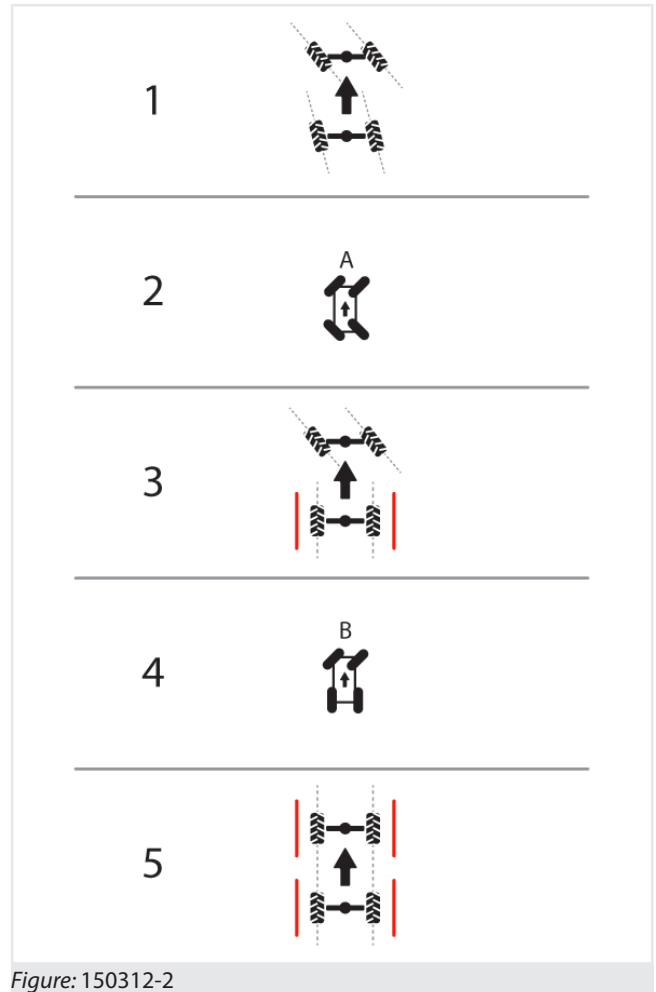

Figure: 150312-2

During normal use of the vehicle, frequently changing the steering modes, it is possible that the wheels are no longer perfectly aligned with each other.

To perform a proper wheel alignment, perform the following steps:

1. Stop the vehicle on a level ground.
2. Select the **B** or **C** steering mode
3. Turn the steering wheel until the rear wheels are aligned to the vehicle.
4. Select the **A** steering mode
5. Turn the steering wheel until the front wheels are aligned to the vehicle.
6. Try to move slowly for a few meters to verify that the vehicle travels properly in a straight line.

**If at the end of the alignment the vehicle still does not proceed in a straight line, repeat the wheels alignment**

## 7.5 - Wheels alignment check \*



### NOTE

\* The wheels alignment check is an optional accessory.



### ATTENTION

Perform the wheel alignment periodically (every 8-10 hours) depending on the continuous use of the vehicle.

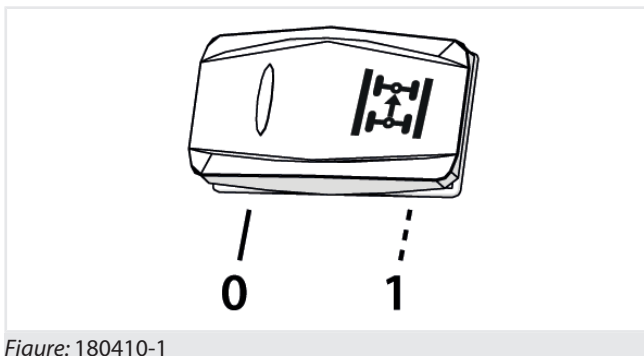

Figure: 180410-1

During normal use of the vehicle, frequently changing the steering modes, it is possible that the wheels are no longer perfectly aligned with each other. The automatic wheels alignment allows to quickly and accurately align the wheels.

To align the wheels using the automatic wheel alignment, it is necessary to (fig. 180410-1):

Stop the vehicle on a level ground.

In case two of the four wheels are very misaligned, try to align them manually (see chapter "Electric steering selector") as much as possible.

For automatic alignment turn the wheels slowly, this will make the alignment more precise.

Select the 4-wheel or transverse steering mode.

Press the button.

Once the button is pressed, the Rear wheels alignment light will be red.



Turn the steering wheel slowly to align the rear wheels with the vehicle, until the Rear wheels alignment light turns green, then it will automatically switch to front steering mode.

The front steering mode will activate automatically and this will be indicated by the red light.



Turn the steering wheel slowly to align the front wheels with the vehicle until the Front wheels alignment light turns green.

The wheel alignment is now completed, as confirmed by the indicator light displayed for 3 seconds and by the steering wheel return to the mode originally selected.



## 7.6 - Boom control

### 7.6.1 - Joystick

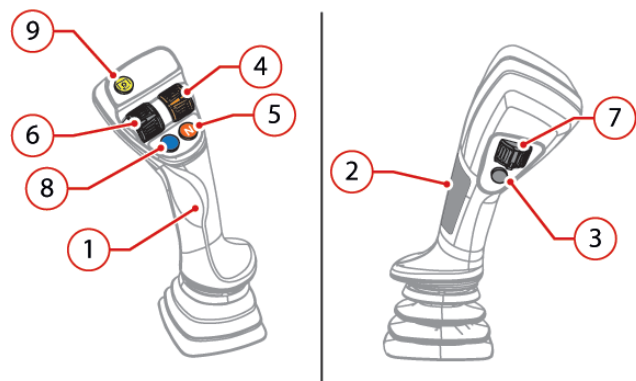

Figure: 171225-1: Joystick description

1 Grip	2 Deadman sensor
3 Deadman button	4 FNR roller
5 Neutral button	6 Extension roller
7 Services roller	8 Hydraulic sockets change button *
9 Continuous oil function button	

\* Components depending on optional equipment or pre-arrangements.

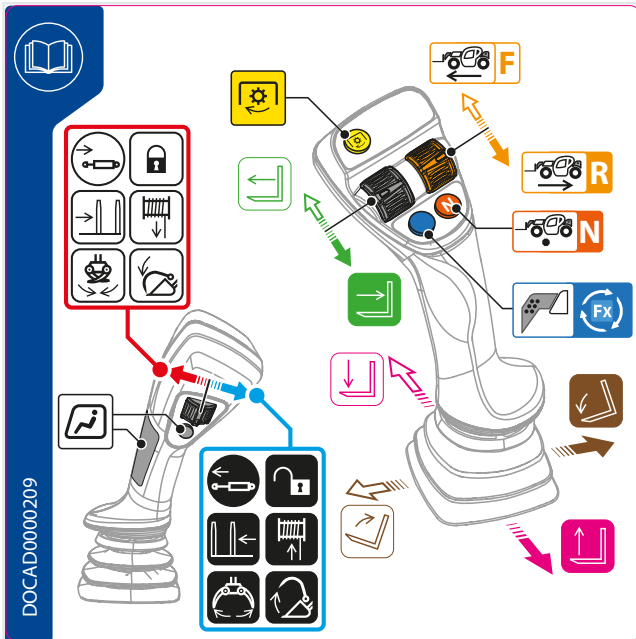

Figure: 180301-1: Instructions for using the joystick

**7.6.1.1 - Grip**

	Description
	Boom lifting: Move the joystick handle backwards.
	Boom lower: Move the joystick handle forward.
	Tilting downwards: Move the joystick handle to the right.
	Tilting upwards: Move the joystick handle to the left.

**7.6.1.2 - FNR roller**

	Description
	Forward gear (F) Refer to FNR commands on joystick
	Neutral (N) Refer to FNR commands on joystick
	Reverse (R) Refer to FNR commands on joystick

**7.6.1.3 - Extension roller**

	Description
	Boom retraction: Move the extension roller backwards.
	Boom extension: Move the extension roller forward.

**7.6.1.4 - Services roller**



**NOTE**

**It is possible to connect different equipment and tools with different applications to the hydraulic sockets dedicated to the services.**

Refer to the equipment or tool manual to know its correct operation and its controls.

	Description
	Cylinder extension: Move the services roller to the right.
	Block opening: Move the services roller to the right.
	Shifting to the right: Move the services roller to the right.
	Winch rope descent Move the services roller to the right.
	Grippers closing: Move the services roller to the right.
	Bucket closing: Move the services roller to the right.

	Description
	Cylinder extension: Move the services roller to the left.
	Block opening: Move the services roller to the left.
	Shifting to the left: Move the services roller to the left.
	Winch rope lifting: Move the services roller to the left.

	Description
	Grippers opening: Move the services roller to the left.
	Bucket opening: Move the services roller to the left.

### 7.6.1.5 - Deadman function: Capacitive sensor

	Description
	The deadman joystick function prevents any accidental movements.

The Joystick features a "deadman" capacitive sensor: to enable it to function you need to place your hand on the grip "1" (fig.171225-1), correctly so as to activate the capacitive sensor "2".

If your hand is not resting on the capacitive sensor "2", boom movements are disabled.

Adjust the seat and the armrest so you can hold the joystick correctly (fig. 150450-2).

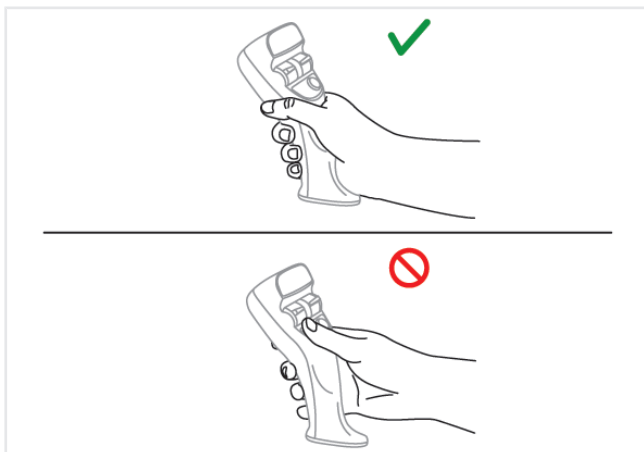

Figure: 150450-2

### 7.6.1.6 - Deadman function: Button

	Description
	The deadman joystick function prevents any accidental movements.

To enable the joystick controls it is necessary to keep the deadman button "3" pressed (fig. 171225-1).

The deadman function use by means of a button or by a capacitive sensor of the handle are the same.

### 7.6.1.7 - Continuous oil function for sockets on boom head \*

	Description
	Continuous oil function.

The continuous oil function allows to maintain a constant volume of oil passing through the hydraulic sockets without acting consistently on the selector of the joystick.



#### ATTENTION

**With the continuous oil function enabled, do not move away from the vehicle.**

Always stay within reach of the emergency stop button to stop all vehicle movements in an emergency.



#### NOTE

With the continuous oil function active it is still possible to use the joystick to move the boom.

When light of button "9" is on, on the joystick, it indicates that the continuous oil function is active.

With the continuous oil function active, the selection of the hydraulic sockets [if present] is disabled.

### Activation of continuous oil function with vehicle in motion

Perform this procedure in case of work that requires the operator sitting in the cab and vehicle in motion.

**To activate the function it is necessary to (fig. 180301-1):**

- The operator must be seated correctly in the driver's seat,
- Hold the joystick "1",
- [If there are several optional hydraulic sockets] Select the desired hydraulic socket on which to activate the function,
- Use the services roller on the joystick "7" to set the desired flow of oil.
- Maintain the flow of oil through the services roller and simultaneously press the button "9" for at least 3 seconds to activate the continuous oil function.

**To disable the function it is necessary to:**

- Press the button "9".

The continuous oil function stops if the operator rises from the seat.

**Activation of the continuous oil function with stationary vehicle**

Carry out this procedure in case of work requiring stationary vehicle and operator near the vehicle but not sitting in the cab.

**To activate the function it is necessary to (fig. 180301-1):**

- The vehicle must be stationary and with parking brake engaged.
- The operator must NOT be seated correctly in the driver's seat,
- Hold the joystick "1",
- [If there are several optional hydraulic sockets] Select the desired hydraulic socket on which to activate the function,
- Use the services roller on the joystick "7" to set the desired flow of oil.
- Maintain the flow of oil through the services roller and simultaneously press the button "9" for at least 3 seconds to activate the continuous oil function.

When light of button "9" is on, on the joystick, it indicates that the continuous oil function is active.

With the continuous oil function active, the selection of the hydraulic sockets [if present] is disabled.

**To disable the function it is necessary to:**

- Press the button "9".

**7.6.1.8 - Selection of hydraulic sockets on the boom head \***

Description	
	Selection of hydraulic sockets on the boom head



**NOTE**

\* The function of selecting hydraulic sockets on the boom head is an optional attachment. The presence and number of hydraulic sockets and electrical contacts present on the boom head may vary depending on optional attachments.



**DANGER**

**Danger of moving the wrong hydraulic socket.**

Do not operate the hydraulic sockets using the joystick during the selection of the hydraulic socket. Make the selection of the hydraulic socket and use the joystick to control the hydraulic socket selected only at a later time.

After connecting the equipment to the hydraulic sockets before starting the job, check in a safe location that all the controls are working properly. During the test, be careful not to create danger or damage to persons, animals or things.

The hydraulic socket selection function is used to change the active hydraulic socket on the boom head.

Hold the joystick "1" (Fig. 171225-1) and press the Hydraulic socket change button "8". The active hydraulic socket on the head boom will switch to the next available hydraulic socket in a cyclic manner.

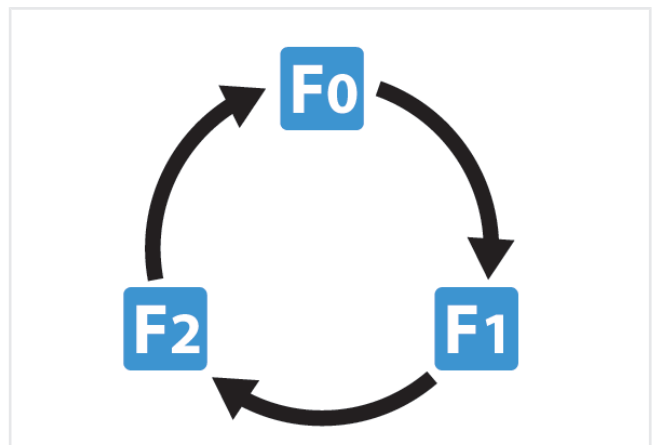

Figure: 180310-1: Hydraulic sockets selection cycle

The icon corresponding to the active hydraulic socket will be shown on the display.

Switching the vehicle off and on again, the active hydraulic socket will always be the default one (F0) and not the last one previously selected.

**7.6.2 - Boom suspension \***



**NOTE**

\* The boom suspension is an optional accessory.

The switch boom suspension has a safety lock to prevent accidental activation.

To activate the boom suspension, move the block and simultaneously press the switch (fig. 150310-1).

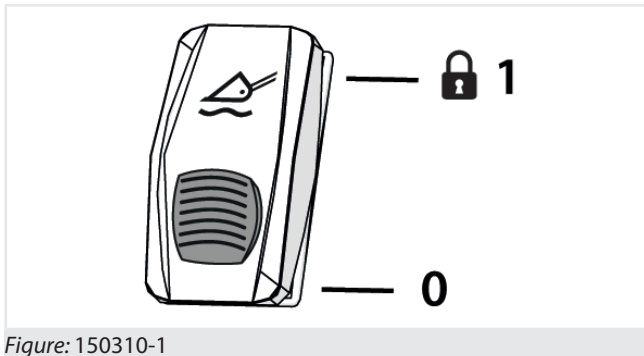

Figure: 150310-1

The indicator light on the display indicates that the function is active.



## WARNING

### The boom suspension works only if:

- Boom is down;
- Button is pressed;
- Vehicle speed is higher than 5 km/h

The boom suspension is automatically deactivated when the "dead man" function is activated on the joystick.

The suspension may also be used during the transport of loads, with the boom in transport position (fully retracted and in horizontal position).



## WARNING

### Activating the boom suspension, the boom may have a slight but sudden upward movement.

Before activating the boom suspension, make sure that the installed equipment and any load are properly secured to the vehicle and that there are no people, animals or objects within the operating range of the vehicle.



## ATTENTION

The presence of the boom suspension does not involve the increase of the transport speed and vehicle movement. The speed must always be proportional to the ground, to the place of use and to the atmospheric conditions.



## NOTE

The boom suspension is a device which entails an increase in the comfort of the vehicle, but it does not increase its safety characteristics.

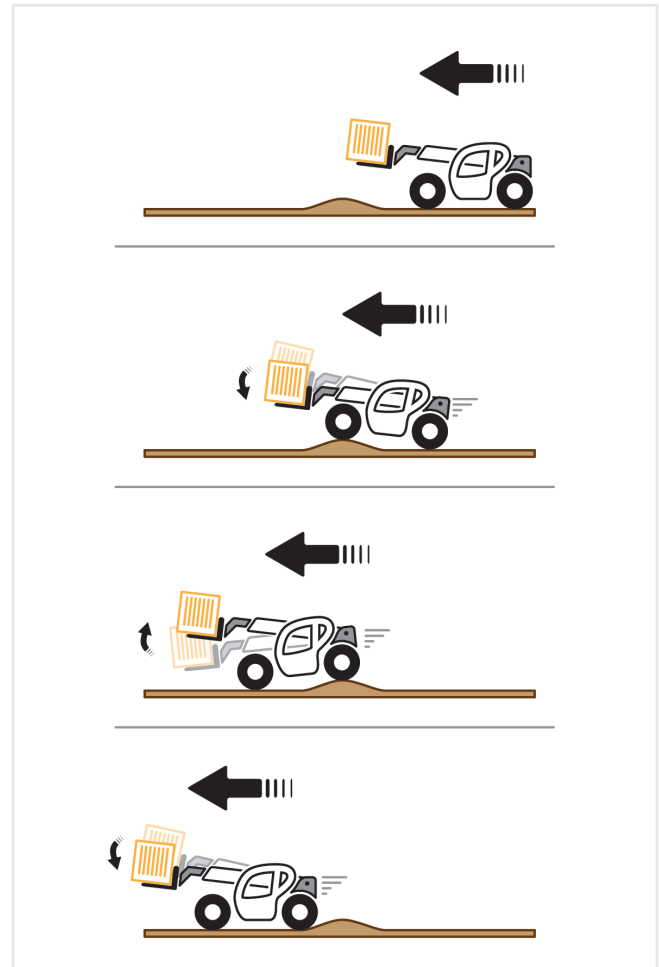

Figure: 150310-2

## 7.6.3 - Quick coupling \*



## NOTE

\* The equipment quick coupling is an optional attachment.

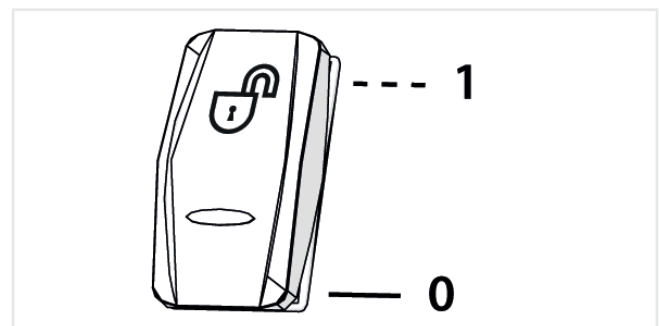

Figure: 171228-1

The equipment quick coupling allows the operator to install and fasten the equipment to the attachment holding plate directly from the cab.



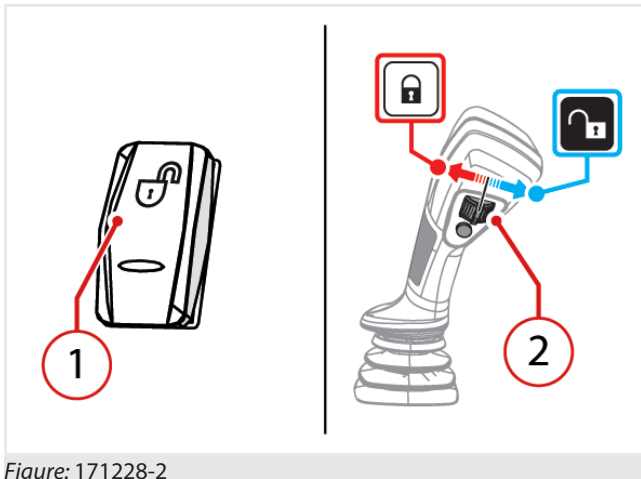

Figure: 171228-2

To use the quick coupling to install the equipment it is necessary to (fig. 171228-2):

- Carry out the normal hooking operations set out in paragraphs 1, 2, 3 and 4 of the chapter "Equipment installation".
- Press the Quick Coupling button "1" and at the same time operate the roller on the services joystick "2" to open the quick coupling.
- Keep the quick coupling open, tilt the plate upward to make sure that the equipment is fully resting on the attachment holding plate.
- Release the roller on the services joystick "2" and the Quick coupling button "1" to close the quick coupling and lock the equipment.
- If the equipment is not properly fastened, repeat the installation.



**DANGER**

**Danger of load, equipment or tool falling.**

Do not operate without having first properly fastened the equipment to the plate.

**7.7 - Hydraulic sockets and electrical contact on boom head \***



**NOTE**

\* The presence and number of hydraulic sockets and electrical contacts present on the boom head may vary depending on optional equipment.

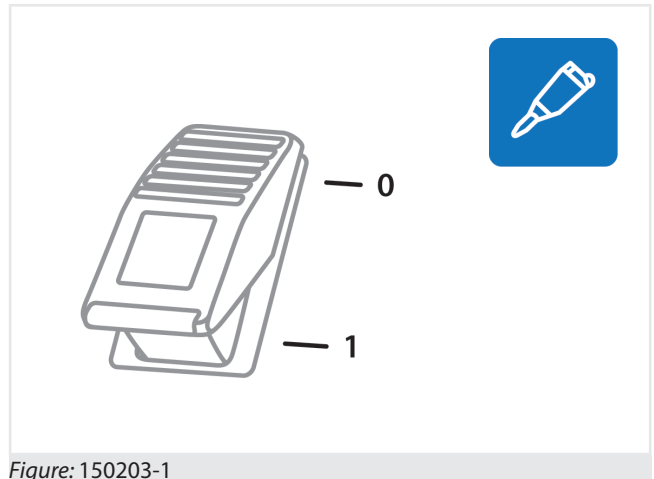

Figure: 150203-1

The sockets switch on the boom head (fig. 150203-1) has several functions and positions depending on the optional attachments installed on the vehicle.

Once selected the desired hydraulic socket, it is necessary to use the services lever on the joystick to operate the desired movement.



**DANGER**

**Danger of moving the wrong hydraulic socket.**

Do not operate the hydraulic sockets using the joystick during the selection of the hydraulic socket. Make the selection of the hydraulic socket and use the joystick to control the hydraulic socket selected only at a later time.

After connecting the equipment to the hydraulic sockets before starting the job, check in a safe location that all the controls are working properly. During the test, be careful not to create danger or damage to persons, animals or things.



**WARNING**

Pay attention to the connections of the hydraulic socket: moving the service lever placed on the joystick forward, towards the open padlock (see Joystick chapter) oil will be sent to the sockets marked with the color **BLUE** or by the symbol "+".

Attachments	Diagram	Switch description
<b>Standard hydraulic socket</b>		0 - Electrical contact off
<b>+ Electrical contact</b>		1 - Electrical contact on
<b>Standard hydraulic socket</b>		0 - Standard hydraulic socket
<b>+ Additional hydraulic socket</b>		1 - Electrical contact on

Attachments	Diagram	Switch description
+ <b>Electrical contact</b>		2 - Additional hydraulic socket

## 7.8 - Electrical contact on boom head \*



### NOTE

\* The electrical contact on the boom head is an optional accessory.

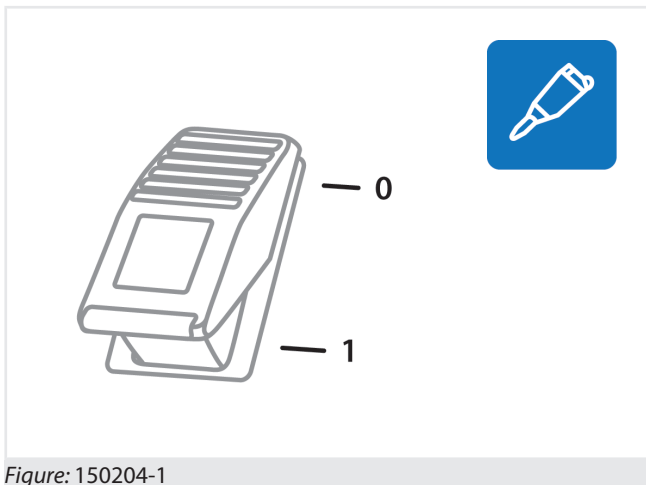

Figure: 150204-1

At the socket of the electric contact on the telescopic boom head (fig. 150204-1) it is possible to connect:

- The plug of the solenoid valve of the Second Additional hydraulic socket
- The plug of any equipment installed on the attachment holding plate.

To activate the electric contact, place the Sockets switch on the boom head in position "1" - See table in the previous chapter.



### NOTE

For information on how to make the connections to the electrical socket, refer to the "Electrical connections" chapter.



### WARNING

**Do not connect users with nominal voltage greater than 12 V and amperage greater than 3 A.**

Risk of damage to the electrical system.

## 7.9 - Plate translation unit\*



### NOTE

\* The plate translation unit is an optional accessory.

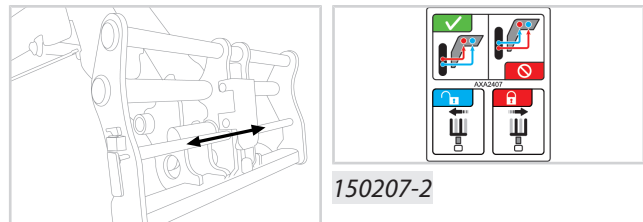

150207-1

The plate shifting unit (fig. 150207-1) allows the attachment holding plate and related equipment installed, to make small lateral movements.

To use the plate shifting unit, one of the two operations must be carried out (depending on the other options installed on the vehicle):

- Select the sockets on the boom head to which the Plate shifting unit is connected through the button marked with the symbol (Fig. 150207-3),



150207-3

With the boom head socket active, use the services roller on the joystick to move the plate to the right or left. Refer to the instructions shown in the figure (fig. 150207-2) and the "Joystick" chapter.



### WARNING

Before starting to work, make some test movements in an area free of people or things.

## 7.10 - Equipment quick coupling \*



### NOTE

\* The equipment quick coupling is an optional accessory.

The equipment quick coupling allows the operator to install and fasten the equipment to the attachment holding plate directly from the cab.

There are different models of quick couplings for equipment, they can be with a single block cylinder lock or double block cylinder, the procedures for use change according to the type of hydraulic system of the vehicle.

**7.10.1 - Quick coupling with single lock on open circuit vehicle**

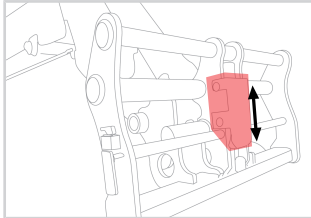

150206-4

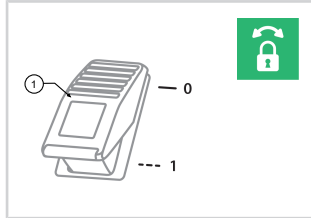

150206-5

To use the quick coupling (fig. 150206-4) for the equipment installation it is necessary to:

- Carry out the normal hooking operations set out in paragraphs 1, 2, 3 and 4 of the chapter "Equipment installation procedure".
- Press the Quick Coupling button "1" (fig. 150206-5) and at the same time operate the roller on the services joystick to open the quick coupling.
- Keep the quick coupling open, tilt the plate upward to make sure that the equipment is fully resting on the attachment holding plate.
- Release the roller on the services joystick and the Quick coupling button "1" to close the quick coupling and lock the equipment.
- If the equipment is not properly fastened, repeat the installation.



**DANGER**

Do not operate without having properly secured the equipment to the plate, danger of load and equipment falling.

To use the quick coupling (fig. 150206-7) for the equipment installation it is necessary to:

- Carry out the normal hooking operations set out in paragraphs 1, 2, 3 and 4 of the chapter "Equipment installation procedure".
- Press the Quick Coupling button "1" (fig. 150206-8) and at the same time operate the roller on the services joystick to open the quick coupling.
- Keep the quick coupling open, tilt the plate upward to make sure that the equipment is fully resting on the attachment holding plate.
- Release the roller on the services joystick and the Quick coupling button "1" to close the quick coupling and lock the equipment.
- If the equipment is not properly fastened, repeat the installation.



**DANGER**

Do not operate without having properly secured the equipment to the plate, danger of load and equipment falling.

**7.10.2 - Quick coupling with double cylinder**

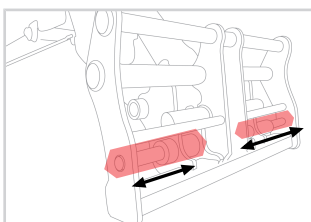

150206-7

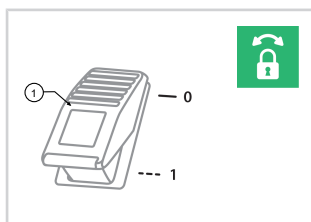

150206-8

**7.11 - Safety rod**

The safety rod must be used as a safety measure during maintenance operations, to prevent the descent or fall of the boom in case of failures.

To insert the safety rod "1" (fig. 150459-1) operate as follows:

- Lay a load on the ground
- Completely close the extensions of the telescopic boom
- Lift the boom to the minimum height necessary to apply the safety rod
- Apply the safety rod around the lifting cylinder rod

Lock the safety rod by means of the appropriate hooks "2".

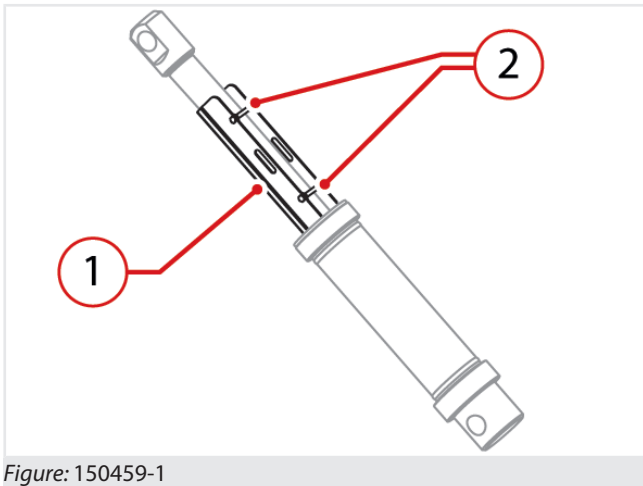

Figure: 150459-1



## WARNING

### DANGER OF CRUSHING

In case of maintenance to the boom lifting cylinder or the relative block valve it is required to support the boom by means of an appropriate lifting device with minimum capacity of at least 3000 kg (6613.87 lb).

## 7.12 - Wheel wedge

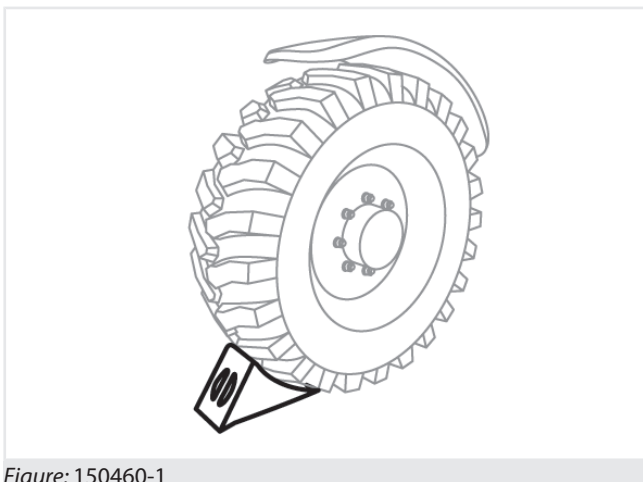

Figure: 150460-1

The wheel wedge (fig. 150460-1) must be used as a safety measure to prevent accidental or unwanted movements of the vehicle.

It is advisable to use them when parking the vehicle during stops along slopes or during maintenance operations.

## 7.13 - Block valves

The block valves (fig. 150461-1) for cylinders prevent uncontrolled movement of the pistons of the cylinders in the event of hydraulic pressure failure or bursting of a flexible pipe.

The valves are installed directly on all the cylinders.

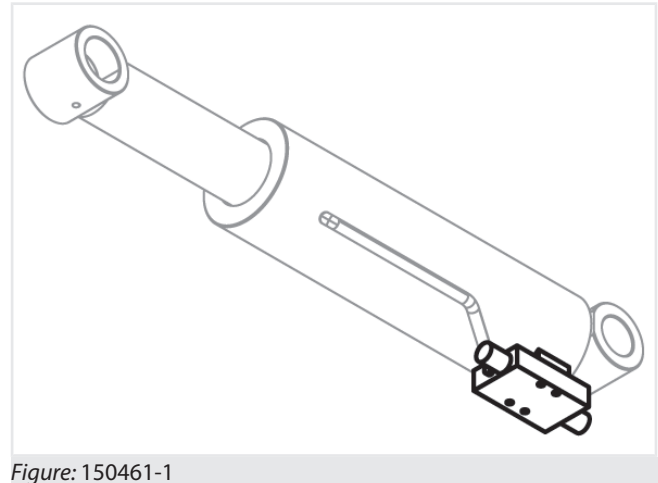

Figure: 150461-1

## 7.14 - Diagrams notebook

The diagrams notebook (fig. 150462-1) summarizes the main information for safe use of the vehicle for easy reference by the operator during the various processing phases.

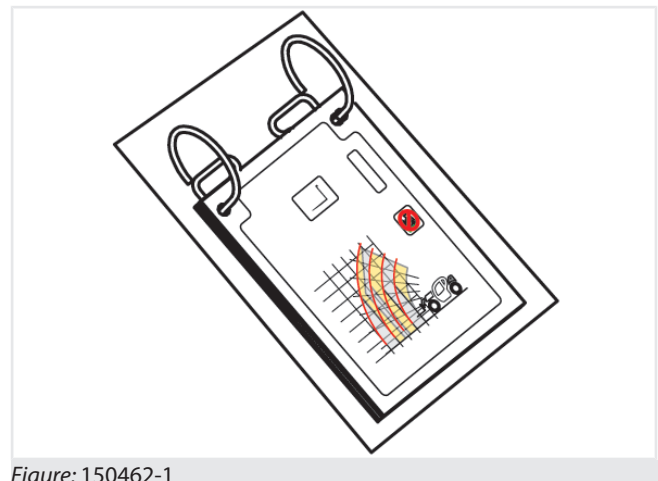

Figure: 150462-1

### 7.14.1 - Load Charts

The Safe Working Load (SWL) of the vehicles depends on the extension extent and the boom angle.

The load charts show the maximum height and extent allowed by certain equipment and loads, in order to work safely, without the risk of tipping of the vehicle during work operations.

This vehicle is however equipped with an anti-tipping device that monitors in real time the status of the load and the risk of tipping of the vehicle (see the "Anti-tipping device" chapter in the vehicle manual). It is however necessary to use and adhere to the load charts in relation to the load and type of accessory used.



**ATTENTION**

It is mandatory to have in the cab, the load chart referred to the equipment and the vehicle that is being used.

Refer to the correct load chart before handling a load.



**DANGER**

**Danger of tipping.**

Do not raise or extend the boom when the vehicle is in motion. Fully lower and retract the boom before moving a load.



**ATTENTION**

The load charts refer to stopped and leveled vehicle.



**ATTENTION**

The diagrams of the vehicle and equipment being used must always be present in the Diagram notebook found in the cab, used by the operator.

Replace the load charts if they deteriorate, are damaged or lost.

The load charts are ordered just like spare parts (make sure you provide the relative identification code when placing the order).

Before handling a load it is necessary to:

- Have read and understood the use and maintenance manual of the vehicle and equipment.
- It is mandatory to know the weight of the load that must be handled.
- Locate the center of gravity of the load to be moved. The center of gravity may not be at the center of the load.

7.14.1.1 - Read the load charts

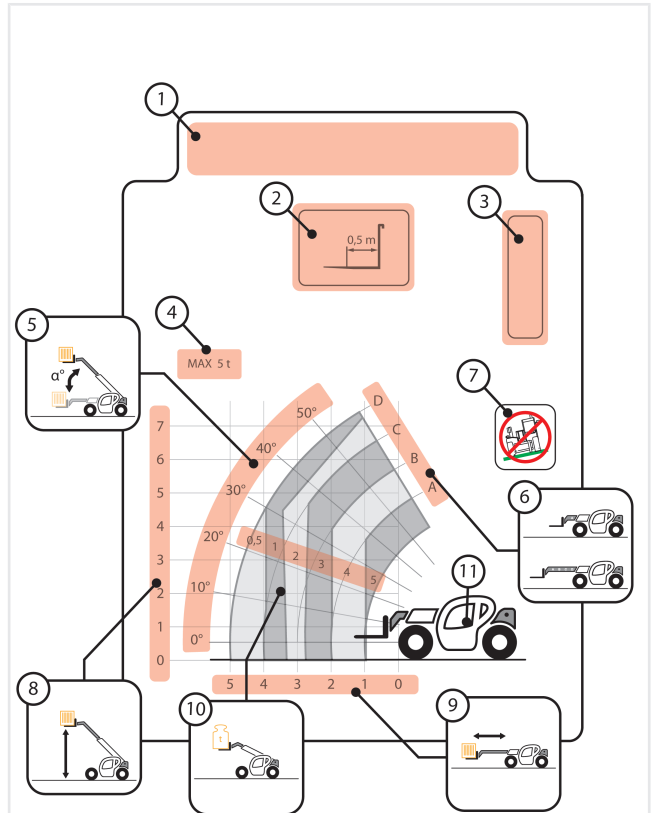

Figure: 150464-1 - Load Chart

1	<b>Vehicle name and model</b>
2	<b>Equipment model</b> Equipment model with the indications of center of the load. For more information, see the Equipment legend for load charts [ 103] chapter.
3	<b>Load Chart code</b>
4	<b>Equipment maximum capacity</b> The maximum Capacity of the equipment is also reported by the sticker placed on the equipment itself.
5	<b>Boom angle</b> The boom angle is indicated by the inclinometer on the left side at the end of the boom (if any), or on the display of the anti-tipping device (if present).
6	<b>Boom extension</b> The boom extension is indicated by letters of the alphabet ("A", "B", "C", "D", etc...). The same letters are shown as stickers on the boom extension, so that the user in the cab can know the boom extension by reading the letters on it.
7	<b>Vehicle operating mode</b> For more information, see the Operating modes legend for load charts [▶ 103] chapter.
8	<b>Load height from ground</b>

9	<b>Horizontal distance of the vehicle load</b>
10	<b>Load weight</b>
11	<b>Vehicle position</b>

### 7.14.1.2 - Use the load charts

The Load charts indicate the areas in which it is possible to operate with the vehicle and load in safe conditions.



## DANGER



### Danger of tipping.

Operating the vehicle without observing the Load charts related to the equipment installed may result in hazardous conditions, up to the tipping limit and the operation of the Anti-tipping device.

The whole working area of the boom is divided into these areas (position "1", fig. 150465-1). Each area corresponds to a maximum capacity. The area closest to the vehicle will have a capacity equal to the maximum loading capacity of the vehicle; as moving away from the vehicle, the maximum capacity of the areas decreases.

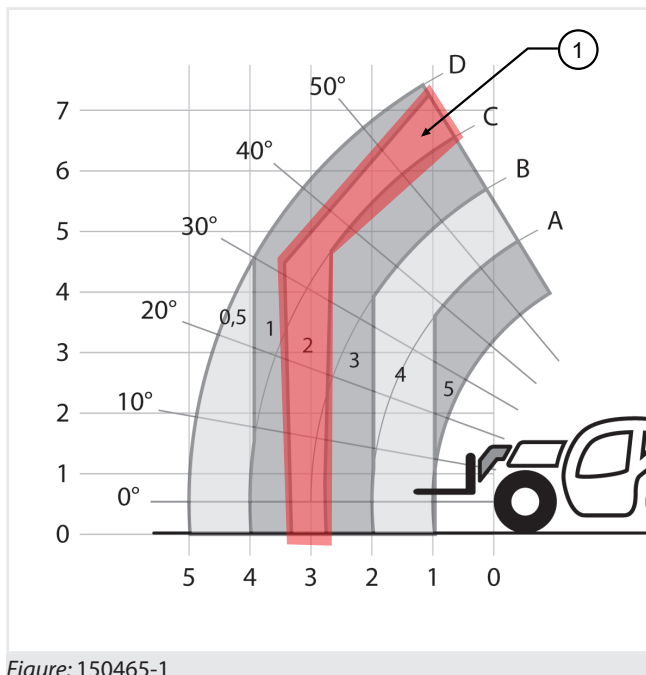

Figure: 150465-1

Before starting to work, it is necessary to know:

- Load weight
- Height from ground at which the load must be handled
- Distance from the vehicle at which the load must be handled

Locate the area of the load charts, showing a value just above the weight of the load to be handled; for example if the load should weigh 1.5 tons, the area to which it is necessary to refer is the area with a capacity of 2 tons (position "1").

Knowing the area, the following will be known:

- the vertical and horizontal distance to which it will be possible to handle the load
- the boom extension and angle values at which it is possible to operate.

In order to know the vertical and horizontal distance to which it will be possible to handle the load, use the horizontal and vertical lines that cross the reference area; for example, it will be possible to carry the load at a distance of 3 m from the vehicle and 4 m in height remaining in safety conditions (position "2", fig. 150465-2).

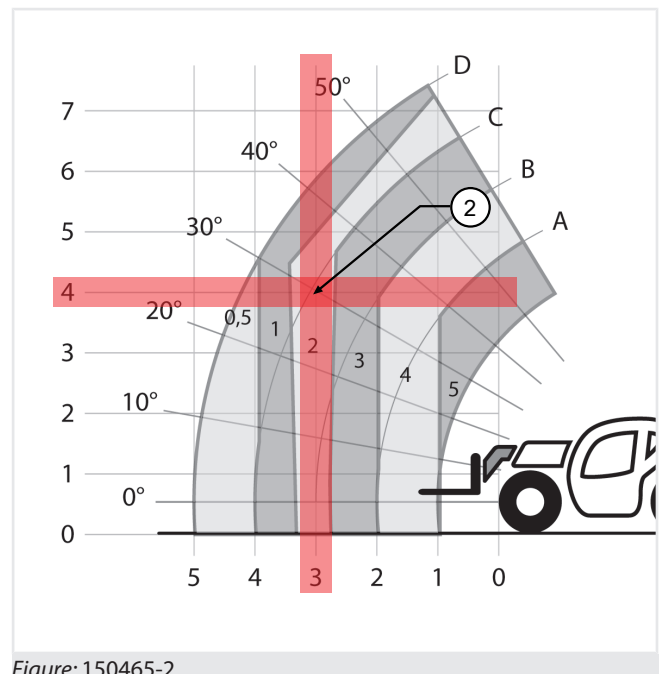

Figure: 150465-2

To avoid operating in conditions of tipping danger, use the boom angle and extension indications. For example, we could operate with the boom extended to letter C at an angle of 30° (position "3", fig. 150465-3).

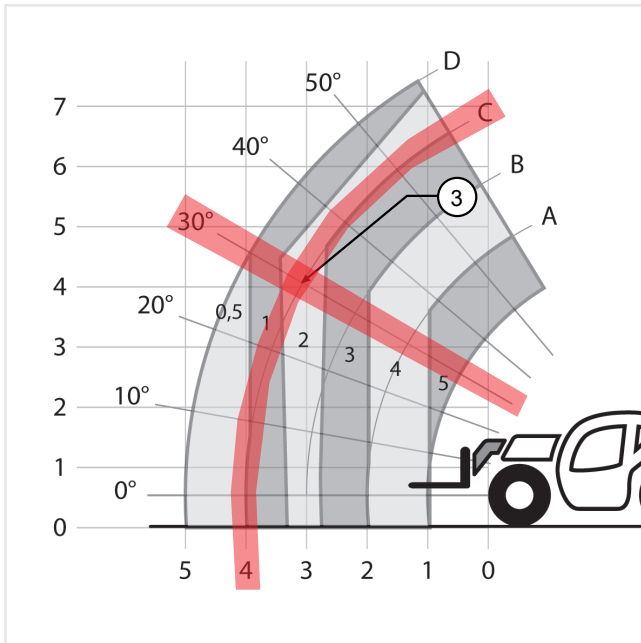

Figure: 150465-3



**DANGER**



**Taking the load beyond the permissible area, we would enter in danger conditions of tipping over and the anti-tipping device, locking all the movements considered aggravating to the stability of the vehicle and of the load.**

Use the load charts for each load handling to determine the working area.

It is possible to start operating only under safety conditions and if within the predetermined safe work area.

**7.14.1.3 - Equipment legend for load charts**

	Forks xxx = Center of gravity of the load
	Forks Spreader / Shifter xxx = Center of gravity of the load
	Winch xxx = Capacity
	Crane extension xxx = Center of gravity of the load
	"Gooseneck" jib (Dimensions) xxx = Center of gravity of the load

	Hook for fork carrier plate
	Gripper for pipe with pipe locker xxx = Center of gravity of the load
	Cylinders manipulating gripper
	Wheels manipulating gripper
	Sheets holding gripper
	5 teeth orange-peel grabber
	Centering layer
	Negative jib
	Positive jib
	Fixed front basket xxx = length, yyy = width
	Extensible front basket xxx = length, yyy = width, zzz = maximum width
	Fixed trilateral basket xxx = length, yyy = width
	Extensible trilateral basket xxx = length, yyy = width, zzz = maximum width
	Front basket for tunnels xxx = length, yyy = width
	Fixed trilateral basket for tunnels xxx = length, yyy = width

**7.14.1.4 - Operating modes legend for load charts**

	Prohibited to work on tires
--	-----------------------------

	Prohibition of operating with unlevelled vehicle
	Crossbeam outriggers lowered, 0% extended
	Crossbeam outriggers lowered, 50% extended
	Crossbeam outriggers lowered, 100% extended
	Crossbeam outriggers lifted
	Flap down outriggers lifted
	Flap down outriggers lowered
	On wheels
	Front position
	In non-continuous Rotation
	In continuous Rotation

## 7.15 - Water heater \*



### NOTE

The Water heater is an optional accessory.

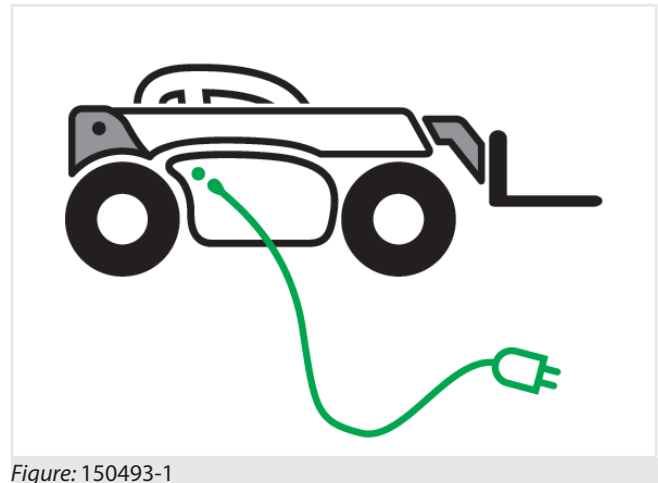

Figure: 150493-1

The water heater is connected to its own control unit and is used to facilitate the ignition of the engine in the winter period or in case of cold climates.

The water heater is placed in the rear side of the bonnet.

To use the water heater it is necessary to:

- Make sure the vehicle is off.
- Enter the extension in the socket at the rear of the hood.
- Enter the extension in the **220 V** socket.
- Wait until the water is adequately heated.
- Remove the water heater extension from the socket and from the socket on the bonnet.



### DANGER

Do not use the water heater with the engine running or the vehicle in travel.



### WARNING

**Remove the water heater power connections before turning on and/or moving the vehicle.**

Check the good condition of the power cable before starting up the device.



### NOTE

In case of malfunction contact the *Dieci* service center.



## 7.16 - Transmission

### 7.16.1 - Movement selection lever \*



#### NOTE

**The movement selection levers are optional attachments.**

The FNR movement levers can be one of two types:

- Stable control lever.
- Unstable control lever.

#### Stable control lever



#### ATTENTION

In order to select a direction of movement, it is necessary to move the movement selection lever towards the steering wheel. This shifting protects the lever from accidental operation.

With the movement selection lever in position other than "N", it is not possible to start the engine.

The movement selection lever, at the left of the steering wheel, allows to set the direction of travel of the machine.

- Pull the lever towards the steering wheel and push it forward ("F" direction) to proceed forward.
- Pull the lever towards the steering wheel and pull it back ("R" direction) to proceed in reverse. When driving in reverse, an alarm sounds intermittently.

While holding the lever in an intermediate position "N" the transmission is in neutral and the vehicle is partially braked.

With the forward/reverse movement gear selection lever in position other than "N", the engine will not start.

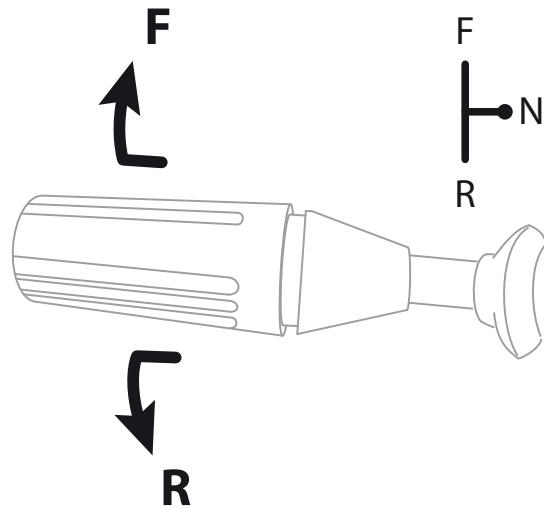

#### Unstable control lever



#### ATTENTION

With the movement selection lever in position other than "N", it is not possible to start the engine.

The movement selection lever, at the left of the steering wheel, allows to set the direction of travel of the machine.

- Pull the lever upwards ("F" direction) to travel forward.
- Pull the lever downwards ("R" direction) to travel in reverse. When driving in reverse, an alarm sounds intermittently.
- Push the lever towards the steering wheel ("N" position); the transmission is in neutral and the vehicle is partially braked.



#### NOTE

**After selecting the direction, the spring inside the lever will make it return to the central position, without modifying the selected direction.**

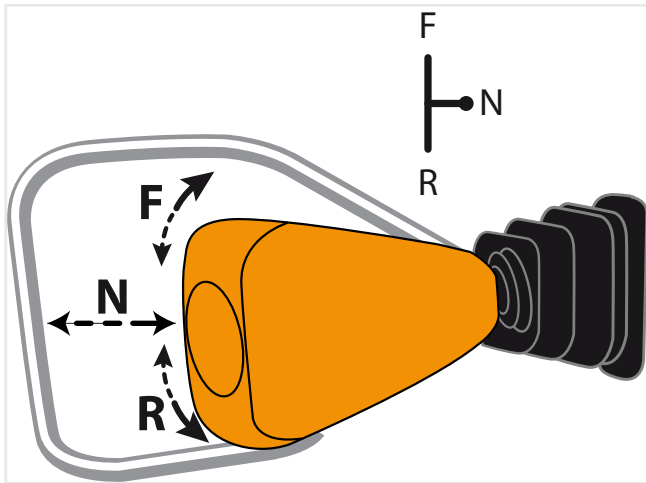

After selecting a direction of movement, the corresponding indicator lights on the instrument panel turn on:

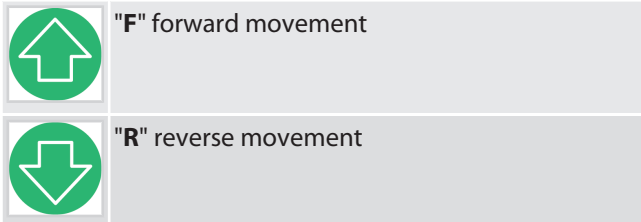

The movements of the lever are not active when:

- The handbrake is engaged
- The operator is not properly seated in the driver's seat



### NOTE

**If the operator is not sitting properly in the driver's seat, the transmission is automatically switched off.**



### WARNING

**After selecting the vehicle movement direction, it starts suddenly to move in the selected direction.**

Before selecting the movement direction make sure that nobody is standing near the vehicle.



### WARNING

**It is dangerous to operate the movement selection lever with the engine at high rpm or at a speed higher than 2 km/h (1.2 mph).**

Before reversing the direction of movement, minimize the engine speed and select the new direction. Danger of vehicle overturning severe breakage of mechanical parts.

## 7.16.2 - Mechanical transmission

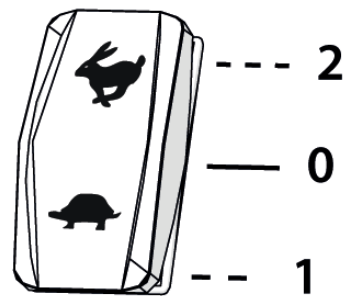

Figure: Fig. 180409-1

The button (fig. 180409-1) allows changing the manual gear shift.

Shift the slow gear (tortoise) to operate on the work site.

Shift the fast gear (hare) for long trips with no load, at clear work sites, with good visibility, in the absence of obstacles, with consistent and level ground floor, without transit of people.

To change the manual gear shift:

- Stop the vehicle completely.
- Press and hold down the service brake pedal.
- Press the button (fig. 180409-1) for a few seconds:
  - Down to shift the Slow gear, the related indicator light on the instrument panel turns on to indicate its selection.
  - Up to shift the Fast gear, the related indicator light on the instrument panel turns on to indicate its selection.
- Wait that the related indicator light turns on.
- Release the brake pedal.
- Drive slowly and gradually to allow the gear to fit properly.



**WARNING**

**Risk of damage to the transmission.**

Do not attempt a U-turn when the speed is higher than 30 Km/h. If incorrectly requested by the operator, it will trigger an acoustic and visual warning (error code) for a few seconds.

7.16.2.1 - Manually disable off the 2-gear hydrostatic transmission



**DANGER**

Deactivate the traction only in case it is necessary to tow the vehicle in case of damage to the engine and/or transmission.

In case it is necessary to tow the vehicle with the engine and/or transmission failure, it is possible to manually disable the transmission.

Carry out the following operations:

- Make sure that the vehicle engine is turned off
- Place chocks under the wheels to prevent sudden movements of the vehicle
- Turn the lever of the hydraulic valve (fig. 150745-1), to turn off the hydraulic supply to the reduction gear (the valve is located under the vehicle, near the reduction gear).

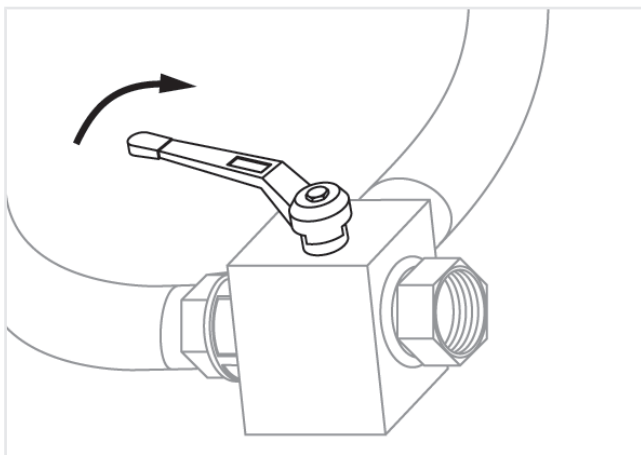

Figure: 150745-1

**DANGER! Rotating the handle a jet of oil under pressure may leak out from the valve. Use appropriate safety equipment to protect eyes and skin from hot oil under pressure.**

- Using a screwdriver, move the gear selection pin in neutral, at half stroke "2" (fig. 150745-2)
- If possible, before towing the vehicle turn on the instrument panel and check that the indicator lights of the forward and reverse gear are off.

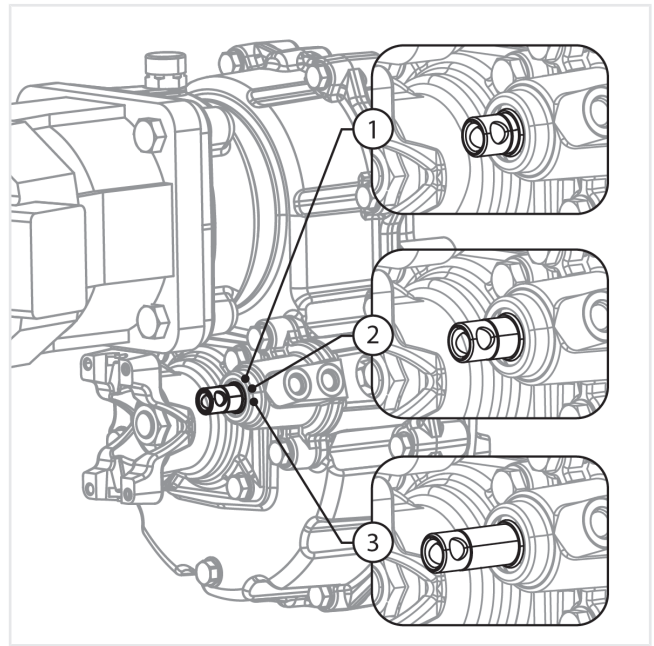

Figure: 150745-2



**ATTENTION**

Once the towing operations are completed open the valve again returning the lever (fig. 150745-1) to the starting position.

7.16.3 - Service braking pedal

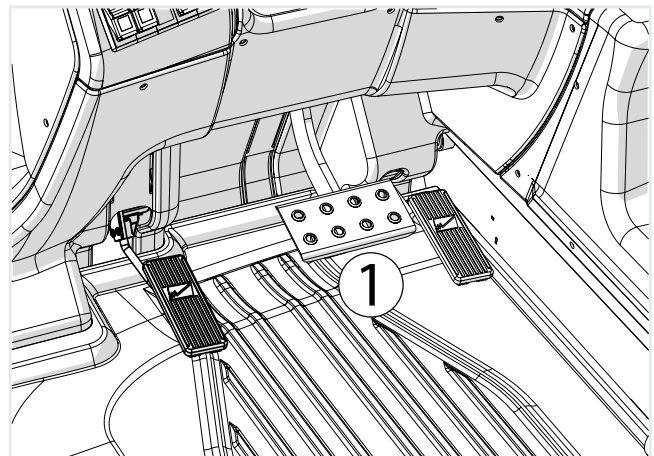

Figure: 150311-1

Press the service brake pedal "1" (fig. 150311-1) to slow down or stop the vehicle.

The pedal acts directly on the service brakes inside the differential axles.

When the brake pedal is pressed the stop lights of the rear lights go on. The lights remain in operation until the pedal is released.

Periodically check that both lights are working.



150311-2



### WARNING

In the case of restricted use of the pedal periodically check its proper operation. In case of problems contact the *Dieci* service center.



### DANGER

If the warning light (fig. 150311-2) turns on intermittently, it indicates a low brake fluid level.

If the warning light (fig. 150311-2) turns on in a fixed way, the parking brake is stuck or damaged.

Do not use the vehicle until the problem has been solved. Contact a *Dieci* service center.

## 7.16.4 - Inching Pedal

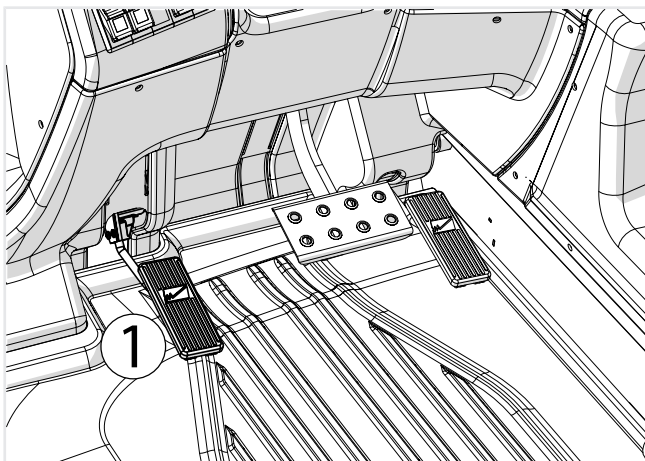

Figure: 150740-1

The inching pedal "1" (fig. 150740-1) acts directly on the hydrostatic transmission and allows to slow down the vehicle forward movement.

The pedal allows slow and precise forward movements with high rpm heat engine.

With pedal fully pressed, the vehicle stops the forward movement.



### DANGER

Do not press the inching pedal at high speeds, the vehicle brakes suddenly and the diesel engine risks over-revving.

## 7.16.5 - Accelerator pedal

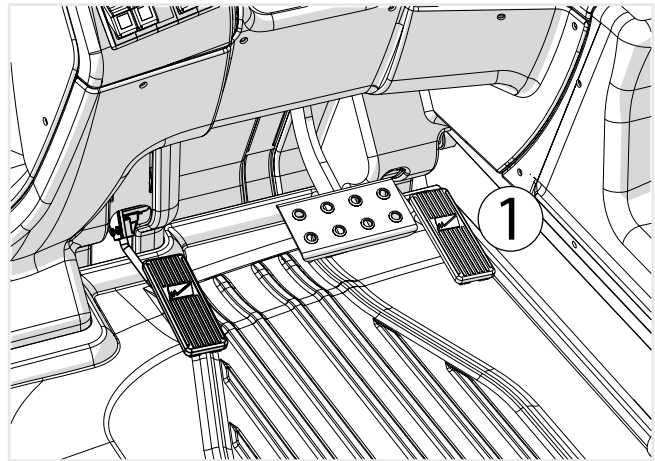

Figure: 150741-1

Press the accelerator pedal "1" (fig. 150741-1) to increase the engine speed, when the pedal is released the engine rpm will decrease.

The pedal acts directly on the injection pump of the engine.



### WARNING

If while driving, the vehicle exceeds the maximum allowed speed, the "Over speed protection" transmission electronic control goes into operation. The function automatically limits the vehicle speed in order to prevent transmission and diesel over revving. Triggering of the "Over speed protection" function is signaled by the general alarm warning light switching on and the intermittent acoustic signal.

If the function intervenes, the operator must lift his foot from the accelerator pedal and reduce the speed of the vehicle.



### NOTE

The maximum speed of the vehicle varies with the inflation pressure and the size and wear of the tires.

### 7.16.6 - CREEP mode

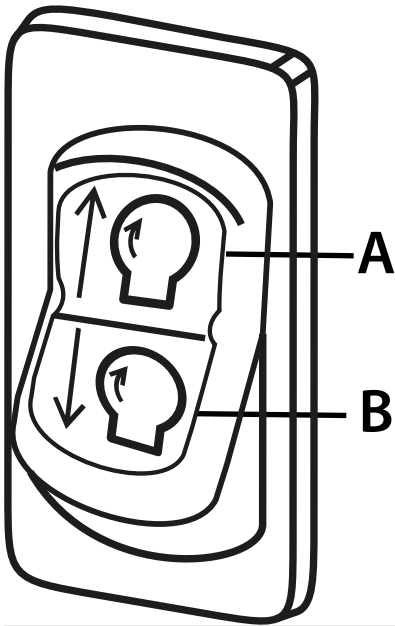

Figure: 180362-1

With vehicle stopped, to activate the CREEP mode press the switch (fig. 180362-1) on the "A" upper side to increase the engine rpm or the "B" lower side to decrease the engine rpm.

Pressing the accelerator pedal determines the translation speed associated to the engine rpm set with the hand throttle.

To increase (or decrease) the engine rpm, press the switch multiple times, as keeping it pressed will cause no change.



#### NOTE

**To deactivate the hand throttle, first return to the Low value of the diesel engine.**

## 7.17 - Remote Control \*



### NOTE

\* The Remote control is an optional accessory.

### 7.17.1 - Remote control with levers: Description

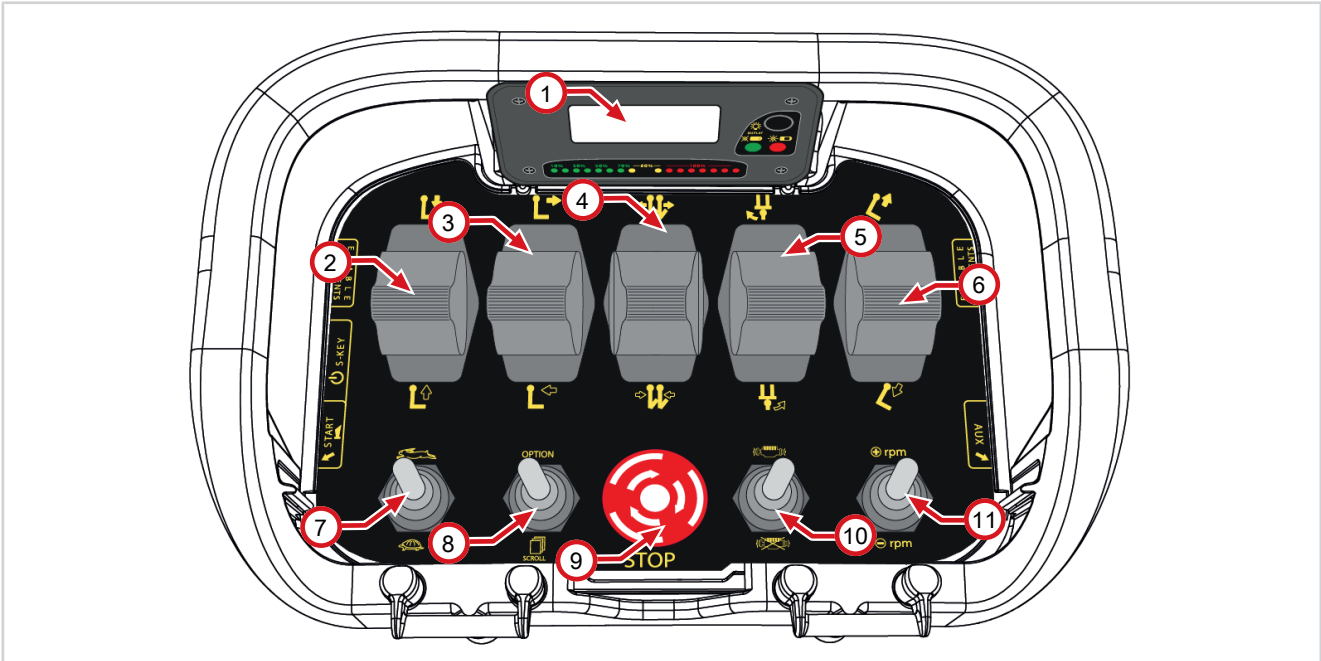

Fig. 160601-1

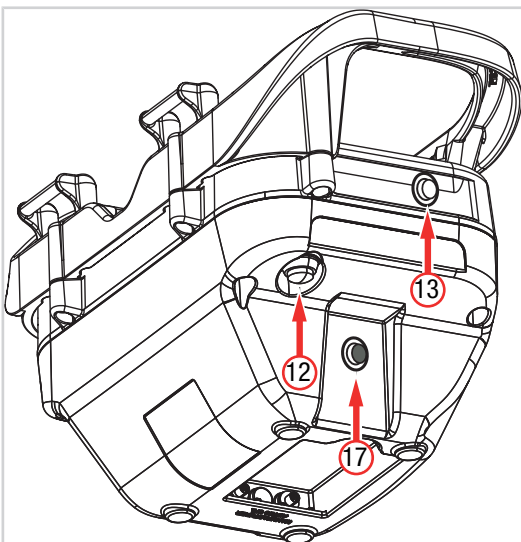

Fig. 160601-2

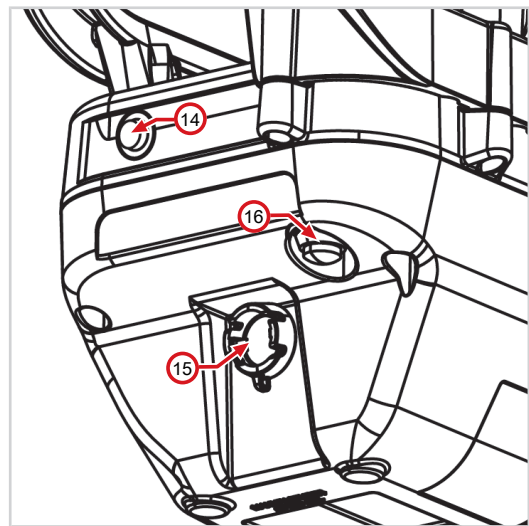

Fig. 160601-3

1	LCD display	9	Emergency stop button
2	Boom lowering / lifting lever	10	Vehicle ignition switch
3	Boom extension / retraction lever	11	Accelerator lever
4	Services lever	12	Electric contact on boom head button
5	Turret rotation lever (for rotating vehicles)	13	Not used

6	Up / down tilting lever	14	Not used
7	Movements speed lever	15	Remote control on/off key
8	Boom head solenoid valve lever	16	Remote control and horn enable button
17	Wired control connector		

Table 1: Remote control description

7.17.1.1 - Remote control display

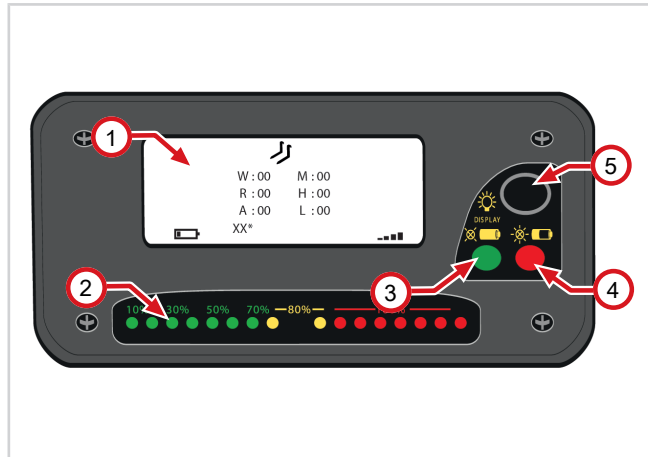

	Description
1	LCD display
2	Anti-tipping led signaling
3	Remote control status LED
4	Remote control battery status LED
5	Not used
W	Current weight
M	Maximum weight
R	Radius
H	Load height from the ground
A	Boom angle
L	Boom extension length
xx*	Installed equipment code
	Forks operating mode icon
	Hook operating mode icon
	Basket operating mode icon
	Battery charge level
	Remote control signal level
	Fuel low level icon











	Description
	General alarm icon
	Active electric contact icon
	Solenoid valve on boom head icon
	F1 function icon (optional depending on the equipment installed)
	F2 function icon (optional depending on the equipment installed)
	F3 function icon (optional depending on the equipment installed)
	F4 function icon (optional depending on the equipment installed)
	High particulate accumulation in the DPF icon
	AdBlue low level icon
	Chains error icon (present if the vehicle is prearranged with PLE)
	Levelness icon (present if the vehicle is prearranged with PLE)

Table 2: Display description and legend





**7.17.1.2 - Remote control emergency stop button**

The emergency stop button "9" (fig. 160601-1) turns off the diesel engine of the vehicle and the remote control, stopping all movements of the vehicle and of the equipment.

**7.17.1.3 - Movements speed lever**



The movements speed lever "7" (fig. 160601-1) allows to set the vehicle boom speed.

	Move the lever up to set the fast movements (hare symbol)
	Move the lever down to set the slow movements (turtle symbol)

**Using the basket, only slow movements are enabled.**

**7.17.1.4 - Accelerator lever**

The throttle lever "11" (fig. 160601-1) allows to maintain constant diesel engine revolutions of the vehicle.

	Move the lever forward to increase the engine rpm of 200 rpm.
	Move the lever backward to decrease the engine rpm of 200 rpm.

**7.17.1.5 - Remote control on/off key**

The on/off key "15" (fig. 160601-3) allows to turn on and turn off the remote control. To turn on the remote control, turn the knob from position O to position I.

**7.17.1.6 - Remote control and horn enable button**

The button "16" (fig. 160601-3) is used both to enable the remote control commands and to operate the horn of the vehicle.

**7.17.1.7 - Boom control levers**



The boom control levers are used to carry out various movements:

**Boom lowering / lifting lever "2" (fig. 160601-1)**



	Boom down
---	-----------

	Boom up
---	---------



**Boom extension / retraction lever "3" (fig. 160601-1)**

	Boom extension
	Boom retraction

**Services lever "4" (fig. 160601-1)**

	Services
	Services

**Turret rotation lever "5" (fig. 160601-1) [if present]**

	Turret counterclockwise rotation
	Turret clockwise rotation

**Tilting lever "6" (fig. 160601-1)**

	Tilting downwards
	Upwards Tilting

**7.17.1.8 - Electric contact on boom head button**

The button "12" (fig. 160601-2) allows to activate the electrical contact on the boom head (if present). Press again the button to disable the electrical contact on the boom head.

**7.17.1.9 - Boom head solenoid valve lever**

The lever "8" (fig. 160601-1) allows to activate the solenoid valve on the boom head (if present).

### 7.17.1.10 - Wired control connection

The wired control cable is provided to connect the receiver and the transmitter in case of environments that do not allow using remote control or when the battery is too low.

Connect the "A" connector to the "17" connector of the remote control and to the "B" connector of the vehicle.

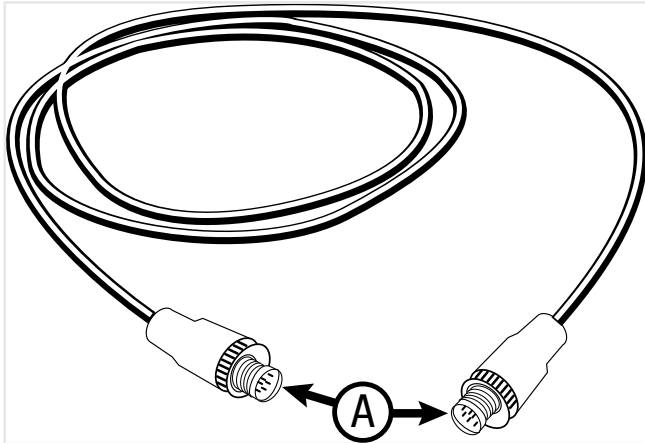

Figure: Wired control

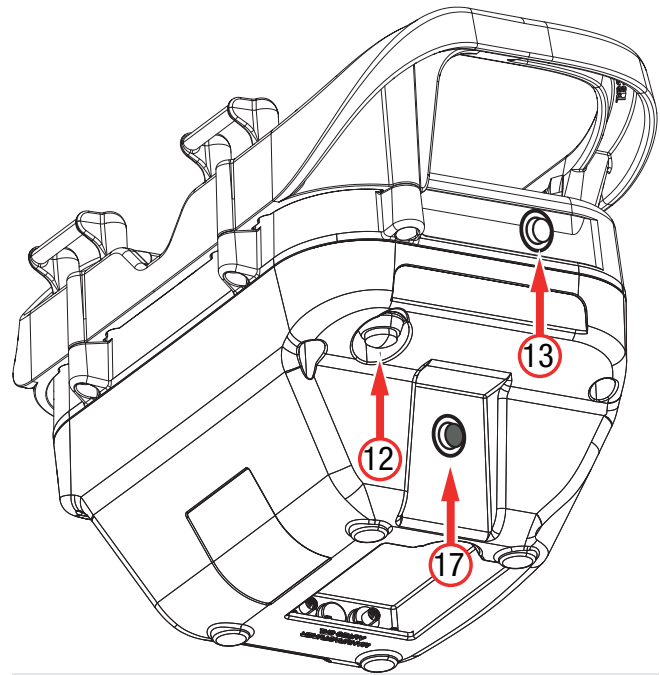

Figure: Wired control connection to remote control

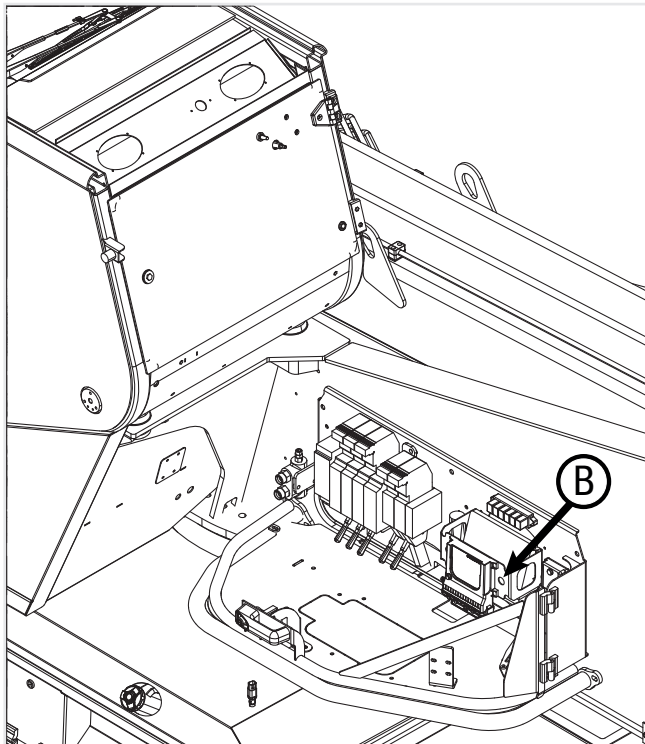

Figure: Wired control connection to the vehicle

7.17.2 - Remote control with joystick: Description

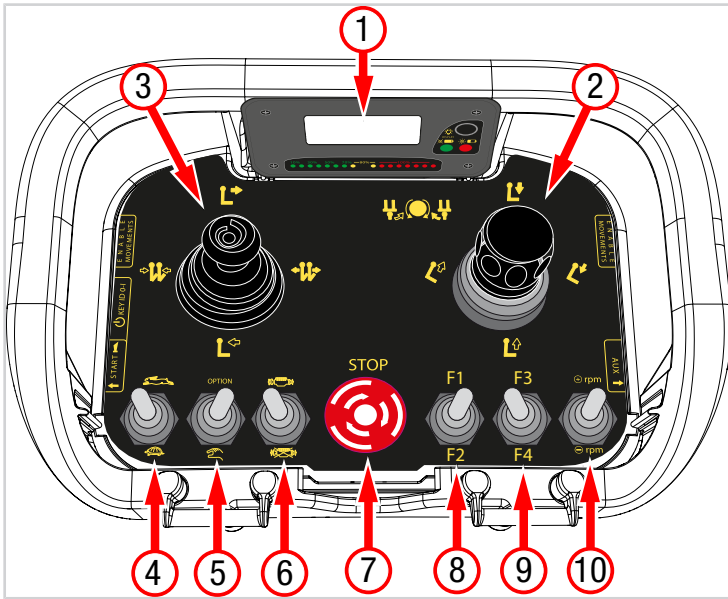

Fig. 160601- 4

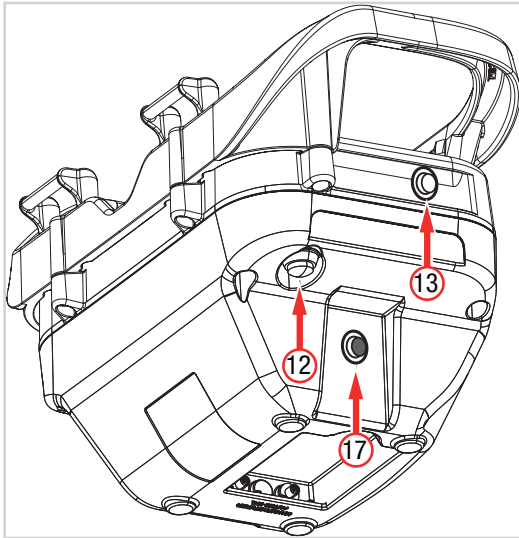

Fig. 160601- 5

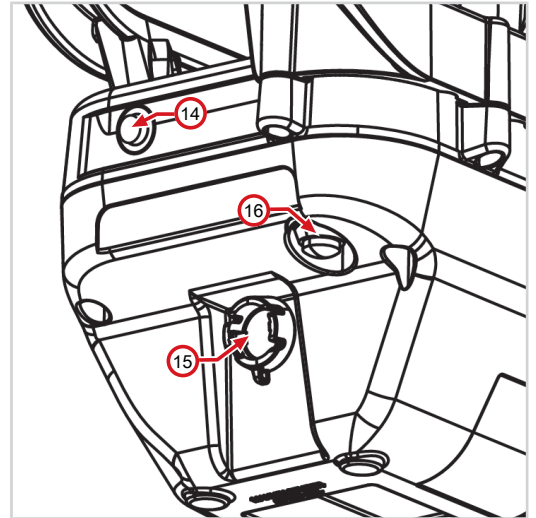
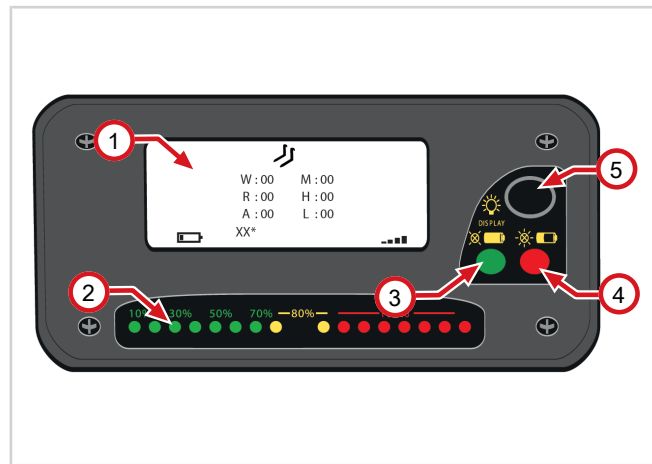

Fig. 160601- 6

1	LCD display	9	Machine equipment functions lever (F3) (F4 NOT USED)
2	Boom lower / boom raise / tilting down / tilting on services / turret rotation (for rotative vehicles) joystick	10	Accelerator lever
3	Boom extension / boom retraction joystick	12	Electric contact on boom head button
4	Movements speed lever (the hare function with basket equipment is disabled)	13	Right deadman button
5	Boom head solenoid valve lever	14	Left deadman button
6	Vehicle ignition switch	15	Remote control on/off key
7	Emergency stop button	16	Remote control and horn enable button
8	Machine equipment functions lever (F1-F2)	17	Wired control connector

Table 3: Remote control description

## 7.17.2.1 - Remote control display



	Description
1	LCD display
2	Anti-tipping led signaling
3	Remote control status LED
4	Remote control battery status LED
5	Not used
W	Current weight
M	Maximum weight
R	Radius
H	Load height from the ground
A	Boom angle
L	Boom extension length
xx*	Installed equipment code
	Forks operating mode icon
	Hook operating mode icon
	Basket operating mode icon
	Battery charge level
	Remote control signal level
	Fuel low level icon
	General alarm icon
	Active electric contact icon
	Solenoid valve on boom head icon
	F1 function icon (optional depending on the equipment installed)







	Description
	F2 function icon (optional depending on the equipment installed)
	F3 function icon (optional depending on the equipment installed)
	F4 function icon (optional depending on the equipment installed)
	High particulate accumulation in the DPF icon
	AdBlue low level icon
	Chains error icon (present if the vehicle is prearranged with PLE)
	Levelness icon (present if the vehicle is prearranged with PLE)

Table 4: Display description and legend

### 7.17.2.2 - Remote control emergency stop button

The emergency stop button "7" (fig. 160601-4) turns off the diesel engine of the vehicle and the remote control, stopping all movements of the vehicle and of the equipment.

### 7.17.2.3 - Movements speed lever

The movements speed lever "4" (fig. 160601-4) allows to set the vehicle boom speed.

	Move the lever up to set the fast movements (hare symbol)
	Move the lever down to set the slow movements (turtle symbol)

**Using the basket, only slow movements are enabled.**

### 7.17.2.4 - Accelerator lever

The throttle lever "10" (fig. 160601-4) allows to maintain constant diesel engine revolutions of the vehicle.

	Move the lever forward to increase the engine rpm of 200 rpm.
	Move the lever backward to decrease the engine rpm of 200 rpm.

### 7.17.2.5 - Remote control on/off key

The on/off key "15" (fig. 160601-6) allows to turn on and turn off the remote control. To turn on the remote control, turn the knob from position O to position I.

### 7.17.2.6 - Remote control and horn enable button

The button "16" (fig. 160601-6) is used both to enable the remote control commands and to operate the horn of the vehicle.

### 7.17.2.7 - Boom control joystick "2"

The boom control joystick is used to carry out various movements:

Boom lower / raise movements joystick "2" (fig. 160601-4)

	Boom down
	Boom up

Turret rotation joystick "2" (fig. 160601-4) [if present]

	Turret counterclockwise rotation
	Turret clockwise rotation

Tilting joystick "2" (fig. 160601-4)

	Tilting downwards
	Upwards Tilting

### 7.17.2.8 - Boom control joystick "3"

The boom control joystick is used to carry out various movements:

Boom extension / retraction lever "3" (fig. 160601-4)

	Boom extension
	Boom retraction

Services lever "3" (fig. 160601-4) used with F1-F2-F3 for positive / negative jib movements

	+ F1 Jib up
	+ F2 Jib extension
	+ F3 Counterclockwise jib rotation
	+ F1 Jib down
	+ F2 Jib retraction
	+ F3 Clockwise jib rotation

**7.17.2.9 - Electric contact on boom head button**

The button "12" (fig. 160601-5) allows to activate the electrical contact on the boom head (if present). Press again the button to disable the electrical contact on the boom head.

**7.17.2.10 - Boom head solenoid valve lever**

The lever "5" (fig. 160601-4) allows to activate the solenoid valve on the boom head (if present).



Confirm the attached equipment



**NOTE**

**With baskets correctly installed it is not necessary to press OK.**

**7.17.2.11 - Machine equipment functions levers**

The "8" and "9" levers (fig. 160601-4) duplicate the F1 - F2 - F3 keys of the cab left joystick.

**7.17.2.12 - Wired control connection**

The wired control cable is provided to connect the receiver and the transmitter in case of environments that do not allow using remote control or when the battery is too low.

Connect the "A" connector to the "17" connector of the remote control and to the "B" connector of the vehicle.

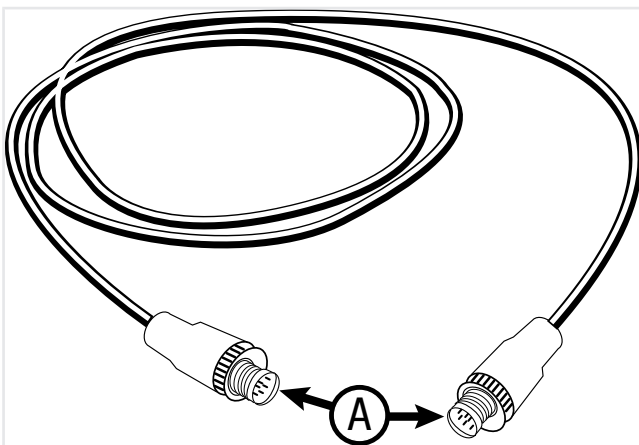

Figure: Wired control

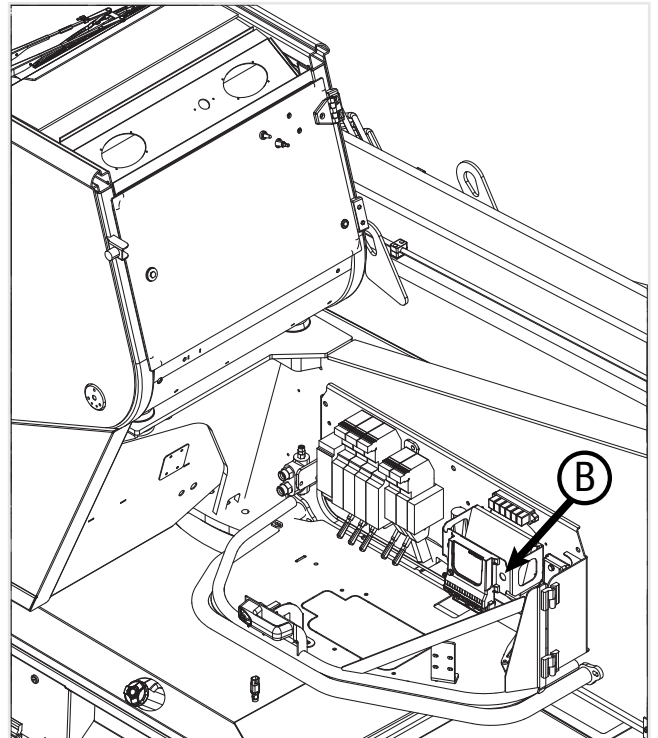

Figure: Wired control connection to the vehicle

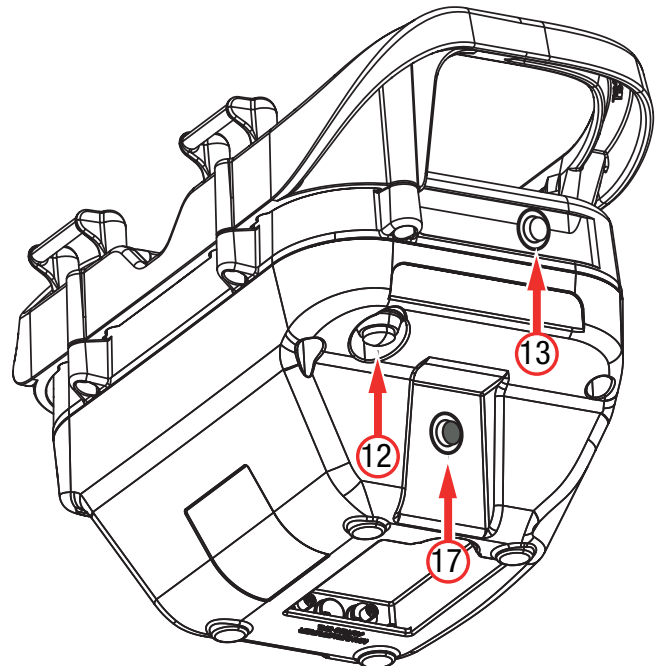

Figure: Wired control connection to remote control

**7.17.3 - Remote Control: Use**

The vehicle, if prepared, can be used by the remote control.

The movements that can be performed from the remote control are:

- Telescopic boom extension/retraction.
- Telescopic boom Up/Down movement.
- Tilting.
- Turret rotation

- Services.

To use the vehicle by remote control carry out the following operations:

#### Operations on the vehicle:

Assemble the equipment on the vehicle, if not already installed. (Refer to the chapter "Equipment installation" and set the correct mode of use of the vehicle)

- Lay the load on the ground.
- Level the vehicle (if available).
- Place the vehicle on outriggers.
- Place the gear lever to neutral "N" position.
- Engage the parking brake.
- Press the switch "1" (fig. 150912-1) to enable the controls from the remote control. Pressing the switch will automatically shut down the vehicle engine.

Turn the vehicle ignition key in position "I" without starting the engine.

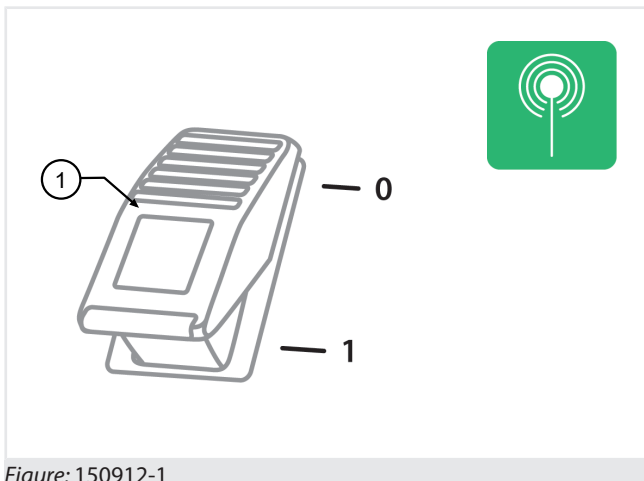

Figure: 150912-1

#### Operations on the remote control:

- Turn the remote control on/off knob "15" (fig. 150912-2) to position "I".
- Press the remote control on/off button "16" to enable the remote control.
- Move the vehicle on/off lever "4" (fig. 150912-3) up and hold it for 2 seconds.

The ON remote control indicator light will flash green until the remote control will remain on.

When switching on the remote control, it will emit an alert tone.

If the gear lever of the vehicle is not in position "N", the vehicle will not turn on.

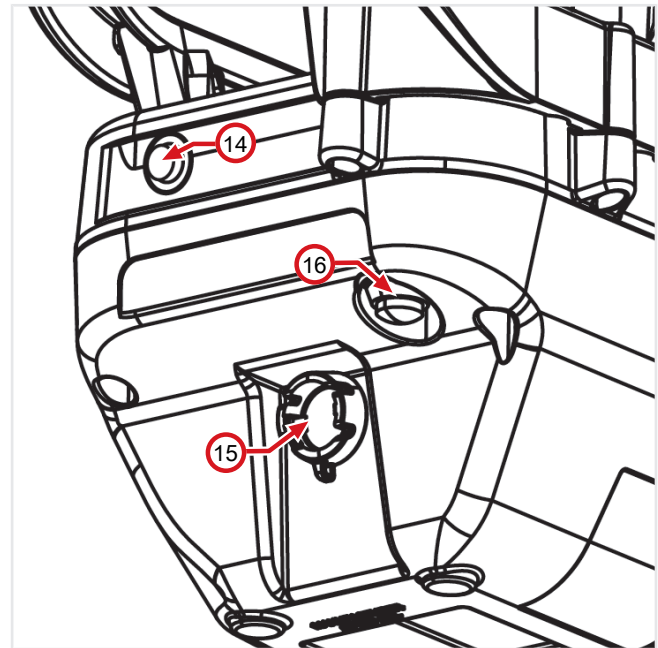

Figure: 150912-2

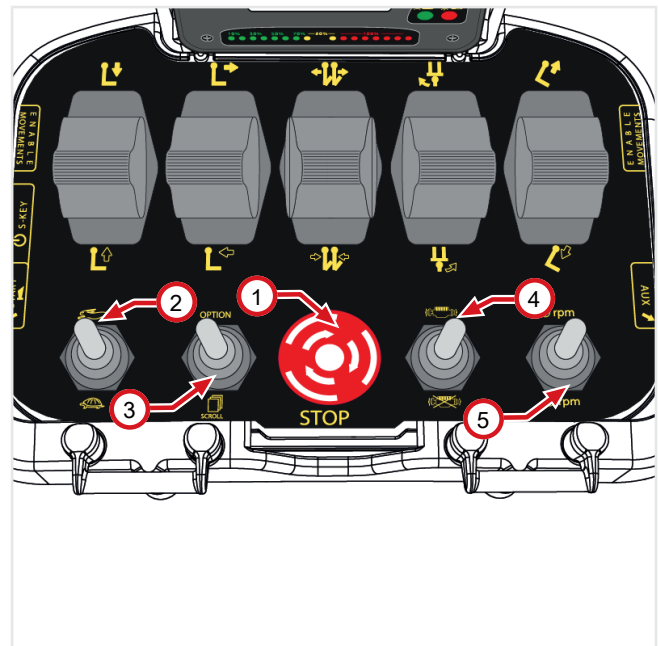

Figure: 150912-3



### WARNING

Always remain at a safe distance from the vehicle and from the load, outside the area that would be occupied in case of vehicle overturning and load fall.

When using the vehicle with remote control:

- The emergency button in the cab is always active.
- The gear of the vehicle is inhibited.





**NOTE**

After 4 min of non-use of the remote control, the remote control and the vehicle will turn off.



**ATTENTION**

**When using the vehicle with remote control, a red flashing light on the vehicle comes into operation when the vehicle reaches the tipping limit.**

To reset the vehicle in safe conditions, make movements that do not aggravate the stability depending on the type of equipment currently used.

**7.17.4 - Remote Control: Turn off the vehicle and the remote control**

To turn off the machine engine and the remote control, turn the ignition knob from position "1" to position "0".

**7.17.5 - Remote Control: Receiver**

The remote control receiver is installed on the rear of the vehicle. When the remote control is selected in the cab, the receiver turns on. For the operating specifications carefully read and learn the use and maintenance instructions of the remote control manufacturer.

**7.17.6 - Remote Control: Recharge**

At the seat side there is the remote control battery charger.

**7.17.7 - Remote Control: Back-up**

If the transmitter unit can not be used, it can be replaced by a Transmitting Unit called "BACK-UP UNIT", to be requested to Autec.

It is identical to the Unit that can no longer be used and is distinguished only by the presence of the word "BACK-UP UNIT" in the battery housing.



**ATTENTION**

Insert the "Key ID 0-1" or the "ID internal tx memory" of the transmitting unit that is no longer usable in the "BACK-UP UNIT" and perform the procedure for storing the address described below.

**Storing the address**

With the battery charged and the ignition key inserted in the "BACK-UP UNIT", carry out the following procedure:

- press the STOP button,
- Press the START button and keep it pressed until the green LED turns off,
- disengage the STOP button.

Now it is possible to start the Remote control and command the vehicle with the "BACK-UP UNIT" transmitting unit.

**7.17.8 - Remote Control: Additional information**



**NOTE**

For additional information on the use and maintenance of the remote control, refer to the specific manual of the remote control.

**7.18 - Automatic differential lock \***



**NOTE**

\* The automatic differential lock is an optional setup.

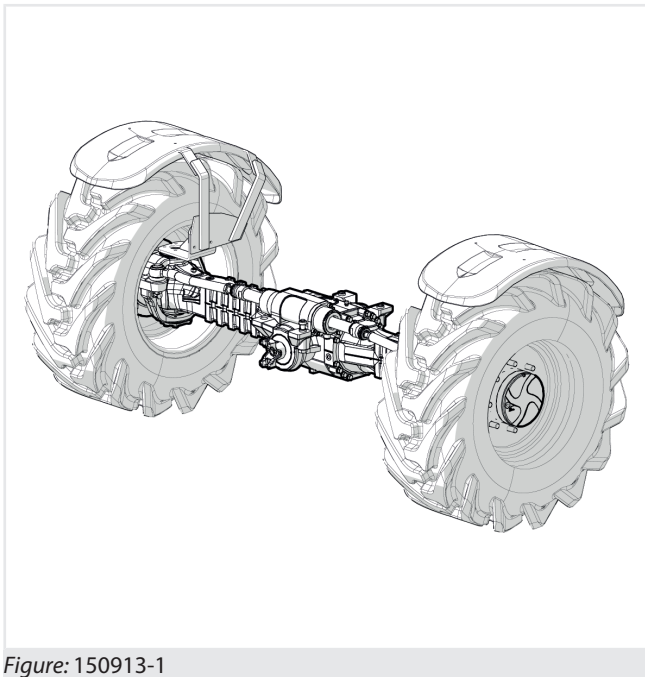

Figure: 150913-1

The operation of the automatic differential Lock on the 2nd axle (fig. 150913-1) starts automatically in the event of a slip over 45% of one of the two wheels.

## 7.19 - Automatic axle swing lock

The automatic axle swing lock avoids possible oscillations of the vehicle during the working operations when the vehicle is used on wheels.

The indicator lights 1, 2 and 3 (fig. 150914-1) indicate which axles are locked at that time.

The deck swing lock is automatically activated depending on the position of the turret:

- when the turret is located within  $\pm 10^\circ$  rotation with respect to the front position ("A" area) only the front axle is locked.
- when the turret is located beyond  $\pm 10^\circ$  rotation with respect to the front position ("B" area) both axles are locked: front and rear.
- If the vehicle is equipped with the optional "reversed driving" option, when the turret is located within  $\pm 2^\circ$  rotation with respect to the  $180^\circ$  rotated position ("C" area) only the rear axle is locked.

**NOTE!** If both axles of the vehicle are locked by the automatic axle swing lock, the gear of the vehicle is inhibited. To travel it is necessary to move the turret in line with the vehicle.

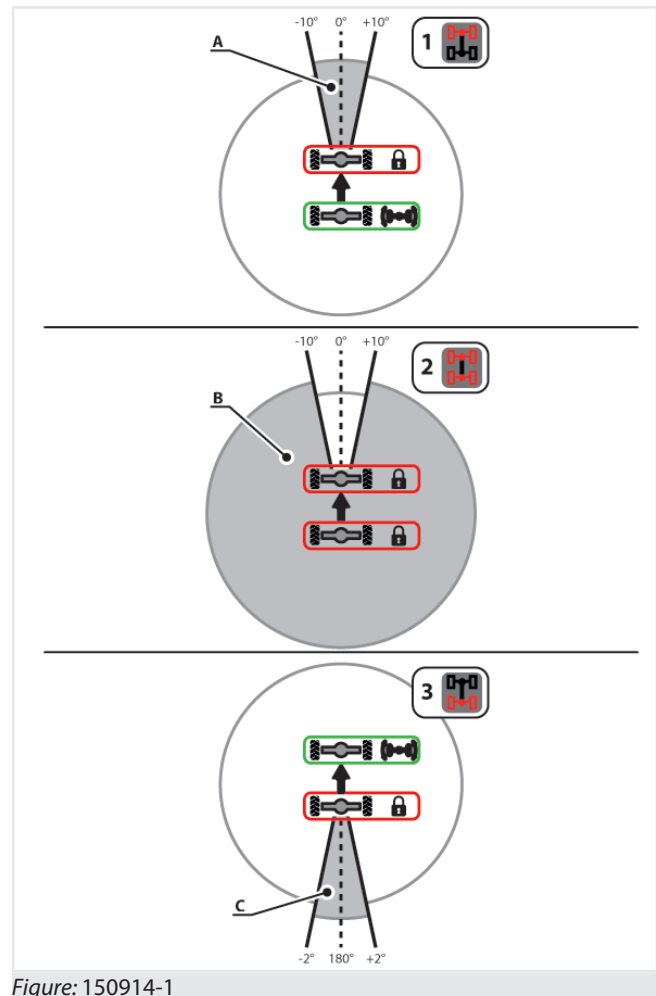
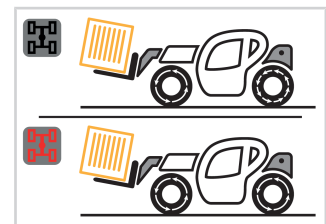

Figure: 150914-1

## 7.20 - Central differential lock

121171-1



151171-2

The button "1" (121171-1) allows to lock the central differential of the vehicle in case all the wheels of the front or rear axle are slipping.

**To activate the central differential locking it is necessary to:**

- Stop the vehicle
- Press the inching pedal and brake service pedal
- Press the button "1"

With activated central differential lock, the indicator light "A" will flash on the dashboard.

**To unlock the central differential it is necessary to:**

- Stop the vehicle
- Press the inching pedal and brake service pedal
- Press the button "1"

With deactivated central differential lock, the indicator light "B" will be displayed on the dashboard.

- From the left side "2" to tilt the vehicle to the left.



**DANGER**



**It is not possible to work with tilting greater than 2°. Danger of transverse tipping.**

Use the spirit level in the cab to check the inclination of the vehicle.



**DANGER**

**It is not possible to level the machine when the attachment holding plate is more than 2 meters high. Danger of transverse tipping. With the man basket connected, level the machine only when the boom is retracted and lowered.**

**7.21 - Automatic fan reversal**

The fan reversal allows precisely the radiator fan reversal to clean the radiator from any dirt deposits such as dust and straw.

The cleaning cycle is automatically activated when the vehicle is turned on and subsequently every hour of continuous work.

The reversal is carried out automatically without having to stop the vehicle.

The fan will remain in the "cleaning" position (reversed motion) for a time preset by the manufacturer.



**ATTENTION**

The fan reversal presence does not exempt the user from cleaning the fan, radiator and engine compartment, at the intervals indicated by regular maintenance.

**7.23 - Boom down control valve \***



**NOTE**

\* The boom down control valve is a standard accessory. It is not present in the case in which the vehicle is prepared for the use of the man basket or the telescopic boom has more than one extension.

**7.22 - Transverse levelling \***



**NOTE**

The transverse levelling device is an optional accessory.

The transverse levelling device allows to adapt the vehicle to the transverse inclination of the ground.

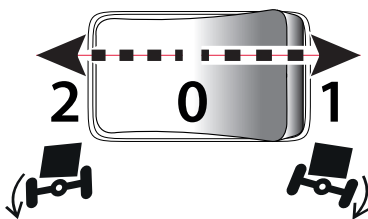

Figure: 171217-1

To level the vehicle it is necessary to:

- Position the load on the ground.
- Lower and fully retract the telescopic boom.
- Press the transverse levelling device button (fig. 171217-1):
  - From the right side "1" to tilt the vehicle to the right.

The boom down control valve allows the operator to obtain the maximum lowering speed of the boom also at the minimum number of revolutions of the engine; the boom movement speed depends only on the proportional controls of the joystick.

The boom down control valve arm allows faster and more precise movements of the boom and a fuel saving during the boom down movement.

When present, the boom down control valve is always active.

**7.24 - Engine**

**7.24.1 - AdBlue®**

AdBlue® is a registered trademark of Verband der Automobilindustrie (VDA).

AdBlue is used in the selective catalytic reduction (SCR) to reduce emissions of nitrogen oxides from the exhaust gases produced by vehicles equipped with a diesel engine.

The solution is non-toxic, non-flammable and is not dangerous to handle. However, the solution can be corrosive to some metals and must be stored and transported using the proper materials.



## NOTE

Refer to the instructions on the packaging regarding transportation, handling or storage.

### 7.24.1.1 - AdBlue®: The risks of an AdBlue out of specification

The SCR systems are very sensitive to the quality of AdBlue used.

It is extremely important that the AdBlue complies with the specifications and has not been contaminated during transport, handling or storage.

A key aspect to consider is that the damage that can result from an AdBlue containing calcium or metals out of specification are not immediately visible, but appear after a certain time, and even after many kilometers.

In summary the problems that can arise from a low quality AdBlue are of two types: aging and poisoning of the catalyst

- Aging is typically given by the presence of substances that causes the catalyst to loose its efficiency and reduce its life and ability to operate (reducing the usable area). The catalyst is designed to last the lifetime of the vehicle while if AdBlue with parameters (e.g. Calcium) out of specification is used, it will last less and must be replaced with high costs.
- Poisoning is typically due to the presence of metals (e.g. Zinc or copper) or pollutants (which should never be present in the AdBlue) as it immediately ruins the catalyst and makes it unusable. The result is an immediate need to replace the catalyst in order to enable the SCR system operation again.

Therefore aging takes place slowly and stops the vehicle after a long time while poisoning is rather immediate and immediately stops the vehicle. Both, however, require costly catalyst replacement and can be prevented only using high quality AdBlue without contaminants.

### 7.24.1.2 - AdBlue®: Specifications

Specifications of AUS32 (AdBlue®) Complying with DIN 70070

Urea 32.5 % - solution in water			
Characteristics	Min	Max	Reference unit
Urea content	31.8	33.2	% of weight
Density at 20°C	1.0870	1.0930	g/cm <sup>3</sup>
Refractive index at 20°C	1.3814	1.3843	
Alkalinity as NH <sub>3</sub>	-	0.2	%
Biuret	-	0.3	%
Aldehyde	-	5	mg/kg
Insoluble	-	20	mg/kg
Phosphates (PO <sub>4</sub> )	-	0.5	mg/kg
Calcium	-	0.5	mg/kg
Iron	-	0.5	mg/kg
Copper	-	0.2	mg/kg
Zinc	-	0.2	mg/kg
Chromium	-	0.2	mg/kg
Nickel	-	0.2	mg/kg
Aluminum	-	0.5	mg/kg
Magnesium	-	0.5	mg/kg
Sodium	-	0.5	mg/kg
Potassium	-	0.5	mg/kg

### 7.24.1.3 - AdBlue® tank filling



## WARNING

### Danger of burns caused by boiling hot AdBlue®

In the following situations, the AdBlue® pipes are under pressure:

- With engine running
- After turning off the engine

Opening the fueling system, the leakage of boiling hot AdBlue®/DEF may cause burns.

- Cool the engine before opening the fueling system.
- Always wear protective gloves, clothing, and goggles to open the system.
- Slowly open the pipe fittings and the clamping elements of the system components.



**WARNING**

**Damage to the engine caused by the presence of AdBlue® in the fuel**

The AdBlue® must not be refilled into the fuel tank. Fill AdBlue® exclusively in the AdBlue® tank. Avoid excessive filling of the AdBlue® tank.



**WARNING**

**When opening the AdBlue® tank, small amounts of ammonia vapor may escape.**

Fill the AdBlue® tank only in well-ventilated environments. Avoid AdBlue® contact with skin, eyes or clothing. Keep children away from the AdBlue®

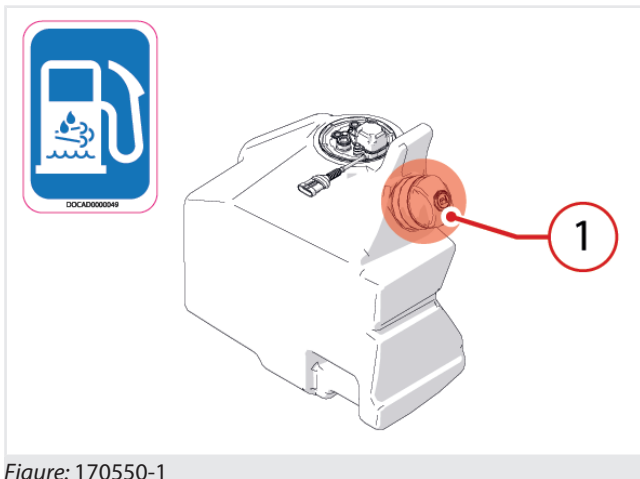

Figure: 170550-1

To top up the AdBlue level (fig. 170550-1) it is necessary to:

- Park the vehicle and turn off the engine.
- Allow the engine to cool down.
- Open the Ad-Blue tank cap "1".
- Fill up.
- Close the Ad-Blue tank cap.



Figure: 170550-2

**7.24.1.4 - After run**

The After run indicator is lit until the Urea circuit is operating and stays on until **90 seconds** after the machine engine was turned off.



In this period of time an electric pump will drain the urea circuit

**7.24.1.5 - DPF regeneration**



**WARNING**

**DO NOT turn the engine off during the regeneration phase.**

### 7.24.1.6 - AdBlue error list



#### NOTE

In case the vehicle is in error, contact a *Dieci* service center to solve the problem, indicating the error code reported.

For more information about the errors display, refer to the "Central instrument panel" chapter.

### 7.24.2 - FPT Series N Stage V engine



#### NOTE

The use and maintenance manual of the engine is an integral part of the documentation supplied with the vehicle.

Consult the engine manual or contact an authorized workshop for maintenance.

We recommend that you carefully read the information contained in the instruction manual and comply with them: in this it is possible to avoid accidents, enjoy the manufacturer's warranty and always have an engine in peak operating condition.

### 7.24.2.1 - Validation procedure



Figure: fig. 160801-1



Figure: fig. 160801-2



Figure: fig. 160801-3

If the engine shows an error to the exhaust gas treatment system, the validation procedure is started.



#### ATTENTION

**Do not use the vehicle if the validation procedure screen is shown.**

Contact the authorized service to resolve the problem.

The validation procedure includes 3 levels, in which the system carries out checks on the engine and on the exhaust gas treatment system to check its correct operation.

Each level of the validation procedure requires a time of 30 minutes, in which the system carries out the necessary checks. If the checks are successful, the validation procedure is terminated and the display will return to the HOME page display. Otherwise, the validation procedure will pass to the next level and the 30-minute countdown starts again.

**7.24.2.2 - AdBlue® filter maintenance**

 **NOTE**

**This operation requires the intervention by a trained maintainer.**

Refer to DIECI Technical Support Service.

The AdBlue® filter is located inside the pump of the urea system, under the cover "1" (fig. 170110-1).

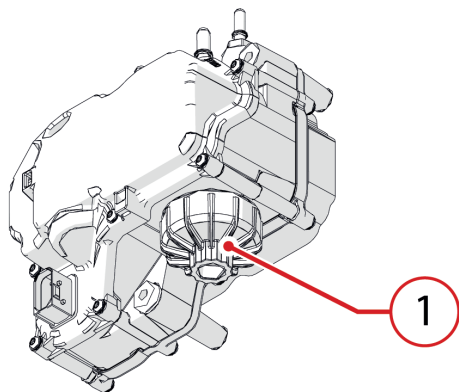

Figure: fig. 170110-1

**7.24.2.3 - FPT Series N Stage V engine errors list**

 **NOTE**

In case the vehicle is in error, contact a *Dieci* service center to solve the problem, indicating the error code reported.

For more information about the errors display, refer to the "Central instrument panel" chapter.

**7.25 - DPF - Particulate filter regeneration**

The ATS (After treatment System) consists of 3 different processes that can lead to an increase in the minimum rpm (Low Idle Up).



**• HC Accumulation**

To reduce the hydrocarbon accumulation, the engine control unit applies an increase in the Low Idle value from 850 rpm to 1,300 rpm; this strategy depends on receiving the Safe State signal from the vehicle control unit.

When the operator:

- Holds the joystick to perform boom movements;
- Removes the parking brake;
- Moves the vehicle.

The Low Idle value returns to its default value (850 rpm) and then increases again when the Safe State signal is received.

**• DPF Automatic Regeneration**

To reduce the particulate accumulation in the DPF, the engine control unit applies an increase in the Low Idle value from 850 rpm to 1,300 rpm; this strategy does not depend on receiving the Safe State signal from the vehicle control unit.

**• DPF Manual Regeneration**

To reduce the particulate accumulation in the DPF, if the automatic regeneration was not enough (DPF = 2 shown on the display), the operator can request a manual regeneration by using the corresponding button. This strategy depends on receiving the Safe State signal from the vehicle control unit. Therefore, when the operator:

- Holds the joystick to perform boom movements;
- Removes the parking brake;
- Moves the vehicle;

regeneration stops (**situation to be avoided until regeneration has been completed!**)

 **NOTE**

**During this operation it is strongly recommended not to leave the vehicle unattended**

## 7.26 - Cameras \*



### NOTE

**Cameras are part of an optional attachment.**

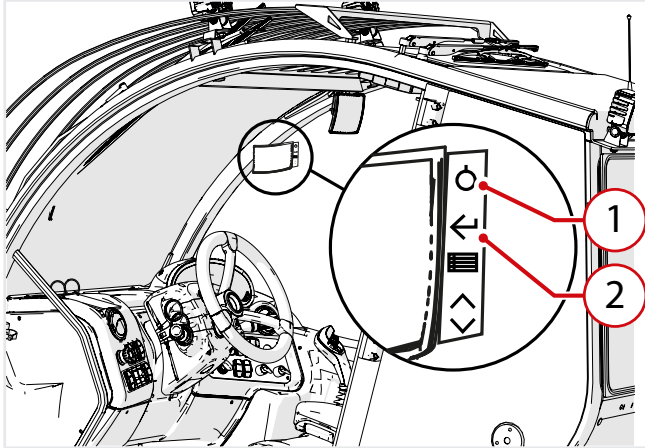

The cab includes a display for cameras that can be installed on the vehicle.

To turn on the display, press the “1” button.













If more than one camera are installed, pressing the “2” button switches from one camera to the other one.





**NOTE**

The vehicle is supplied with the equipment useful for the vehicle use and maintenance.

	<p><b>Tool bag</b> The tool carrier bag is made up of:</p>
	<p>Socket wrench</p>
	<p>Set of wrenches</p>
	<p>Screwdriver</p>
	<p>Lubricator</p>
	<p>Set of rubber plugs for quick couplings</p>
	<p>Rod for emergency recover pump (Only with man basket prearrangement)</p>
	<p>Adaptor cable for engine diagnostics (Only FPT engines Stage IIIB/Tier 4i version and following)</p>
	<p>Protruding load signal (only Italy)</p>
	<p>Rotating light</p>
	<p>Pin for vehicle tow hitch</p>
	<p>Pin for trailer hitch (only tractors)</p>

## 9.1 - General warnings on equipment use



### DANGER

It is strictly forbidden to modify the structure of the equipment or adjust the safety devices of the various tool components.

- Only Equipment CE certified by the relative manufacturer can be used on **DIECI** vehicles, as well as equipment approved or falling within the technical limits set out by **DIECI S.r.l.** The guarantee is void if not approved equipment is used.
- The Tool does not require CE certification.
- **DIECI S.r.l.** liability shall not be involved if equipment use or modifications do not comply with the above mentioned requirements.



### ATTENTION

**The equipment installed on the vehicle may only be used:**

- a) on consistent ground and with vehicle level with maximum tilt of 2°.
  - b) by competent and qualified personnel who must have read this manual. In the case of road use refer to the Use and Maintenance Manual of the vehicle making sure that the operator is in possession of a valid driver's license in accordance with the laws in force in the country of use (license B or higher for ITALY), and that the vehicle boom is in the fully retracted position.
- Some equipment be accompanied by instructions related to safety standards, connection and disconnection, operation and maintenance. Carefully read and fully implement these instructions prior to installation, use and maintenance of the equipment. In case of doubt, contact your local dealer.
  - Before starting to use the vehicle and related equipment, or before performing particularly complex or dangerous operations, it is absolutely necessary to practice in a clear work area free from obstructions.
  - In case of poor visibility of the zone use a person on the ground to coordinate the movements and operations and that monitors the area inviting people who might come, to go away. The

individual on the ground must stand at a safe distance from the vehicle in motion and alert, before any movement, any personal around.

- To prevent damaging hydraulic fittings when changing an equipment, stop the engine and wait a few seconds to remove pressure from the circuit. Always clean the fittings before their reinsertion.
- Check the cleanliness, protection and conditions of quick release joints in the equipment circuits and on the boom head daily.



### DANGER

Never carry the equipment in the vicinity of an open flame.



### DANGER

**When using the vehicle, carefully follow the respective Load charts.**

It is strictly prohibited to work without the respective load charts for the type of vehicle and installed equipment.

- The indications given by the anti-tipping system of the vehicle must be considered valid for standard working conditions, on flat and solid ground with well-operating and properly calibrated equipment. In any case, the values indicated by the load charts must be respected and never exceeded.
- It is mandatory, every time the equipment is used to insert the safety plugs to secure the equipment to the Attachment holding plate.
- If an attachment holding plate different from the original Dieci attachment holding plate is installed on the vehicle, a residual load will remain on the anti-tipping device of the vehicle as a safety factor.
- Refer to the manual of the manufacturer of the attachment holding plate installed if different than the original Dieci attachment holding plate.



### ATTENTION

**When moving the vehicle with equipment or man baskets installed, maintain a speed appropriate to the type of ground.**

When driving on rough terrain it is advisable not to exceed 10 km/h (6,2 mph) to prevent vibration and pitching phenomena, damaging the equipment or the man basket installed on the vehicle.



## WARNING

**It is possible that in certain working conditions there is no interference between the attachment holding plate and/or the equipment and the vehicle chassis or wheels.**

Pay due attention to prevent damage to the vehicle. Lift and extend the boom just enough to avoid interference.

### 9.1.1 - Equipment pre-use checks



## NOTE

Refer to the pre-use safety procedures of the vehicle on which the equipment is installed.

Before every use and every time new equipment is installed on the vehicle:

- Check that the equipment is properly hooked to all the pins and the hooks are inserted in the correct position.
- There is no damage, deterioration, deformation of the equipment locking components.
- Check that the equipment and components are intact, perfectly operating and not damaged.
- Verify that the equipment capacity is more than the weight of the load to be moved.
- Verify the correct operation of the equipment and of the controls present in the vehicle cab on which the equipment is installed in a work zone free from personnel and obstacles.
- Verify the operation of all indicators and lights present inside the vehicle on which the equipment has been mounted.
- Check the tilting when empty.
- Check the oil level in the hydraulic circuit.
- Check that the safety symbols and stickers are clearly legible.
- Check the efficiency and operation of the safety devices.
- Visually check the state of welding, inspect the vehicle and check for cavities, cracks of the welding or base metal or other inconveniences.
- Check for any deformations and/or modifications of the material due to sudden temperature changes or damage from impacts.
- Check the equipment for wear.
- Verify the use mode relating to the installed equipment has been set on the vehicle.

- Verify that the Load charts relating to the vehicle and installed equipment are present on the vehicle.

In case of equipment with hydraulic connections:

- Check that the pipes are in good conditions and do not obstruct the movements of the boom or of the equipment.
- Verify the correct connection of the hydraulic pipes (if present) ensuring that the equipment functions are not inverted.

In case of equipment with electrical connections:

- Check that the cables are in good conditions and do not obstruct the movements of the boom or of the equipment.
- Clean and fasten all the electrical connections (if present). Before each working shift, check there are no loose, twisted, hardened or damaged electrical cables. Do not operate the operating vehicle if there are any loose, twisted, hardened or damaged electric cables.

In the event of radiocontrol pre-arrangement:

- Refer to the specific manual of the equipment for further checks.
- Verify the correct operation of the radiocontrol/push button control panel and the charge status of the batteries.

In case lifting equipment is used

- Refer to the specific manual of the equipment for further checks.
- Verify the integrity of the lifting hook, including relative catch, and of the hook bolt to the rope.

In case winches are used

- Refer to the specific manual of the equipment for further checks.
- Check that the rope is not damaged, cut, torn, frayed. On the contrary, do not use the equipment and replace it. Check the operation of the limit switches, which must lock the rope according to the procedure described in the specific manual.
- Verify the operation of the extensometric transducer of the mounted equipment (if present); to do this, try to lift a load slightly heavier than the nominal maximum capacity of the equipment. In case the equipment is unable to lift the load, the transducer operates correctly,

otherwise immediately interrupt the operation bringing the load to the ground and repair the equipment.

### In case of using elevating work platforms

- Refer to the specific manual of the equipment for further checks.
- Verify the operation of the emergency button of the load limiter and of the area limiter at the beginning of each work cycle.
- Before using the platform ensure it is not wet, dirty with grease, oil, has icy surfaces or covered with other substances that can make its surface slippery. On the contrary, accurately clean and dry the platform surfaces. Danger of slipping and falling.
- The vehicle on which the equipment is installed must be braked and stabilized on solid ground. If outriggers (optional) are present, position them correctly on the ground before starting to operate.
- Before operating, make sure that the openings for access to the platform are in the closed position; always verify the correct engagement of the safety harnesses (PPE category III).



### ATTENTION

**All checks must be carried out by adequately trained personnel and registered on the control log.**

If damage or malfunctioning is detected, comply with the instructions contained in this manual or in the manual of the equipment or basket or contact the DIECI Assistance Center to agree the actions to be taken.

If routine or extraordinary maintenance or technical adjustment of the equipment is required, contact exclusively personnel authorized by the DIECI Assistance Center and note the service intervention on the control log.

If the equipment is tampered with, the guarantee is voided and the Manufacturer is relieved of all liability.



### DANGER

Operators who note anomalies on the equipment or on the vehicle on which it is installed, and it does not conform to safety regulations must suspend use and immediately inform the Person in charge.



### NOTE

For road circulation, refer to the Use and Maintenance Manual of the vehicle on which the equipment is installed.

## 9.1.2 - Bucket warnings



### WARNING

**Pay special attention to the following indications on how to use the vehicle with a bucket.**

- We recommend a limited and occasional use of the vehicle with bucket.
- Intensive use can damage the boom, so maintenance intervals should be halved.
- It is forbidden to push the bucket against the material with the extension movement.
- When pushing with the bucket against the material it is necessary to:
  - Keep the wheels straight;
  - Keep the boom closed;
  - Lower between the two chassis guides (if present);
  - Do not push the boom down lifting the two front wheels;
  - Do not excavate with the bucket
- It is forbidden to use buckets larger than those specified in the price list.
- It is forbidden to use buckets that are not "DIECI", in case you want to use buckets that are not "DIECI" contact the customer service.
- It is permitted to use the vehicle with the bucket only for carrying work.



### ATTENTION

**It is important that there is always visibility by the operator on the bucket work area. A bucket that is too large limits the operator's visibility and can damage the vehicle.**

## 9.2 - Equipment installation procedure

To properly install equipment carry out the following operations (fig. 150507-1):

1. Remove the safety pin "2" (if installed) by removing the safety plug "1".
2. Place the equipment on a flat not yielding surface, to be able to smoothly engage it with the attachment holding plate of the vehicle.
3. Place the vehicle with the boom lowered parallel to the tool. Approach the attachment holding plate to the accessory extending the telescopic boom. The vehicle can not extend the boom if it is completely lowered. Slightly raise the boom to be able to extend it.
4. Using the tilting movement, rotate the attachment holding plate downward. Bring the top of the plate under the locking hooks of the tool.
5. Slightly lift the boom and rotate the attachment holding plate upwards, thus making the equipment adhere to the attachment holding plate of the vehicle. During this operation, make sure that no person is in the vicinity of the equipment or the vehicle boom.
6. Turn off the engine and get out of the vehicle.
7. Insert the safety pins "2" in their seats on the attachment holding plate, passing through the corresponding slots of the equipment. In the case the two holes do not match, perform the steps described in chapter "Safety pin outline"
8. Fit the safety plug "1" on the pins just inserted.
9. In the event that the equipment needs electrical or hydraulic connections, refer to the "Hydraulic pipes connection" and "Electrical cables connection" chapters.
10. Once properly fixed the equipment, turn on the vehicle and set the correct mode of operation of the vehicle related to the newly installed equipment:
11. Consult the use and maintenance manual of the vehicle to set the correct mode of use.
12. Check that in the cab there is the load chart related to the vehicle and to the equipment just installed.

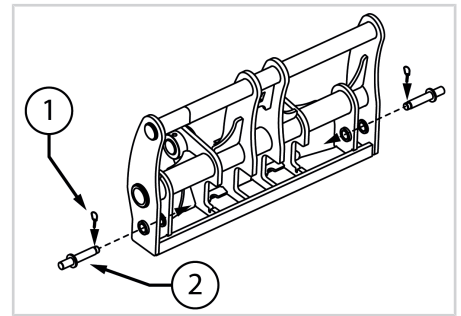

150507-1

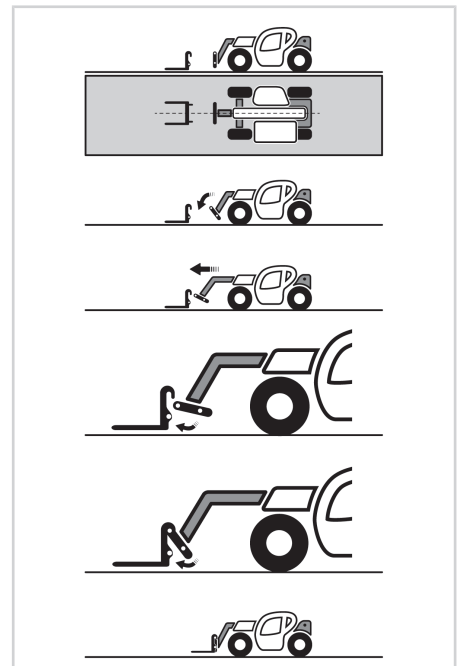

150507-2



### DANGER

In case, for deformation, the pin and the related safety pin do not reach the required position, it is absolutely forbidden to use the accessory as it may come off and fall to the ground dangerously.



### DANGER

It is forbidden to operate without the safety pin installed on the attachment holding plate.

**WARNING**

When using an equipment that has electrical or hydraulic connections these must always be correctly connected to the vehicle. Failure to connect does not allow the proper operation of the safety devices with risk of damage to property and persons and risk of vehicle tipping.

**DANGER**

It is forbidden to operate with a mode of use of the vehicle not suitable for the type of equipment installed. The electro-hydraulic equipment will not work correctly and safety devices will not be in operation creating a risk of damage to property and people and the vehicle risk of tipping.

**DANGER**

**It is forbidden to operate without the proper load chart related to the vehicle and to the equipment installed.**

For more details on the accessory installation procedures or warnings, consult the use and maintenance manual of the accessory.

**ATTENTION**

**Before each use, check that:**

- a) The equipment is properly hooked to all the pins and hooks are inserted in the correct position.
- b) There is no damage, deterioration, deformation of the equipment locking components
- c) If present, the electric cables or hydraulic pipes are in good condition and do not create hindrance while using the equipment
- d) The mode of operation of the vehicle is consistent with the type of equipment installed
- e) In the cab there are the load charts related to the vehicle and to the equipment installed.

**9.2.1 - Counterplate for Hercules 130.10**

Only for vehicles approved for Italy, in order to run on public roads, a counterweight "1" must be installed on the fork holding plate "2" in order to lighten the rear axle.

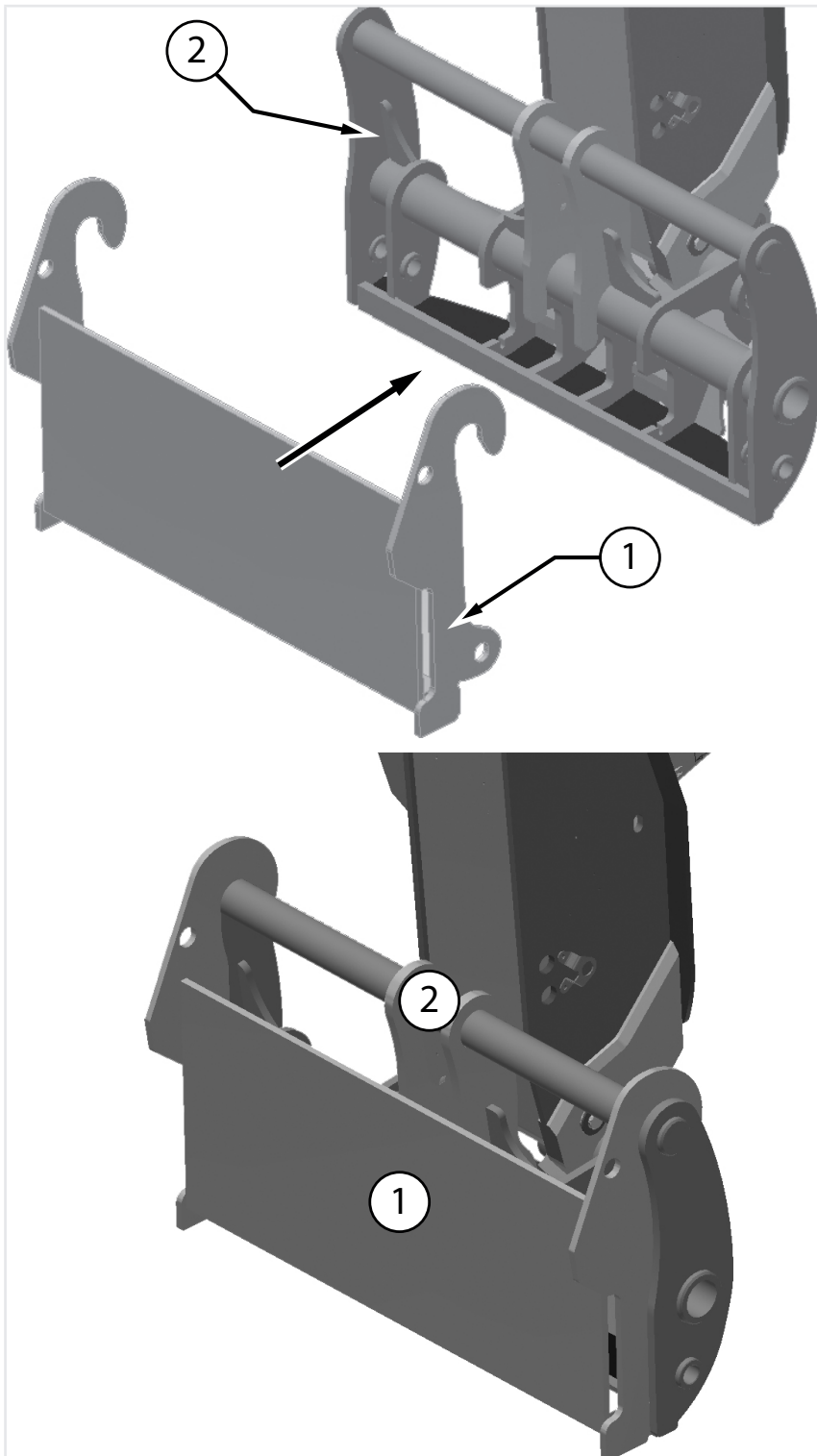

## 9.3 - Hydraulic connections

### 9.3.1 - Warnings for hydraulic connections



#### NOTE

Before making the hydraulic connections, perform the "Equipment installation procedure" and check the equipment is correctly fixed to the vehicle.

Check the hydraulic pipes do not obstruct the movements of the vehicle or of the equipment as it may be damaged.

Consult the equipment manual to verify correct operation.



#### WARNING

When using an equipment that has electrical or hydraulic connections these must always be correctly connected to the vehicle. Failure to connect does not allow the proper operation of the safety devices with risk of damage to property and persons and risk of vehicle tipping.



#### NOTE

Always accurately clean the hydraulic connections before each coupling. If not used, both the hydraulic connections must be protected with adequate plastic caps.



#### WARNING

Do not use the vehicle or the equipment if the hydraulic pipes are worn or damaged, but repair or replace them.



#### WARNING

**Once the hydraulic connections have been made, it is compulsory to verify that the controls are consistent with the operations carried out on the vehicle.**

By inverting the connections, the accessory functions may be inverted compared to normal use, therefore, after having completed the equipment installation procedure, test the various functions in a free zone.



#### DANGER

#### Hydraulic liquid under pressure

Fine jets of hydraulic oil at high pressure can penetrate the epidermis. Keep hands and face at a safe distance from the pressurized fluid and wear goggles and protective gloves. Bring a piece of cardboard to the area of the suspected leak and then check for traces of liquid on the cardboard. If the liquid penetrates the skin immediately seek for medical advice.



#### DANGER

#### Hydraulic pressure

The leakage of hydraulic oil at operating pressure can cause injury: before connecting or disconnecting the hydraulic pipes, release the residual pressure from the hydraulic circuit. Prevent starting the engine with disconnected pipes.

### 9.3.2 - Type of hydraulic quick couplings

The hydraulic quick couplings at boom head can be of two types:

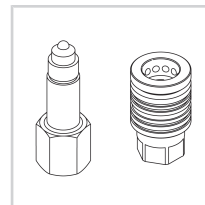

Push-Pull (fig. 150509-1)

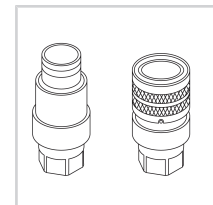

Flat-Face (fig. 150509-2)

### 9.3.3 - References for correct connection

To make the correct connection of the hydraulic fittings, each hydraulic plug or socket is marked with a color or symbol.

- The **red** plugs must be connected to the **red** sockets or those with the "+" mark.
- The **blue** plugs must be connected to the **blue** sockets or those with the "-" mark.



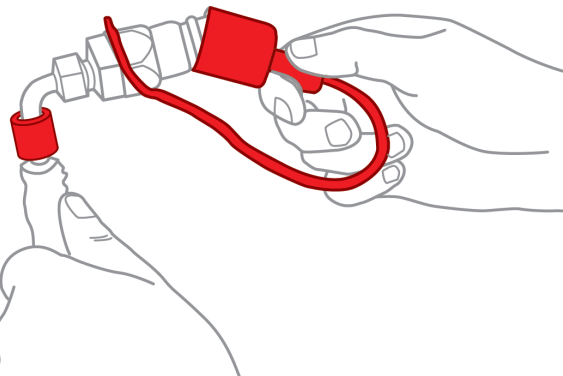

Figure: Cap and mark on the hydraulic sockets

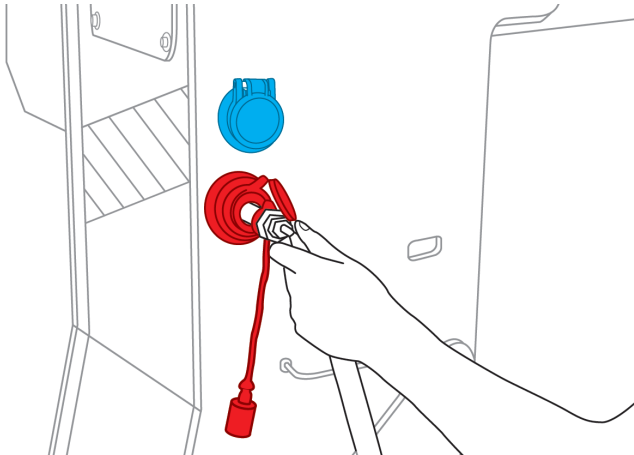

Figure: Hydraulic sockets on boom head

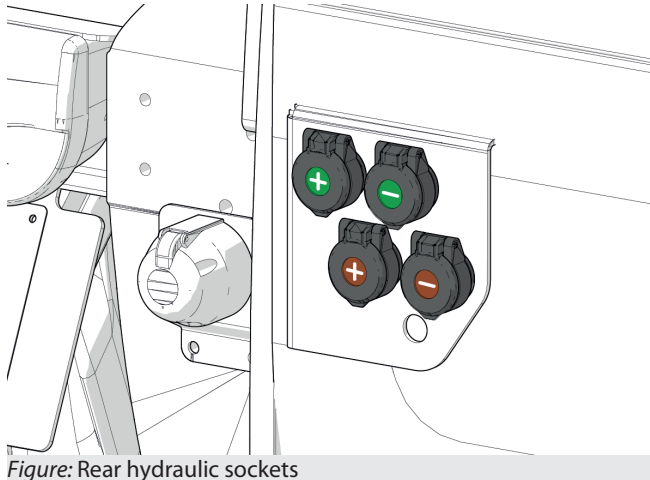

Figure: Rear hydraulic sockets



**WARNING**

**Equipment with hydraulic connections made incorrectly have movements or functions that do not agree with the operator's controls and can cause damage to other operators, material handled or to the vehicle and equipment.**

Always make sure that the hydraulic connections follow the indications given above for proper connection and that the movements and functions of the equipment comply with the operator controls.

**9.3.4 - Push-Pull couplings connection**

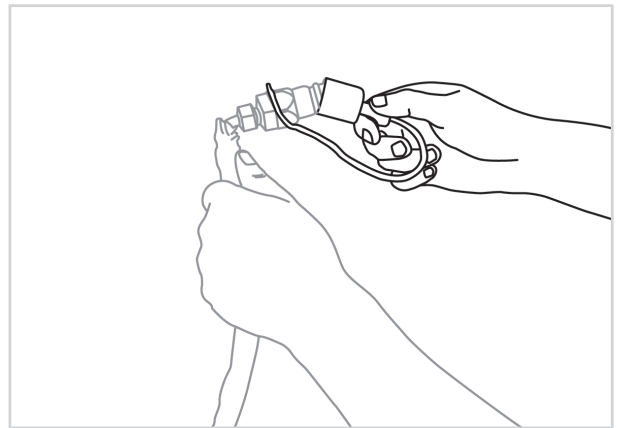

150510-1

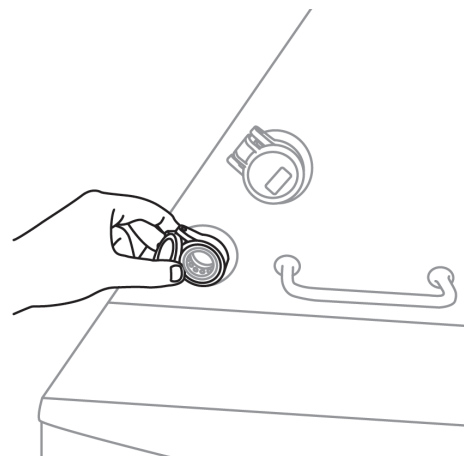

Figure: 150510-2

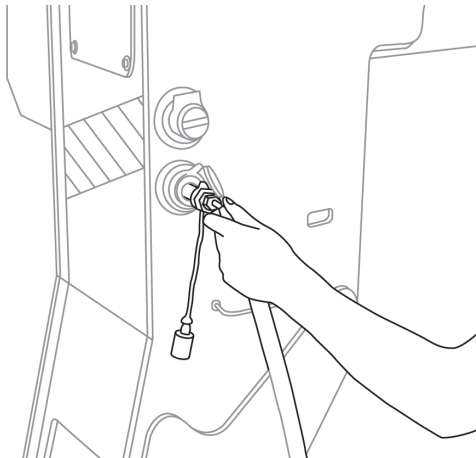

Figure: 150510-3

To connect the Push-Pull quick couplings to the sockets on the boom head:

1. Perform the equipment installation procedures described in the chapter: "Equipment installation procedure".
2. Turn off the vehicle.
3. In case of closed center distributor, discharge the system residue pressure (refer to chapter Closed center distributor: Release the pressure through the Pressure relief button \* [▶ 140]).
4. Remove the protection cap from the equipment hydraulic plugs (fig. 150510-1).
5. Lift the protective cover for the hydraulic socket present on the boom head (fig. 150510-2).
6. Clean the plug and socket, if soiled.
7. Fit the plug inside the socket and press until the pipe is blocked (fig. 150510-3).
8. Check that the hydraulic pipe is correctly fixed.
9. Carry out the same operation for both pipes.



## NOTE

Consult the equipment manual to verify correct operation.

### 9.3.4.1 - Push-Pull couplings connection when connected to a valve

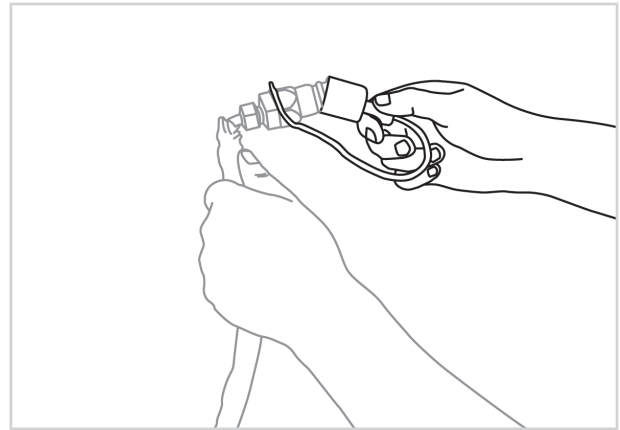

150511-1

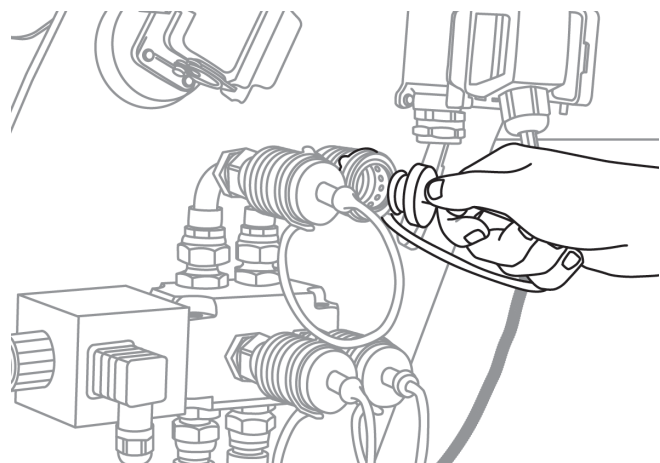

Figure: 150511-2

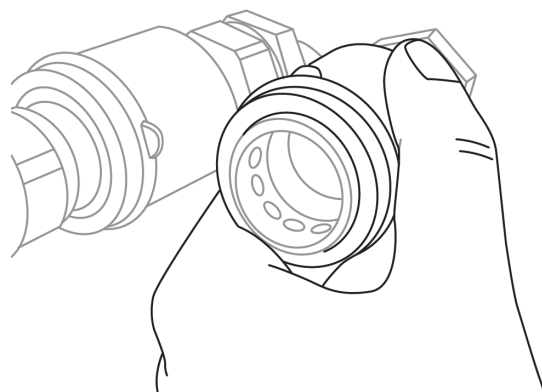

Figure: 150511-3

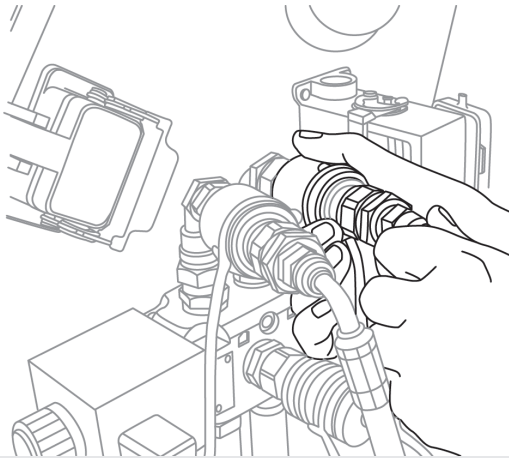

Figure: 150511-4

To connect the Push-Pull quick couplings to the valve on the boom head:

1. Perform the equipment installation procedures described in the chapter: "Equipment installation procedure".
2. Turn off the vehicle.
3. In case of closed center distributor, discharge the system residue pressure (refer to chapter Closed center distributor: Release the pressure through the Pressure relief button \* [▶ 140]).
4. Remove the protection cap from the equipment hydraulic plugs (fig. 150511-1).
5. Remove the protection cap from the hydraulic sockets installed in the valve on the boom head (fig. 150511-2).
6. Clean the plug and socket, if soiled.
7. Push the ring on the valve socket towards the boom (fig. 150511-3).
8. Place the plug fully inside the socket and release the ring of the valve (fig.150511-4).
9. Check that the hydraulic pipe is correctly fixed.
10. Carry out the same operation for both pipes.



**NOTE**

Consult the equipment manual to verify correct operation.

**9.3.5 - Flat-Face couplings connection**

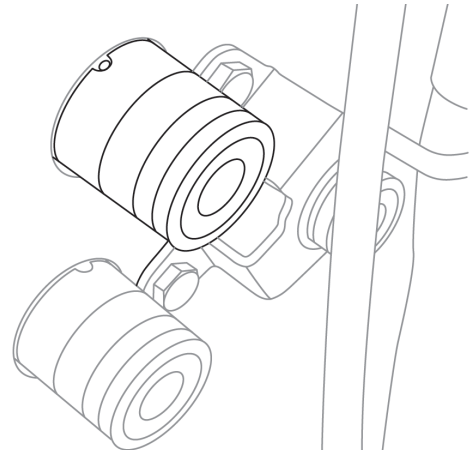

Figure: 150512-1

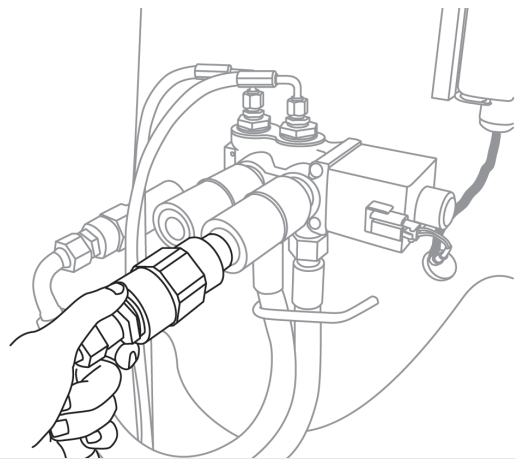

Figure: 150512-2

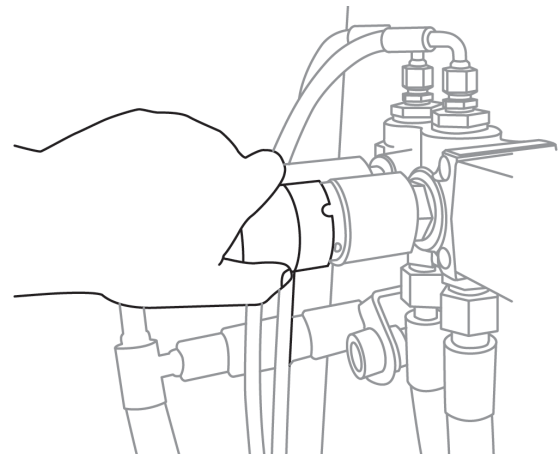

Figure: 150512-3

To connect the Flat-Face quick couplings:

1. Perform the equipment installation procedures described in the chapter: "Equipment installation procedure".
2. Turn off the vehicle.

3. In case of closed center distributor, discharge the system residue pressure (refer to chapter Closed center distributor: Release the pressure through the Pressure relief button \* [▶ 140]).
4. Clean the plug and socket, if soiled.
5. Rest the plug at center of the socket and push the fully plug (fig. 150512-2), until the socket ring is lifted.
6. Turn the ring to block the plug inside the socket (fig. 150512-3).
7. Check that the hydraulic pipe is correctly fixed.
8. Carry out the same operation for both pipes.



## NOTE

Consult the equipment manual to verify correct operation.

### 9.3.6 - Closed center distributor: Release the pressure through the Pressure relief button \*



## NOTE

This operation is possible and it may be required only for vehicles fitted with "Closed center distributor" and "Trailer descent".

Consequences

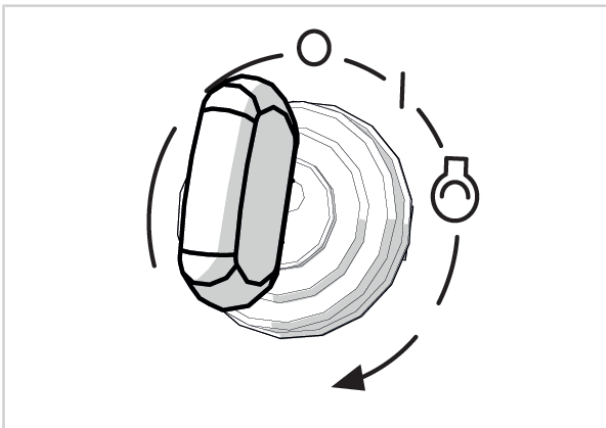

150501-1

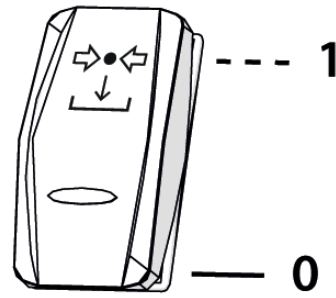

Figure: Pressure relief switch

To relieve pressure it is necessary to:

1. Move the ignition key of the vehicle to position "I" (fig. 150501-2).
2. Select the hydraulic socket still under pressure (if there is more than one hydraulic socket refer to the vehicle manual, chapter "Hydraulic sockets selection").
3. Press the "Pressure relief" switch to release the residual pressure of the selected hydraulic socket.
4. Proceed with the hydraulic couplers connection operation.

## 9.4 - Electrical Connections

### 9.4.1 - Warnings for electrical connections



## DANGER

**Before making the electrical connections, switch off the vehicle.**

Do not use the vehicle or the equipment if the electrical cables are worn or damaged, but repair or replace them.



## WARNING

Do not leave the boom plug hanging from the chain during work operations as this may be damaged impairing the vehicle correct operation when used without equipment.



## ATTENTION

Before making the electrical connection, perform the "Equipment installation procedure" and check the equipment is correctly fixed to the vehicle.



**WARNING**

When using an equipment that has electrical or hydraulic connections these must always be correctly connected to the vehicle. Failure to connect does not allow the proper operation of the safety devices with risk of damage to property and persons and risk of vehicle tipping.

Consult the equipment manual to verify correct operation.



**ATTENTION**

Check that the electrical cable is not in a position that hampers the movements of the operating vehicle and of the equipment as it could be damaged.

**9.4.2 - Procedure for connecting electrical connections**

The electrical connections on the boom head may be at 6 or 24-pole, but the connection procedure is the same for both.

For equipment provided with electrical system carry out the following operations:

1. Perform the equipment installation procedures previously described.
2. Turn off the vehicle.
3. Disconnect the cover from the socket on the boom "1" (fig. 150512-1) lowering the 2 safety levers "2".

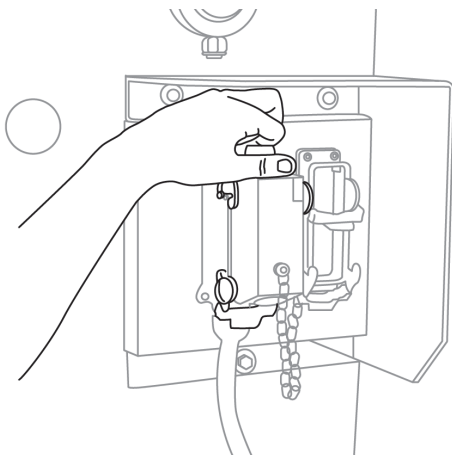

Figure: fig.150512-1

4. Remove the cover located on the boom socket and fit it in the dummy socket aside (fig. 150512-2) and fasten it with the appropriate levers.

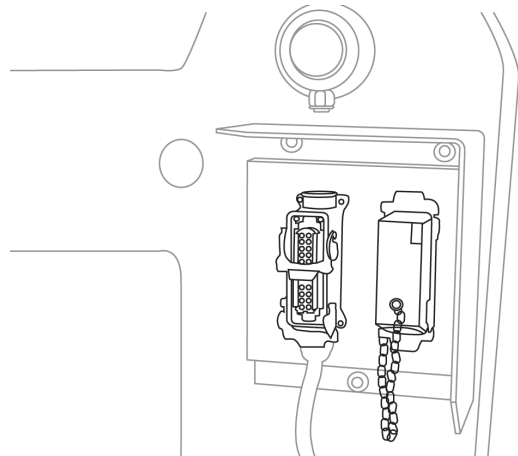

Figure: fig. 150512-2

5. Disconnect the plug from the dummy socket on the equipment "1" (fig. 150512-3) lowering the 2 safety levers "2" (fig. 150512-3).

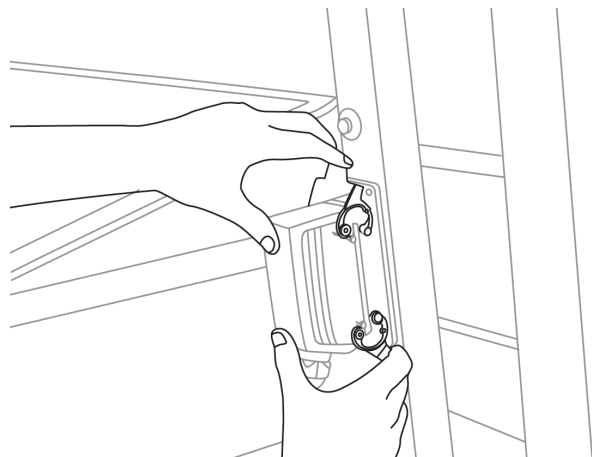

Figure: fig. 150512-3

6. Connect the plug of the equipment on the electrical socket of the boom, fastening it by lifting the 2 safety levers "1" (fig. 150512-4).

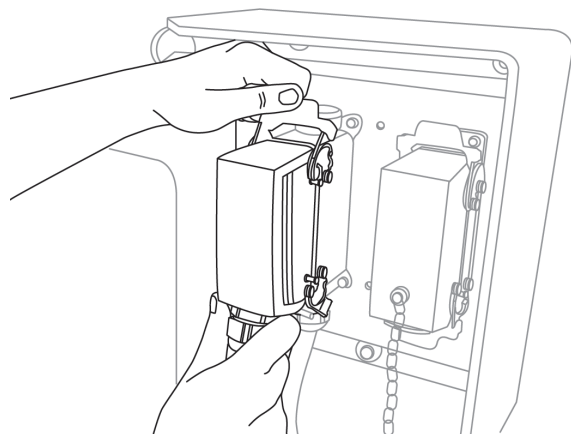

Figure: fig. 150512-4

7. Once the equipment is properly fixed, turn on the vehicle and set the correct mode of operation of the vehicle related to the newly installed equipment.

8. Check that in the cab there is the load chart related to the vehicle and to the equipment just installed.

## 9.5 - Equipment removal

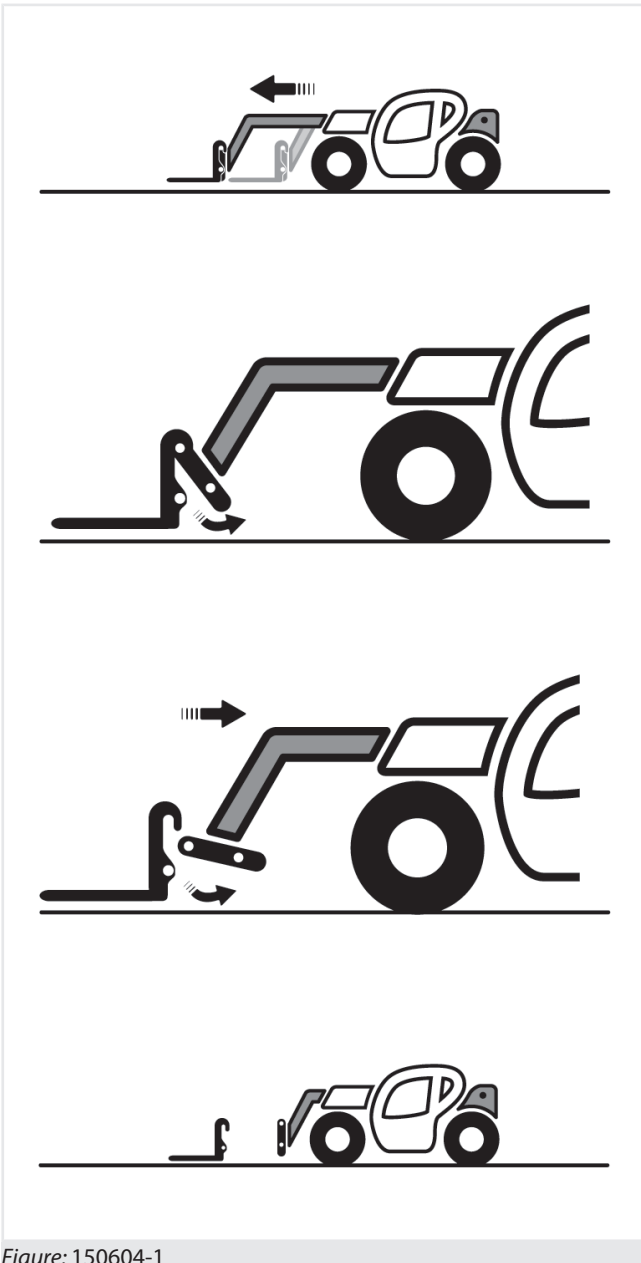

Figure: 150604-1

To store the accessory, once you finished using it, carry out the following operations:

1. Place the vehicle on a solid and level ground.
2. Position the equipment above a support platform to facilitate the handling and transportation of the single piece of equipment.
3. Lower and extend the vehicle boom of about one meter.
4. Turn off the engine.

5. Remove the electrical connections, if any (see the following chapter).
6. Remove the water connections, if any (see the following chapter).
7. Release the equipment following the reverse procedure of the equipment installation in accordance with the type of plate installed on the vehicle.
8. Turn on the vehicle and swing down in order to release the attachment holding plate from the equipment.
9. Once released the attachment holding plate, retract the vehicle boom.



### NOTE

The accessory placed on the ground must always be appropriately marked and barriers and clearances must be laid on all sides of the area that it could occupy falling.



### DANGER

**After releasing the system pressure always wait for a minute before disconnecting the joints.**

Always disconnect the hydraulic pipes and electrical cables of the equipment before releasing it from the vehicle. Otherwise it is possible to damage the pipes or cables and the tool may fall and be dragged.

### 9.5.1 - Electrical connections removal

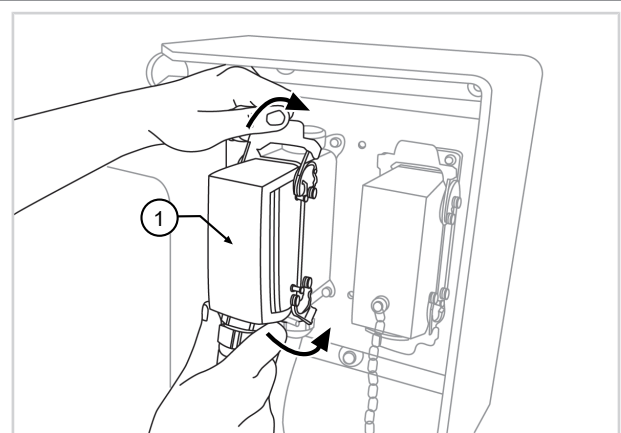

150514-1

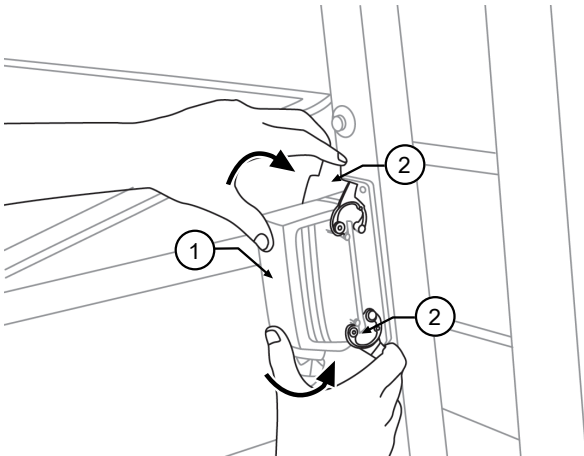

Figure: 150514-2

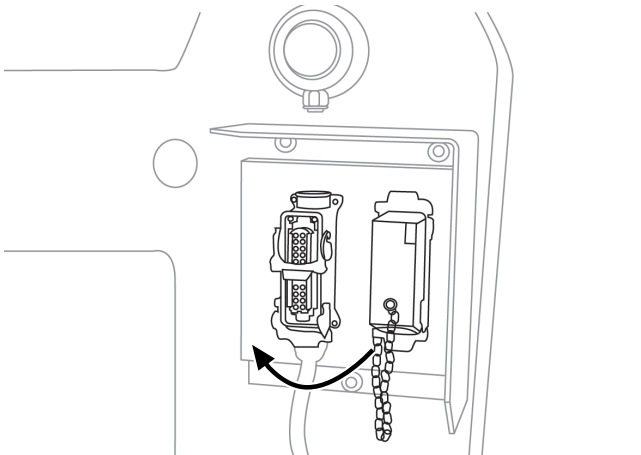

Figure: 150514-3

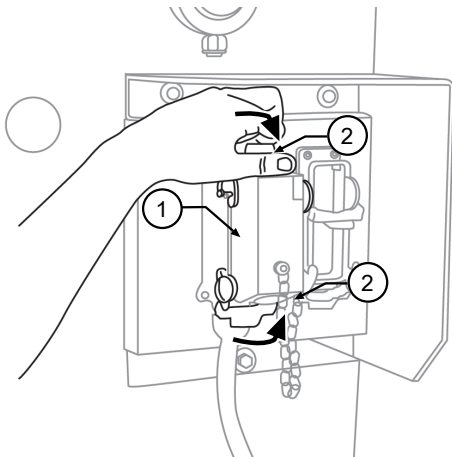

Figure: 150514-4

To remove the electrical connections from the equipment it is necessary to:

1. Follow steps 1, 2, 3 and 4 of the procedure to remove the equipment from the vehicle described in the previous chapter.
2. Disconnect the plug of the equipment from the boom lowering the two safety levers (fig. 150514-1).
3. Position the plug of the equipment on its dummy socket "1" (fig. 150514-2), fastening it with the safety levers "2".

4. Disconnect the cover located on the boom dummy socket and fit it in the electrical socket (fig. 150514-3).
5. Secure the cover to the socket on the boom "1" (fig. 150514-4) through the safety levers (fig. 150514-4).
6. Check that the electrical cables are not trapped in the attachment holding plate or that they can be crushed by the equipment when it will be placed on the floor.
7. Proceed with the subsequent operations to remove the equipment from the vehicle.

### 9.5.2 - Push-Pull couplings removal

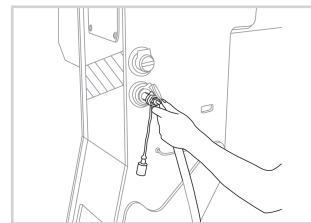

150513-1

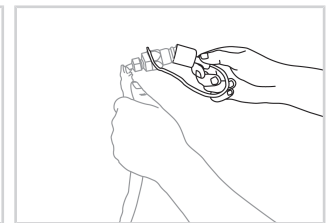

150513-2

To disconnect the Push-Pull quick couplings from the socket on the boom head it is necessary to:

1. Follow steps 1, 2, 3 and 4 of the procedure to remove the equipment from the vehicle described in the previous chapter.
2. If a closed center distributor is installed on the vehicle, carry out the procedures described in the chapter "Closed center distributor: Release the pressure through the Pressure relief button \* [► 140]" to release pressure in the hydraulic circuit.
3. Turn off the vehicle.
4. Pull the plug towards yourself to remove it from the socket (fig. 150513-1).
5. Clean the plug and socket, if soiled.
6. Fit the protection cap to the equipment hydraulic plugs (fig. 150513-2).
7. Carry out the same operation for both pipes.
8. Check that the hydraulic pipes are not trapped in the attachment holding plate or that they can be crushed by the equipment when it will be placed on the floor.
9. Proceed with the subsequent operations to remove the equipment from the vehicle.

### 9.5.2.1 - Push-Pull couplings removal when connected to a valve

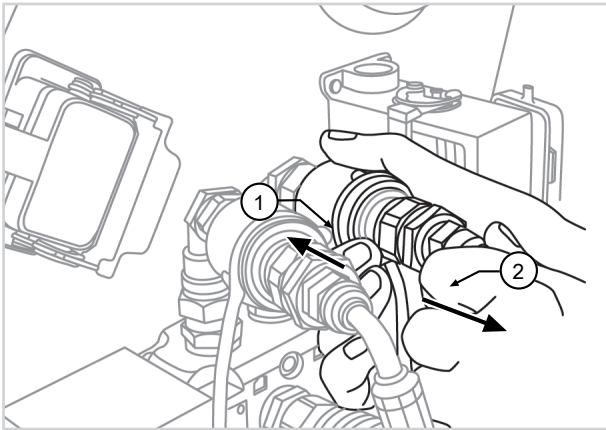

150515-1

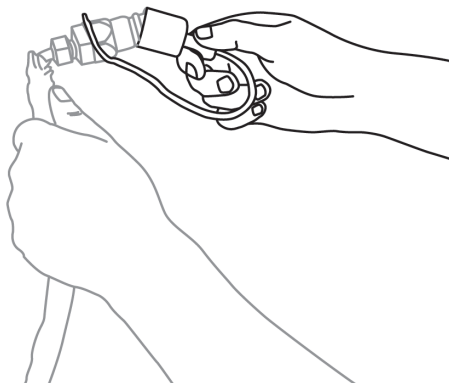

Figure: 150515-2

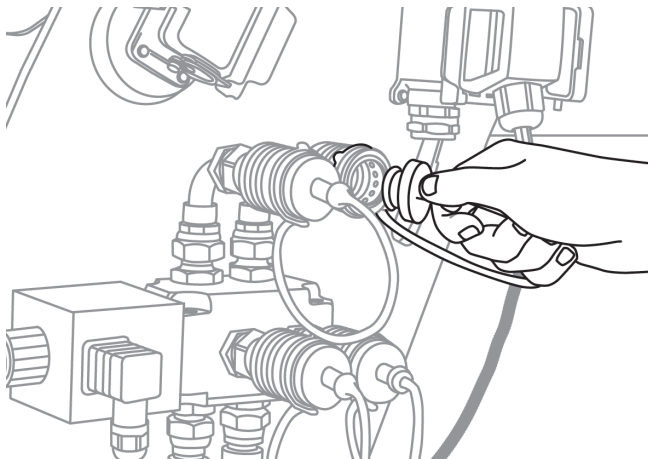

Figure: 150515-3

To disconnect the Push-Pull quick couplings from the valve on the boom head:

1. Follow steps 1, 2, 3 and 4 of the procedure to remove the equipment from the vehicle described in the previous chapter.
2. If a closed center distributor is installed on the vehicle, carry out the procedures described in the "Closed center distributor: Release the pressure

through the Pressure relief button \* [▶ 140]" chapter to release pressure in the hydraulic circuit.

3. Turn off the vehicle.
4. Push the ring of the socket towards the vehicle boom "1" (fig. 150515-1).
5. Pull the plug towards yourself to remove it from the socket "2".
6. Clean the plug and socket, if soiled.
7. Fit the protection cap to the equipment hydraulic plugs (fig. 150515-2).
8. Fit the protection cap to the hydraulic sockets of the valve (fig. 150515-3).
9. Carry out the same operation for both pipes.
10. Check that the hydraulic pipes are not trapped in the attachment holding plate or that they can be crushed by the equipment when it will be placed on the floor.
11. Proceed with the subsequent operations to remove the equipment from the vehicle.

### 9.5.3 - Flat-Face couplings removal

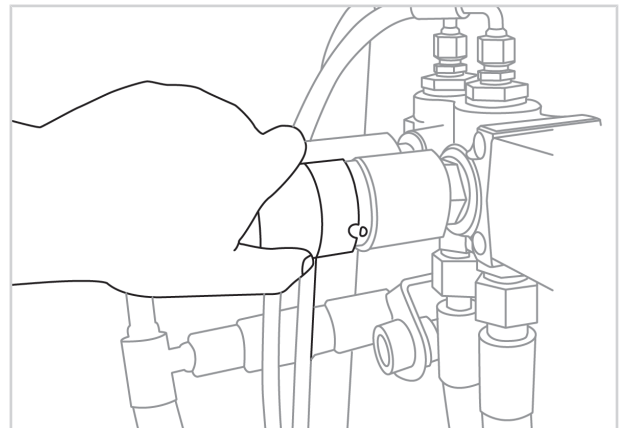

150516-1

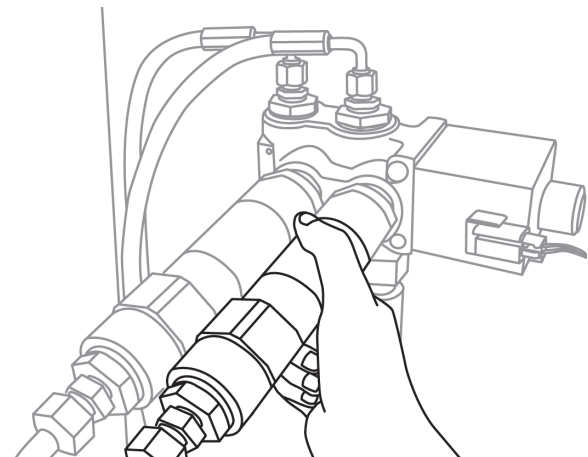

Figure: 150516-2

To disconnect the Flat-Face quick couplings:



1. Follow steps 1, 2, 3 and 4 of the procedure to remove the equipment from the vehicle described in the previous chapter.
2. If a closed center distributor is installed on the vehicle, carry out the procedures described in the "Closed center distributor: Release the pressure through the Pressure relief button \* [► 140]" chapter to release pressure in the hydraulic circuit.
3. Turn off the vehicle.
4. Turn the socket ring to match the recess with the position of the ball placed on the socket (fig. 150516-1).
5. Push the socket ring "1" (fig. 150516-2).
6. Pull off the plug "2" (fig. 150516-2).
7. Clean the plug and socket, if soiled.
8. Carry out the same operation for both pipes.
9. Check that the hydraulic pipes are not trapped in the attachment holding plate or that they can be crushed by the equipment when it will be placed on the floor.
10. Proceed with the subsequent operations to remove the equipment from the vehicle.

## 9.6 - Forks

### 9.6.1 - Identification

The term "Forks" means the pair of forks to be installed on the vehicle.

The purpose of this equipment is the lifting and handling of a load from the ground upwards, and vice versa.



#### NOTE

The forks may be provided with a spreader/shifter that allows to position the distance between the forks more quickly and safely.

The data necessary for the identification of the forks are positioned on the right side of the forks, in the upper part "A" (fig. 150518-1).

Below are the identification data (their order may be different on the forks).

To ensure a prompt and efficient service when ordering parts or when requesting information or technical clarification always specify the identification details.

Therefore we recommend to note the data relating to the accessory in your possession in order to safely and quickly identify them in the future, in case of need.

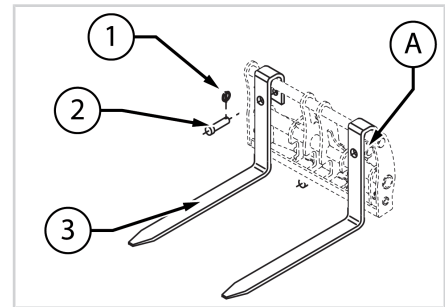

150518-1

<b>Dieci</b> forks code	.....
Manufacturer's Logo/ Abbreviation	.....
Manufacture Date/Batch	.....
Maximum capacity (Kg)	.....
Load application center of gravity (mm) *	.....

\* There may be more than one value depending on the load.

### 9.6.2 - Description

The forks (fig. 150519-1) consist of the following main components:

1. Lock pin
2. Fastening pin
3. Forks

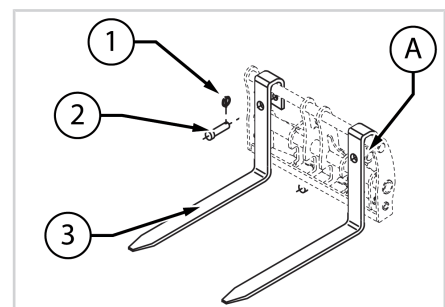

150519-1

**WARNING**

The equipment fastening hole located at the forks end can only be used for fastening certain equipment to the forks. For the fastening procedures refer to the manual of the equipment.

---

### 9.6.3 - Installation

The procedure for installing the forks is the same for installing the equipment, but the safety pins locking system is different.

To secure the forks to the attachment holding plate:

- Remove the snap pins "1" (fig. 150507-1) and the locking pins from the forks "2".
- Place the equipment on a flat not yielding surface, to be able to smoothly engage it with the attachment holding plate of the vehicle.
- Place the vehicle with the boom lowered parallel to the tool. Approach the attachment holding plate to the accessory extending the telescopic boom. The vehicle can not extend the boom if it is completely lowered. Slightly raise the boom to be able to extend it.
- Using the tilting movement, rotate the attachment holding plate downward. Bring the top of the plate under the locking hooks of the tool.
- Slightly lift the boom and rotate the attachment holding plate upwards, thus making the equipment adhere to the attachment holding plate of the vehicle. During this operation, make sure that no person is in the vicinity of the equipment or the vehicle boom.
- Turn off the engine and get out of the vehicle.
- Insert the safety pins "2" in their seats on the attachment holding plate, passing through the corresponding slots of the equipment. In the case the two holes do not match, perform the steps described in chapter "Safety pin outline"
- Fit the safety plug "1" on the pins just inserted.
- In the event that the equipment needs electrical or hydraulic connections, refer to the "Hydraulic pipes connection" and "Electrical cables connection" chapters.
- Once properly fixed the equipment, turn on the vehicle and set the correct mode of operation of the vehicle related to the newly installed equipment:
- Consult the use and maintenance manual of the vehicle to set the correct mode of use.
- Check that in the cab there is the load chart related to the vehicle and to the equipment just installed.

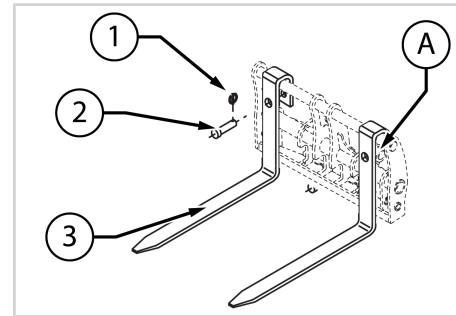

150507-1

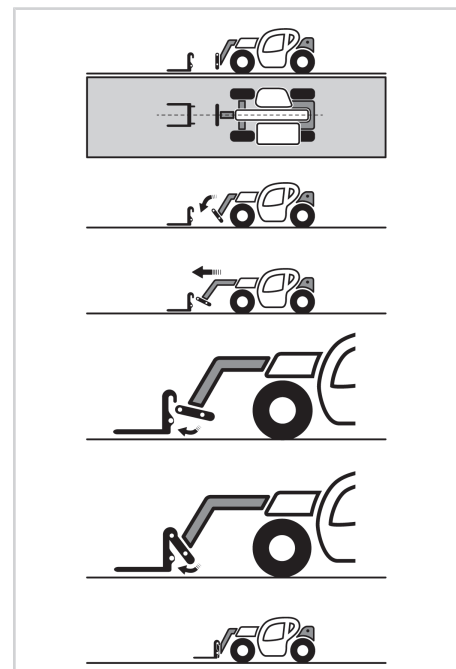

150507-2

## 9.6.4 - Forks check

**NOTE**

For the forks verification frequency refer to the "Control log".

**ATTENTION**

During maintenance and control, it is mandatory to use the appropriate Personal Protective Equipment.

**WARNING**

**It is absolutely forbidden to carry out maintenance on the forks (e.g. welding, drilling, engraving, etc ...).**

In the event of damage or deformation immediately replace the forks.

Check the forks thickness.

The maximum wear allowed is **10%** (fig. 150520-1).

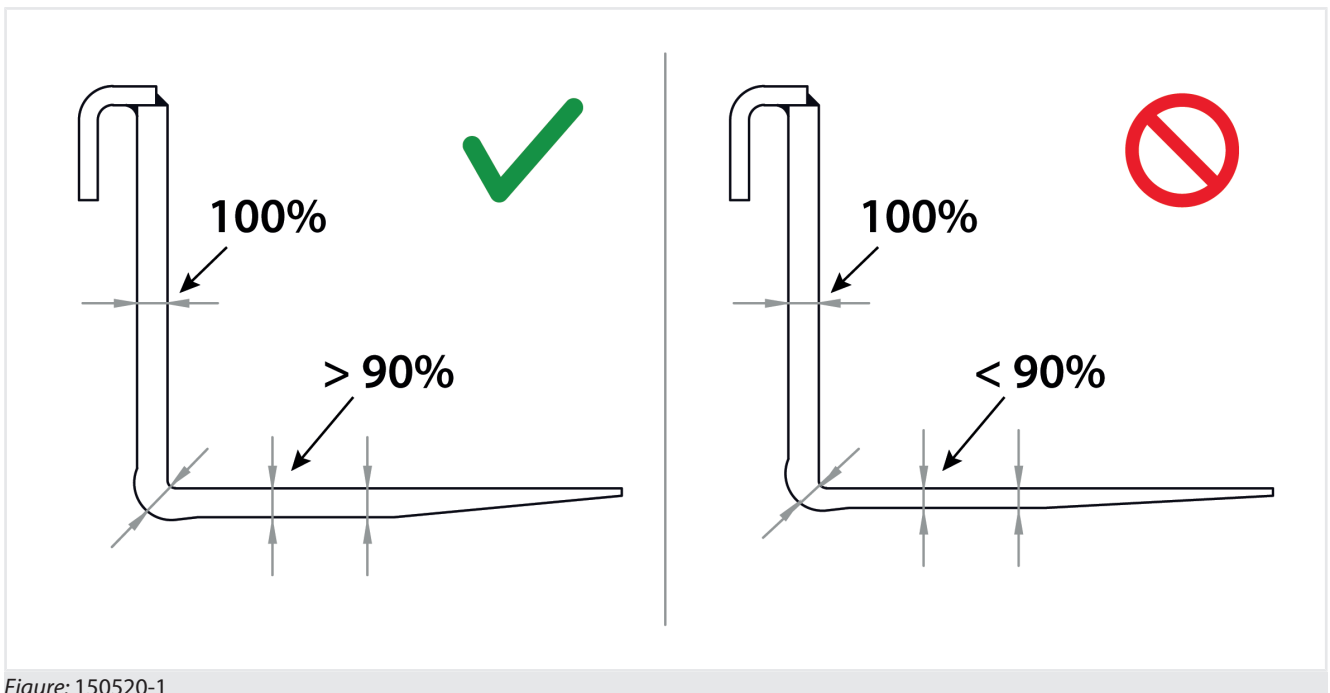

Figure: 150520-1

For example for a fork 70 mm thick, the thickness must not be less than 63 mm. ( $70 - 10\% = 63$ )

For a quick check of the thickness of the forks, it is necessary to measure the thickness in the vertical part of the fork "1" (fig. 150520-2); this will be the dimension to which refer for the fork thickness measurements "2" (fig. 150520-2). Make at least three measurements at several points.

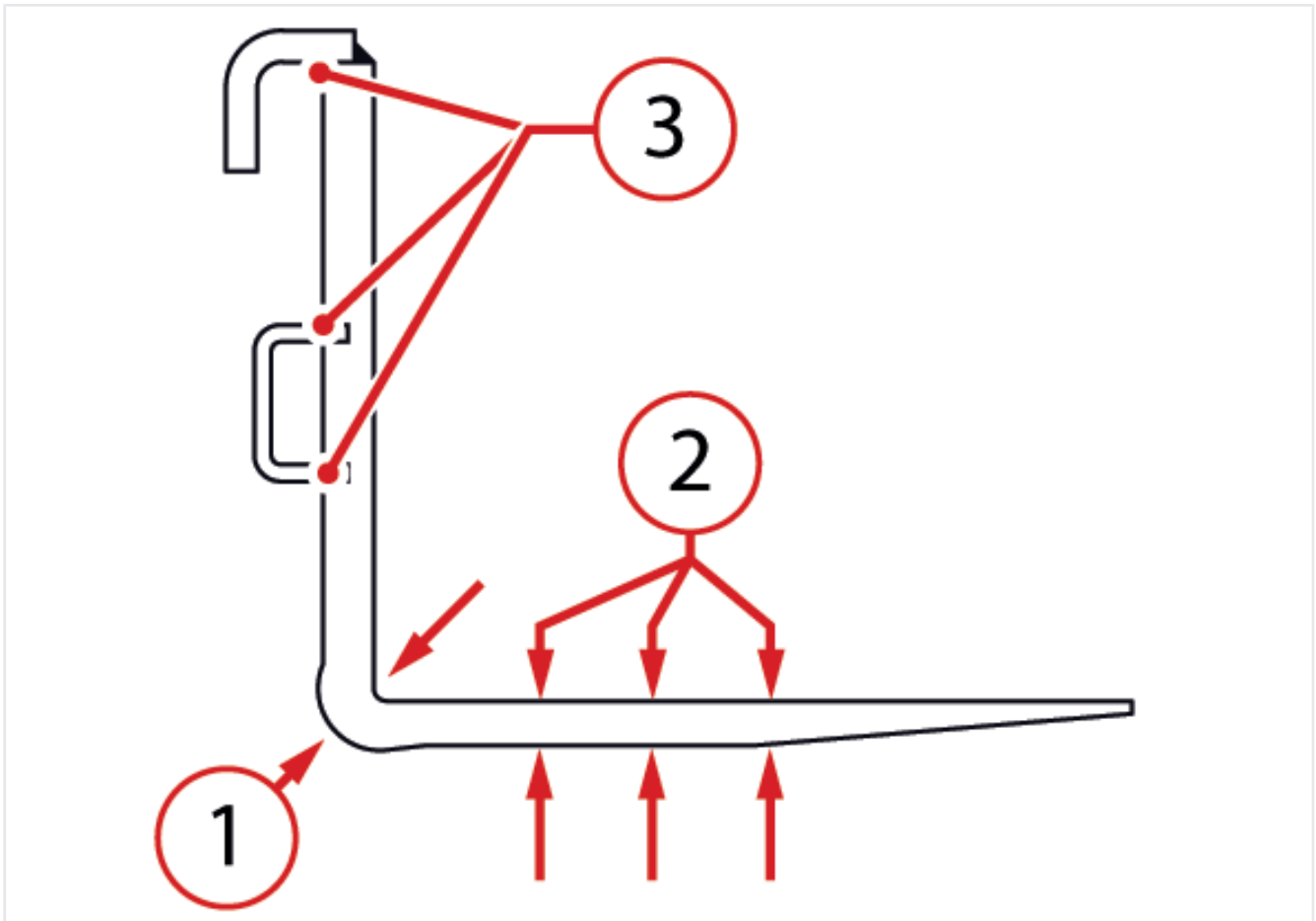

Figure: 150520-2

Verify the deformation of the forks

Verify that the two forks are parallel between them and that the distance from the ground is the same for both, or with difference of less than 3% of the length of the fork (fig. 150520-3).

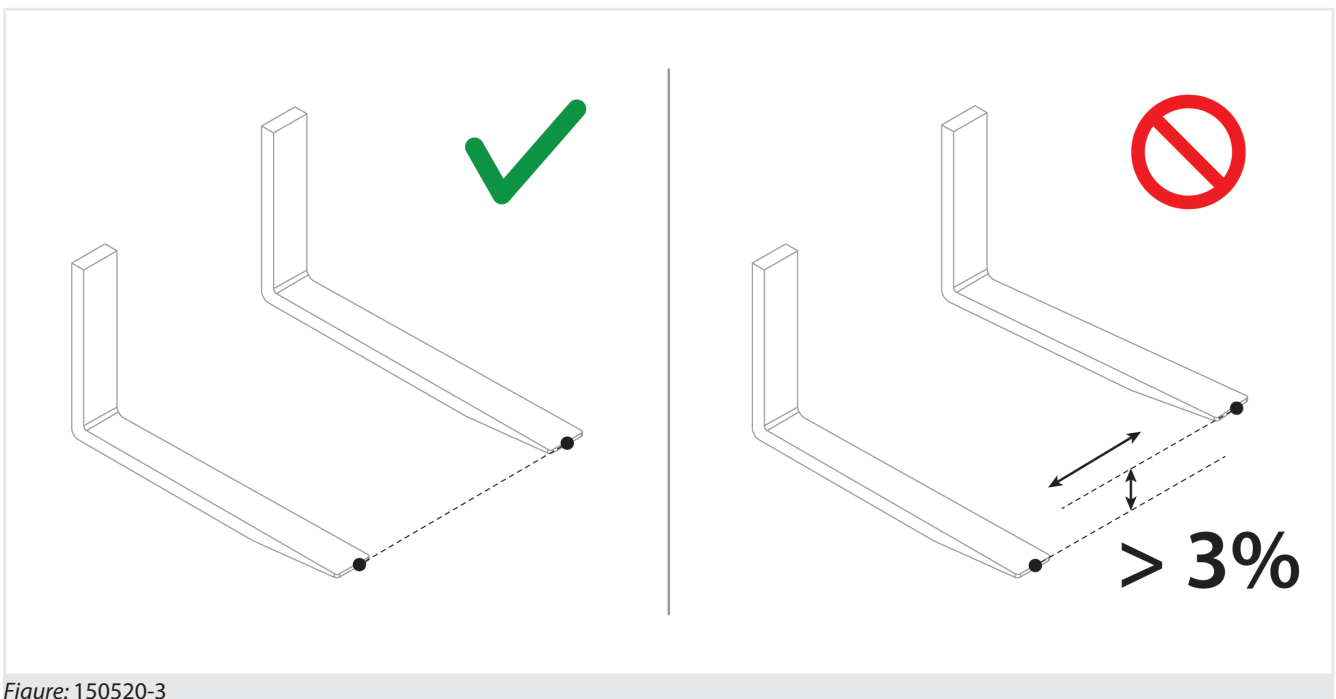

Figure: 150520-3

For example, for a fork 1800 mm long, the difference between the maximum permissible deformation of the fork tips will therefore be of 54 mm ( $1800 \times 3/100 = 54$ ).

### Check the integrity of the welds

Check that all the welds on the forks "3" (fig. 150520-2) are in good conditions and have no cracks or anomalies.

## 9.6.5 - Forks use



### ATTENTION

Before starting to use the equipment, inspect and test it as described in the section "Equipment pre-use check".



### WARNING

It is absolutely forbidden to use the forks or any type of equipment, without securing it to the attachment holding plate with the appropriate safety plugs.



### DANGER

**Before each use, check the wear status of the forks, they could be worn out and not hold the load to be handled creating a dangerous situation.**

Before starting to use the equipment, refer to the chapters:

- a) "Safety regulations"
- b) "Forks safe working procedures [▶ 155]"
- c) "Forks check [▶ 149]"

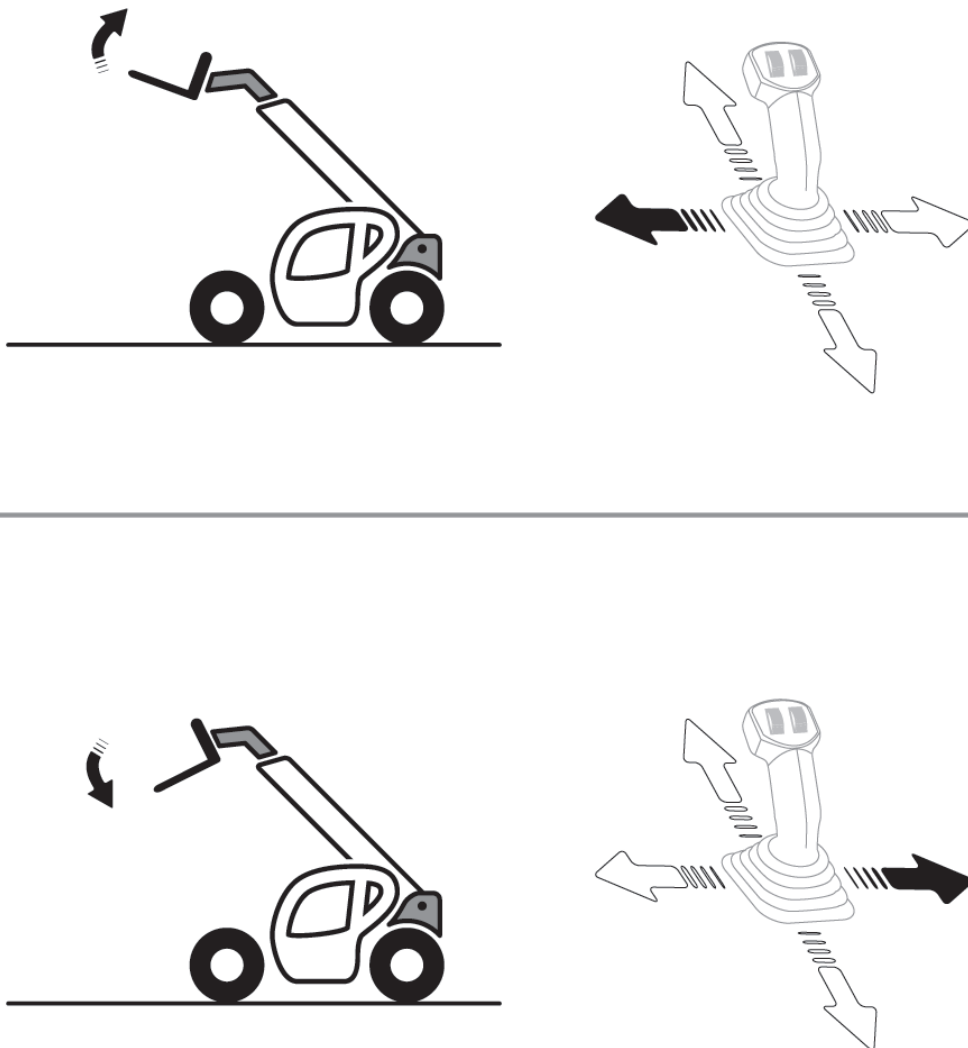

Figure: 150521-1

To use the forks it is sufficient to move the controls for the plate tilting.

By moving the joystick to the left, the tips of the forks will rise; by moving the joystick to the right, the tips of the forks will drop.

### 9.6.6 - Forks adjustment

To adjust the position of the forks it is necessary to:

- Deposit a load to the ground.
- Lower and fully retract the boom moving the forks to about 1 m above the ground.
- Turn off the vehicle.
- Get off the vehicle and manually move the forks to the desired width.



## 9.6.7 - Fork extensions

**ATTENTION**

**Before starting to use the equipment, inspect and test it as described in the section "Forks Safe Working Procedures".**

Before starting to use the equipment, refer to the "Safety regulations" and "Safe Working Procedures" described in the manual of the vehicle on which the equipment is installed.

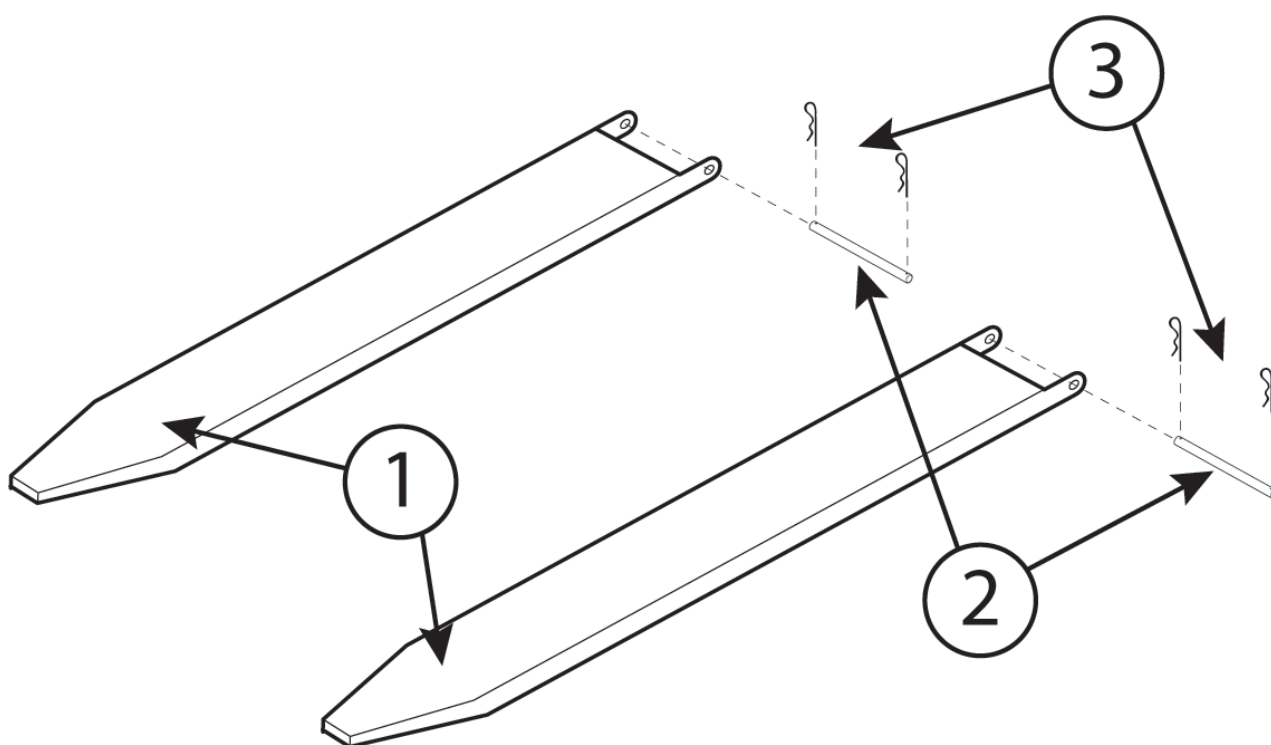

Figure: 150521-1

The fork extensions consists of the following main components (fig. 150521-1):

1. Extension
2. Fastener pin
3. Safety plug

### Warnings for use

- Use the extensions only with the forks for which they were constructed.
- Before use, check their integrity.
- Always apply the pin with the related cotter pin.
- Do not use loads exceeding those indicated by the forks on which the fork extensions are mounted.
- Refer to the load chart of the forks to which are applied the fork extensions.
- Make sure of the load stability.
- Do not take the load with a single extension.
- Do not use extensions for purposes other than those for which they were constructed.

### Installation

- Fit the extension on the forks after establishing the integrity of the extension and the forks.
- Put the fastener pin "2" with the related safety plug "3".



## **DANGER**

Never use if the forks or the extensions if they are defective or show tampering signs.

### Forks extension check

- At each use check the integrity of welds and repair if necessary.
- When the thickness of the lower metal sheet reaches 80% of its original thickness, the extension must be replaced.

**9.6.8 - Forks safe working procedures**

**9.6.8.1 - General instructions on forks use**



**DANGER**

**Never lift a load slung with a single fork or with a board.**

It is absolutely forbidden to use the forks with hooks, straps or other materials for handling suspended loads. Use the appropriate accessories (hook, winch, jib).

- Always set the forks fully under the load and move it to the transport position (forks at 300mm from the ground and tilted backwards, with fully retracted boom).
- The load diagrams are valid for centers of gravity indicated on the diagram. For a center of gravity at a greater distance, contact your dealer.
- Pay attention to the risk of crushing limbs when adjusting the forks manually.
- It is absolutely forbidden to increase the length or width of the forks with extensions not provided directly by the Manufacturer. In this case DIECI is raised from any responsibility regarding their use.
- Forks overloading and transverse stress are strictly prohibited.
- Place the forks to their maximum possible width depending on the load to be moved. Before lifting a load make sure that the width of the forks corresponds to that of the pallet or that these can withstand the weight of the load on the pallet. Forks set wide apart maintain a stable load.
- Place loads evenly on the forks, to obtain a stable balance. When lifting wide loads, or not centered and that are impossible to center, maneuver the vehicle with caution in order to prevent this from tipping. Use caution when lifting bars of considerable length.
- Do not raise the load with the tip of the forks facing downwards. The forks must always be with the tips pointing upwards; in this way the load will lean against the plate of the forks. A lifted load can be tilted forward only if it must be placed on a stack or directly on a discharge surface.
- Do not use the vehicle to transport or move persons when the forks are assembled on it. Use suitable interchangeable equipment approved by Dieci.

**9.6.8.2 - Load transport position with forks**

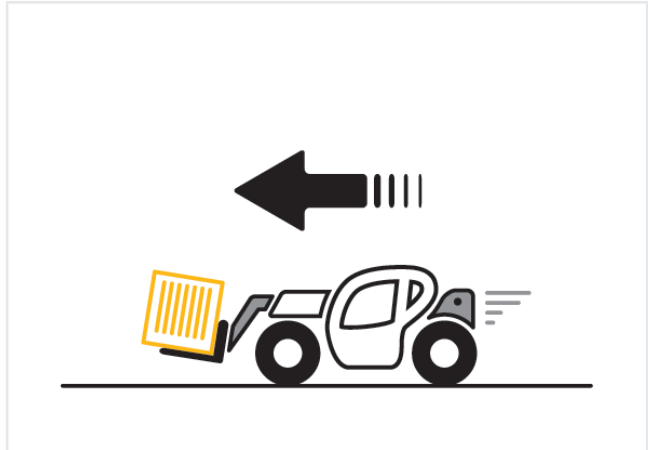

Figure: 150527-1

To correctly transport a load with forks it is necessary to:

1. Fully retract the boom.
2. Lower the boom fully down so that the forks are at about 300 mm from the ground.
3. Tilt the fork tips upward.

**9.6.8.3 - Picking up a load from the ground**

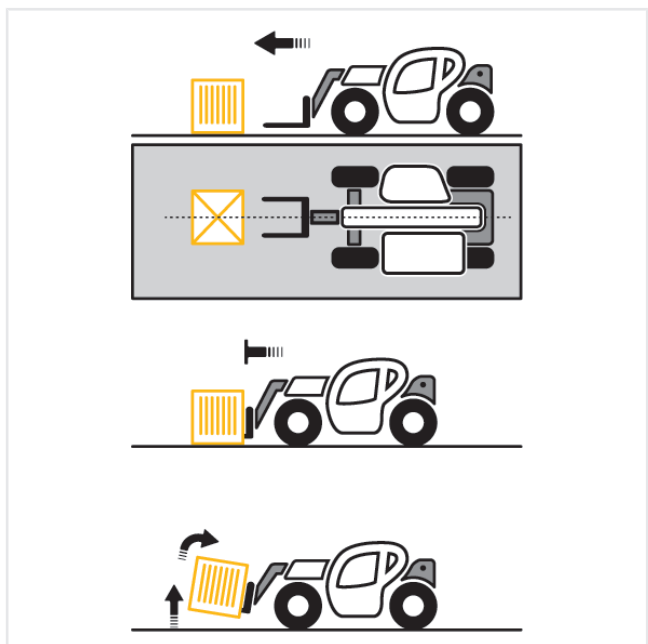

Figure: 150528-1

1. Slowly move the vehicle to the load to be lifted with the boom fully retracted and the forks in a horizontal position at the height of the lifting position. Keep the forks raised just enough to avoid contact with the ground.
2. Bring the forks under the load to be lifted up to the contact with the attachment holding plate.
3. Press the brake pedal and move the gear selector in neutral.

- Slightly lift the load and tilt the attachment holding plate backward setting it in the transport position.



### WARNING

Always observe the center of gravity of the load, tilt the forks enough to ensure stability and prevent the loss of the load during braking.



### DANGER

Never carry a load with boom raised and/or removed.

#### 9.6.8.4 - Picking up a load from a high position

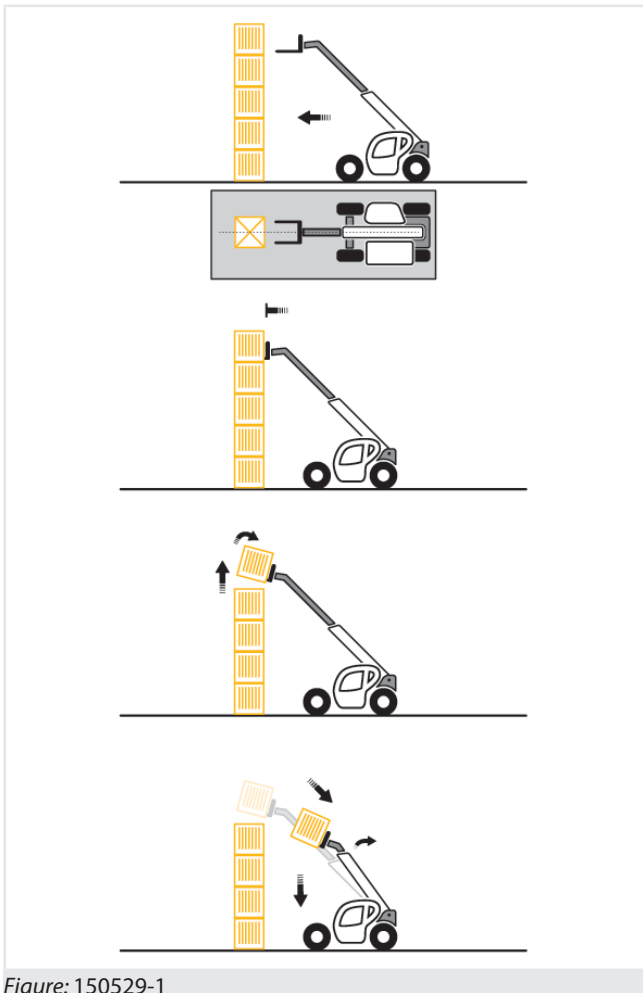

Figure: 150529-1

- Make sure that the forks pass easily under the load.
- Drive slowly and cautiously approaching the vehicle to the load placing it perpendicular to this with the forks horizontal. If necessary, use the inching pedal to approach slowly.

- Always remember to keep the distance required to insert the forks under the load, between the stack and the vehicle.
- Extend the boom for the shortest possible length.
- After bringing the forks under the load to be lifted until it is in contact with the fork holding plate, press the brake pedal and move the gear selector in neutral.
- Lift the load and tilt the fork holding plate to the transport position.
- If possible lower the load without moving the vehicle.
- Lift the boom to move the load away, then retract the extensions and lower the boom to set the load in the transport position.
- If not possible, move the vehicle backward very slowly and very carefully, after moving the load away properly retract the extensions and lower the boom to set the load in the transport position.



### WARNING

Always observe the center of gravity of the load, tilt the forks enough to ensure stability and prevent the loss of the load during braking.



### DANGER

#### Danger of tipping

It is absolutely forbidden to pick up a load if the vehicle is not level.

Never carry a load with boom raised and/or removed.

9.6.8.5 - Positioning a load in a high position

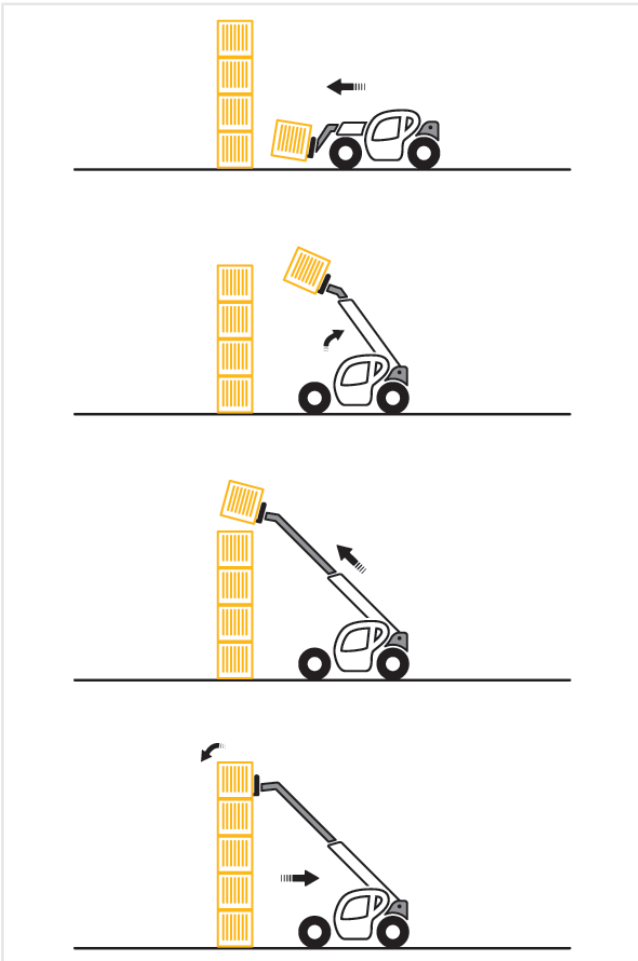

Figure: 150530-1

1. Bring the load in the transport position in front of the stack.
2. Lift and extend the boom to take the load above the stack. If necessary, move the vehicle towards the stack very slowly and very carefully. If necessary, use the inching pedal to approach slowly.
3. Press the brake pedal and move the gear selector in neutral.
4. Place the load horizontally and lay it on the stack, lower and retract the extensions to properly position the load.
5. Release the forks alternately retracting the extensions and lifting the boom; if possible make the vehicle move back very slowly and very carefully.



**WARNING**

Always observe the center of gravity of the load, tilt the forks enough to ensure stability and prevent the loss of the load during braking.



**DANGER**

**Danger of tipping**

It is absolutely forbidden to pick up a load if the vehicle is not level.

Never carry a load with boom raised and/or removed.

9.6.8.6 - Picking up a round load

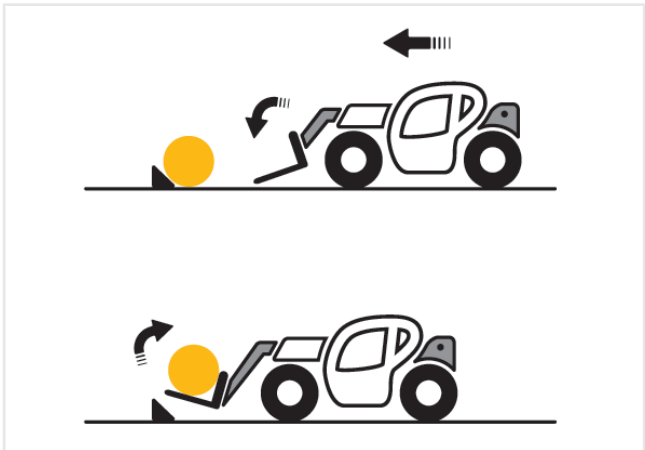

Figure: 150531-1

1. Tilt the forks forward and retract the telescopic boom, while inserting the forks under the load.
2. Rotate the fork carrier plate backward to slide the load. If necessary secure the load with wedges.



**WARNING**

Always observe the center of gravity of the load, tilt the forks enough to ensure stability and prevent the loss of the load during braking.



**DANGER**

Never carry a load with boom raised and/or removed.



**NOTE**

There are various interchangeable equipment such as grippers to facilitate the work with objects which are round, contact your DIECI dealer.

## 9.7 - Bucket

### 9.7.1 - Buckets identification

Buckets allow handling inert material.

To ensure a prompt and efficient service when ordering parts or when requesting information or technical clarification always specify the serial number.

Therefore we recommend to note the data relating to the accessory in your possession in order to safely and quickly identify them in the future, in case of need.

The data necessary for the identification of the buckets are positioned on the right side, in the upper part "A" (fig. 150522-1).

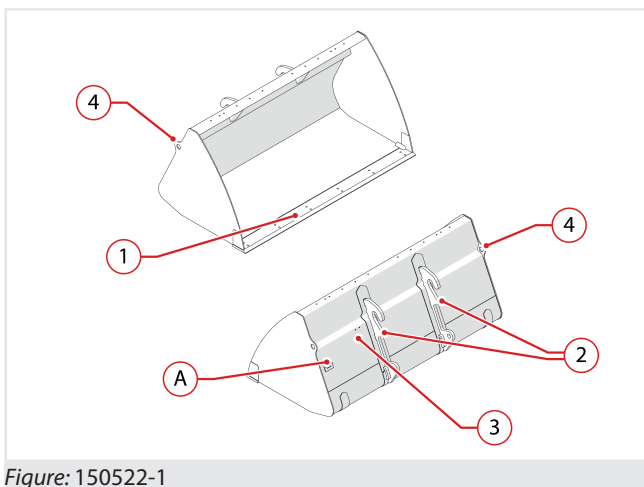

Figure: 150522-1

### 9.7.2 - Buckets description

All the buckets (fig. 150522-1) consist of the following components:

1. Blade
2. Hooks for plate connection
3. Tilt indicator
4. Hooks for lifting

### 9.7.3 - Buckets safety stickers

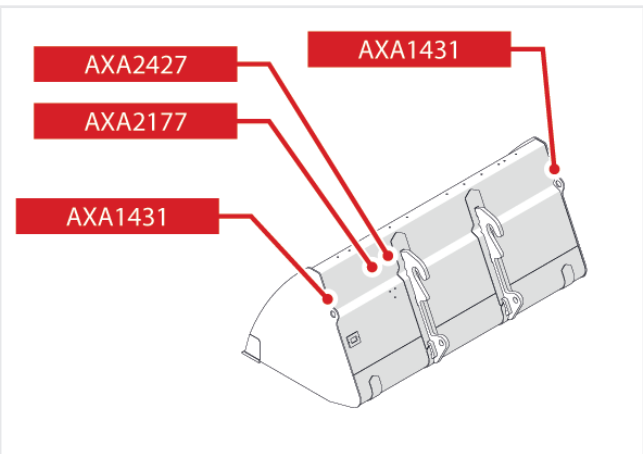

Figure: 150524-1

Safety stickers on buckets (fig. 150524-1):

- AXA2427 – Keep the safety distance from the equipment
- AXA2177 – Read the use and maintenance manual.
- AXA1431 – Lifting hook

### 9.7.4 - Bucket use



#### WARNING

**Before starting to use the equipment, inspect and test it as described in the section "Equipment pre-use check".**

It is absolutely forbidden to use the forks or any type of equipment, without securing it to the attachment holding plate with the appropriate safety plugs.



#### DANGER

Before each use, check the wear status of the equipment, they could be worn out and not hold the load to be handled creating a dangerous situation.

Before starting to use the equipment, refer to the chapters:

- a) "Safety regulations"
- b) "Buckets Safe Working Procedures [▶ 160]"
- c) "Equipment pre-use checks [▶ 131]"



**ATTENTION**

Set the appropriate working mode of the vehicle during the bucket use. If this is not done properly, the anti-tipping device could start up and the movements will consequently stop during the bucket excavation or the loading.

To use buckets with Pegasus model vehicles, it is necessary to select the equipment on the anti-tipping device (fig. 171070-1). For the load charts of the Pegasus vehicle when using the bucket, refer to the fork diagram. Extending the boom beyond the letter "A", the loads are halved with respect to those shown on the fork diagram.



171070-1

To use the buckets it is sufficient to move the plates tilting controls.

Moving the joystick to the left, the tip of the bucket will move up; moving the joystick to the right, the tip of the bucket will move down.

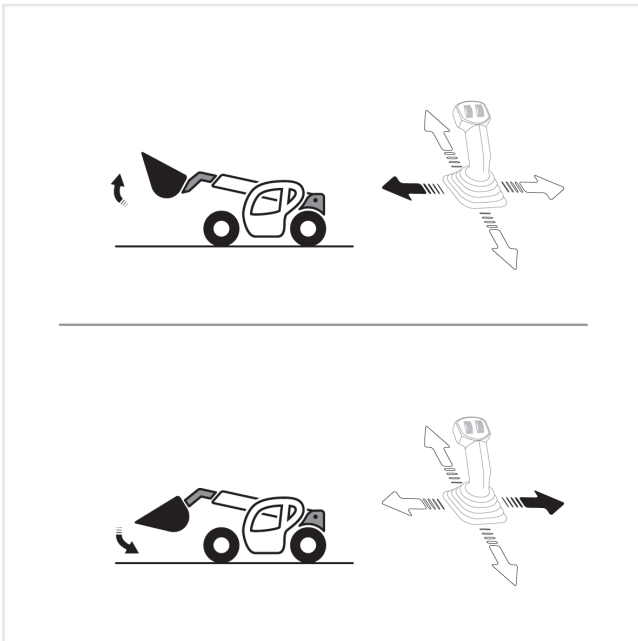

Figure: 150630-1



**WARNING**

Given the large size of the buckets, for some movements it will be necessary to remove the boom to prevent contact of the bucket with other parts of the vehicle. It is advisable to operate with the minimum possible extension of the boom.

**9.7.5 - Fixed tilt indicator use**

In the left part of the bucket there is the fixed tilt indicator (fig. 161030-1), this tool allows to know the angle of the bucket during use.

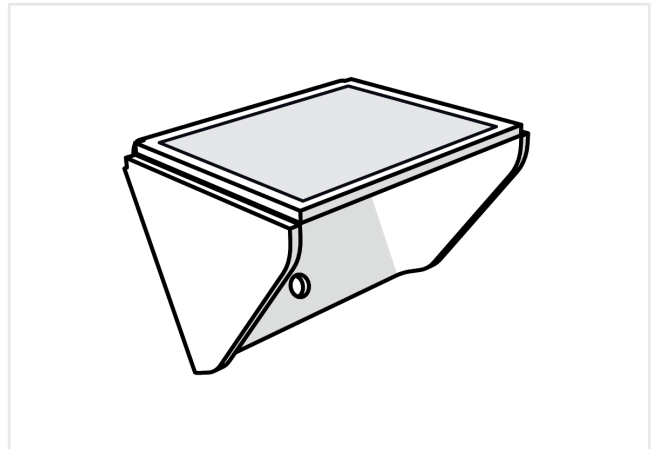

Figure: 161030-1

The bucket position can be determined based on the face shown by the fixed tilt indicator:

- **Upper visible face:** the bucket blade is turned upward
- **Face parallel to the ground:** the bucket is aligned to the ground
- **Lower visible face:** the bucket blade is turned downward

During the bucket loading phase, to obtain the maximum efficiency of the bucket it is appropriate to use the bucket aligned to the ground.

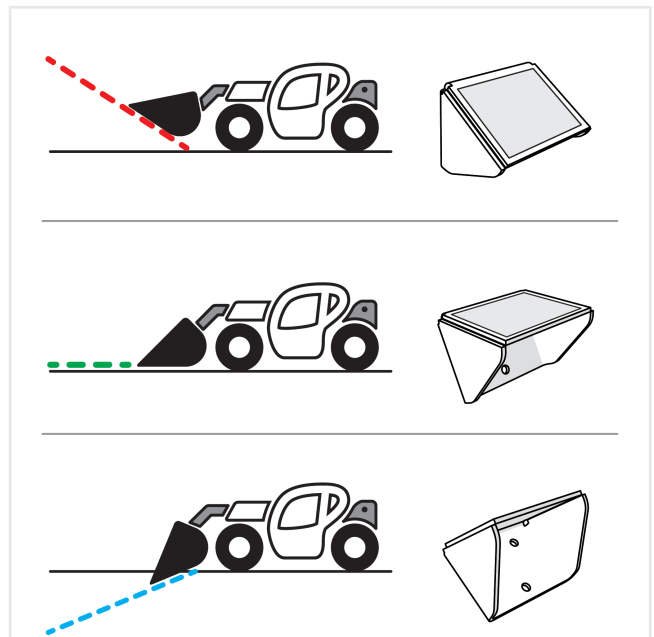

Figure: 161030-2

### 9.7.6 - Movable tilt indicator use \*



#### NOTE

The movable tilt indicator is an optional accessory.

In the left part of the bucket there is the movable tilt indicator (fig. 161031-1), this tool allows to know the angle of the bucket during use.

It is composed of a pendulum "1" and by two indicators "2".

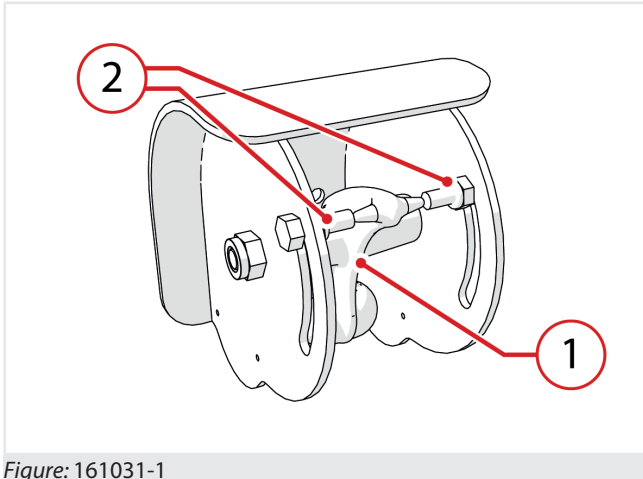

Figure: 161031-1

The bucket position is determined according to the position of the pendulum "1" compared to the indicators "2":

- **Pendulum above the indicators:** the bucket blade is turned upward
- **Pendulum at indicators level:** the bucket is aligned to the ground
- **Pendulum below the indicators:** the bucket blade is turned downward

During the bucket loading phase, to obtain the maximum efficiency of the bucket it is appropriate to use the bucket aligned to the ground.

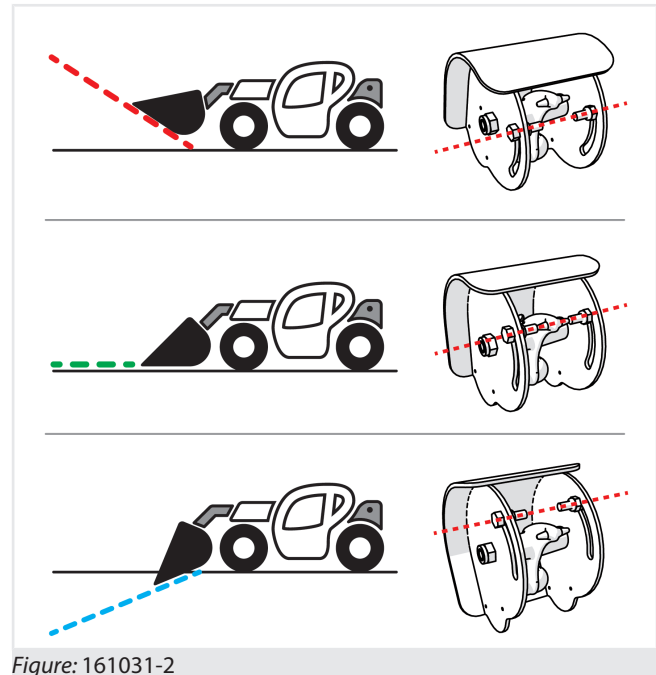

Figure: 161031-2

### 9.7.7 - Buckets Safe Working Procedures



#### DANGER

Do not change the structure of the equipment.



#### DANGER

Do not use the equipment for lifting persons, animals or things other than those specified.

#### 9.7.7.1 - Checks before lifting

Before starting the operations, perform these checks and inspections to ensure greater safety for operators.

- Positioning of the vehicle and ground conditions.
- Check the dimensions and characteristics of the work area and complete visibility of the load and of the surrounding area. Otherwise use a person on the ground assigned for signaling.

#### 9.7.7.2 - Danger zones

The danger zones of the vehicle can be identified in the work area of the vehicle and of the bucket.

This area varies in size depending on:

- Load characteristics and size
- Load lifting height



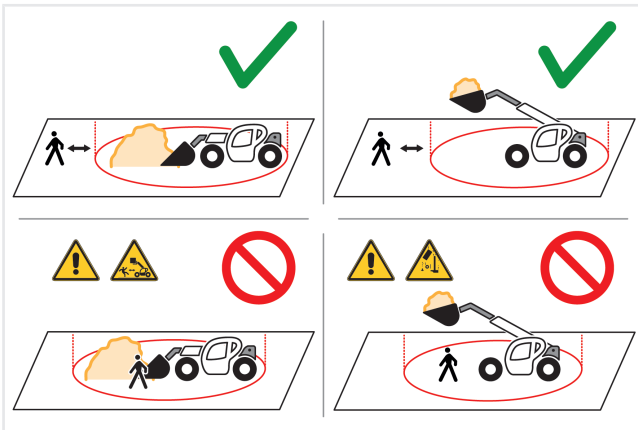

Figure: 150631-1



**DANGER**

Keep away from the vehicle during operation and from the aggregates to be moved, or from the excavation.

**9.7.7.3 - Bucket load**

It is strictly forbidden to push or stack inert material with extended boom. It can cause serious damage to the vehicle.

It is strictly forbidden to push or stack material using the boom extension. It can cause serious damage to the vehicle.

It is strictly forbidden to make leveling or digging operations in reverse. It can cause serious damage to the vehicle.

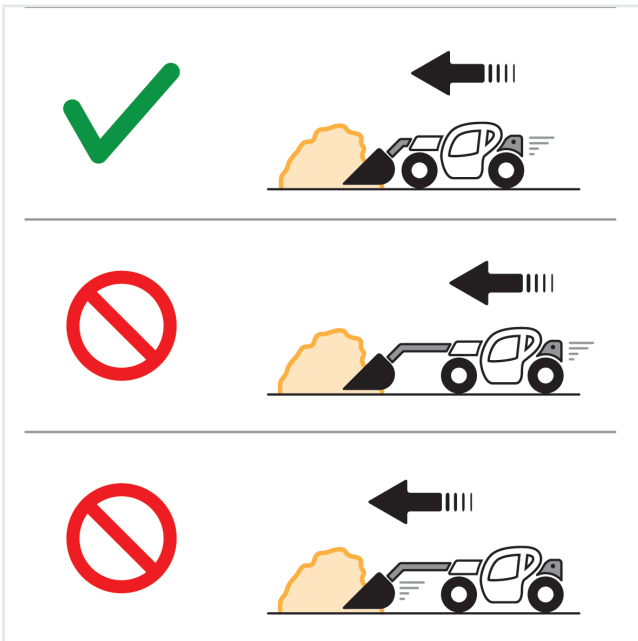

Figure: 150632-1

It is strictly forbidden to push or stack material with the vertical bucket planted in the ground.

**9.7.7.4 - Bucket unloading**



**WARNING**

It is strictly forbidden to repeatedly beat the swinging cylinder at closing limit switch to detach material attached to the bucket.

It can cause serious damage to the vehicle.



Figure: Vertical bucket use

**9.7.7.5 - Carry a load with bucket**

The correct vehicle movement position with the bucket equipment installed is:

- Bucket as close as possible to the ground
- Boom retracted as much as possible

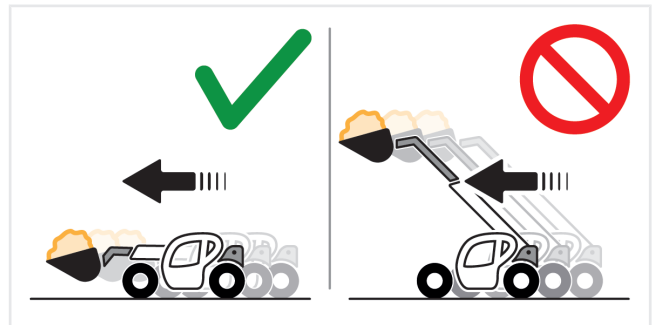

Figure: 150633-1



**WARNING**

It is advisable to keep the bucket at a height sufficient to be able to avoid roughness of the terrain along the way.

## 9.8 - Equipment lifting



### WARNING

**Make sure that the lifting device is adequate for the weight of the equipment to be lifted and that each device used for lifting and every accessory used is CE marked.**

Make sure that the ropes, chains, straps and hooks are in good condition and with capacity adequate to the weight of the equipment to be lifted.

The weight of the equipment is shown on a special riveted metal plate; check the overall dimensions for the maximum and minimum height values from the ground and the weight allowed.

Position the hooks into the holes for the lifting locates at the top, at the center of gravity of the equipment.



### DANGER

**It is absolutely forbidden to transport the vehicle with the equipment still installed on it.**



### DANGER

**It is absolutely forbidden to transport the vehicle with the equipment still installed on it.**

For details on the procedures to be followed during transport of the vehicle, refer to the Use and Maintenance Manual of the vehicle on which the equipment will be installed.

## 9.9 - Equipment transport



### WARNING

**Make sure that the capacity of the means of transport is adequate for the weight of the equipment to carry.**

When loading or unloading an equipment from a means of transport, there is always the danger of vehicle overturning.

Use a truck or a trailer suitable for transport of the equipment.

When transporting the equipment it is advised to use a support platform for easier handling.

Then fasten the equipment with appropriate slinging systems, check that they are in good condition and appropriate for the weight and dimensions of the equipment.

## 10.1 - Emergency procedure list

Emergency procedure	Additional information	
Emergency procedure	7.1.22	Warnings in case of vehicle tipping
	7.2.3	Deactivating the internal parking brake manually
	7.16.2.1	Manually disable off the 2-gear hydrostatic transmission
	10.2	Vehicle towing
	10.2.1	Vehicle towing with electrical panel on
	10.3	Man basket recovery in case of failure for Hercules
	10.3	Man basket recovery in case of failure for Hercules
	11.5.6	Start up with auxiliary batteries
	11.5.6.1	Cable connection and engine start-up
	11.5.6.2	Cables removal

## 10.2 - Vehicle towing



### DANGER

**The vehicle towing is a delicate operation and the risks to the operator are high. The manufacturer's warranty is not applicable in case of incidents or accidents that occur during towing. If possible make repairs where the vehicle is located.**

It is advisable that the towing operations are carried out by skilled personnel.

#### It is absolutely forbidden:

- Ever try to start the vehicle by pushing or towing.
- To tow the vehicle on public roads and for very long paths, if possible keep the yellow flashing light and the emergency lights in operation.
- To tow the vehicle on a slope.
- Stand between the towing vehicle and towed vehicle.



### WARNING

With the engine off the steering wheel and brakes servo controls do not work. If it is not possible to keep the engine running while towing the vehicle take into account that the efforts to use the steering wheel will be much higher than normal.



### ATTENTION

**The vehicle towing can be made only in emergency conditions at a maximum speed of 4 km/h (2.5 mph) and for short distances up to 500 m (1640 ft).**

To tow the vehicle over longer distances, contact *Dieci* service center.



### ATTENTION

It is mandatory to tow the vehicle with a rigid towing bracket. The towing bracket must be designed for a tensile stress of 10 tonnes (22040 lb). Attach the towing bracket between towing vehicle and the vehicle in failure at the points prearranged for towing.



### DANGER

Make sure that the weight of a towed vehicle not equipped with brakes never exceeds the weight of the vehicle that tows the vehicle. The distance required to stop the vehicle increases with the increase of the speed and of the load towed, in particular in the slope sections.

### 10.2.1 - Vehicle towing with electrical panel on

If it is necessary to tow the vehicle with the electrical panel in operation (for example, transmission failure) follow the following steps:

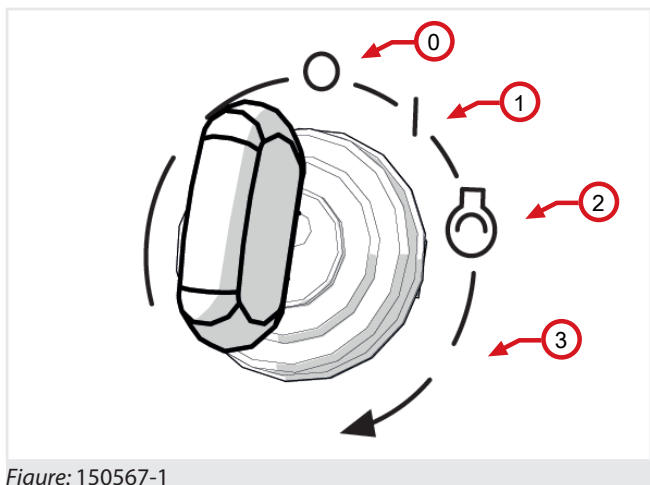

Figure: 150567-1

- Turn the vehicle off by turning the ignition key "0" (fig. 150567-1).

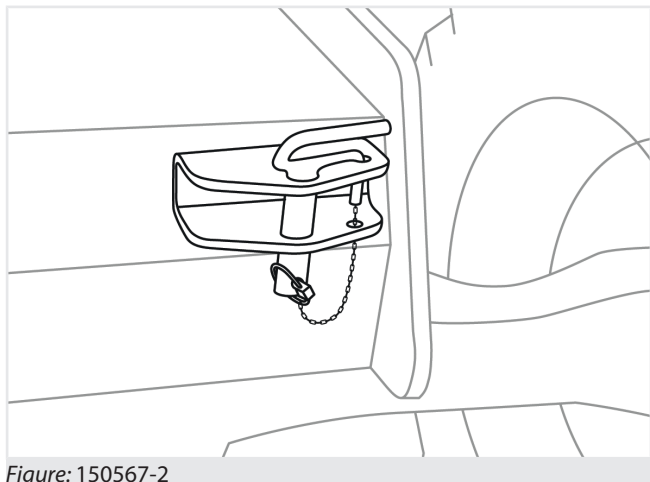

Figure: 150567-2

- Attach the towing bracket between towing vehicle and the vehicle in failure at the points prearranged for towing (fig. 150567-2).
- Make sure that the vehicle is in a stable configuration and lock the wheels with chocks to prevent accidental movement of the vehicle.
- Remove the lower protective casing by removing the screws with a wrench size **13**.

- Follow the steps described in the chapter "Manually disable the transmission".
- Switch on the electrical panel by turning the ignition key to position "1" (fig. 150567-1).
- Disengage the parking brake switch.
- Remove the wheels chock.
- During towing, remain seated in the driver's seat to prevent the parking brake from engaging automatically.

**10.2.2 - Towing the vehicle with engine in failure**

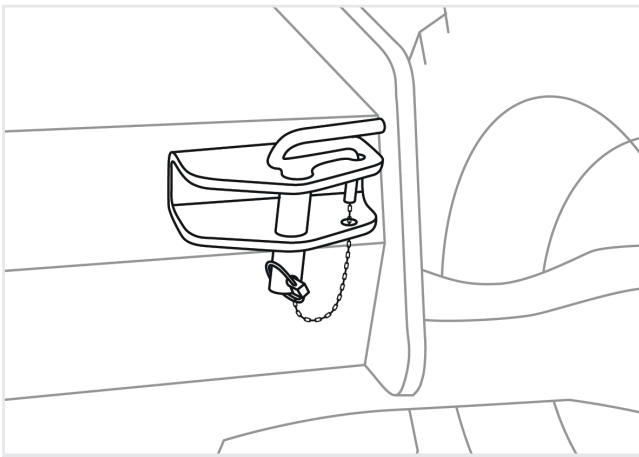

Figure: 150568-1

In case it is necessary to tow the vehicle with engine in failure, follow the following steps:

- Attach the towing bracket between towing vehicle and the vehicle in failure at the points prearranged for towing (fig. 150568-1).
- Make sure that the vehicle is in a stable configuration and lock the wheels with chocks to prevent accidental movement of the vehicle.
- Follow the steps in the section "Manually disable the parking brake on the vehicle front axle".
- Follow the steps described in the chapter "Manually disable the towing".



**DANGER**

**With the engine off, the drive and parking brake are still active.**

Towing the vehicle with active drive and brake can cause serious damage to the vehicle and create dangerous situations.

**10.3 - Man basket recovery in case of failure for Hercules**

In the case of lack of motive force during use of the vehicle with man basket, which leads to the man basket locking, it is possible to operate with the manual system to return the boom and the operators on the ground in safe conditions. In order to carry out this emergency operation use the appropriate emergency pump, located on the rear left side of the vehicle (150721-1).



**DANGER**

Under the emergency pump use conditions the anti-tipping systems are off. It is compulsory to refer to the load charts (found in the notebook in the cab and on the Use and Maintenance Manual) before performing any operation through the levers of the distributor. In this way it is possible, using the inclinometer and the letters on the boom, to know the exact location of the basket and of the work area within which it can operate. During the basket recovery there must not be no aggravating movements for the stability of the vehicle as there is a risk of tipping.



**WARNING**

Two qualified and experienced operators, authorized by the security officer, are required to complete the retraction operation.



**DANGER**

Do not ever try to get out of the man basket using makeshift equipment or using systems that expose to personal risk.

The operations that can be performed with the emergency pump are:

- Boom retraction
- Boom extension
- Boom lower
- Boom up

To carry out the manual boom retraction, perform the following procedure.

- Turn off the diesel engine.

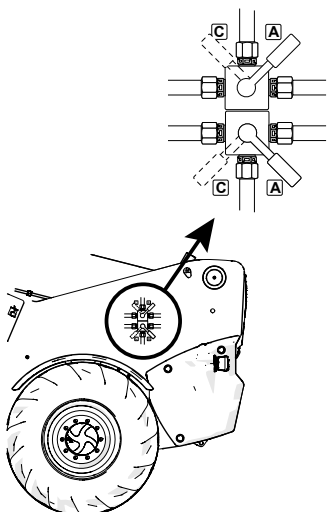

Figure: 150721-1

- Remove the safety clamp from the lever "1" (fig. 150721-2)
- Move the lever "2" (fig. 150721-2) from position **A** (open) to the position **C** (closed) (Fig. 150721-3). Only after this operation it will be possible to move the boom using the emergency pump.

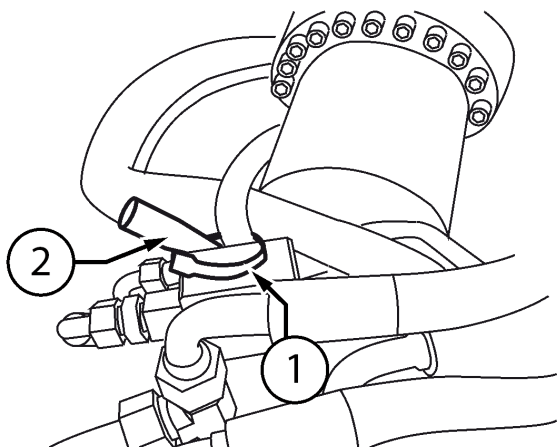

Figure: 150721-2

- **WARNING!** At the end of the basket recovery procedure, put the lever in position **A**.

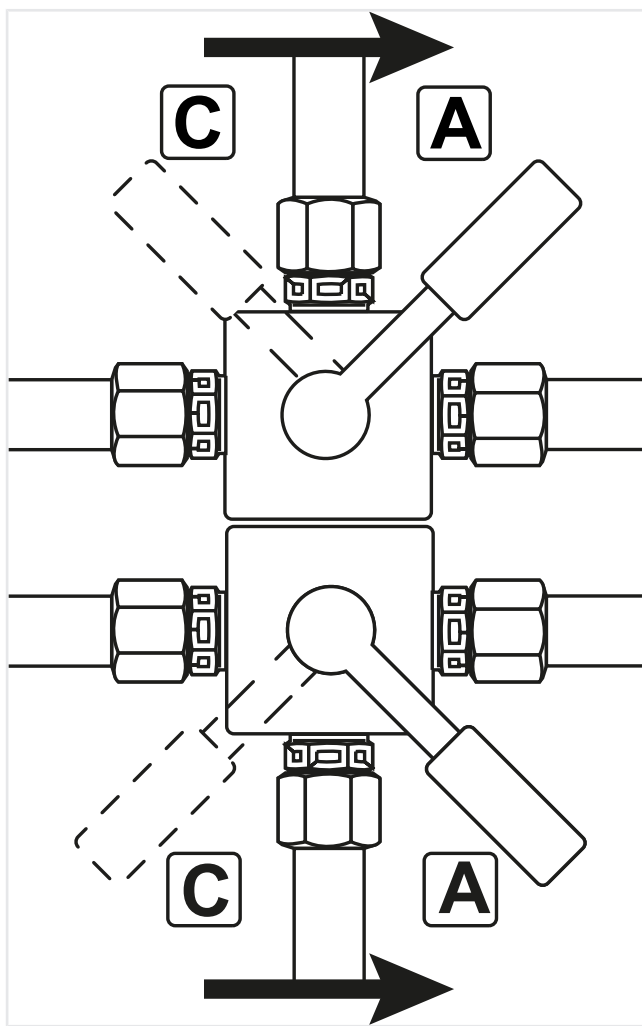

Figure: 150721-3



**WARNING**

The lever must only be operated for moving the boom downward.

Consequences



**WARNING**

Move the basket alternating movements of boom extension, retraction and lowering, always remaining within the load charts values.

- Place the hydraulic pipes according to the diagram shown below to make the desired movement

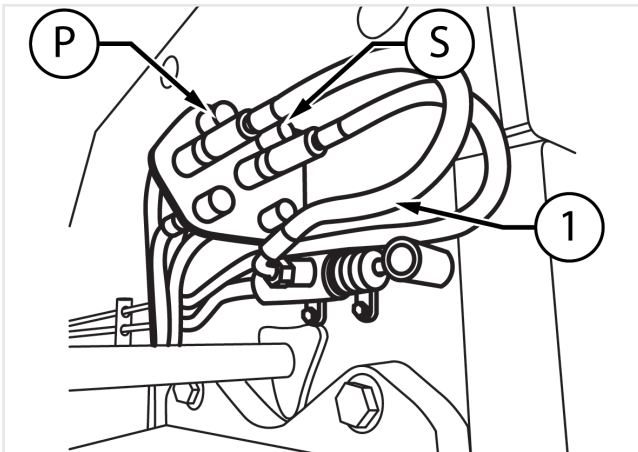

Figure: 150721-4

**NOTE!** Always clean the hydraulic contacts before making the hydraulic connections.

**A - Pipes position for boom up**

Place the hydraulic pipe which comes out from the pump (P) in position A1, and the other pipe (S) in position A2.

**A - Pipes position for boom lower**

Place the hydraulic pipe which comes out from the pump (P) in position A2, and the other pipe (S) in position A1.

**A - Pipes position for boom extension**

Place the hydraulic pipe which comes out from the pump (P) in position B1, and the other pipe (S) in position B2.

**A - Pipes position for boom retraction**

Place the hydraulic pipe which comes out from the pump (P) in position B2, and the other pipe (S) in position B1.

**E - Pipes position for normal working conditions**

Position both hydraulic pipes in position N.

- Pull out the rod placed in the toolbox and insert it into the housing of the emergency hand pump "1" (fig. 150721-4)
- Move the rod in both directions for operating the emergency pump.
- Move the boom so as to always stay within the working diagram.
- When the recovery is completed, put the rod into the toolbox.
- Return the distributor levers "1" (fig. 150721-4) to position A (fig. 150721-5) and secure them again with the clamps.

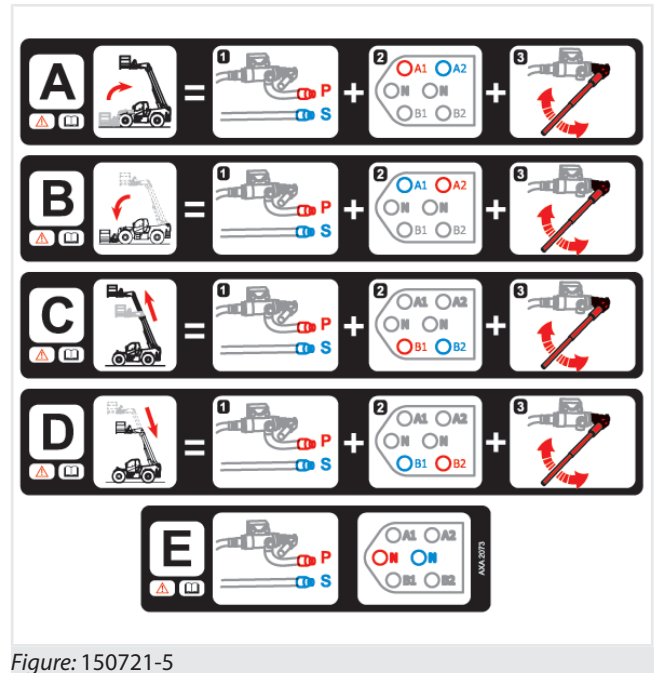

Figure: 150721-5



## WARNING

**Before performing any maintenance operations set the vehicle in the maintenance position.**

Use appropriate personal protective equipment during the various checking and maintenance operation of the vehicle.



## WARNING

**It is prohibited to carry out maintenance on the vehicle if this chapter has not been carefully read and learned.**

To learn about maintenance operations and time, refer to the Maintenance Log.

All maintenance operations must be recorded on the appropriate Maintenance Log.

## 11.1 - Maintenance warnings

This vehicle has been designed and built to provide maximum performance, savings and facilitate its operation in various working conditions. Before delivery, the vehicle and the equipment were tested both by the Manufacturer and by the Dealer to ensure their maximum condition. In order to preserve these conditions and to ensure trouble free operation, it is important to perform routine maintenance, as specified in this Manual at a **DIECI** dealer at the frequency required.

This section of the Manual provides all the maintenance prescriptions necessary for maintaining the **DIECI** vehicle in perfect working condition.

It is recommended that all services must be carried out as part of the assistance program recommended by **DIECI**. Remember that the owner and/or user is responsible of keeping the vehicle and equipment in safe operating condition and able to operate.

It should be noted, also, that proper maintenance of vehicle and equipment not only improves reliability, but preserves its value over time.



## ATTENTION

**Maintenance or repairs not covered in this chapter and in the rest of the manual should be performed only by **DIECI** Dealers.**

It is mandatory to have read and learned the "Safety" chapter before reading the "Maintenance" chapter.



## WARNING

When operating in corrosive environments it is important to intervene with appropriate maintenance methods and timing in order to prevent excessive wear of the vehicle.



## ATTENTION

Use appropriate personal protective equipment during the various checking and maintenance operations of the vehicle.



## WARNING

In case of malfunction do not use the vehicle until it has been repaired.

### 11.1.1 - Avoid accidents during maintenance

- Always clean and tidy the workplace in order to carry out every operation safely.
- Do not leave tools or other instruments scattered in a disorderly manner in the workplace.
- Clean grease traces, oil or other substances that could cause you to slip.
- For the workplace safety put rags soaked with grease and/or other flammable materials in a secure container.
- Use only tools appropriate for the task and make sure to use them in the right way. The use of damaged, poor quality, faulty, makeshift tools or not suitable for use may cause serious injury.
- Do not hit the vehicle and the equipment or their parts with a hammer or any other instrument, as projected fragments could cause injury.
- If inspection or maintenance is carried out on vehicles or equipment which are still covered with mud, oil, etc., operators risk sliding or falling



and the visual analysis of components is made more difficult. Thoroughly clean the vehicle or equipment before every operation.

- Make sure about the maintenance procedures before starting the work.
- Keep the work area clean and dry.
- Replace worn or faulty components.
- Eliminate accumulations of grease oil and debris.
- The knurled metal sheets (bulb plates) and the cab floor are the only parts of the vehicle that can be stepped on. Use a ladder (suitable for the intended purpose) for maintenance of parts that cannot be reached from the ground.



**DANGER**

**Do not carry out any maintenance operation with running engine or moving vehicle.**

Should maintenance need to be performed with the engine running, ask at least two workers for help and observe the following instructions:

- One worker must always be seated in the driver's seat, ready to switch off the engine at any time.
- All workers must remain in contact with one another.
- Take care not to remain entrapped in components during the execution of operations performed on the fan, fan belt or other rotating parts.
- Do not touch levers or control pedals. Should a lever or pedal need to be moved, always warn operators first so they can move out of the dangerous area.
- Do allow instruments or other objects to fall into the vehicle rotating parts, as these parts may break and be projected out.
- The vehicle must be outdoors when the engine is running. The vehicle can be kept in a closed area only if it is properly ventilated and the vehicle is equipped with specific purifiers.



**WARNING**

**In the case of operations to be performed by holding the boom raised, install the safety rod on the boom shaft.**

If you need to perform repair or maintenance work under the vehicle, firmly support the movable parts with blocks and supports that are solid enough to support the weight.

- Store attachments removed from the vehicle in a safe place where they do not risk falling. Take precautions to prevent unauthorized persons from approaching the storage area.



**DANGER**

Do not rest metal parts on the battery.



**DANGER**

**Danger of entanglement.**

Damage may be caused by entanglement in moving parts. To prevent accidents it is compulsory to wear proper safety equipment for maintenance.



**DANGER**

**Exhaust gas danger**

Exhaust engine gases are toxic and can damage your health.

The vehicle must be outdoors when the engine is running.

The vehicle can be kept in a closed area only if it is properly ventilated and the vehicle is equipped with specific purifiers.



**DANGER**

**Pressurized liquids danger**

After operation, the engine cooling liquid is hot and under pressure. Contact with hot water and/or steam may cause serious burns.

- Do not attempt to loosen connections, pipes or hydraulic components when circuits are under pressure.
- Avoid possible injury caused by hot water jets.
- Do not remove the radiator cap until the engine has cooled down.
- Before removing the cap, release all of the pressure.
- Prevent burns caused by oil or other hot parts during inspection or discharge by allowing the oil and cap to cool down before beginning operation.
- Even after the oil has cooled down, slightly loosen the cover or cap before removing it to mitigate pressure inside.



**DANGER**

**Burns danger**

Attention to burns. Engine reduction gear oil and the hydraulic system, pipes, engine and other components heat up when the vehicle is used. Wait until all parts cool down before beginning maintenance or repair work.

- Fluids such as fuel or hydraulic oil under pressure can penetrate the skin and eyes causing serious injuries. Take care to avoid these risks when repairing or doing maintenance work on the vehicle.
- Discharge the pressure (using the hydraulic levers of the distributors) before disconnecting or repairing pipes and hydraulic parts.



**DANGER**

When a hydraulic pipe needs to be disconnected, slowly loosen the fittings to discharge residual pressure.



**DANGER**

**Pressurized liquids danger.**

Hydraulic energy accumulators are mounted on the vehicle. Before intervening on them, make sure to discharge any internal pressure. Danger of high pressure oil splashes.

- Before restarting the engine, ensure that all fittings have been properly tightened.
- Use a piece of cardboard to check for any leaks; make sure your body is adequately protected against pressurized fluids.
- Any fluids that penetrate the skin must be removed surgically. Should there be an accident, seek medical attention immediately.



**DANGER**

**Corrosive substances danger**

Never touch air conditioning coolant.

- If it comes into contact with eyes, air conditioning coolant may cause blindness; it may cause freezing if it comes into contact with skin.
- When cleaning with compressed air, serious injury may be caused by flying particles.
- Always wear protective goggles, a dust mask, gloves and other protective equipment.



**WARNING**

**Adjusting and/or dismantling balancing and safety valves can be dangerous.**

One of the above-mentioned valves may be removed only when the concerned jack is at rest and the hydraulic circuit is not under pressure.

All other operations must be carried out by qualified, authorized personnel only.



**NOTE**

Only use lubricants suggested by DIECI; never utilize used lubricants.

11.1.2 - Personal protective equipment for maintenance



**WARNING**

Always use the personal protective equipment most suitable to the checking or maintenance operation to be performed.

Icon	Description
	Wear protective goggles <ul style="list-style-type: none"> <li>• Wear protective glasses in case of operations involving the use of compressed air.</li> </ul>
	Wear safety shoes
	Wear protective gloves <ul style="list-style-type: none"> <li>• Wear nitrile gloves in case of operations with grease, hydraulic oil or fuel.</li> </ul>
	Wear protective clothing
	Wear a protective mask



**DANGER**

**Danger of crushing**

Pay attention to moving parts to avoid danger of crushing or dragging of the lower and upper limbs. Avoid wearing jewellery or pendants that might be trapped in moving parts. Long hair must be tied back to avoid it being caught in moving parts.

Do not wear loose clothing, chains, belts or other accessories that may be caught in the control levers or in other parts of the vehicle.

**11.2 - Preliminary maintenance operations**

**11.2.1 - Prepare the vehicle in the "Maintenance position"**



**WARNING**

Before performing maintenance work on your vehicle, do the following:

- Park the vehicle on flat, even ground.
- Engage the parking brake.
- Lower and fully retract all mobile parts (booms, shovels, etc.).
- If the maintenance operation requires the mobile parts to remain up, apply the safety rod.
- Run the engine at a minimum for 60 seconds to cool it down.
- Release residual pressure from the hydraulic system.
- Switch off the key in the ignition switch.
- Remove the ignition key.
- Hang up a sign that indicates maintenance work is underway. This sign can be hung on the cab door and inside it on the controls.
- Set up barriers and spacers to prevent unauthorized personnel from approaching the vehicle.
- Disconnect the battery isolation switch.
- Allow the engine to cool down.

**11.3 - Engine hood opening**



**DANGER**

**Do not open the hood with the diesel engine in motion. At the end of the maintenance operations the hood must always be closed and locked.**

Do not work with the engine hood open.

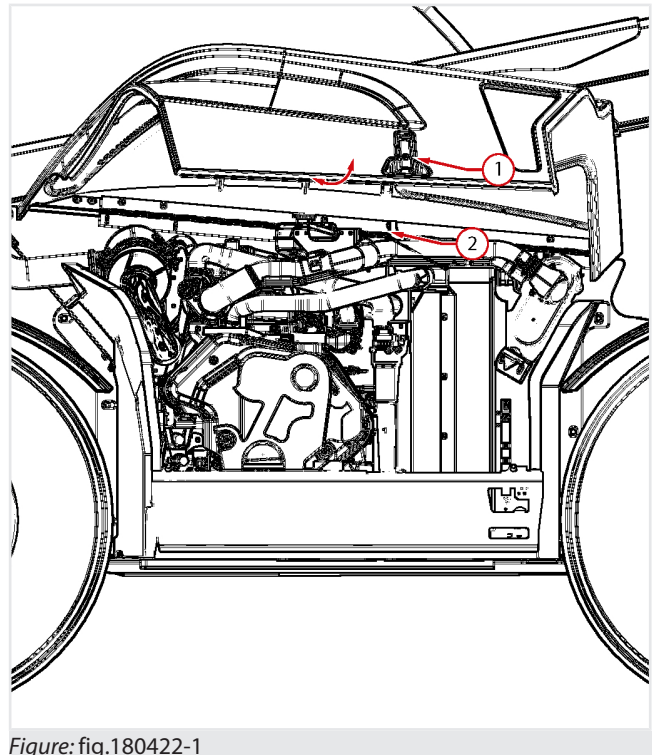

Figure: fig.180422-1

**To open the engine hood (fig. 180422-1):**

- Turn off the diesel engine.
- Remove the ignition key.
- Place in the cab a sign showing "Maintenance in progress".
- Disconnect the battery using the battery isolation switch.
- Lift the handle "1".
- Lift the hood up to the maximum extension of the support rod "2" in the open position
- Release the hood gradually to check that the rod is able to hold the hood.

**To close the engine hood it is necessary to:**

- Close the engine hood with light pressure.
- Keep the hood closed and lower the lever "1".
- Always check the proper closing before starting to work or before leaving the vehicle.

- Reactivate the battery isolation switch.

## 11.4 - Under chassis protection plate removal

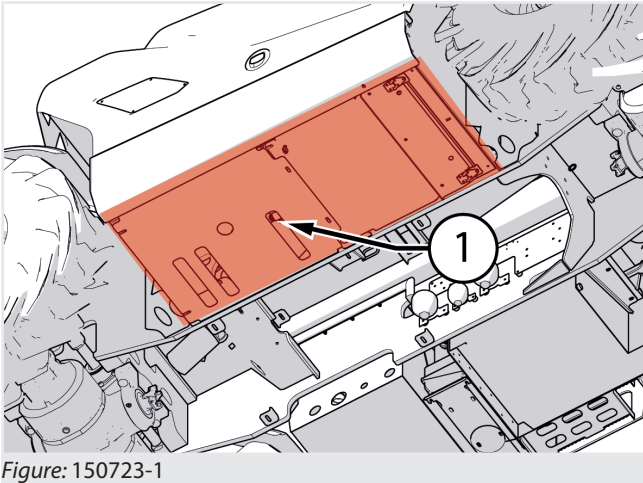

Figure: 150723-1

To perform maintenance operations it is necessary to temporarily remove the under chassis protection of the vehicle. The under chassis protection protects the bottom of the vehicle, from any bumps, collisions, dirt.

**To remove the under chassis protections (fig. 150723-1):**

- Place the vehicle in the maintenance position.
- Lock the wheels with chocks to prevent accidental movement of the vehicle.
- Unscrew the fastening bolts with a wrench size **13** and remove the engine under chassis protection "1".



### ATTENTION

At the end of the maintenance operations refit the under chassis protections.

## 11.5 - Battery



### DANGER

**To avoid the risk of explosion of the batteries:**

- Keep sparks, free flames and cigarettes away from the top of the batteries because the gases that they can produce are highly flammable.
- Do not charge damaged batteries.
- Do not charge a hot battery.



### DANGER



**Batteries contain highly polluting substances that must not be dispersed in the environment.**

Dead, old, damaged, batteries etc. must be properly disposed of.



### DANGER

**The battery contains sulfuric acid electrolyte which is a corrosive substance and must be treated with caution because it can cause poisoning and severe burns.**

Keep out of the reach of children.

Avoid contact with skin and eyes.



### ATTENTION

Wear protective clothing, gloves and safety glasses. In case of contact with eyes or skin, rinse immediately with plenty of water and seek medical attention. If swallowed, contact a doctor immediately.

- Do not overturn or tilt the battery as acid could come out.
- Charge the battery in a well ventilated area and always disconnect the power before removing the clamps.
- To check the charge status always use a voltmeter or a densimeter. If it is necessary to check the electrolyte level, use a flashlight, never a flame.
- Never place a metal object between the clamps to check the battery charge.
- Do not generate sparks with the cable clamps while charging the battery or starting the engine with an auxiliary battery.
- Check that the vent caps or covers are fitted correctly and firmly.
- Clean the top of the battery, check that the clamps are tight and cover them with a thin layer of petroleum jelly.
- In case of frozen battery this should be stored in a warm place to defrost. Do not use and do not recharge it: risk of explosion.
- In normal conditions the battery is kept charged by the alternator. If this becomes completely exhausted due to prolonged disuse or because at

the end of its life the alternator loses its capacity to "regenerate". The battery must be replaced and recharged using a special battery charger tool.



**WARNING**

Before performing any maintenance, disconnect the power supply to the electric circuit by pressing the battery isolation switch.

**11.5.1 - Low maintenance batteries**

The low-maintenance batteries have been studied to avoid maintenance interventions in ordinary and normal use of the battery. In case of discharge check the electrolyte level. For technical specifications contact the supplier or the manufacturer.

**11.5.2 - "Zero" maintenance batteries**

They are batteries that do not allow maintenance intervention.

When the battery is discharged it must be replaced. For technical specifications contact the supplier or the manufacturer.



**DANGER**

Do not carry out maintenance or recovery operations on "zero" maintenance batteries.

**11.5.3 - Battery: Instructions for recharging**

- A battery is fully charged if at constant temperature the density of the electrolyte and the measured voltage at the poles does not increase within 2 hours.
- Each recharge will be good as good are the general conditions of the battery. This means that an old battery, after charging, will not have the same life and efficiency of a new battery.
- The simplest charging method is to charge at constant power.
- At the end of the charging, the battery charger voltage increases and creates gasification. It is recommended to use simple battery chargers with minimum current control and timer.
- If the battery has a low electrolyte level restore it to the minimum level (just above the plates limit) then charge them. After the charging is completed, fill to the maximum level (to prevent leakage).

- Overcharging must be avoided because:
  - It is a loss of energy which causes the dissociation of water.
  - It produces loss of active mass for the electrodes deterioration
  - It creates a risk of explosion.
- If sulfated batteries are recharged without voltage limitation, they will boil and warm up with a risk of explosion.
- For old batteries (in most cases sulfated) charge with great caution. Even with 13.8 Volts there is the possibility of a temperature increase.

Follow these instructions to recharge the battery:

1. Disconnect the cables from the battery to protect the electrical system .
2. Place the battery at a safe distance.
3. If possible, remove the caps.
4. Check the electrolyte level, if possible.
5. Clean the poles.
6. Make sure the room is sufficiently ventilated.
7. Limit the charging current to a maximum of 1/10 of the battery capacity (Ah).
8. Connect the battery to the charger.
9. Connect the charger to the mains.
10. Turn on the battery charger.
11. The battery temperature must not exceed 55°C.
12. After finishing switch off the battery charger.
13. Disconnect the battery charger from the mains.
14. Disconnect the battery from the charger.
15. Check the electrolyte level, if possible.
16. Refit the caps.

**11.5.4 - Battery isolation switch**



**WARNING**

Use this switch only when the engine is stopped.

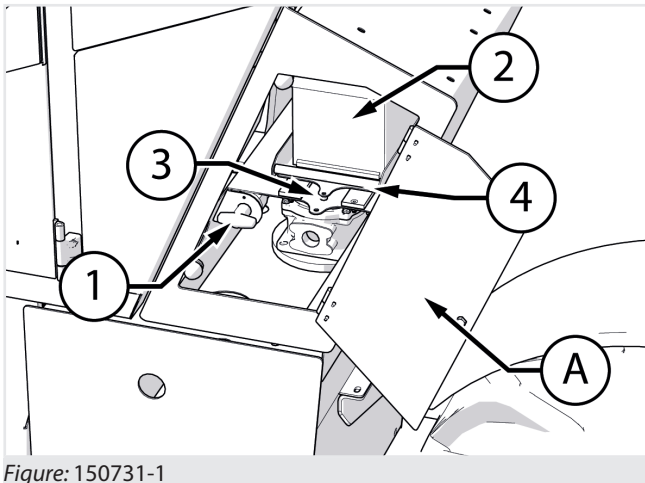

Figure: 150731-1

The battery cut-off switch "1" (150731-1) is located inside the compartment positioned behind the driver's cab, accessible opening the door "A". It allows the operator to isolate the battery from the electrical circuit in case of emergency or during maintenance operations.

To isolate the battery:

- Turn off the engine.
- Turn the ignition key to position "0".
- Turn the battery isolation switch counterclockwise to the off position.



## NOTE

If the vehicle is provided with the basket pre-arrangement it is also provided with a battery isolation switch with removable key, to ensure that it is not used accidentally.

## 11.5.5 - Battery: Replacement

The vehicle is equipped with a battery "2" (fig. 150731-1) located inside the compartment positioned behind the driver's cab "A".

Before removing the battery disconnect it from the electrical circuit through the appropriate battery isolation switch, following the instructions given in the relevant chapter.

To remove the battery:

- Place the vehicle in the service position as described in the "Setting the vehicle for maintenance" section.
- To access the battery use the ignition key to open the compartment "A".
- Unscrew the pin "3".
- Remove the battery by pulling the slide "4".
- Disconnect the NEGATIVE cable (black) from the battery.

- Disconnect the POSITIVE cable (red) from the battery.
- Remove the battery from the vehicle.
- Place the new battery.
- Connect the POSITIVE (red) cable to the battery.
- Connect the NEGATIVE (black) cable to the battery.
- Place the slide "4" in its initial position and fix with the pin "3".
- Reactivate the battery isolation switch.
- Close the engine hood.

## 11.5.6 - Start up with auxiliary batteries



### WARNING

**Start-up with auxiliary batteries is an operation that requires two properly trained and qualified operators.**

An error in executing the operations can cause serious damage to the vehicle, to property and people.

- When starting the engine using another vehicle, connect the accumulators in parallel. When connecting the cables, avoid contact between the positive cable "+" and the negative cable "-".
- Wear the necessary personal protective equipment before starting the operation.
- Take care to avoid contact between the vehicle to be started and the vehicle that must supply power to prevent sparks and explosions of hydrogen produced by the accumulators. The accumulator explosion causes serious damage and injury.
- Make sure not to exchange the ignition cables and first connect the earth cable (-) and then the positive cable (+).
- Be very careful when removing the ignition cables; to ensure that the cables disconnected from the accumulator do not touch other parts of the vehicle to avoid explosions caused by hydrogen.
- Cables and grippers must be proportional to the current load to be transferred. The accumulator to be used for the start-up must have a capacity greater than or at least equal to that of the standard accumulator installed.
- Check the cables and grippers for corrosion or damage. Make sure the grippers are tightly gripping the terminals.

- Be very careful during the different operations: direct or indirect contact with live parts can result in injury and sometimes even in death.
- When starting the engine, the operator must be in the driver's seat so as to keep the vehicle under control.
- All these operations must be carried out by skilled and trained personnel.

### 11.5.6.1 - Cable connection and engine start-up

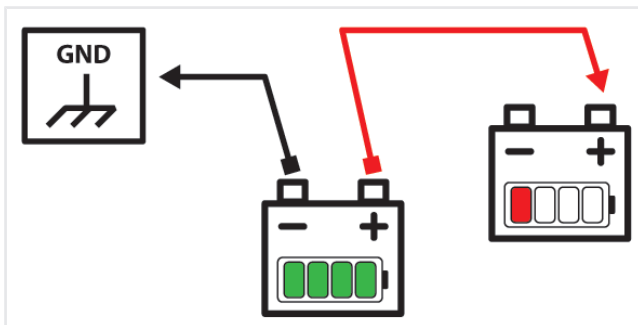

Figure: 150539-1

1. Make sure the ignition key is in position "O".
2. Connect the cable from the negative clamp "-" of the charged battery to the earth block of the vehicle to start-up.
3. Connect the positive terminals "+" of the two batteries to each other.
4. If a charged battery installed on a properly running vehicle is used, start the engine of the latter and run it at high rpm.
5. Start the engine of the failed vehicle.

### 11.5.6.2 - Cables removal

With the engine running remove the cables in reverse order of the connection.

1. Disconnect the positive cable "+" first from the battery used for starting and then from the low battery.
2. Disconnect the negative cable "-" from the earth of the running engine and therefore from the fully charged battery.

## 11.6 - Fuel



### DANGER



Never add different types of fuel such as petrol or alcohol to diesel.



It is forbidden to refuel while the engine is running.

It is forbidden to smoke when refueling.



### DANGER



Inhale diesel fumes for the least time possible as they are dangerous carcinogens for your health.

Before handling fuel and filling the tank, comply with the following regulations:

- Clean the area around the fuel cap. Refill the fuel tank at the end of every day to reduce condensation when the vehicle is at rest.
- Water and sediments must be removed before they reach the engine.
- Do not use antifreeze to remove water from diesel fuel.
- Do not rely on a filter to remove water from diesel fuel.
- Never leave the tank without a cap and always lock it. Should you lose the original cap, replace it with an original spare. Not just any cap is suitable.
- Keep the fuel pump gun under control while filling the tank.
- Do not inspect the tank with a flame.
- Do not fill up the tank completely. Leave room for expansion and immediately clean any spillage.
- In the event of fuel leaks due to breakage, stop the leak as quickly as possible, do not use the vehicle and contact DIECI customer service.

### 11.6.1 - Specifications for recommended fuel



### NOTE

To achieve good performance, see the engine manual of the vehicle to know the best features.

### 11.6.2 - Cleaning and storing fuel

It is important for the fuel to be kept clean.

The advice provided below will help maintain fuel quality.

- Never use zinc-coated containers.
- Never clean the inside of containers or power supply system components with cloths that may leave deposits.
- The cistern capacity must allow intervals between refueling not to be too long. A capacity of 3000 liters is sufficient for an average sized company.
- The storage cistern must be covered and placed on a support that is high enough to allow the vehicle refueling by means of gravity. A large basin for collection must be placed under the cistern in case of fuel leakage. The cistern must have an opening large enough to allow someone to access it for cleaning purposes.
- The delivery tap must be larger at the bottom in order to trap any deposits; it must also be equipped with a removable filter. The cistern should be tilted 40 mm per meter towards the sedimentation drain plug.
- The fuel barrels must be covered when stored to prevent water infiltration. The barrels should be slightly tilted slightly, so that any water will run to the upper rim. The fuel barrels should not be stored for too long before being used.
- If the barrels are kept outside, their caps must be tightly closed to prevent water from seeping in.
- After refueling the storage cisterns or barrels, it is recommended to allow the fuel to set for at least two hours, thereby allowing any sediment of water and impurities to be deposited before the fuel is used.

### 11.6.3 - Refueling

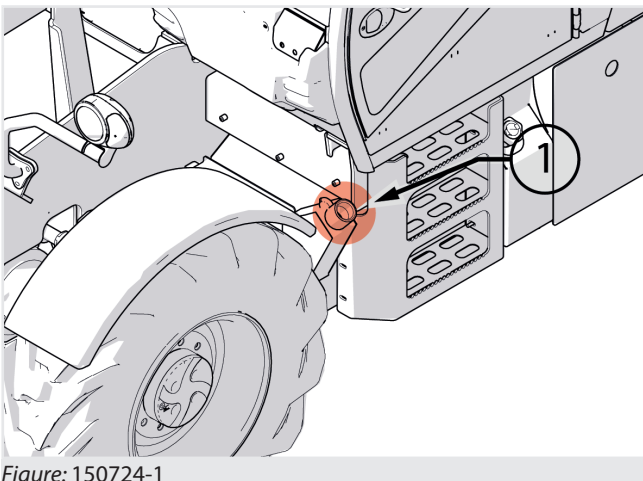

Figure: 150724-1

When refueling (fig. 150724-1) it is necessary to:

- Park the vehicle and turn off the engine
- Open the fuel cap
- Refuel
- Close the fuel cap

### 11.6.4 - Fuel tank: Cleaning

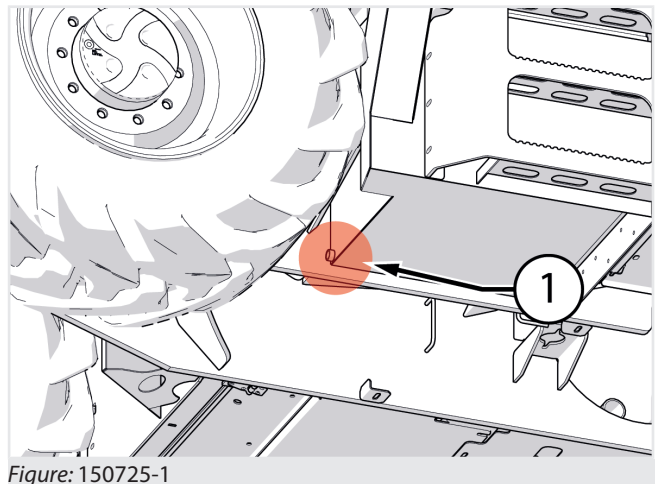

Figure: 150725-1

With the vehicle in the maintenance position:

- Place a suitable container under the fuel tank.
- Remove the plug from under the tank (fig. 150725-1) and drain the fuel to remove impurities present in the tank.
- Put back the cap and fill with clean fuel.

## 11.7 - AdBlue (Urea) system maintenance



### ATTENTION

Only qualified personnel can carry out maintenance operations on the AdBlue system.

Refer to the Dieci assistance service for more information.

### 11.7.1 - AdBlue filling

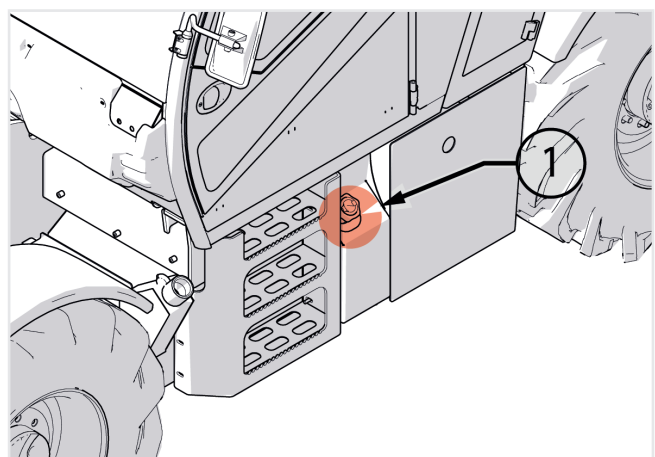

Figure: 150850-1

To top up the AdBlue level (fig. 150850-1) it is necessary to:

- Park the vehicle and turn off the engine.



- Open the AdBlue tank cap.
- Fill up.
- Close the AdBlue tank cap.

## 11.8 - Safety stickers: Inspection

- Check that all safety stickers are intact and in good condition.



### NOTE

Refer to the chapter "Safety Stickers Cleaning" for cleaning the safety stickers.

## 11.9 - Lubrication

Lubricate the points shown in the figure until grease comes out and clean the lubricators from dirt or deposits.

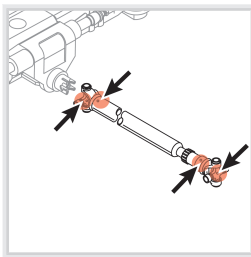

Drive shafts lubrication points.

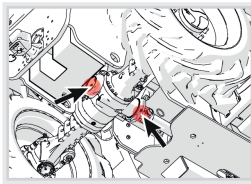

Swinging axle lubrication points.

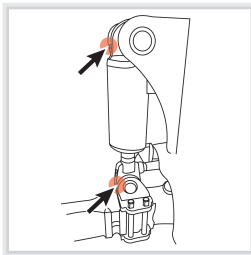

Leveling cylinder lubrication points.

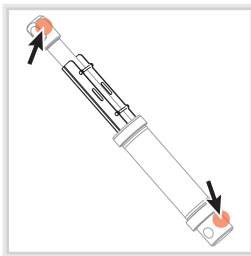

Lifting cylinder lubrication points.

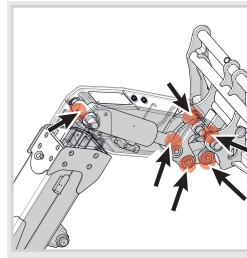

Counter lever and swing cylinder lubrication points.

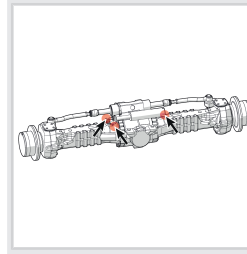

External parking brake cylinder lubrication points.

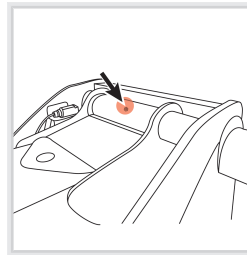

Boom-chassis pin lubrication points.

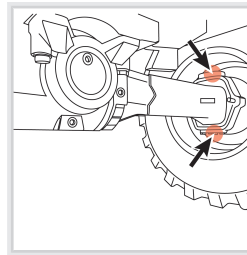

Wheels lubrication points.

## 11.10 - Engine maintenance



### NOTE

For the engine maintenance operations, refer to it manual.

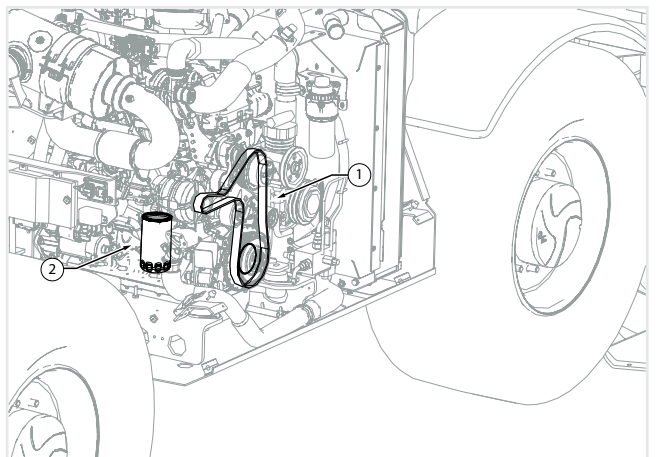

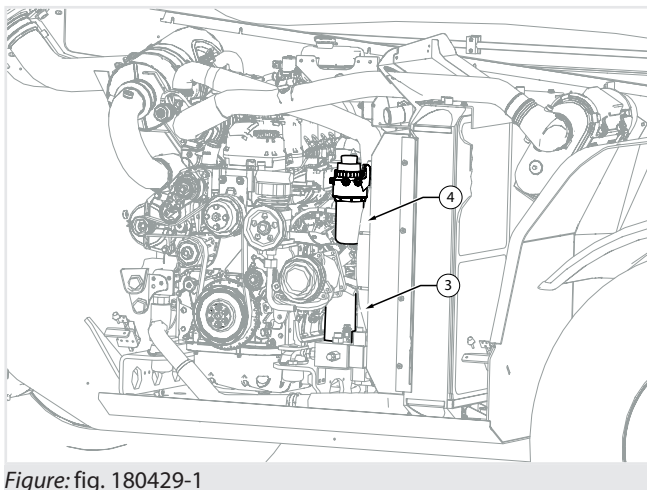

Figure: fig. 180429-1

### 11.10.1 - Belts: Check and adjustment

Check that the belt "1" (fig. 180429-1) does not have cuts, cracks or rubbing signs; when in doubt, install a new belt.

Make sure that the belt is properly fit on the pulleys and that the tensioner is working properly.

**NOTE!** If the belt does not appear in good condition, replace it with a new one.

### 11.10.2 - Fuel filter: Replacement

In the engine compartment there are the fuel pre-filter "4" (fig. 180429-1) and the fuel filter "3".

**NOTE!** Refer to the engine manual for the fuel filter replacement operations.

### 11.10.3 - Engine oil filter: Replacement

The engine oil filter "2" is present in the engine compartment (fig. 180429-1).

**NOTE!** Refer to the engine manual for the operations to replace the engine oil filter.

### 11.10.4 - Engine oil: Check and filling up

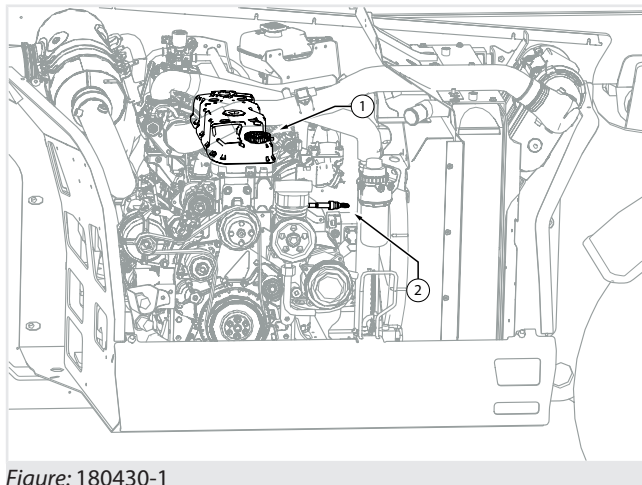

Figure: 180430-1

- Check the level with the vehicle on level ground and the engine turned off. Wait at least 5 minutes to allow the oil to settle into the sump.
- Pull out the dipstick "2" (fig. 180430-1), clean it and insert it back fully down.
- Pull out again the dipstick "2" and check that the oil level is between the "MIN" and "MAX" mark.
- Put back the dipstick and insert it fully down.
- If necessary, add oil from the cap on the engine "1".

For the amount and type of oil, refer to the engine manual.



#### WARNING

**Do not fill beyond the "MAX" mark; if the amount is excessive, oil burns with production of smoke and possible damage to the DPF.**

Never operate the engine with the oil level below the "MIN" mark.

### 11.11 - Air filter: Cartridges cleaning and replacement



#### ATTENTION

The inspection, cleaning and replacement must be carried out with the vehicle in the maintenance position.

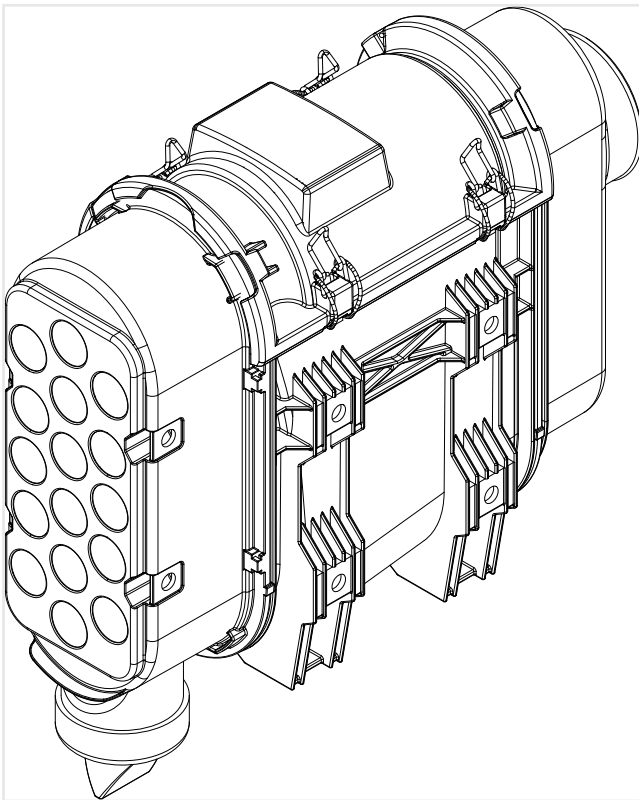

Figure: 150615-1

An air filter (fig. 150615-1) in bad conditions results in the reduction of power, excessive fuel consumption and reduced engine life.



150615-2

A clogged filter is signaled by the indicator light (fig.150615-2) located on the dashboard of the vehicle; after the clogging indication it is possible to continue operating for a period not longer than 10 hours. The maintenance must however be performed at the frequency required.



**WARNING**

When the clogging is indicated, it is possible to continue working for not more than one hour.

It is recommended to:

- Clean the filters only when the indicator light indicates clogging or at the frequency required. Unnecessary and too frequent cleaning exposes the elements to damage by handling that can allow dust and dirt to pass through the filtering stage and cause engine damage.
- In case the filter elements are in contact with liquids of any kind they must be replaced.

- Periodically check the intake sleeves, replace them immediately in case they are damaged or deteriorated.
- Periodically check the tightness of the bolts and clamps. Air must not be allowed to get into the engine circulation without having first gone through the filter.

For the complete efficiency of the filter it is recommended to operate with the filter complete with all its parts and components, assembled in the correct way.

Each deteriorated part must be replaced as soon as possible.



**ATTENTION**

**For the complete efficiency of the filter it is recommended to operate with the filter complete with all its parts and components.**

Each deteriorated part must be replaced as soon as possible.

It is absolutely forbidden to operate without the engine air filter.

The engine sucks air constantly during its use; dust particles entering in circulation may cause serious damage.

For proper cleaning of the filter it is necessary to:

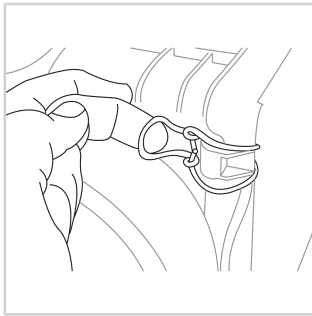

150615-3

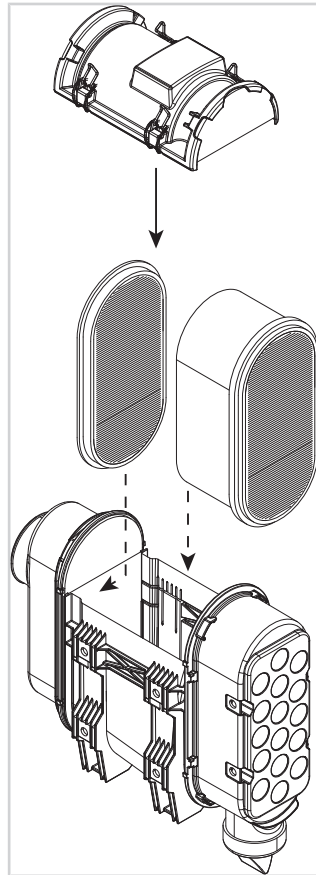

150615-4

- Prepare the vehicle in the maintenance position.
- Open and lock the hood.
- Open the filter cover (fig. 150615-3) pulling the locking levers located on the four corners.
- Lift the cover and remove the cartridges from inside the filter (fig. 150615-4).
- Use a wet lint-free cloth to clean the box and the cover.
- Clean or replace the filters. The filter cleaning is carried out with compressed air, up to **3 bar** (43.5 psi), at a distance of not less than **150 mm** (5.9 in), taking care not to damage the filtering element.
- Reassemble everything carrying out the same operations in reverse.

## 11.12 - Radiator maintenance

### 11.12.1 - Air recirculation grids and nets

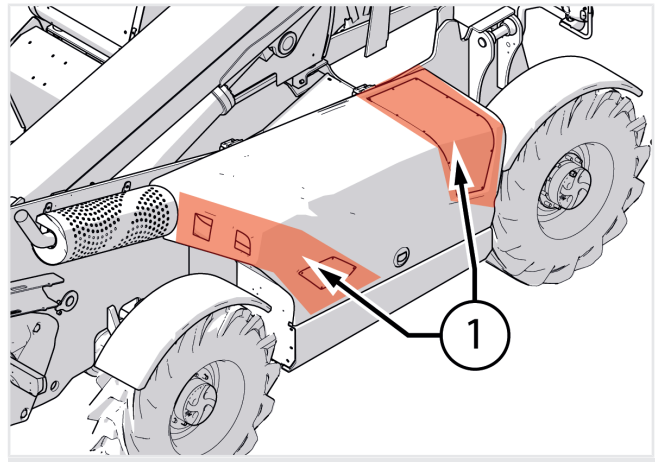

Figure: 150728-1

Check that the air recirculation networks and grids "1" (fig. 150728-1) are clean and free from dirt:

For cleaning use a jet of air at low pressure from the inside to the outside of the vehicle.

### 11.12.2 - Radiator: Checking and cleaning

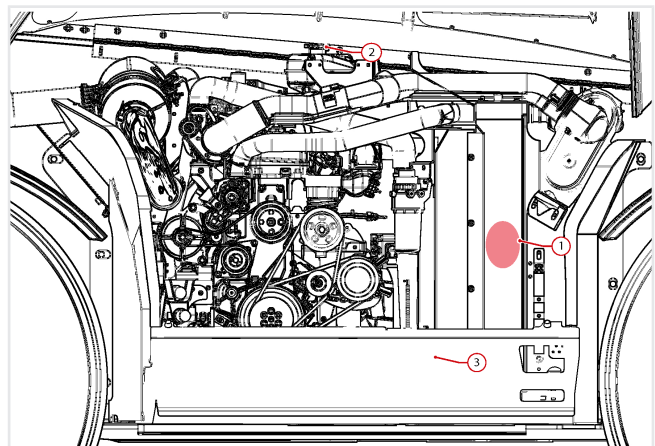

Figure: 180432-1

The oil and water radiator "1" (fig. 180432-1) involve the following steps:

#### Radiators check

- Check that the fins are not deformed; in that case straighten with caution.
- Check that the fins have not accumulated dirt and that they are not obstructed.

#### Radiators cleaning

- Prepare the vehicle in the maintenance position.

- Clean the radiator from dirt and impurities accumulated between the cooling fins. For cleaning use compressed air with pressure not exceeding 7 bar directed from the inside towards the outside.
- If necessary, apply a detergent solution and then remove it with a pressure washer.

### 11.12.3 - Radiator: Liquid filling up and replacement



#### DANGER

**Do not remove the filling cap of the radiator when the system is hot, otherwise it could cause leakage of boiling coolant. Once the system has cooled, turn the filling cap to the first mark and wait until the pressure has completely exhausted before proceeding.**

Risk of burns and injuries.



#### DANGER

**The coolant can be toxic. Avoid contact with skin, eyes or clothing. Rinse thoroughly with water in case of contact with skin and eyes. Consult a doctor immediately.**

If not reused, dispose of in accordance with local environmental regulations.

#### Filling up

- Prepare the vehicle in the maintenance position.
- Open the engine hood.
- Slowly unscrew the filling cap "2" (fig. 180432-1) counterclockwise until it reaches the safety switch cover.
- Exhaust the residual pressure and steam.
- Add the coolant up to the level of 30 mm (1.2 in) below the cap.
- Put back the cap.
- Close the engine hood.

#### Coolant replacement

- Prepare the vehicle in the maintenance position.
- Open the engine hood.
- Remove the discharge sleeve "3" (fig. 180432-1) to drain water from the radiator.

- Remove the filling cap "1" to speed draining.
- Allow the cooling system to completely drain.
- Rinse the radiator with clean demineralized water introducing it from the filling cap "1" and making it flow out from the orifice of the sleeve "2". If necessary, add detergent.
- Check the condition of sleeves and their fittings, replace them if necessary.
- Once cleaning has been completed, refit the drain sleeve "2".
- Fill the cooling system from the filler cap "1" until the level is 30 mm (1.2 in) below the cap with the coolant previously prepared.
- Close the filler cap.
- Close the engine hood.
- Start the engine at idle speed for a few minutes.
- Make sure there are no leaks, check the level and add more liquid if necessary.

### 11.13 - Hydraulic system maintenance

#### 11.13.1 - Hydraulic oil: Check and replacement

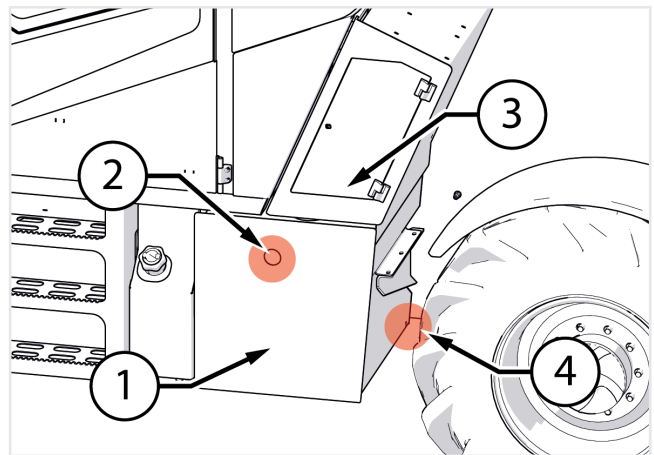

Figure: 150946-1

The hydraulic oil tank is located on the left side of the vehicle under the cab "1" (fig. 150946-1).

The level can be checked through the transparent cap placed on the left side of the vehicle "2".

The level is correct when the oil is visible from the transparent cap "2" with all the cylinders of the vehicle in the transport position.



## NOTE

See the chapter "Technical data" to know the amount and type of recommended oil.

### Oil check

To keep the vehicle in normal operation conditions, it is necessary to keep the oil level in best conditions.

To properly check the oil level in the tank it is necessary (fig. 150946-2):

- Prepare the vehicle in the maintenance position.
- Make sure that all cylinders and jacks of the vehicle are retracted (e.g. telescopic boom fully retracted and lowered, attachment holding plate tilted down as much as possible to avoid contact with chassis or tires). In this way all the oil of the hydraulic circuit will be sent in the tank.
- Check the oil level through the transparent cap "2". Under the best conditions, the oil level reaches the middle of the transparent indicator.
- If necessary, remove the cap of the tank "3" located inside the compartment behind the cab, and add oil until it reaches the proper level.
- Put back the filler cap "3".

### Oil change

To change oil in the tank (fig. 150946-3) it is necessary to:

- Prepare the vehicle in the maintenance position.
- Make sure that all cylinders and jacks of the vehicle are retracted (e.g. telescopic boom fully retracted and lowered, attachment holding plate tilted down as much as possible to avoid contact with chassis or tires). In this way all the oil of the hydraulic circuit will be sent in the tank.
- Place a container under the drain plug (located under the tank) "4".
- Remove the filler cap "3".
- Remove the drain plug to let the oil drain "4".
- After draining the oil, put back the drain plug "4".
- Fill the tank with the oil indicated
- Check the level through the indicator "2" after starting the engine and operated all hydraulic controls to remove air bubbles, if any.
- Close the filling cap "3".
- If necessary, top up the level

## 11.13.2 - Hydraulic oil intake filter: Replacement

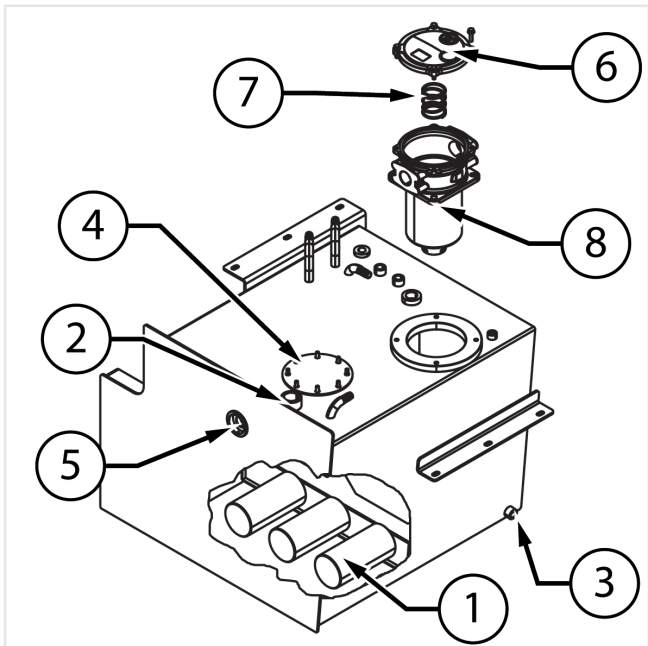

Figure: 150946-1

The internal hydraulic oil intake filters "1" (fig. 150946-5) are located inside the hydraulic oil tank; to replace them, completely empty the tank. It is therefore advisable to carry out the replacement of the intake filters in conjunction with the oil change.

To replace the intake filter, carry out the following operations (fig. 150946-5):

- Prepare the vehicle in the maintenance position.
- Make sure that all cylinders and jacks of the vehicle are retracted (e.g. telescopic boom fully retracted and lowered, attachment holding plate tilted down as much as possible to avoid contact with chassis or tires). In this way all the oil of the hydraulic circuit will be sent in the tank.
- Place a container under the drain plug (located under the tank).
- Remove the filler cap "2".
- Remove the drain plug to let the oil drain "3".
- After completely draining the oil, remove the flange "4" to access to the intake filters.
- Unscrew the intake filters "1" located inside the tank with an adjustable spanner.
- Install new filters and tighten with a wrench.
- Put back the drain plug "3".
- Fill the tank with the oil indicated.
- Check the level through the indicator "5" after starting the engine and operated all hydraulic controls to remove air bubbles, if any.
- If necessary, top up the level.

**11.13.3 - Hydraulic oil return filter**

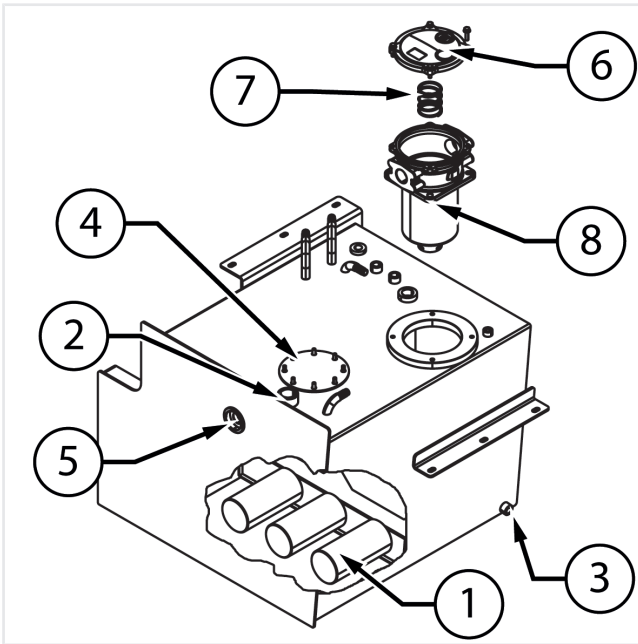

Figure: 150946-8

To replace the hydraulic oil return filter (fig. 150946-8) carry out the following operations:

- Prepare the vehicle in the maintenance position.
- Access the compartment located behind the vehicle driver.
- Remove the cover "6" unscrewing the 4 screws. Be very careful as the internal spring "7" pushes the cover outward.
- Remove the inner cartridge of the filter "8" and replace it with a new one.
- Remove the spring "7" from the empty cartridge and insert it into the new one.
- Insert the new cartridge in its housing, the spring must be located in the top of the cartridge.
- Close the cover being careful to correctly position the spring. Tighten and check that there are no leaks.

**11.13.4 - Hydraulic oil filter**

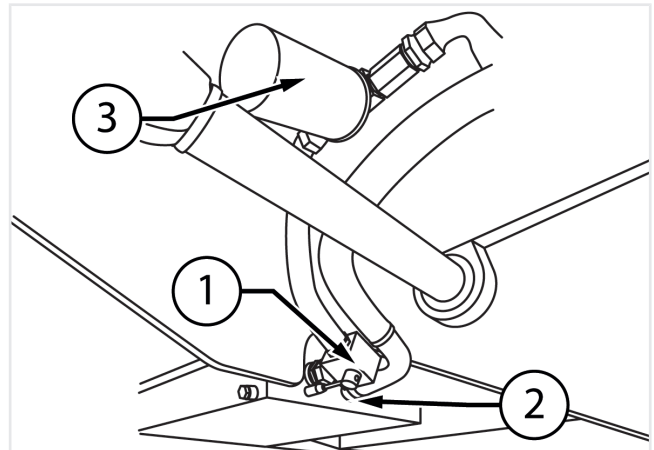

Figure: 151016-1

To replace the hydraulic oil return filter (fig. 151016-1) carry out the following operations:

- Prepare the vehicle in the maintenance position.
- Place a container under the filters in order to collect the oil coming out during replacement.
- Remove the lock screw "1".
- Close the valve "2" to avoid emptying the tank.
- Unscrew the filter cartridge "3" one at a time with a strap wrench.
- Clean the filter supports with a clean lint-free cloth. Check that the old sealing rings are removed.
- Take the new filters and fill them with hydraulic oil of the approved type. Use the same oil to lubricate the new sealing gaskets.
- Screw the filters only with the help of hands paying attention to the correct positioning of the previously lubricated sealing gaskets.
- Return the valve "2" in its original position.
- Secure the valve with the screw "1" previously removed.
- Start the vehicle and check for leaks.

## 11.14 - 2 speed transmission maintenance

### 11.14.1 - Oil change: Inspection

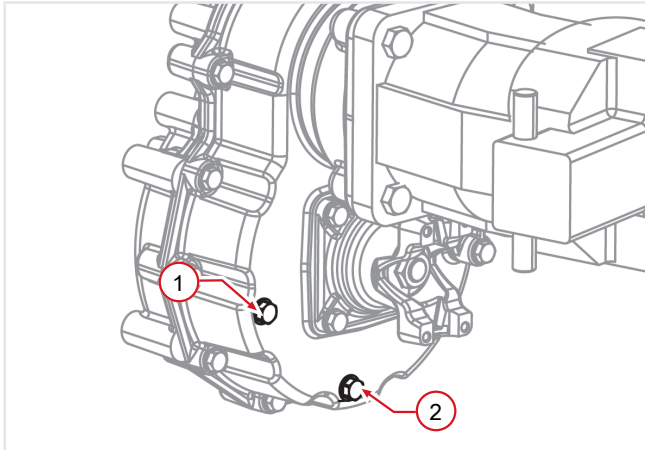

Figure: 150619-1

- Set the vehicle in the maintenance position.
- Place a container under the gearbox.
- Take the level cap off "1" (fig. 150619-1), oil must leak out from the hole.
- If necessary, top-up through the hole of the cap until the oil seeps through

### 11.14.2 - Oil change: Check and replacement

- Set the vehicle in the maintenance position.
- Place a container under the gearbox.
- Remove the level cap "1" (fig. 150619-1) and the drain plug "2".
- Allow the oil to completely drain out.
- Refit the drain plug and tighten it securely.
- Top-up with approved type of oil from cap "1" until the oil seeps through.

## 11.15 - Brakes maintenance

### 11.15.1 - Brake: Inspection

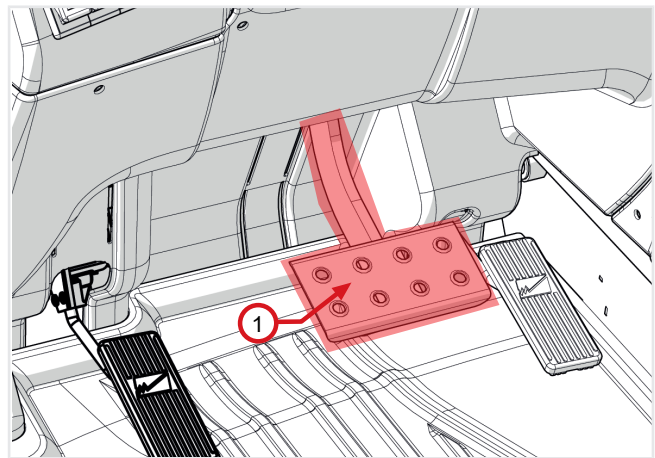

Figure: 161050-1

Visually check that the joints of the pedals (fig. 161050-1) are not damaged and that the pedal stroke is not excessive or too elastic.



### DANGER

**If irregularities in braking are noticed, contact qualified personnel to verify the cause of the trouble.**

The braking parts also safeguard the operator's safety, do not intervene personally on the braking system trying to eliminate possible anomalies.

### 11.15.2 - Brake: Coolant level check

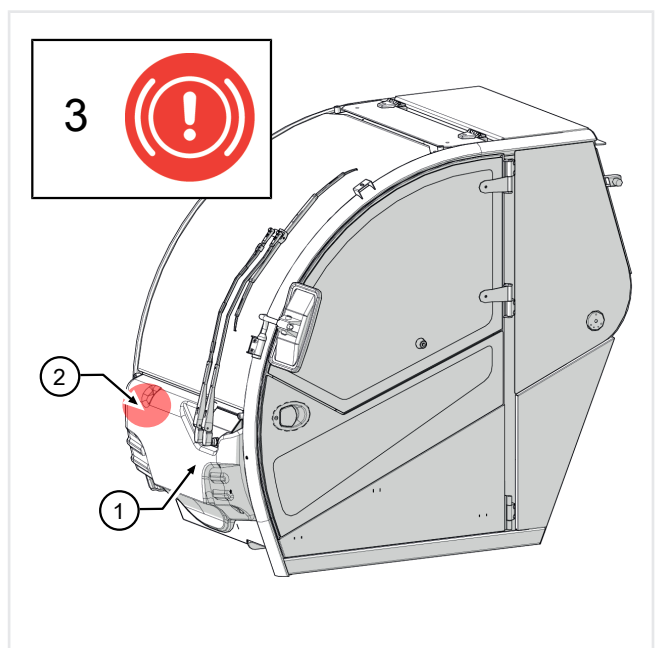

Figure: 150709-1



When the indicator light "3" (Brake fluid level low) flashes on the central instrument, it means that the brake fluid level has dropped below the minimum (MIN) and therefore it must be restored.

To access the tank, remove the front protection housing of the cab "1" (fig. 150709-1) and check that the oil level is always above the minimum level (MIN) indicated on the tank "2". If necessary top up from the cap.

**WARNING! If the light "3" stays on even after adding oil, contact a Dieci authorized service center to solve the problem.**

A slight lowering of the level is due to normal wear of the brake discs.

Do not press the brake pedal until the topping up is completed. Make sure the tank is closed before acting on the pedal.



**DANGER**

**The significant lowering of the level is an indication of leakage in the system. Refer to qualified personnel for the replacement of any damaged, corroded or ruined pipe.**

It is absolutely forbidden to operate with brake oil level below the minimum "MIN". The brakes may operate erratically with the risk of accidents.



**ATTENTION**

Always use oil of the prescribed grade, as indicated in "Technical data" chapter.

This type of oil can damage painted surfaces and plastic parts of the instrument panel. For safety precautions, refer to the "Safety regulations" chapter.

**11.16 - Wheel maintenance**

**11.16.1 - Epicycloidal reduction gear oil: Check and replacement**

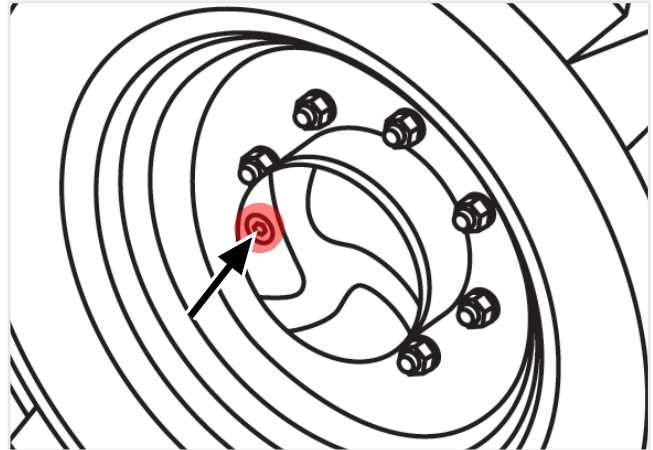

Figure: 150577-1

The oil cap of the epicycloidal reduction gear is located on the wheel hub (fig. 150577-1):

**When checking the oil level it is necessary to:**

- Prepare the vehicle in the maintenance position.
- Turn the wheel for the oil cap to be in the horizontal position (9 o'clock).
- Place a container to collect the oil.
- Remove the cap and verify that the oil seeps from the hole.
- If necessary, top-up through the same hole.
- Close the cap and tighten it securely.

**When replacing the oil it is necessary to:**

- Prepare the vehicle in the maintenance position.
- Turn the wheel for the oil cap to be in the lowest possible position (6 o'clock).
- Place a container to collect the oil.
- Remove the cap and let the oil drain completely.
- Turn the wheel and bring the cap to the horizontal position (9 o'clock).
- Fill through the same cap with new oil until it seeps through.
- Close the cap and tighten it securely.

**11.16.2 - Wheel nuts tightening**



**NOTE**

Tighten the nuts at the intervals required in the maintenance table.

Use the corresponding table to know the correct tightening torque.

Always tighten the nuts in opposing position, not consecutively.

After installing the wheel, tighten the nuts between the wheel and the axles. Then check the nut torque every day until the torque is stabilized.

The number of axle columns must match the number of nuts tightened. Then all the nuts on each wheel must be installed otherwise the vehicle can not operate.

In case of wheel replacement the vehicle or the raised side can be placed on the ground only with wheels installed and properly tightened.

The nuts tightening must be made first with the vehicle, or part of it, raised from the ground then with vehicle resting on the ground.

Only use **DIECI** original nuts for tightening the wheels. If you lose even one nut contact the **DIECI** service center.

### 11.16.2.1 - Wheel nuts tightening: Inspection

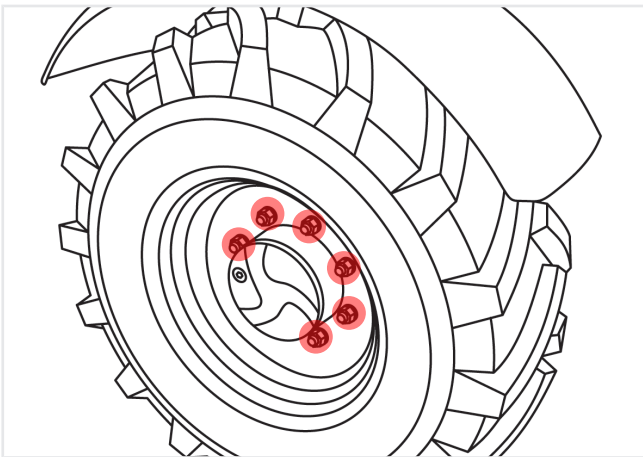

Figure: 150578-1

Check that the nuts of the front and rear wheels are tightened well, using a torque wrench (with a torque multiplier, if necessary).

Tapered nut	Torque
M18x1.5	460 N·m (339,02 ft·lbs)
M22x1.5	740 N·m (545,38 ft·lbs)

### 11.16.3 - Tires



#### ATTENTION

The diagrams notebook in the cab and in the "Technical data" chapter show the tires available for your vehicle model and the relative inflation pressures.



#### ATTENTION

On receiving the vehicle check the air pressure of the tires.

- Check the tire pressure regularly. The pressure must be checked with cold tires.
- The tire pressure must always be at the levels indicated.
- Check the size of the tires installed and the canvass amount for the correct inflation pressure.



#### DANGER

Tires showing cuts or excessive wear must be replaced immediately.

- At each use, check that the tire shoulders are not damaged.
- Keep oil, grease and corrosive liquids away from the tires to avoid deterioration of the rubber.
- To obtain the maximum efficiency do not use tires with more than 80% of tread wear.



#### WARNING

**Inflating or operating on the tires can be dangerous.**

To operate on tires or install them, contact specialized personnel.

In any case, to prevent serious or fatal injuries, follow the safety precautions below.

- The vehicle wheels are very heavy. Handle with care and make sure that, once stored, they can not fall and injure someone.
- Never try to repair a tire on a public road or highway.
- Make sure the jack is placed on a solid and flat surface.
- Make sure the jack is adequate for lifting the vehicle.
- Use ratchet jacks or other locking means suitable to support the vehicle during the tires repair.

- Do not place any part of the body under the vehicle.
- Do not start the engine while the vehicle is on the jack.
- Never hit a tire or a rim with a hammer.
- Make sure the rim is clean, without rust and undamaged. Do not weld, solder, repair in any way or use a damaged rim.
- Do not inflate a tire unless the rim is mounted on the vehicle or secured in such a way that it cannot move in case the tire or rim should break suddenly.
- Do not inflate any tire over the pressure indicated by **DIECI**. If the bead chafer does not settle on the rim, when arriving to this pressure deflate the tire and lubricate again with a solution of soap and water, inflate again. Do not use oil or grease. An inflation greater than permitted with bead chafer not settled may break the bead or rim with explosive force sufficient to cause serious injury.
- After installing the wheel, tighten the nuts between the wheel and the axles. Then check the nut torque every day until the torque is stabilized.



**ATTENTION**

**When fitting a new or repaired tire, use a valve adapter of spring type with distant pressure gauge that allows the operator to stay well away from the tire during inflation.**

Use a safety cage.

11.16.3.1 - Tire pressure: Inspection

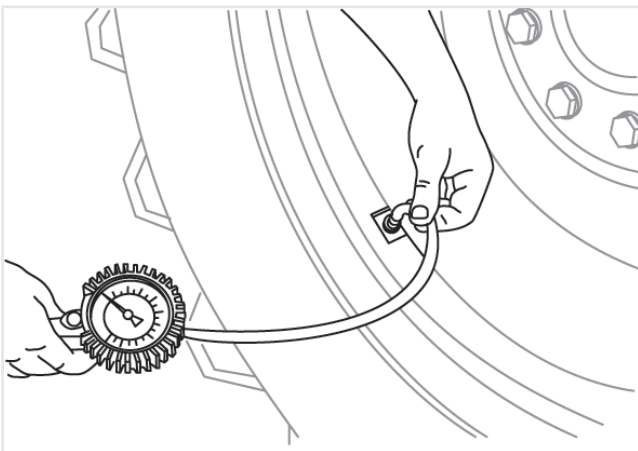

Figure: 150578-1

Verify and adjust the pressure of the front and rear tires.

Check that the tread and the sides are not damaged.

Connect a pressure gauge to the tire valve and verify that the inflation pressure is correct.

11.16.3.2 - Tires filled with urethane



**NOTE**

**Tires filling with urethane is an optional accessory.**

Consult your dealer in case of doubts or information on your vehicle.



**DANGER**

**It is not permitted to fit tires inflated with polyurethane foam unless authorized by the manufacturer.**

With tires filled with urethane it is forbidden to travel on the road.



**ATTENTION**

The maximum permitted speed with tires filled with urethane is 20 km/h (12.4 mph).

11.16.3.3 - Pneumatic symbols key

Icon	Description
	<b>Tire dimension</b> Indicate the tire pressure.
	<b>Tread pattern</b> Indicates the design with which the tire tread is carved.
	<b>Load index and Speed index</b> The load index corresponds to the maximum load that the tire can support. The speed index indicates the maximum speed at which the tire can bear the weight corresponding to its load index.
	<b>Tire pressure</b> For most vehicle models, tire pressure is the same for all wheels.
	<b>Front axle tire pressure</b> For some vehicle models, the tires must be inflated with different pressures between the front axle and the rear axle.
	<b>Rear axle tire pressure</b> For some vehicle models, the tires must be inflated with different pressures between the front axle and the rear axle.

## 11.17 - Lighting

The vehicle lighting must always be efficient and fully functional. Its operation must be checked every day. In case of damage to the lighting system immediately replace the damaged part. Immediately replace a burned out bulb.



### ATTENTION

Refer to the "Maintenance" chapter before making any adjustments or maintenance.



### NOTE

The bulbs are very fragile. Handle with care.

The low beam bulbs must not be handled with bare hands.

### 11.17.1 - Headlight

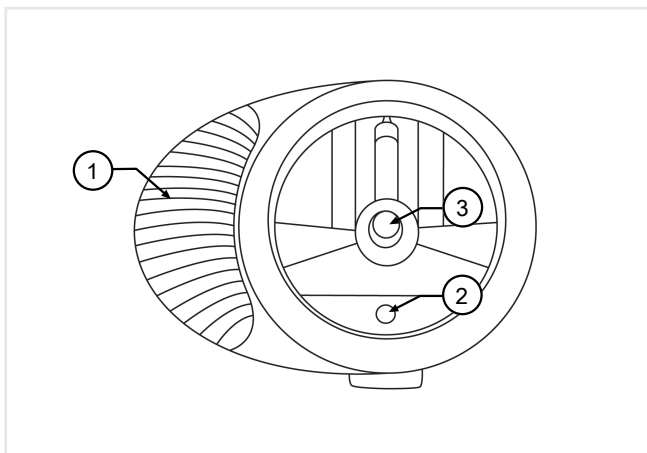

Figure: 150301-1

- |   |   |
|---|---|
| 1 | Direction indicator - 21 W                |
| 2 | Front side light- 4 W                     |
| 3 | Low beam and high beam light - 60/55 W H4 |

#### To access the bulbs:

- Prepare the vehicle in the maintenance position.
- Turn off the battery isolation switch to disconnect power to the electrical system.
- Remove the power supply connector on the back of the light.
- Remove the front of the headlight by loosening the screws placed in the rear cap.

To close the headlight operate in the reverse order, paying attention to correct positioning of the sealing gasket.

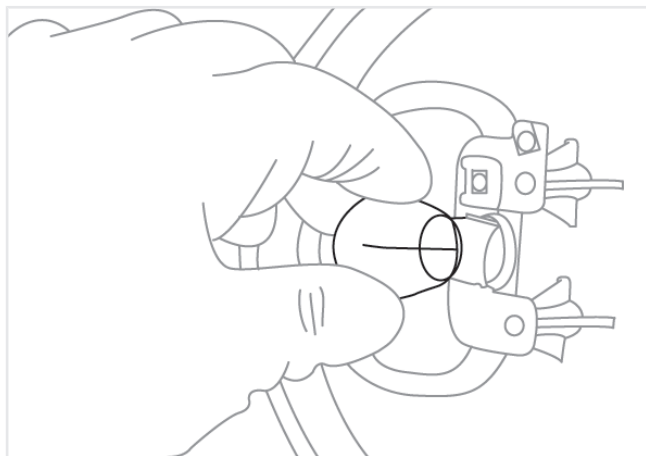

Figure: 150302-1

#### Direction indicator bulb replacement

- Press the top of the bulb (fig. 150302-1).
- Turn the bulb, keeping it pressed, to release it from the lock.
- Perform the same procedure to insert the new bulb.

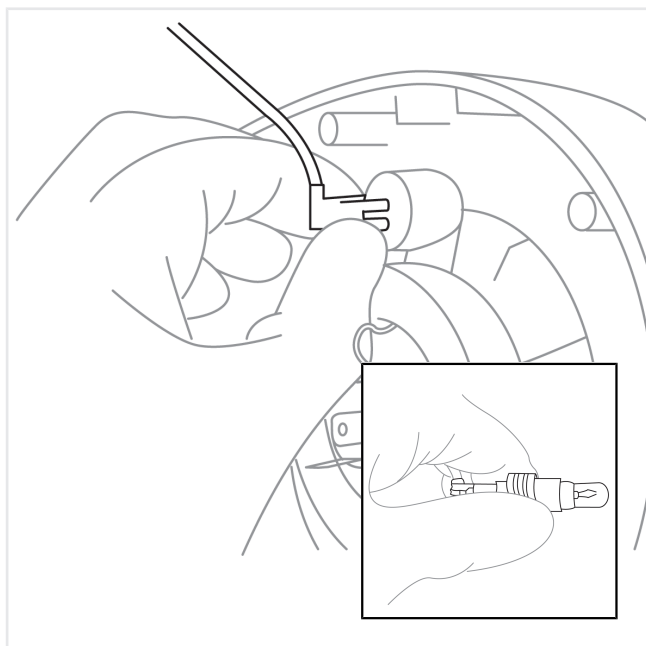

Figure: 150302-2

#### Sidelight bulb replacement

- Grasp the rear part where the electrical connections are placed (fig. 150302-2).
- Turn and pull the rear part towards you.
- Extract the support, press the top of the bulb.
- Turn the bulb, keeping it pressed, to release it from the lock.
- Perform the same procedure to insert the new bulb. Put back the support inside its seat.

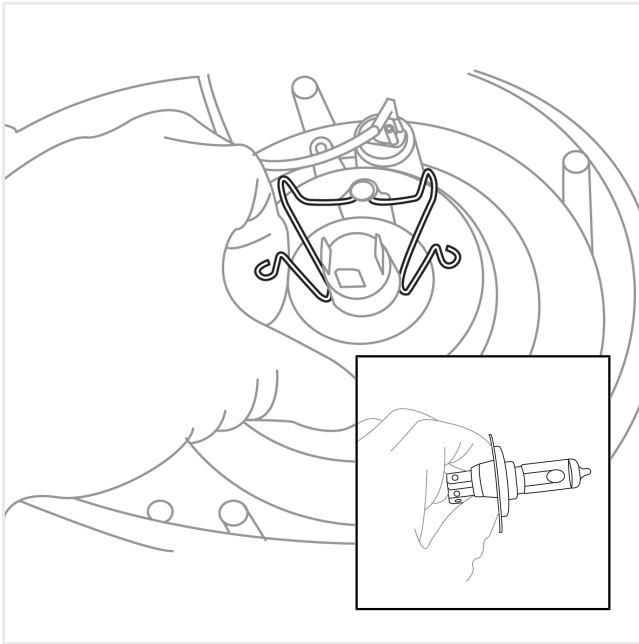

Figure: 150302-3

**Low/high beam light bulb replacement**

- Remove the electrical connector pulling it towards you.
- Lift the locking tabs (fig. 150302-3) moving them sideways to release the bulb.
- After replacing the bulb, proceed in the reverse order to lock and connect it again. Observe the joints of the lamp for proper insertion.

**11.17.2 - Tail light**

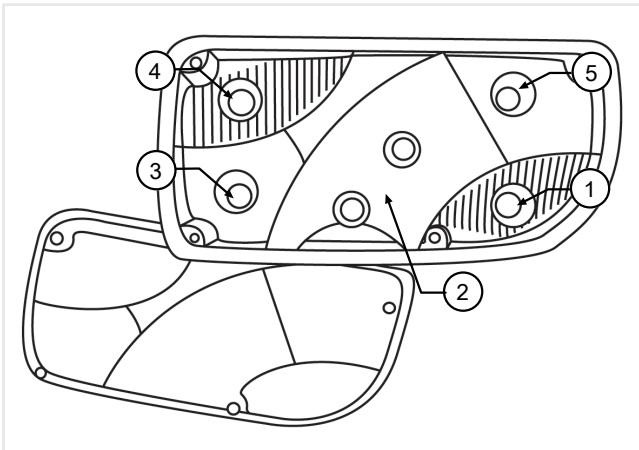

Figure: 120304-1

- 1 Reversing light - 21 W
- 2 Rear side light- 5 W
- 3 Braking light - 21 W
- 4 Direction indicator - 21 W
- 5 Rear fog light - 21 W

To access the bulbs:

1. Prepare the vehicle in the maintenance position.
2. Turn off the battery isolation switch to disconnect power to the electrical system.
3. Remove the power supply connector on the back of the light.
4. Remove the front of the headlight by loosening the screws placed in the cap.

To close the headlight operate in the reverse order, paying attention to correct positioning of the sealing gasket.

**Tail light bulb replacement.**

- Press the top of the bulb.
- Turn the bulb, keeping it pressed, to release it from the lock.
- Perform the same procedure in reverse order to insert the new bulb.

**11.17.3 - Work light \***



**NOTE**

\* The work light is an optional accessory.

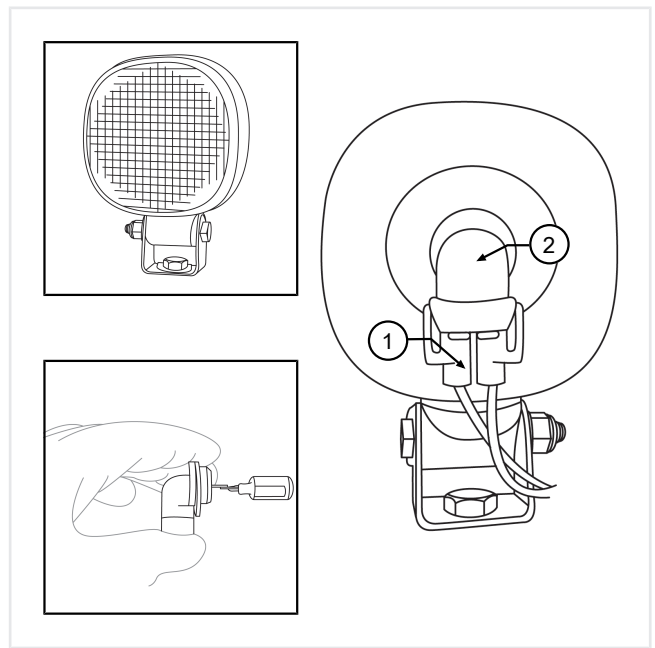

Figure: 150305-1

**Work light bulb replacement**

To access the bulbs (fig. 150305-1):

- Prepare the vehicle in the maintenance position.
- Turn off the battery isolation switch to disconnect power to the electrical system.
- Remove the power connector at the back of the light "1".
- Press the connector socket on the light "2".

- Turn the socket, keeping it pressed, to release it from the lock.

Perform the same procedure in reverse order to insert the new bulb.

### 11.17.4 - Led work light\*



#### NOTE

\* The LED work light is an optional accessory.

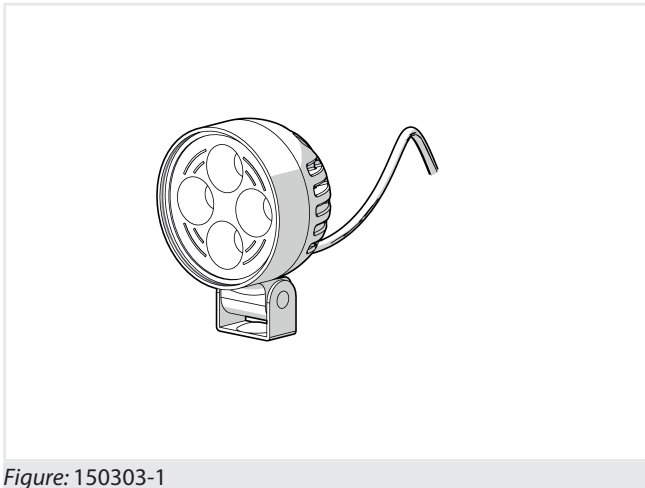

Figure: 150303-1

The LED work light (fig. 150303-1) does not require maintenance.

## 11.18 - Window washer fluid tank

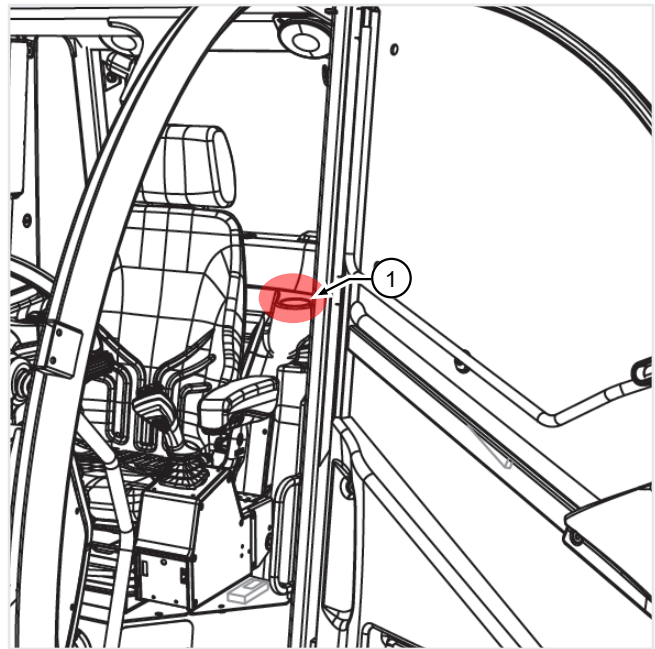

Figure: 150466-1

The washer fluid tank is located in the cab on the left side of the seat "1" (fig. 150466-1).

To add liquid to the tank:

- Remove the filling cap.
- Add washing fluid to fill the tank.
- Put back the cap.



#### ATTENTION

During the winter, mix antifreeze fluid to the water.

## 11.19 - Ventilation system maintenance

### 11.19.1 - Cab ventilation filter: Cleaning and replacement

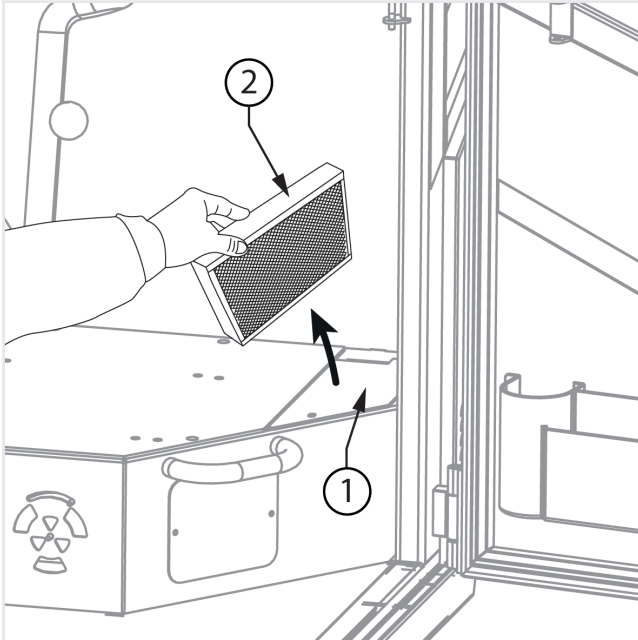

Figure: 150944-1

When changing the cab ventilation filter, clean the suction duct with a jet of air from inside the cab to the outside.

- Prepare the vehicle in the maintenance position.
- Remove the housing "1" (fig. 150944-1), located on the left part of the seat, unscrewing the fixing screw.
- Remove the filter "2".
- Replace or clean the filter cartridge by tapping gently on a flat surface, with the outer side facing down, being careful not to damage it; or use a jet of air (less than 6.9 bar) by blowing from the inside to the outside.
- Refit the filter "2".
- Put the housing back in place "1".
- Restart the engine with the fan in motion to verify the correctness of the operations.

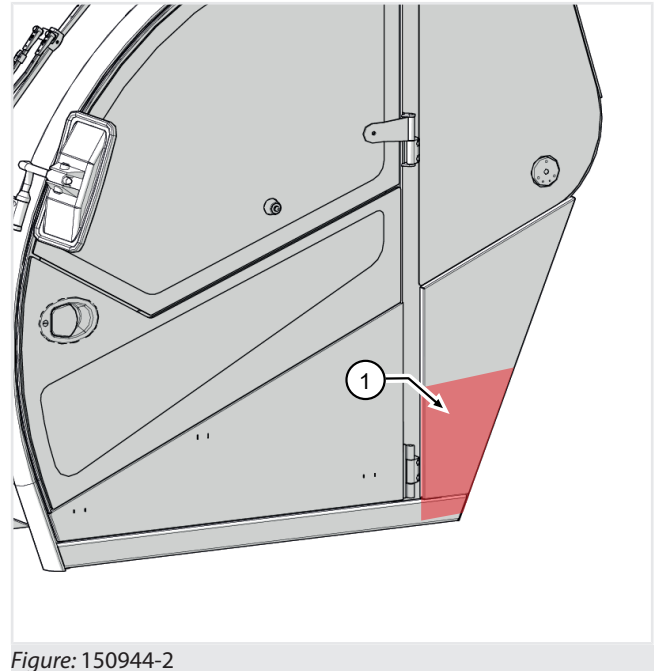

Figure: 150944-2

Clean the air intake grid (fig. 150944-2) at the end of every working day using a jet of air.



#### DANGER

Do not use diesel fuel, gasoline, solvents or water to clean the cartridges, as this may damage the filtering material.



#### WARNING

If the vehicle is used in environments particularly rich of dust (barns, etc.), the filter life is reduced to 100 hours.



#### WARNING

**In case of malfunction of the ventilation system, check the filter clogging.**

In the event that the malfunction continues despite the filter replacement, contact DIECI service center.



#### DANGER

**Do not use the vehicle without a cab filter.**

The entry of dust into the cab may involve risks to the health of the operator and breakage of the ventilation system.

### 11.19.2 - Air conditioning: Cleaning \*



#### NOTE

Air conditioning is an optional accessory.

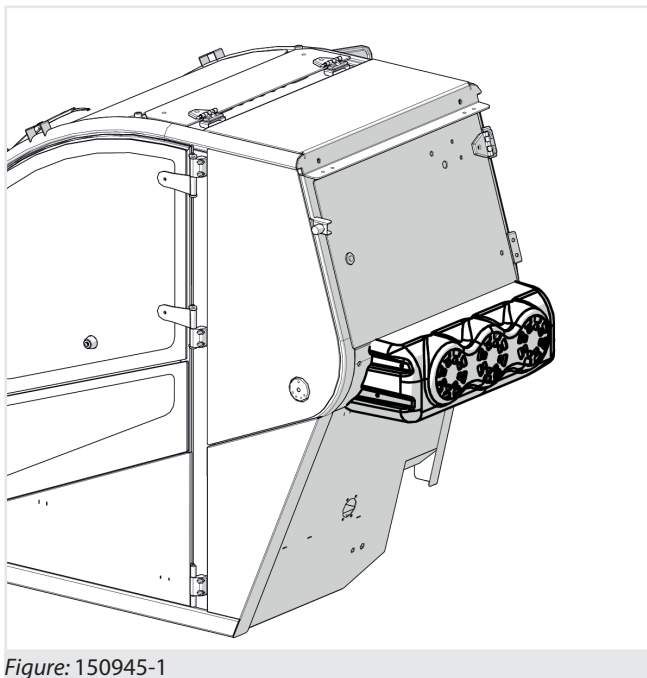

Figure: 150945-1

- Prepare the vehicle in the maintenance position.
- Remove the protection housing (fig. 150945-1).
- Clean the air conditioning radiator directing compressed air at a maximum pressure of 7 bar, from the top downwards, in the direction opposite to that of the normal flow of air. The air flow must be perpendicular to the radiator surface.
- Remove dirt from under the air conditioning radiator.
- After cleaning, refit the condenser.



#### ATTENTION

**Be careful not to damage the radiator fins while cleaning.**

Check that the fins are not deformed; in that case straighten with caution.

## 11.20 - Boom maintenance

### 11.20.1 - Sliding blocks maintenance

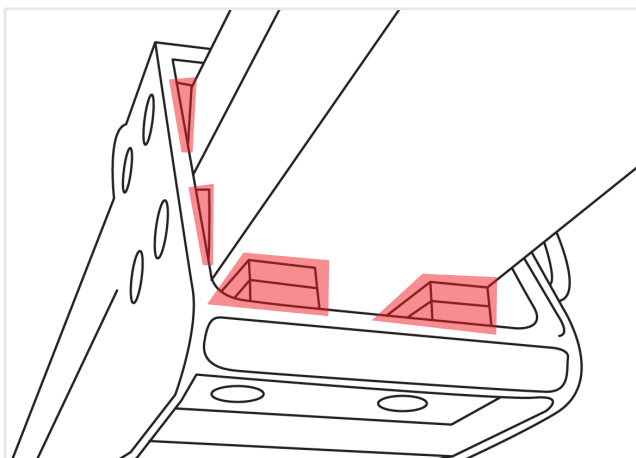

Figure: 150571-1

Worn sliding blocks can lead to oscillations and clearances between one extension and the other with consequent loss of precision in the movements and danger of load falling.

- For the deadlines see the summary table at the beginning of the chapter.
- With severe working conditions the wear is greater.



#### ATTENTION

Maintenance to the telescopic boom sliding blocks must be performed by authorized **DIECI** service.

### 11.20.2 - Boom lubrication with grease

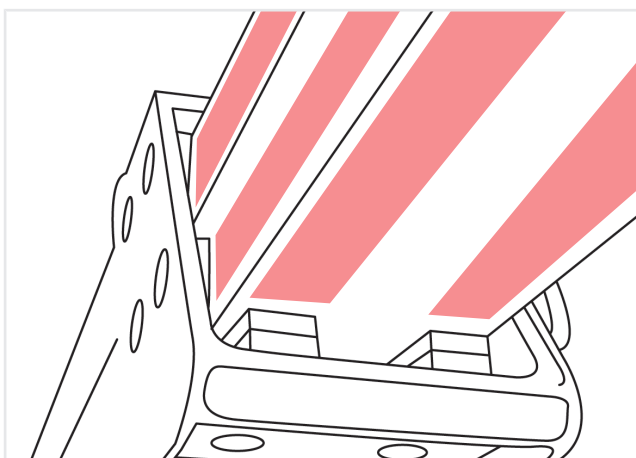

Figure: 150572-1



The boom sliding blocks must be kept lubricated to prevent as much as possible the deterioration and maintain soft movements.

- If the grease layer is thin or if impurities (sand, dust, shavings, etc ...) are present, proceed as follows:
- Prepare the vehicle in the maintenance position.
- Turn on the vehicle.
- Fully extend the boom and keep it in horizontal position.
- Turn off the engine and remove the ignition key, place a sign in the cab showing "maintenance in progress".
- Disconnect the battery using the battery cut-off switch.
- Remove the layer of grease and impurities on the surface of the extensions with a cloth.
- Use a brush to apply a layer of approved type grease on all four sides of the extensions.
- Turn on the vehicle.
- Fully retract and extend the boom several times to evenly distribute the grease.
- Turn off the vehicle.
- Remove excess grease.



**ATTENTION**

Use only lubricants recommended by *DIECI*, different lubricants may cause severe damage to the sliding surfaces.



**WARNING**

During the grease visual check and application the vehicle must be turned off and the key removed from the cab to avoid accidental operation.



**NOTE**

**See the "Maintenance Log" chapter to know the maintenance intervals timing.**

When using the vehicle in severe conditions, very dusty environment requires a more frequent greasing.

**11.21 - Cylinders block valves maintenance**

The block valves for cylinders prevent uncontrolled movement of the pistons of the cylinders in the event of hydraulic pressure failure or bursting of a hose.

The valves are installed directly on the cylinders.



**DANGER**

**During the checking operations do not allow any person to stay within the radius of action of the vehicle.**

Check the valves individually.

In case of malfunction do not use the vehicle until it has been repaired.

Boom lifting cylinders:

- Start the engine. Make sure that the parking brake is engaged and the transmission is in neutral.
- Lift the boom to approximately 45°.
- With the engine running at 1400 rpm, lower the boom. During the boom movement stop the engine.

The boom movement must slow down and then stop when the engine slows down and stops.



**DANGER**

**If the boom continues to move after stopping the engine, the lifting cylinders block valve is faulty.**

Remove the fault as soon as possible, contact the *DIECI* service center.

Boom extension cylinder:

- Start the engine. Make sure that the parking brake is engaged and the transmission is in neutral.
- Lift and fully extend the boom.
- With the engine running at 1400 rpm, retract the boom. During the boom movement stop the engine.

The boom movement must slow down and then stop when the engine slows down and stops.

**DANGER**

**If the boom continues to move after stopping the engine, the extension cylinders block valve is faulty.**

Remove the fault as soon as possible, contact the **DIECI** service center.

## Forks tilting cylinders:

- Start the engine, take a load on the forks (for example, a load of bricks or some bales of hay).
- Tilt the forks fully upward.
- Engage the parking brake and set the transmission into neutral.
- Tilting the boom away from the ground sufficiently to allow the forks to tilt forward.
- With the engine running at 1400 rpm, operate the control lever to tilt the plate forward. During the forks movement stop the engine.

The tilting movement must slow down and then stop when the engine slows down and stops.

**DANGER**

**If the forks continue to move after stopping the engine, the tilting cylinders block valve is faulty.**

Remove the fault as soon as possible, contact the **DIECI** service center.

## Leveling and oscillating block cylinders (if any):

- Position the vehicle on a perfectly horizontal surface.
- Make sure that the parking brake is engaged and the transmission is in neutral.
- Make sure the vehicle is in carriage mode.
- Lift the boom about 15 cm from the ground and level the vehicle so that the chassis is perfectly parallel to the surface (check the level in the cab).
- Check that, without intervening on the leveling control, the vehicle maintains this position even after a prolonged use.

**DANGER**

**If the chassis continues to move after stopping the engine, the leveling cylinders block valve is faulty.**

Remove the fault as soon as possible, contact the **DIECI** service center.

**NOTE**

Do not level the vehicle with boom raised and/or removed.

## Outriggers cylinders (if present)

- Start the engine. Make sure that the parking brake is engaged and the transmission is in neutral.
- Place the vehicle on outriggers.
- Level the vehicle with the outriggers.
- Fully extend the boom.
- With the engine running at idle speed, rotate the vehicle turret.

**DANGER**

**If the outriggers continue to move after stopping the engine, the outriggers cylinders block valve is faulty.**

Remove the fault as soon as possible, contact the **DIECI** service center.

## 11.22 - Differential Axles Maintenance

### 11.22.1 - Differential axles oil: Check and replacement

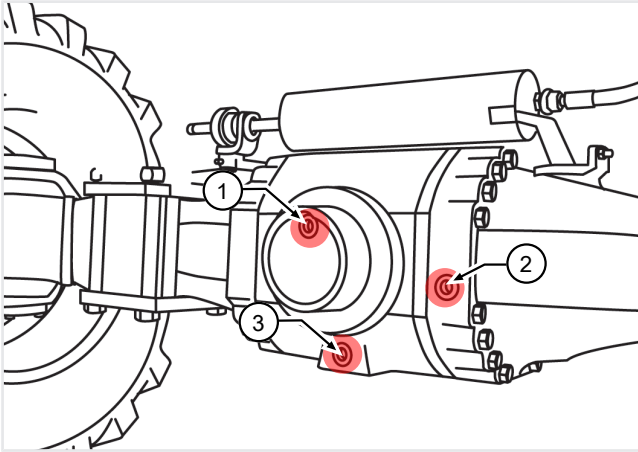

Figure: 150579-1

The filler, level and drain caps are located in the central part of the front and rear differential axle (fig. 150579-1):

**When checking the oil level it is necessary to:**

- Prepare the vehicle in the maintenance position.
- Place a container for the oil recovery under the level plug "2" to collect any leaks.
- Open the level cap "2". In the best conditions oil must seep out from the hole.
- If necessary, open the cap "1" and top up to make oil seep out from the level cap "2".
- Put back the caps and tighten down.

**When replacing the oil it is necessary to:**

- Prepare the vehicle in the maintenance position.
- Place a container for the oil recovery under the drain plug "3" to collect any leaks.
- Open the filler cap "1" and then the drain cap "3".
- Drain off all the oil.
- Close the drain plug "3".
- Load new oil from the filler cap "1", up to make oil seep out from the level cap "2".

Put back the caps and tighten down.



### WARNING

**Replace oil in the differential axles after the first 100 hours of use.**

Failure to replace the running-in oil will compromise the correct operation of the differential axles

## 11.23 - Hydraulic fittings tightening torques

### Inserts with 60° nose - BSP thread

Thread	1/18.28	1/4.19	3/8-19	1/2-14	5/8-14	3/4-14	1"-11	1"1/4-11	121/2-11
(N·m)	12-14	14-16	25-28	45-60	55-70	90-110	120-140	170-190	200-245

### Inserts with 60° nose - METRIC thread

Thread	10x1	12x1.5	14x1.5	16x1.5	18x1.5	22x1.5	26x1.5	28x1.5	30x1.5
(N·m)	12-14	13-15	15-18	25-28	27-30	50-60	60-75	80-100	110-130

### SERIES DIN RANGE „L“

Thread	12x1.5	14x1.5	16x1.5	18x1.5	22x1.5	26x1.5	30.2	36x1.5	45x1.5	52x1.5
(N·m)	13-15	15-18	25-28	27-30	50-60	30-75	85-105	120-140	170-190	190-230

### SERIES DIN RANGE „S“

Thread	14x1.5	16x1.5	18x1.5	20x1.5	22x1.5	24x1.5	30x2	36x2	42x2	52x2
(N·m)	15-18	25-28	27-30	43-54	50-62	60-75	90-110	125-145	170-190	200-245

# 11.24 - Torque specifications - fasteners

## 11.24.1 - Torque specifications - fasteners: Fine pitch

	Coefficient of friction	4.8		5.8		6.8		8.8		10.9		12.9	
		Preload (N)	Tightening torque: (Nm)	Preload (N)	Tightening torque: (Nm)	Preload (N)	Tightening torque: (Nm)	Preload (N)	Tightening torque: (Nm)	Preload (N)	Tightening torque: (Nm)	Preload (N)	Tightening torque: (Nm)
<b>M8</b>	0.10	9798	10.87	12248	13.59	14697	16.31	19596	21.75	27557	30.58	33069	36.70
	0.14	9080	13.53	11349	16.91	13619	20.29	18159	27.05	25536	38.04	30643	45.65
<b>M10</b>	0.10	15297	21.13	19121	26.41	22945	31.69	30594	42.25	43023	59.42	51627	71.30
	0.14	14175	26.27	17719	32.84	21263	39.41	28350	52.55	39867	73.89	47841	88.67
<b>M10</b>	0.10	16384	22.12	20480	27.66	24575	33.19	32767	44.25	46079	62.23	55295	74.67
	0.14	15222	27.80	19027	34.75	22833	41.70	30443	55.61	42811	78.20	51373	93.84
<b>M12</b>	0.10	22021	35.83	27526	44.79	33031	53.75	44041	71.67	61933	100.78	74320	120.94
	0.14	20406	44.53	25507	55.66	30609	66.79	40812	89.06	57391	125.24	68870	150.29
<b>M12</b>	0.10	23334	37.26	29167	46.57	35001	55.88	46667	74.51	65626	104.78	78751	125.74
	0.14	21669	46.70	27087	58.38	32504	70.06	43338	93.41	60945	131.36	73134	157.63
<b>M14</b>	0.10	31610	59.04	39513	73.80	47415	88.57	63220	118.09	88903	166.06	106684	199.27
	0.14	29346	73.92	36682	92.40	44019	110.89	58692	147.85	82535	207.91	99043	249.49
<b>M16</b>	0.10	42581	89.78	53227	112.23	63872	134.67	85163	179.56	119760	252.51	143712	303.02
	0.14	39588	113.06	49485	141.32	59382	169.59	79176	226.12	111341	317.98	133609	381.57
<b>M18</b>	0.10	51457	124.03	64322	155.03	77186	186.04	102914	248.06	144723	348.83	173668	418.59
	0.14	47752	155.02	59690	193.78	71628	232.53	95503	310.05	134302	436.00	161162	523.20
<b>M18</b>	0.10	55415	130.17	69269	162.72	83123	195.26	110830	260.35	155855	366.12	187026	439.34
	0.14	51578	164.67	64472	205.84	77366	247.01	103155	329.35	145062	463.15	174075	555.77
<b>M20</b>	0.10	65534	173.72	81918	217.16	98301	260.59	131068	347.45	184315	488.60	221178	586.32
	0.14	60886	218.17	76108	272.71	91329	327.26	121772	436.34	171243	613.61	205491	736.33
<b>M20</b>	0.10	70115	181.58	87643	226.97	105172	272.36	140229	363.15	197198	51.68	236637	612.82
	0.14	65319	230.55	81649	288.19	97979	345.82	130638	461.10	183710	648.42	220452	778.10

	Coefficient of friction	4.8		5.8		6.8		8.8		10.9		12.9	
		Preload (N)	Tightening torque: (Nm)	Preload (N)	Tightening torque: (Nm)	Preload (N)	Tightening torque: (Nm)	Preload (N)	Tightening torque: (Nm)	Preload (N)	Tightening torque: (Nm)	Preload (N)	Tightening torque: (Nm)
<b>M22</b>	0.10	81221	236.88	101526	296.10	121831	355.32	162442	473.76	228433	666.23	274120	799.48
	0.14	75534	298.75	94417	373.43	113301	448.12	151068	597.49	212439	840.22	254927	1008.27
<b>M22</b>	0.10	86164	246.02	107705	307.53	129246	369.04	172329	492.05	242337	691.94	290804	830.33
	0.14	80332	313.41	100415	391.76	120498	470.11	160664	626.82	225933	881.46	271120	1057.75
<b>M24</b>	0.10	98516	308.56	123145	385.70	147773	462.84	197031	617.12	277075	867.83	332490	1041.40
	0.14	91693	390.33	114617	487.92	137540	585.50	183387	780.67	257887	1097.82	309465	1317.38
<b>M24</b>	0.10	104079	319.62	130099	399.52	156119	479.43	208152	639.23	292723	898.92	351268	1878.71
	0.14	97096	408.12	121370	510.15	145644	612.18	194192	816.24	273083	1147.84	327699	1377.41
<b>M27</b>	0.10	127922	448.43	159903	560.54	191884	627.65	255845	896.87	359782	1261.22	431738	1513.46
	0.14	119185	569.67	148981	712.09	178778	854.51	238370	1139.34	335208	1602.20	402250	1922.64
<b>M30</b>	0.10	16818	623.80	201022	779.75	241226	935.70	321635	1247.60	452299	1754.43	542759	2105.32
	0.14	149957	795.14	187446	993.93	224936	1192.72	299914	1590.29	421754	2236.34	506105	2683.61

### 11.24.2 - Torque specifications - fasteners: Coarse pitch

	Coefficient of friction	4.8		5.8		6.8		8.8		10.9		12.9	
		Preload (N)	Tightening torque: (Nm)	Preload (N)	Tightening torque: (Nm)	Preload (N)	Tightening torque: (Nm)	Preload (N)	Tightening torque: (Nm)	Preload (N)	Tightening torque: (Nm)	Preload (N)	Tightening torque: (Nm)
<b>M3</b>	0.10	1220	0.54	1525	0.68	1830	0.82	2440	1.09	3431	1.53	4117	1.84
	0.14	1126	0.60	1407	0.83	1689	1.00	2252	1.34	3167	1.88	3800	2.26
<b>M3.5</b>	0.10	1638	0.84	2048	1.05	2457	1.26	3276	1.68	4608	2.36	5529	2.84
	0.14	1511	1.03	1889	1.28	2267	1.54	3023	2.05	4251	2.89	5101	3.47
<b>M4</b>	0.10	2115	1.25	2644	1.56	3173	1.88	4231	2.50	5950	3.52	7140	4.22
	0.14	1951	1.53	2439	1.91	2926	2.29	3902	3.06	5487	4.30	6584	5.16
<b>M5</b>	0.10	3462	2.46	4327	3.08	5192	3.70	6923	4.93	9736	6.93	11683	8.32
	0.14	3197	3.02	3996	3.78	4795	4.53	6394	6.04	8991	8.50	10789	10.20
<b>M6</b>	0.10	4875	4.24	6093	5.30	7312	6.35	9749	8.47	13710	11.92	16452	14.30
	0.14	4499	5.19	5624	6.48	6749	7.78	8998	10.37	12654	14.59	15184	17.51
<b>M7</b>	0.10	7135	6.97	8918	8.71	10702	10.45	14269	13.94	20066	19.60	24079	23.52
	0.14	6600	8.60	8250	10.76	9899	12.90	13199	17.21	18561	24.20	22274	29.04
<b>M8</b>	0.10	8947	10.20	11184	12.75	13421	15.30	17894	20.41	25164	28.70	30197	34.44
	0.14	8266	12.54	10332	15.67	12398	18.80	16531	25.07	23247	35.26	27897	42.31
<b>M10</b>	0.10	14245	20.11	17806	25.14	21367	30.16	28489	40.22	40063	56.56	48075	67.87
	0.14	13167	24.76	16459	30.95	19751	31.14	26335	49.52	37033	69.64	44440	83.56
<b>M12</b>	0.10	20767	34.43	25958	43.03	31150	51.64	41533	68.86	58406	96.83	70087	116.20
	0.14	19204	42.42	24005	53.03	28806	63.63	38408	84.84	54011	119.31	64814	143.17
<b>M14</b>	0.10	28390	54.77	35487	68.46	42585	82.15	56780	109.53	79847	154.03	95816	184.84
	0.14	26261	67.56	32827	84.45	39392	101.34	52522	135.13	73860	190.02	88632	228.03
<b>M16</b>	0.10	39242	85.14	49053	106.43	58863	127.72	78484	170.29	110369	239.47	132442	287.36
	0.14	36364	105.80	45455	132.26	54546	158.71	72729	211.61	102274	297.58	122729	357.09
<b>M18</b>	0.10	47533	117.48	59416	146.85	71300	176.22	95066	234.96	133687	330.41	160424	396.49
	0.14	43986	145.16	54983	181.45	65979	217.74	87972	290.32	123711	402.26	148453	489.92
<b>M20</b>	0.10	61238	166.08	76548	207.61	91857	249.13	122476	332.17	172232	467.11	206678	560.54

	Coefficient of friction	4.8		5.8		6.8		8.8		10.9		12.9	
		Preload (N)	Tightening torque: (Nm)	Preload (N)	Tightening torque: (Nm)	Preload (N)	Tightening torque: (Nm)	Preload (N)	Tightening torque: (Nm)	Preload (N)	Tightening torque: (Nm)	Preload (N)	Tightening torque: (Nm)
	0.14	56747	206.39	70934	257.98	85121	309.58	113494	412.78	159601	580.47	191522	696.56
<b>M22</b>	0.10	76305	227.22	95382	284.02	114458	340.82	152610	454.43	214608	639.05	257530	766.85
	0.14	70792	283.79	88490	352.74	106188	425.69	141584	567.58	199102	798.16	238923	957.80
<b>M24</b>	0.10	88232	287.16	110291	358.94	132349	430.73	176465	574.31	248154	807.63	297784	969.15
	0.14	81762	356.84	102202	446.05	122643	535.26	163524	713.68	229955	1003.61	275946	1204.33
<b>M27</b>	0.10	115779	420.40	144724	525.05	173668	930.06	231558	840.08	325628	1181.36	390753	1417.63
	0.14	107442	525.08	134302	656.35	161162	787.62	214883	1050.16	302179	1476.79	362615	1772.15
<b>M30</b>	0.10	141000	572.83	176249	716.03	211499	859.24	281999	1145.65	396561	1611.08	475873	1933.29
	0.14	130771	714.49	163463	893.11	196156	1071.73	261541	1428.97	367792	2009.49	441351	2411.39



Local Dealers can supply original spare parts as well as advice and instructions for their installation and use.

Use only original spare parts when they are required.

The use of non-original spare parts may cause damage to other parts of the vehicle. Customers are advised to purchase all original spare parts required only from an authorized Agent or Dealer.

**DIECI s.r.l.** does not consider itself liable for damage deriving from the use of non-original spare parts.

## 12.1 - Spare parts supply

**DIECI s.r.l.** guarantees the supply of original spare parts or alternatives for 10 years from the date of the last model produced of the series concerned.

## 12.2 - Assistance to owner / operator

In order to obtain a good service from your Dealer, please obtain of these fundamental data before contacting the service center:

1. Specify your name, address and telephone number.
2. Indicate the model and serial number of the vehicle chassis.
3. Indicate the date of purchase and the hours of operation.
4. Explain the nature of the fault.

Note that only DIECI Dealers can access the resources at DIECI site for customer service. Moreover, they are able to offer a variety of programs with regard to warranty, maintenance at a fixed price, safety checks, including tests

## 12.3 - Technical Assistance Service address

### Dieci Technical Assistance Service

Via E. Majorana, 2/4

42027 Montecchio Emilia (RE) ITALY

Tel. +39 0522 869611

Fax +39 0522 869744

service@dieci.com



## WARNING

The interventions for the elimination of faults can only be carried out by trained personnel.

Do not work on failures if the "Safety regulations", "Safe Working Procedures" and "MAINTENANCE" have not been read and understood before.





This symbol indicates that the trouble experienced may NOT be resolved without the intervention of a **DIECI** Service authorized workshop



## 13.1 - Engine

PROBLEM	CAUSE	SOLUTION	
It does not set in motion	Direction of travel lever engaged	Place the lever in neutral	
	Parking brake deactivated	Activate it	
	No fuel	Fill the tank	
	Battery isolation switch disconnected	Connect the battery isolation switch	
	Low Battery	Recharge the battery or replace it	
	Fuse failure	Replace the fuse	
	Other	Consult the Use and Maintenance manual of the engine	



## 13.2 - Hydraulic transmission system

PROBLEM	CAUSE	SOLUTION	
The vehicle does not go in any direction	Insufficient hydraulic oil level	Check the hydraulic oil level	
	Hand throttle engaged	Release the hand throttle	
	The sensor built-in the seat does not report the presence of the operator	Sit properly at the driver's seat	
	The movement selection lever is not engaged	Engage the lever to the desired position	
	The outriggers are lowered (if installed)	Raise all outriggers fully up	
	Parking brake in operation	Disengage the brake	
	Electrical circuit failure	Repair the circuit	
	Hydrostatic transmission failure	Repair or replace the transmission	
The vehicle loses speed	The transmission ByPass tap has been opened (if installed)	Close the ByPass tap	
	Hydraulic oil intake filter clogged	Remove the oil filter and replace it	
	Inching pedal failure	Check the correct operation of the pedal and the valve	



### 13.3 - Brakes

PROBLEM	CAUSE	SOLUTION	
The vehicle does not brake	Lack of oil in the oil - brakes tank	Refill the tank and / or Purge the system	
	Loss of fluid from the circuit	Check for leaks	
	Brake discs worn	Replace the brake discs	
	Brake master cylinder failure	Repair or replace	
	Unsuitable fluid in the circuit or in the differential sump	Check the brake oil specifications indicated	

### 13.4 - Steering wheel

PROBLEM	CAUSE	SOLUTION	
The vehicle runs sideways The wheels are not aligned	The wheels are not correctly aligned	Align them	
	Steering selection error	Put back the lever in a different steering mode	
	Control distributor failure	Repair or replace the distributor	
	Leakage from the steering wheel hydraulic cylinders	Replace the gaskets	

### 13.5 - Telescopic boom

PROBLEM	CAUSE	SOLUTION	
The vehicle does not lift the load	They safety systems have activated	See the "Anti-tipping device" chapter	
	Electrical system failure	Check the fuses and electrical system	
	Hydraulic oil level in the tank insufficient	Top up	
	Relative hydraulic pump failure	Repair or replace the pump	
	Distributor low calibration	Check and re-calibrate the distributor	
	Lifting cylinders internal leak	Replace the gaskets	
The boom does not extend	"The safety systems have activated (Indicator light and audible alarm in operation)"	See the "Anti-tipping device" chapter	

PROBLEM	CAUSE	SOLUTION	
The boom does not come down	"The safety systems have activated (Indicator light and audible alarm in operation)"	See the "Anti-tipping device" chapter	

Cleaning the vehicle and all its components is fundamental for it to be kept in proper working order.

## 14.1 - Vehicle cleaning

Proceed as follows for a correct cleaning process:

- Switch the engine off, remove the ignition key and wait until the various components cool down.
- Wear the suitable protective clothing (gloves, masks, overalls, etc.).
- Do not use flammable liquids, acids or products that may chemically attack the vehicle components.
- Use water to soften dirt that sticks to the surface.
- Ask your **DIECI** dealer for touch-up paint to repair minor defects in the vehicle bodywork.
- Check that all the safety stickers are present. Replace any that have been lost or removed for cleaning purposes.
- Use a pressure washer to clean the external part of the vehicle and the engine compartment, bearing the following in mind:
  - Make sure the top-up caps (radiator, oil tank, fuel tank, etc.) are closed well.
  - Protect the control boxes and connectors from water infiltrations.
  - Do not operate with a pressure and water temperature that exceeds 100 bar and 80°, respectively.
  - Hold the washer nozzle at a minimum distance of 40 cm from the relative surface.
  - Do not direct the jet at any single point but wash with wide strokes.
  - The inside of the vehicle is delicate and cannot be cleaned with a pressure washer.

### Electrical components

- If a pressurized jet is used, try not to wet the electrical components, such as the alternator and the starter motor.
- If water accidentally falls into the electrical system, it could cause the vehicle to malfunction.
- Do not use water or steam to clean the electrical system, sensors and connectors.

### Mechanical Components

- Do not clean the moving elements or hot surfaces, allow all parts to cool as a temperature change could damage them.

## 14.2 - Glasses cleaning

- The cab windows, lights and wing mirrors must be washed often with soapy water.
- After washing has been completed, dry thoroughly; do not leave any stains or marks which may limit or obstruct the driver's visibility.

## 14.3 - Cleaning the cab

- Clean soft upholstery in the cab with a cloth that has been dipped in a solution of water and detergent and then thoroughly wrung.
- The driver's seat and the floor must be cleaned with a vacuum cleaner and/or a stiff brush. If necessary, use a damp cloth to remove any stubborn stains.
- Clean the seat belt with a sponge that has been soaked in hot soapy water, and let it dry on its own.
- Fabric-covered seats must be cleaned with a stiff brush or vacuum cleaner. Plastic seats must be cleaned with a damp cloth.



### WARNING

#### Pay attention to electrical components.

Do not use water jets inside the cab.



### WARNING

Do not use products containing alcohol to clean the interior lining of the cab.

## 14.4 - Safety stickers cleaning



### ATTENTION

To ensure proper interpretation verify that they are in the correct position and that they are always kept clean.

Clean the safety stickers when they are dirty, covered with mud, concrete or debris.



### WARNING

**It is absolutely forbidden to clean the messages on the vehicle and equipment using solvents or gasoline.**

The labels may become discolored. The labels in addition to those of care and safety must always be treated in the same way.

**DANGER**

**Always check the good condition of the anchors (ropes, chains, wedges, etc...).**

Make sure that the lifting equipment is adequate for the weight of the vehicle to be lifted.

**NOTE!** The weight and dimensions of the vehicle are shown in the “Technical data” chapter; check the overall dimensions for the maximum and minimum height values from the ground and the weight allowed.

The vehicle is fitted with lifting points, marked by special symbols (fig. 150522-1).

Attach the ropes at the points indicated in the figure, paying utmost attention during the lifting phases. Slowly proceed with the lifting.

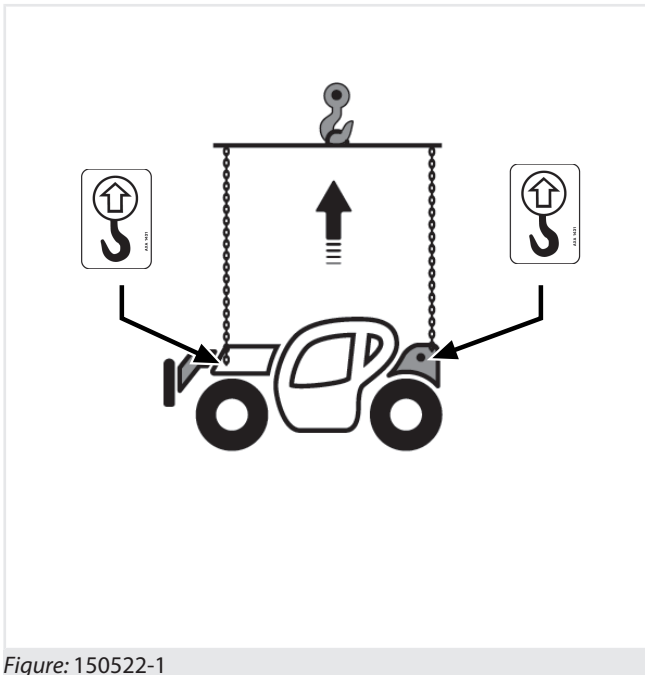

Figure: 150522-1

**DANGER**

Before lifting the vehicle, make sure no unauthorized personnel are in the surrounding area.

**ATTENTION**

Lifting cables with a minimum unit capacity of 6 tons (13220 lb) are required.

Before lifting the vehicle, make sure to:

- Remove any attachments installed on the vehicle.

- Retract and lower the telescopic boom completely.
- Engage the parking brake, place and the movement selection lever at “N” and switch off the vehicle.
- Close all windows and the cab door.



**WARNING**

Always check the good condition of the anchors (ropes, chains, wedges, etc...).

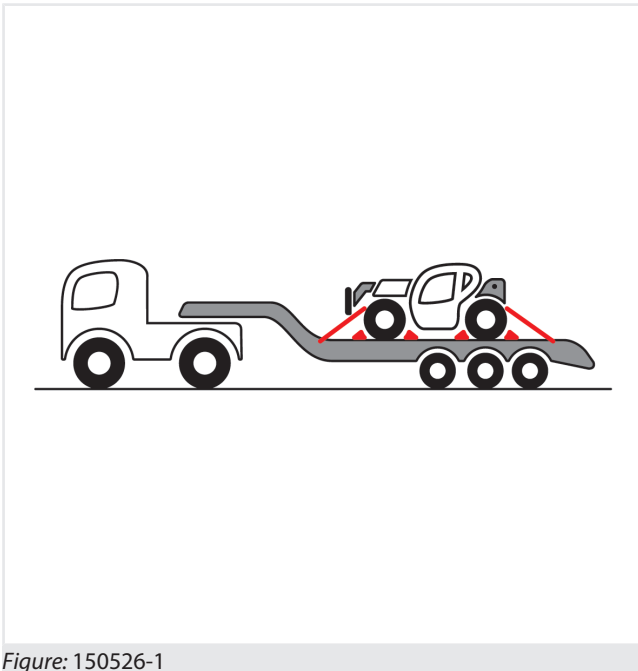

Figure: 150526-1

**NOTE!** The weight and dimensions of the vehicle are shown in the “Technical data” chapter; check the overall dimensions for the maximum and minimum height values from the ground and the weight allowed.

Pay attention to the following when loading the vehicle onto a trailer:

- Before using ramps or trailers to load the vehicle on, remove any mud, ice or oil that could cause accidents.
- Check that the axle and the transport vehicle can withstand the overall weight of the vehicle and any loaded equipment.
- Check the overall dimensions of the vehicle for minimum and maximum heights from the ground and the weight allowed.
- Carefully handle the vehicle onto the transport vehicle.
- Make sure local regulations are observed when transporting the vehicle on public roads.



**DANGER**

When loading or unloading a vehicle from a transport vehicle, there is always the risk of the vehicle overturning sideways; therefore, have another person on the ground to control the operations.

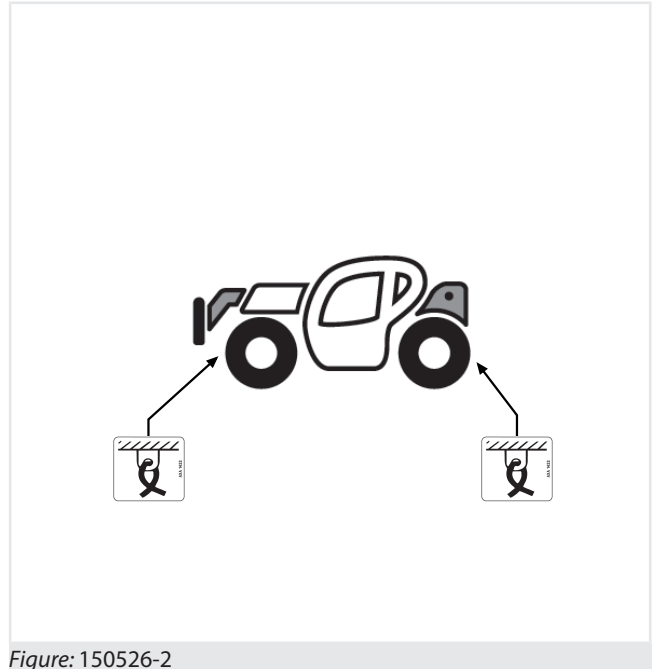

Figure: 150526-2

Take the following precautions when loading or unloading a vehicle:

1. Choose solid and level ground.
2. Remove any attachments installed on the vehicle.
3. Lower and fully retract the telescopic boom
4. Use a platform or a ramp.
5. Always select the slowest speed.
6. Load the vehicle on to the transport vehicle, making sure that the ramps are positioned properly and safely.
7. Once the vehicle is in a safe position, switch the engine off and engage the parking brake.
8. Close all windows and the cab door.
9. Anchor the vehicle to the transport vehicle with chains or cables through the relative hooks (fig. 150526-2).
10. Apply wedges to the front and rear wheels of the transport vehicle.

## 17.1 - Long period of inactivity

If the vehicle must be stored for a long period of time (over a week), certain precautions must be complied with to protect it:

- Clean the vehicle.
- Lubricate all the lubricators.
- Check the tires and inflate them to the recommended pressure.
- Clean the fuel system and change the filter cartridges.
- Store any equipment.
- Use the battery isolation switch to deactivate the electrical circuit.
- Realign and lower all the mobile parts of the vehicle completely.
- Close and lock all the windows.
- Close and lock the door.

## 17.2 - Long period of inactivity

If the vehicle must be stored for a long period (more than two months), certain precautions must be complied with to protect it:

- Clean the vehicle.
- Touch up the paint where necessary to prevent rust.
- Lubricate all the lubricators.
- Check whether any parts are worn or damaged and replace them, if necessary.
- Check the tires and inflate them to the recommended pressure.
- Drain the oil from the engine and replace it with new oil.
- Clean the fuel system and change the filter cartridges.
- Empty the fuel tank as usual and fill it with ten liters of special fuel for prolonged inactivity. Run the engine for ten minutes so the new solution can distribute evenly.
- Store any equipment.
- Use the battery isolation switch to deactivate the electrical circuit.
- Realign and lower all the mobile parts of the vehicle completely.
- Apply a layer of light grease on the uncovered rods of the hydraulic cylinders.
- Cover the exhaust opening.
- Close and lock all the windows.

- Close and lock the door.

## 17.3 - Restarting the vehicle

Preparing the vehicle after a long period of inactivity:

- Inflate the tires to the correct pressure.
- Remove the jack stands from under the axles.
- Fill the fuel tank.
- Check the radiator coolant level.
- Check the level of the various oils.
- Fit a fully charged battery.
- Remove the cover of the exhaust pipe.
- Remove the layer of grease on the exposed cylinder rods.
- Start the engine and check that all the controls work properly.
- Let the engine run for a few minutes.
- Verify the efficiency of the brake system.



- Waste material should not be dispersed in the environment but rather disposed of appropriately. Used lubricants, batteries, rags dirty with grease, brake pads etc. should be handed over to specialized companies authorized to dispose of polluting waste.
- Improper waste disposal poses a threat to the environment. The following are potentially dangerous waste: lubricants, fuel, cooling, filters and batteries.
- Do not spill or pour waste onto the ground, into the sewers or into water beds.
- Contact your local authority or collection centers for information for how to recycle or dispose of waste properly.

## 18.1 - Ecological considerations

A few helpful recommendations are listed below. Learn about current legislation in force in your country.

Ask suppliers for information about lubricating oils, fuels, antifreeze products, detergents, etc., about their effects on people and on the environment as well as on information regarding the regulations to be observed when using, stocking and disposing of such products.

- Do not refill the tanks using unsuitable jerry cans or pressurized combustible fueling systems as they may cause leaks and loss of significant amounts of liquid.
- Modern lubricating oils contain additives. Do not burn contaminated combustible oils and/or oils used in conventional heating systems.
- Take care not to spill used engine cooling fluids, engine and transmission lubricating oils, hydraulic oil, brake oil etc. while pouring or draining them. Store them safely and, when it is time, dispose of them in compliance with current legislation or with local facilities.
- Modern antifreeze liquids and their solutions, such as antifreeze and other additives should be replaced every two years. Make sure such liquids are not absorbed by the soil; they should be collected and disposed of appropriately.
- Do not intervene directly with the air conditioning systems (Optional), by opening them. These systems contain gas which must not be released into the atmosphere. Contact your dealer or an expert who has the necessary special equipment and who would, in any case, have to refill the system.
- Immediately repair any leaks or faults in the cooling or engine hydraulic systems.

## 18.2 - Protect the environment

It is illegal to pollute sewers, water sources or soil. Use only authorized dumping grounds centers, including the areas designated by the local authorities or workshops equipped with the necessary tools for the disposal of used oils. If in doubt, contact your local authority for relevant instructions.

To demolish the vehicle or the equipment, dismantle all components and keep the different types of materials separate for sending to the relative collection centers.

The following types of materials may be present:

- Ferrous materials (carpentries and mechanical components)
- Plastic materials (gaskets, belts, protections)
- Electric materials (cables, windings and similar)
- Oils and lubricants (hydraulic oil, reduction gear lubricants, lubricating greases)

## 20.1 - Components legend

Position	Description
1	Hydrostatic pump
2	Hydrostatic motor
3	Intake filter with clogging sensor
4	Tap
5	Variable displacement pump
6	Intake filter
7	Double pump
8	Flow divider
9	Vent
10	Valve
11	Inching valve
12	Brakes accumulator filling valve
13	Leveling control valve
14	Leveling cylinder
15	Fan hydraulic motor
16	Accumulator 50 Bars (725 psi)
17	Accumulators 50 Bars (725 psi)
18	Brake valve
19	Low pressure switch for brakes
20	Pressure switch for gear change
21	Power steering
22	Steering selection valve
23	Collector
24	Radiator
25	Return filter
26	Movements consent valve
27	Relief valve
28	Parking brake and gear change valve
29	Low pressure switch
30	3-way valve
31	Lowering movement control valve
32	Joystick servo drive
33	Hydraulic distributor
34	Lifting cylinder
35	Compensation cylinder
36	Tilting cylinder
37	Extension cylinder
38	Hydraulic sockets on boom head
39	Block valve
40	Hare pressure switch
41	Front axle
42	Rear axle

Position	Description
43	Negative brake

**20.2 - Diagram**

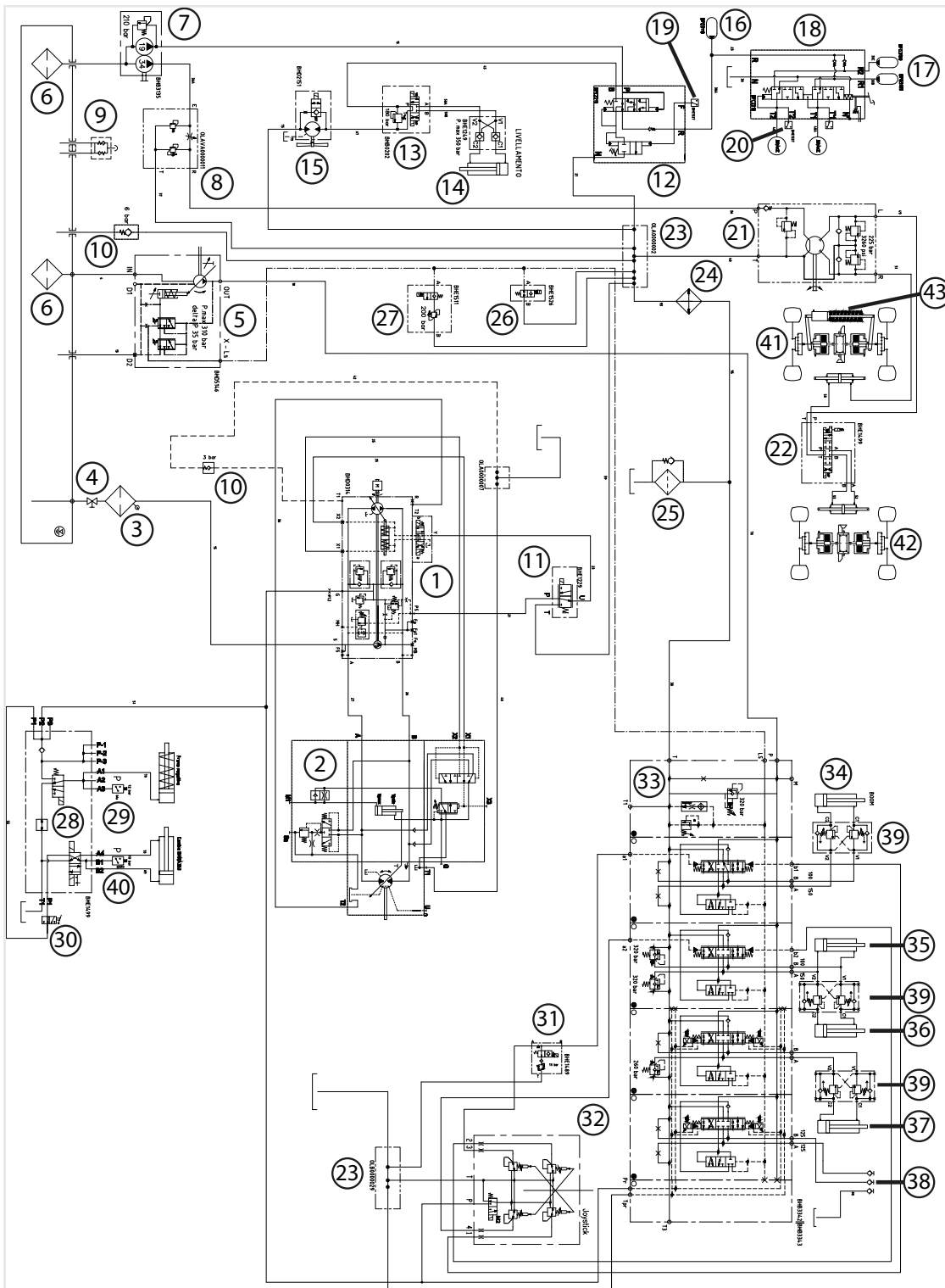

## 21.1 - Hercules 100.10 - 130.10

### 21.1.1 - Dimensions

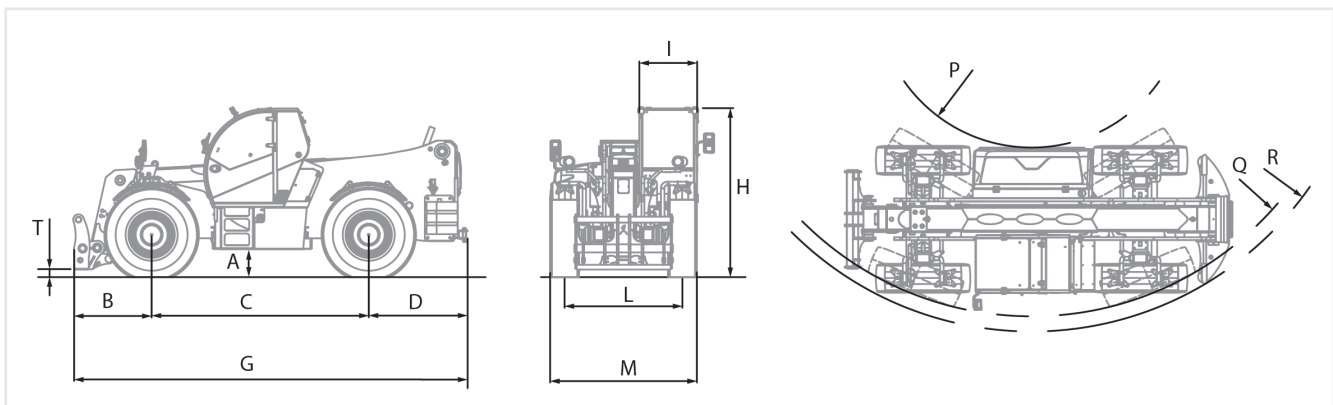

	MFR3203	MFS3204
Vehicle model	HERCULES 100.10	HERCULES 130.10
A	490 mm (19,3 in)	490 mm (19,3 in)
B	1270 mm (50 in)	1270 mm (50 in)
C	3300 mm (129,9 in)	3300 mm (129,9 in)
D	1480 mm (58,3 in)	1480 mm (58,3 in)
G	6050 mm (238,2 in)	6050 mm (238,2 in)
H	2890 mm (113,8 in)	2890 mm (113,8 in)
I	980 mm (38,6 in)	980 mm (38,6 in)
L	1975 mm (77,8 in)	1975 mm (77,8 in)
M	2420 mm (95,3 in)	2420 mm (95,3 in)
P	1070 mm (42,1 in)	1070 mm (42,1 in)
Q	3950 mm (155,5 in)	3950 mm (155,5 in)
R	4180 mm (164,6 in)	4180 mm (164,6 in)
T	134 mm (5,3 in)	134 mm (5,3 in)

**21.1.2 - Performance**

	<b>MFR3203</b>	<b>MFS3204</b>
Vehicle model	HERCULES 100.10	HERCULES 130.10
Fork swiveling angle	144°	144°
Pull-out force	9700 daN (21806 lbf)	9700 daN (21806 lbf)
Towing force	11000 daN (24729 lbf)	11000 daN (24729 lbf)
Maximum climb angle	36%	36%
Wheels maximum capacity	10000 kg (22046 lb)	13000 kg (28660 lb)
Maximum capacity	10000 kg (22046 lb)	13000 kg (28660 lb)
Capacity at maximum height on wheels	4900 kg (10803 lb)	7300 kg (16094 lb)
Capacity at maximum horizontal extension on wheels	2500 kg (5512 lb)	3500 kg (7716 lb)
Maximum horizontal extension on wheels	5,10 m (16,7 ft)	5,10 m (16,7 ft)
Maximum lifting height on wheels	9,50 m (31,2 ft)	9,50 m (31,2 ft)
Maximum horizontal extension	5,10 m (16,7 ft)	5,10 m (16,7 ft)
Forward swiveling	-	5 s
Reverse swiveling	-	10 s
Descent	-	13 s
Retraction	17 s	17 s
Extension	13 s	13 s
Lifting	-	19 s
Boom type	Telescopic with 1 telescopic section, counter-lever swing articulation (144°)	Telescopic with 1 telescopic section, counter-lever swing articulation (144°)
Max speed (referred to wheels with maximum permitted diameter)	34 km/h (21,1 mph)	34 km/h (21,1 mph)

**21.1.3 - Engine**

	<b>MFR3203</b>	<b>MFS3204</b>
Vehicle model	HERCULES 100.10	HERCULES 130.10
Brand	FPT	FPT
Model	NEF N45	NEF N45
Fueling	Diesel	Diesel
Displacement	4485 cm <sup>3</sup> (274 in <sup>3</sup> )	4485 cm <sup>3</sup> (274 in <sup>3</sup> )
Operation	4-stroke	4-stroke
Cooling system	Liquid	Liquid
Nominal power	125 kW (168 HP)	125 kW (168 HP)
@rpm	2200 rpm	2200 rpm
Peak power	128 kW (172 HP)	128 kW (172 HP)
@rpm	1900 rpm	1900 rpm
Number and arrangement of cylinders	4, Vertical in line	4, Vertical in line
Injection	Electronic, Common Rail	Electronic, Common Rail
Consumption	212 g/kWh (348,74 lb/Hp h)	212 g/kWh (348,74 lb/Hp h)

	MFR3203	MFS3204
@rpm	1900 rpm	1900 rpm
Maximum torque	710 Nm (524 lbft)	710 Nm (524 lbft)
@rpm	1500 rpm	1500 rpm
Intake	16-valve turbocharger with aftercooler	16-valve turbocharger with aftercooler
Emission standard	Stage V	Stage V
Exhaust gas treatment	(DOC + SCRoF)	(DOC + SCRoF)
Air Filter	Air pre-heating and air pre-filtering with dust separator	Air pre-heating and air pre-filtering with dust separator

### 21.1.3.1 - Emissions

	HERCULES 100.10 - MFMFR3203 HERCULES 130.10 - MFS3204
CO emissions	0.068 g/kWh (0.11 lb/Hp h)
HC emissions	0.012 g/kWh (0.02 lb/Hp h)
NOx emissions	0.390 g/kWh (0.64 lb/Hp h)
PM Particulate emissions	0.0024 g/kWh (0 lb/Hp h)

### 21.1.4 - Weights

	MFR3203	MFS3204
Vehicle model	HERCULES 100.10	HERCULES 130.10
Maximum mass	-	18000 kg (39683 lb)
Unladen weight	16000 kg (35274 lb)	18000 kg (39683 lb)
Maximum permitted mass on front axle	-	6000 kg (13228 lb)
Maximum permitted mass on rear axle	-	12000 kg (26455 lb)
Load per wheel	-	6395 daN (14377 lbf)

### 21.1.5 - Electrical and hydraulic system

	MFR3203	MFS3204
Vehicle model	HERCULES 100.10	HERCULES 130.10
Alternator	120 A	120 A
Battery	12 V - 184Ah - 1200 A	12 V - 184Ah - 1200 A
Starter motor	12 V - 3 kW	12 V - 3 kW
Hydraulic pump type	"Load Sensing" variable flow pump for boom movements. Gear pump for power steering drive and for the cooling fan	"Load Sensing" variable flow pump for boom movements. Gear pump for power steering drive and for the cooling fan
Hydraulic pump capacity	160 L/min (42,3 gal/min)	160 L/min (42,3 gal/min)
Max. operating pressure	31,0 MPa (4496 psi)	31,0 MPa (4496 psi)
Distributor type	"Flow Sharing" servo controlled hydraulic	"Flow Sharing" servo controlled hydraulic
Distributor control	Proportional 4in1 Joystick	Proportional 4in1 Joystick



	MFR3203	MFS3204
Boom hydraulic sockets	With Flat Face quick couplings with continuous oil function. Drain pipe for equipment.	With Flat Face quick couplings with continuous oil function. Drain pipe for equipment.

### 21.1.6 - Transmission

	MFR3203	MFS3204
Vehicle model	HERCULES 100.10	HERCULES 130.10
Transmission type	Hydrostatic with variable displacement pump	Hydrostatic with variable displacement pump
Reversal	Electro-Hydraulic	Electro-Hydraulic
Transmission gearbox	Servo-controlled 2-speed	Servo-controlled 2-speed
Inching	With electronic pedal for controlled forward movement	With electronic pedal for controlled forward movement

### 21.1.7 - Axles

	MFR3203	MFS3204
Vehicle model	HERCULES 100.10	HERCULES 130.10
Driving axles	Front and rear	Front and rear
Type of axles	2 steering, with 4 epicycloidal reduction gears	2 steering, with 4 epicycloidal reduction gears
Service braking	Oil bath with servo brake on front and rear axle with double hydraulic system	Oil bath with servo brake on front and rear axle with double hydraulic system
Parking braking	Negative actuation with electrical control	Negative actuation with electrical control
Front axle	With transverse leveling device (8° + 8°) with control in the cab and 45% self-locking differential	With transverse leveling device (8° + 8°) with control in the cab and 45% self-locking differential
Rear axle	Swinging	Swinging
Type of steering	4 wheels / transversal / 2 wheels	4 wheels / transversal / 2 wheels

### 21.1.8 - Acoustic pressure

	MFR3203	MFS3204
Vehicle model	HERCULES 100.10	HERCULES 130.10
Acoustic pressure: Reference standard for stopped and running vehicle	Directive 2009/63/EC	Directive 2009/63/EC
Acoustic pressure: Value with stopped vehicle	74,3 dB(A)	74,3 dB(A)
Acoustic pressure: Value with running vehicle	83,7 dB(A)	83,7 dB(A)
Acoustic pressure: Reference standard perceived by the operator	UNI EN 12053:2008	UNI EN 12053:2008
Acoustic pressure: Value perceived by the operator with closed cab	70,9 dB(A)	70,9 dB(A)

### 21.1.9 - Acoustic power

	MFR3203	MFS3204
Vehicle model	HERCULES 100.10	HERCULES 130.10
Acoustic power: Reference standard	Directive 2000/14/EC	Directive 2000/14/EC
Acoustic power: Guaranteed value	108 dB(A)	108 dB(A)
Acoustic power: Measured value	107 dB(A)	107 dB(A)

### 21.1.10 - Vibration

	MFR3203	MFS3204
Vehicle model	HERCULES 100.10	HERCULES 130.10
Reference standard for seat vibrations	UNI EN 13059:2008	UNI EN 13059:2008
Value for seat vibrations	0,81 m/s <sup>2</sup> (2,7 ft/s <sup>2</sup> )	0,81 m/s <sup>2</sup> (2,7 ft/s <sup>2</sup> )
Uncertainty for seat vibrations value	0,24 m/s <sup>2</sup> (0,8 ft/s <sup>2</sup> )	0,24 m/s <sup>2</sup> (0,8 ft/s <sup>2</sup> )
Reference standard for steering wheel vibrations	UNI EN 1032:2009	UNI EN 1032:2009
Value for steering wheel vibrations	2,91 m/s <sup>2</sup> (9,5 ft/s <sup>2</sup> )	2,91 m/s <sup>2</sup> (9,5 ft/s <sup>2</sup> )
Uncertainty for steering wheel vibrations value	0,87 m/s <sup>2</sup> (2,9 ft/s <sup>2</sup> )	0,87 m/s <sup>2</sup> (2,9 ft/s <sup>2</sup> )

### 21.1.11 - Filling

	MFR3203	MFS3204
Vehicle model	HERCULES 100.10	HERCULES 130.10
Engine oil specifications	SAE 10W-30/SAE15W-40 (<25°C) SAE 10W-30/SAE15W-40 (<-10° TO <25°)	SAE 10W-30/SAE15W-40 (<25°C) SAE 10W-30/SAE15W-40 (<-10° TO <25°)
Engine oil quantity	8,7 L (2,3 gal)	8,7 L (2,3 gal)
Front axle oil specifications	DIECI GEAR EP/E LS 85W-90 API GL-5, MIL-L-2105D; (< -20°C / < -4°F) DIECI SPECIAL LS SYNT AXEL OIL 75W-90	DIECI GEAR EP/E LS 85W-90 API GL-5, MIL-L-2105D; (< -20°C / < -4°F) DIECI SPECIAL LS SYNT AXEL OIL 75W-90
Front axle oil quantity	9,00 L (2,38 gal)	9,00 L (2,38 gal)
Front reduction gears oil quantity	1,25 L (0,33 gal)	1,25 L (0,33 gal)
Rear axle oil specifications	DIECI GEAR EP/E LS 85W-90 API GL-5, MIL-L-2105D; (< -20°C / < -4°F) DIECI SPECIAL LS SYNT AXEL OIL 75W-90	DIECI GEAR EP/E LS 85W-90 API GL-5, MIL-L-2105D; (< -20°C / < -4°F) DIECI SPECIAL LS SYNT AXEL OIL 75W-90
Rear axle oil quantity	9,00 L (2,38 gal)	9,00 L (2,38 gal)
Rear reduction gears oil quantity	1,25 L (0,33 gal)	1,25 L (0,33 gal)
Transmission gearbox oil specifications	(from -10°C/14°F to +35°C/95°F) DIECI UTTO FLUID WB SAE 10W/30; (from -30°C/-22°F to +10°C/14°F) DIECI MTF III FLUID	(from -10°C/14°F to +35°C/95°F) DIECI UTTO FLUID WB SAE 10W/30; (from -30°C/-22°F to +10°C/14°F) DIECI MTF III FLUID
Transmission gearbox oil quantity	1,80 L (0,48 gal)	1,80 L (0,48 gal)
Air conditioning refrigerant specifications	R134A	R134A
Air conditioning refrigerant quantity	1,10 kg (2 lb)	1,10 kg (2 lb)
Hydraulic oil type	DIECI Hydro Telehandler Fluid ISO46	DIECI Hydro Telehandler Fluid ISO46
Hydraulic system (total)	246,0 L (64,99 gal)	298,0 L (78,72 gal)

	MFR3203	MFS3204
Adblue tank	34,0 L (8,98 gal)	34,0 L (8,98 gal)
Fuel tank	207,0 L (54,68 gal)	207,0 L (54,68 gal)
Coolant quantity	15,00 L (3,96 gal)	15,00 L (3,96 gal)
Coolant specifications	Antifreeze, Red	Antifreeze, Red

### 21.1.11.1 - DIECI Hydro Telehandler Fluid ISO46

The sticker shown aside (170350-1) indicates that the hydraulic circuit is filled with hydraulic oil DIECI Hydro Telehandler Fluid ISO46.



170350-1

#### Specifications:

ISO 6743-4 HV, Afnor NFE 48-602, ISO 11158, DIN 51524 Part 3 HVLP, Afnor NFE 48-603 HV, ASTM D6158, Denison HF-0 / HF-1 / HF-2, Eaton Vickers I-286-S / M-2950-S, Cincinnati Vehicle P-68 / P-69 / P-70, Afnor NFE 48-690(dry), Afnor NFE 48-691(wet), U.S. Steel 126 / 127 / 136, JCMAS HK, Bosch variable vane pumps, Rexroth RE 90220, Sauer Danfoss 520L0463, General Motors (LS-2) LH-03-1 / LH-04-1 / LH-06-1, SEB 181222.

#### Chemical-physical characteristics

Properties	Analysis method	Unit of measure	Value
Density at 15°C	ASTM D1298	kg/l	0.88
Viscosity at 40°C	ASTM D445	cSt	46.6
Viscosity at 100°C	ASTM D445	cSt	8.6
Viscosity Index	ASTM D2270	-	165
Kinematic viscosity at 40°C after Sonic Shear	ASTM D445	cSt	41.6
Viscosity Index after Sonic Shear	ASTM D2270	-	144
FZG Failure Load Stage	ASTM D5182	Stage	12
Flash Point (C.O.C.)	ASTM D92	°C	210
Pour point	ASTM D97	°C	-35
Temperature for Brookfield viscosity of 750cP	ASTM D2983	°C	-9

21.1.11.2 - DIECI Hydro Telehandler Fluid ISO32



**NOTE**

**Hydraulic oil for cold climates is an optional.**

Consult your dealer in case of doubts or information on your vehicle.

The sticker shown aside (170351-1) indicates that the hydraulic circuit is filled with hydraulic oil DIECI Hydro Telehandler Fluid ISO32.



170351-1

**Specifications:**

ISO 6743-4 HV, Afnor NFE 48-602, ISO 11158, DIN 51524 Part 3 HVLP, Afnor NFE 48-603 HV, ASTM D6158, Denison HF-0 / HF-1 / HF-2, Eaton Vickers I-286-S / M-2950-S, Cincinnati Vehicle P-68 / P-69 / P-70, Afnor NFE 48-690(dry), Afnor NFE 48-691(wet), U.S. Steel 126 / 127 / 136, JCMAS HK, Bosch variable vane pumps, Rexroth RE 90220, Sauer Danfoss 520L0463, General Motors (LS-2) LH-03-1 / LH-04-1 / LH-06-1, SEB 181222

**Chemical-physical characteristics:**

Properties	Analysis method	Unit of measure	Value
Color	-	-	Green-Blue
Density at 15°C	ASTM D1298	kg/l	0.878
Viscosity at 40°C	ASTM D445	cSt	32.4
Viscosity at 100°C	ASTM D445	cSt	6.6
Viscosity Index	ASTM D2270	-	165
Flash Point (C.O.C.)	ASTM D92	°C	205
Pour point	ASTM D97	°C	-37

21.1.11.3 - Declaration of conformity for F-Gas

In accordance with Art. 12 of EU Reg.No. 517/2014 concerning the fluorinated gases contained in the air-conditioning system, on the vehicles there are:

- Label indicating the amount of fluorinated gases present (Fig. 170501).
- Declaration of Conformity (a facsimile is shown below)

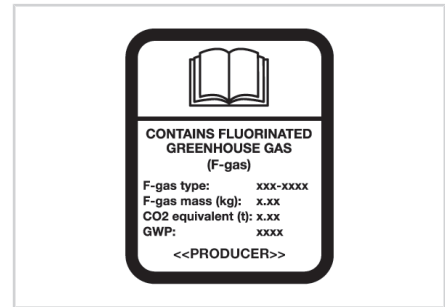

170501-1

**(Declaration of conformity with article 14 of Regulation (EU) No. 517/2014 of the European Parliament and of the Council)**

We Dieci s.r.l. (VAT number 01682740350), declare under our sole responsibility that when placing on the market pre-charged equipment, which we import to or manufacture in the Union, the hydrofluorocarbons contained in that equipment are accounted for within the quota system referred to in Chapter IV of Regulation (EU) No 517/2014 of the European Parliament and of the Council as:

*[please tick the relevant option(s); coverage by the quota system is achieved by one or more of the options below]*

- A. we hold authorisation(s) issued in accordance with Article 18(2) of Regulation (EU) No 517/2014 and registered in the registry referred to in Article 17 of that Regulation, at the time of release for free circulation to use the quota of a producer or importer of hydrofluorocarbons subject to Article 15 of Regulation (EU) No 517/2014 that cover(s) the quantity of hydrofluorocarbons contained in the equipment.
- B. *[for importers of equipment only]* the hydrofluorocarbons contained in the equipment have been placed on the market in the Union, subsequently exported and charged into the equipment outside the Union, and the undertaking that placed the hydrofluorocarbons on the market made a declaration stating that the quantity of hydrofluorocarbons has been or will be reported as placed on the market in the Union and that it has not been and will not be reported as direct supply for export in the meaning of Article 15(2)(c) of Regulation (EU) No 517/2014 pursuant to Article 19 of Regulation (EU) No 517/2014 and Section 5C of the Annex to Commission Implementing Regulation (EU) No 1191/2014.
- C. *[for equipment manufactured in the Union only]* the hydrofluorocarbons charged into the equipment were placed on the market by a producer or importer of hydrofluorocarbons subject to Article 15 of Regulation (EU) No 517/2014.

Signed for and on behalf of: Ennio Manghi, Director at DIECI S.r.l.

Montecchio Emilia, 31.01.2017

DIECI SRL  
Via E. Majorana, 2-4  
Montecchio Emilia (RE)  
One of the Directors  
Ennio Manghi

**Dieci Srl**  
Via E. Majorana, 2-4 • 42027 Montecchio Emilia • (Reggio Emilia) ITALY  
Tel. ++39 0522 869611 - Fax ++39 0522 869798 (Reception) - Fax ++39 0522 869797 (Amm.ne)  
[www.dieci.com](http://www.dieci.com) • E-mail: [info@dieci.com](mailto:info@dieci.com)  
Cap. Soc. Int. Vers. € 10.000.000,00 Reg. Impr. R.E. N. 01283560686 R.E.A. R.E. N. 204278 - C.F. 01283560686 • P.I. 01682740350

21.1.12 - Tires data



**ATTENTION**

**Take precautions before operating on the tires pressure.**

Refer to the chapter Tires [▶ 186].



**Hercules**

DOCDI0001495



AID4986	Michelin	17,5 R25	Xmine D2	-	5,0	73
AID4984	Camso	17,5 R25	-	-	7,0	102

	Standard tires	Optional tires
MFS3204	17.5x25"	17.5R25"
MFR3203	17.5x25"	17.5R25"

**See also**

 Tires [▶ 186]

### 21.1.13 - Equipment

	Production code	Description
TCV0063	BCV8286	Fork spreader/translator complete with pair of forks 200 x 70 L = 1200 mm. Capacity 13.0 t (COG 0.6 m). Fork width from 790 to 2110 mm. (electrical contact on boom head is compulsory)
TCV0064	BCV8287	Fork extender/translator complete with pair of forks 200 x 70 L = 1800 mm. Capacity 13.0 t (COG 0.6 m). Fork width from 790 to 2110 mm. (electrical contact on boom head is compulsory)
TCV0065	BCV8358	Fork spreader/translator complete with pair of forks 200 x 80 L = 2400 mm. Capacity 11.0 t (COG 0.6 m). Fork width from 970 to 2310 mm. (electrical contact on boom head is compulsory)
TFR0051	BUD1271	Floating forks mm 200 x 70 L = 1200. Capacity 13.0 t (COG 0.6 m).
TFR0052	BUD1085	Floating forks mm 200 x 70 L = 1800. Capacity 13.0 t (COG 0.6 m).
TFR0053	BUD1091	Floating forks mm 200 x 80 L = 2400. Capacity 13.0 t (COG 0.6 m).
TFR0054	BUD1278	Pair of fork extensions L = 1900 mm for forks mm 200x70x1200
TFR0056	AAAAAAA	Fork counterplate guard
TGN0116	BUD4074	Gripper for pipe with pipe locker diameter up to 900 mm. Forks L = 1800 mm. Capacity 6.0 t (COG 0.9 m) (Electrical contact on boom head is compulsory)
TGN0117	BUD4098	Gripper for pipe with pipe locker diameter up to 900 mm. Forks L = 2400 mm. Capacity 5.0 t (COG 1.2 m) (Electrical contact on boom head is compulsory)
TGN0118	BUD4564	Gripper for tires D.3500 capacity 4.0 t (Pre-arrangement for 4 movements special equipment is compulsory)
TBN0335	BUB2793	Bucket for generic use without teeth, 3.00 m <sup>3</sup> SAE heap (width 2.50 m)(Recommended bucket with blade protector)
TBN0336	BUB2793-S	Bucket for generic use without teeth, 3.00 m <sup>3</sup> SAE heap (width 2.50 m) with BLADE PROTECTOR
TBN0337	BUB2794	Bucket for generic use with teeth, 3.00 m <sup>3</sup> SAE heap (width 2.50 m)
TBN0338	BUB2529	Bucket for light materials (maximum specific weight 0.8 t/m <sup>3</sup> ) 4.50 m <sup>3</sup> SAE heap (width 3.00 m) (Recommended bucket with blade protector).
TBN0339	BUB2529-S	Bucket for light materials (maximum specific weight 0.8 t/m <sup>3</sup> ) 4.50 m <sup>3</sup> SAE heap (width 3.00 m) WITH BLADE PROTECTOR.
TCS0171	BUD6576	Front man basket cm 215 x 120. Capacity 1000 kg incl. 3 people. (Proportional hydraulic distributors with pre-arrangement for basket and equipment recognition system is compulsory)
TCS0172	BUD6577	Front man basket cm 215 x 120. Capacity 1000 kg incl. 3 people. For vehicle with remote control. (Proportional hydraulic distributors with pre-arrangement for basket and equipment recognition system is compulsory)
TCS0173	BUD6578	Trilateral passenger basket cm 120 x 240 with hydraulic extension up to cm 440. Capacity 300 kg incl. 3 people (Proportional hydraulic distributors with pre-arrangement for basket and equipment recognition system is compulsory)
TCS0174	BUD6579	Trilateral passenger basket cm 120 x 240 with hydraulic extension up to cm 440. Capacity 300 kg incl. 3 people. For vehicle with remote control (Proportional hydraulic distributors with pre-arrangement for basket and equipment recognition system is compulsory)



	Production code	Description
TCS0175	BUD6352	Material basket 200 x 120 x 130 cm with side door. Capacity 1500 kg
TSL0125	BUD4629	Jib L = 2.7 m with hitch (capacity 4.0 t) (Equipment recognition system is compulsory)
TSL0126	BUB2516	Hook for fork carriage with the same capacity as the vehicle
TSL0127	BUD4630	Winch for fork carriage (capacity 8.0 t) with double tow rope guide (Equipment recognition system is compulsory)

### 21.1.14 - Equipment

	Production code	Description
TCV0063	BCV8286	Fork spreader/translator complete with pair of forks 200 x 70 L = 1200 mm. Capacity 13.0 t (COG 0.6 m). Fork width from 790 to 2110 mm. (electrical contact on boom head is compulsory)
TCV0064	BCV8287	Fork extender/translator complete with pair of forks 200 x 70 L = 1800 mm. Capacity 13.0 t (COG 0.6 m). Fork width from 790 to 2110 mm. (electrical contact on boom head is compulsory)
TCV0065	BCV8358	Fork spreader/translator complete with pair of forks 200 x 80 L = 2400 mm. Capacity 11.0 t (COG 0.6 m). Fork width from 970 to 2310 mm. (electrical contact on boom head is compulsory)
TFR0051	BUD1271	Floating forks mm 200 x 70 L = 1200. Capacity 13.0 t (COG 0.6 m).
TFR0052	BUD1085	Floating forks mm 200 x 70 L = 1800. Capacity 13.0 t (COG 0.6 m).
TFR0053	BUD1091	Floating forks mm 200 x 80 L = 2400. Capacity 13.0 t (COG 0.6 m).
TFR0054	BUD1278	Pair of fork extensions L = 1900 mm for forks mm 200x70x1200
TFR0056	AAAAAAA	Fork counterplate guard
TGN0116	BUD4074	Gripper for pipe with pipe locker diameter up to 900 mm. Forks L = 1800 mm. Capacity 6.0 t (COG 0.9 m) (Electrical contact on boom head is compulsory)
TGN0117	BUD4098	Gripper for pipe with pipe locker diameter up to 900 mm. Forks L = 2400 mm. Capacity 5.0 t (COG 1.2 m) (Electrical contact on boom head is compulsory)
TGN0118	BUD4564	Gripper for tires D.3500 capacity 4.0 t (Pre-arrangement for 4 movements special equipment is compulsory)
TBN0335	BUB2793	Bucket for generic use without teeth, 3.00 m <sup>3</sup> SAE heap (width 2.50 m)(Recommended bucket with blade protector)
TBN0336	BUB2793-S	Bucket for generic use without teeth, 3.00 m <sup>3</sup> SAE heap (width 2.50 m) with BLADE PROTECTOR
TBN0337	BUB2794	Bucket for generic use with teeth, 3.00 m <sup>3</sup> SAE heap (width 2.50 m)
TBN0338	BUB2529	Bucket for light materials (maximum specific weight 0.8 t/m <sup>3</sup> ) 4.50 m <sup>3</sup> SAE heap (width 3.00 m) (Recommended bucket with blade protector).
TBN0339	BUB2529-S	Bucket for light materials (maximum specific weight 0.8 t/m <sup>3</sup> ) 4.50 m <sup>3</sup> SAE heap (width 3.00 m) WITH BLADE PROTECTOR.
TCS0171	BUD6576	Front man basket cm 215 x 120. Capacity 1000 kg incl. 3 people. (Proportional hydraulic distributors with pre-arrangement for basket and equipment recognition system is compulsory)
TCS0172	BUD6577	Front man basket cm 215 x 120. Capacity 1000 kg incl. 3 people. For vehicle with remote control. (Proportional hydraulic distributors with pre-arrangement for basket and equipment recognition system is compulsory)
TCS0173	BUD6578	Trilateral passenger basket cm 120 x 240 with hydraulic extension up to cm 440. Capacity 300 kg incl. 3 people (Proportional hydraulic distributors with pre-arrangement for basket and equipment recognition system is compulsory)
TCS0174	BUD6579	Trilateral passenger basket cm 120 x 240 with hydraulic extension up to cm 440. Capacity 300 kg incl. 3 people. For vehicle with remote control (Proportional hydraulic distributors with pre-arrangement for basket and equipment recognition system is compulsory)

	Production code	Description
TCS0175	BUD6352	Material basket 200 x 120 x 130 cm with side door. Capacity 1500 kg
TSL0125	BUD4629	Jib L = 2.7 m with hitch (capacity 4.0 t) (Equipment recognition system is compulsory)
TSL0126	BUB2516	Hook for fork carriage with the same capacity as the vehicle
TSL0127	BUD4630	Winch for fork carriage (capacity 8.0 t) with double tow rope guide (Equipment recognition system is compulsory)

## 21.2 - Environmental conditions

Although the vehicle and the equipment can be used in several different situations, however, it is necessary to observe, as a precautionary measure, compliance with minimum standards of operation as specified below:

Parameter	Allowed values
Operating temperatures	from -20°C to +40 °C (from -4 °F to 104 °F)
Average daily temperature	< +40 °C (< 104 °F)
Storage temperature	from -25 °C to +50 °C (from -13 °F to 122 °F)
Humidity	from 20 % to 95 %
Altitude	< 2500 m (< 8200 ft)

Table 5: Environmental conditions table

## 21.3 - Electromagnetic Interference

In the case of additional equipment installed by the customer, the user must verify if the installation causes interference of any kind with the tools of the vehicle; if so, the user must correct such interferences.

It is essential to pay particular attention to mobile devices such as radio communications (telephones) that must be installed by trained service technicians must use externally mounted antennas.

In general, it should be kept in mind that any additional electrical equipment installed must comply with the regulations in the country of use of the vehicle.

## 21.4 - Radiations

The vehicle, in conditions of normal use, does not produce any type of radiation, ionizing and non ionizing, that can cause problems to the operator.

**21.5 - Forks technical data**

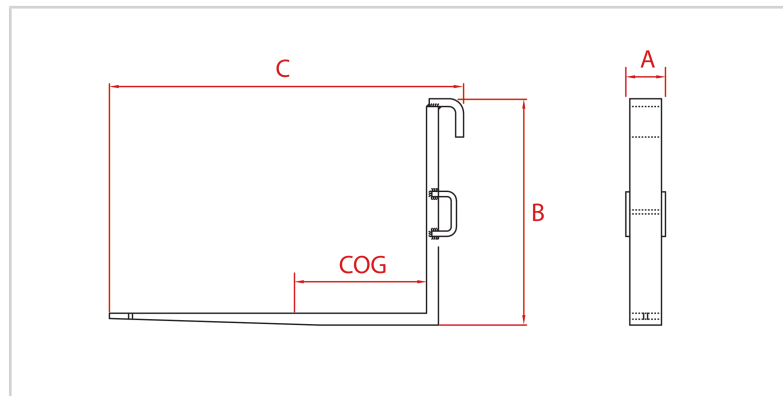

170221-1: Forks dimensions

**NOTE!** The dimensions indicated are for only one fork.

	<b>BUD1091</b>
Price list equipment code	TFR0023;TFR0053
Capacity	16000 kg (35274 lb)
Weight	444 kg (979 lb)
Width (A)	200 mm (7,9 in)
Height (B)	1130 mm (44,5 in)
Length (C)	2634 mm (103,7 in)
COG	600 mm (23,6 in)
Width section	200 mm (7,9 in)
Height section	80 mm (3,1 in)
	<b>BUD1085</b>
Price list equipment code	TFR0022;TFR0052
Capacity	13000 kg (28660 lb)
Weight	320 kg (705 lb)
Width (A)	200 mm (7,9 in)
Height (B)	1100 mm (43,3 in)
Length (C)	2024 mm (79,7 in)
COG	600 mm (23,6 in)
Width section	200 mm (7,9 in)
Height section	70 mm (2,8 in)
	<b>BUD1271</b>
Price list equipment code	TFR0051
Capacity	13000 kg (28660 lb)
Weight	257 kg (567 lb)
Width (A)	200 mm (7,9 in)
Height (B)	1100 mm (43,3 in)
Length (C)	1424 mm (56,1 in)
COG	600 mm (23,6 in)
Width section	200 mm (7,9 in)
Height section	70 mm (2,8 in)

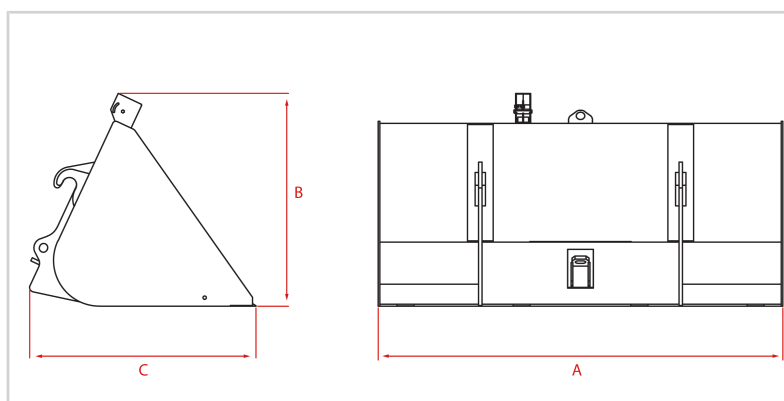
**21.6 - Buckets technical data**

170220-1: Buckets dimensions

	<b>BUB2529</b>
Price list equipment code	TBN0094;TBN0338
SAE heap capacity	4,5 m <sup>3</sup> (159 ft <sup>3</sup> )
Weight	1355 kg (2987 lb)
Width (A)	3000 mm (118,1 in)
Height (B)	1451 mm (57,1 in)
Length (C)	1888 mm (74,3 in)
	<b>BUB2793</b>
Price list equipment code	TBN0091;TBN0335
SAE heap capacity	3 m <sup>3</sup> (106 ft <sup>3</sup> )
Weight	1728 kg (3810 lb)
Width (A)	2500 mm (98,4 in)
Height (B)	1335 mm (52,6 in)
Length (C)	1713 mm (67,4 in)





## Operating modes key

Codes have been used in the tables that indicate the vehicle and equipment combination in order to indicate the various operating modes on the vehicle.

Operating mode	Icons		Description
DIAG_M100		-	Only on wheels
DIAG_M200		-	Front outriggers (2) on wheels
DIAG_M201		-	Front outriggers (2), on feet
DIAG_M300			Flap down outriggers (4), on wheels with front turret (0°)
DIAG_M301			Flap down outriggers (4), on wheels with rotated turret (400°)
DIAG_M302			Flap down outriggers (4), on feet with rotated turret (400°)
DIAG_M400			Crossbeam outriggers (4), on wheels with front turret (0°)
DIAG_M401			Crossbeam outriggers (4), on wheels with rotated turret (0°)
DIAG_M402			Crossbeam outriggers (4), on 100% extended feet and turret in rotation (360°)
DIAG_M403			Crossbeam outriggers (4), on 50% extended feet and turret in rotation (360°)
DIAG_M404			Crossbeam outriggers (4), on 0% extended feet and turret in rotation (360°)
DIAG_M500			Flap down outriggers (4), on wheels with front turret (0°)
DIAG_M501			Flap down outriggers (4), on wheels with rotated turret (360°)
DIAG_M502			Flap down outriggers (4), on feet with front turret (0°)



Operating mode	Icons	Description
DIAG_M503	 	Flap down outriggers (4), on feet with rotated turret (360°)

**How to read the equipment matching tables**

The vehicle and equipment combinations are shown in the following tables and include the following cases:

Indication	Description
x	Load chart not necessary for vehicle and equipment use in the specified operating mode.
NO	It is not possible to use vehicle and equipment in the specified operating mode.
AXB0000 or DOCDI0000000	Load chart code of the vehicle and equipment in a specific operating mode.
N/D	Load chart not available.

## 22.1 - Load charts Hercules 100.10

Diagrams code	Vehicle code	Vehicle model	Production equipment code	Price list equipment code	Unit of measure	Operating Mode		
AXB1537	MFR3203	Hercules 100.10	BUD1271;	TFR0051;	Metric	DIAG_100		
AXB1537-105A			BUD1085;	TFR0052;				
AXB1537-125A			BUD1091	TFR0053				
DOCDI0001166			BUD1271	TFR0051	Imperial			
AXB1537-106A			BUD1085	TFR0052				
AXB1537-107A			BUD1091	TFR0053				
DOCDI0001567			BCV8286	TCV0063	Metric			
DOCDI0001568			BCV8287	TCV0064				
DOCDI0001569			BCV8358	TCV0065				
DOCDI0001570			BCV8286;	TCV0063;	Imperial			
			BCV8287;	TCV0064;				
			BCV8358	TCV0065				
					BCV8287;		TCV0064;	Imperial
					BCV8358		TCV0065	

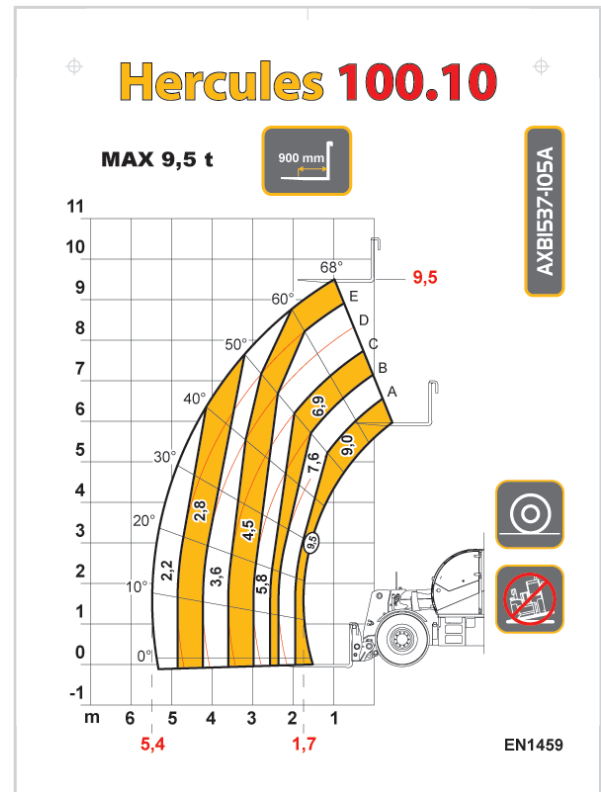
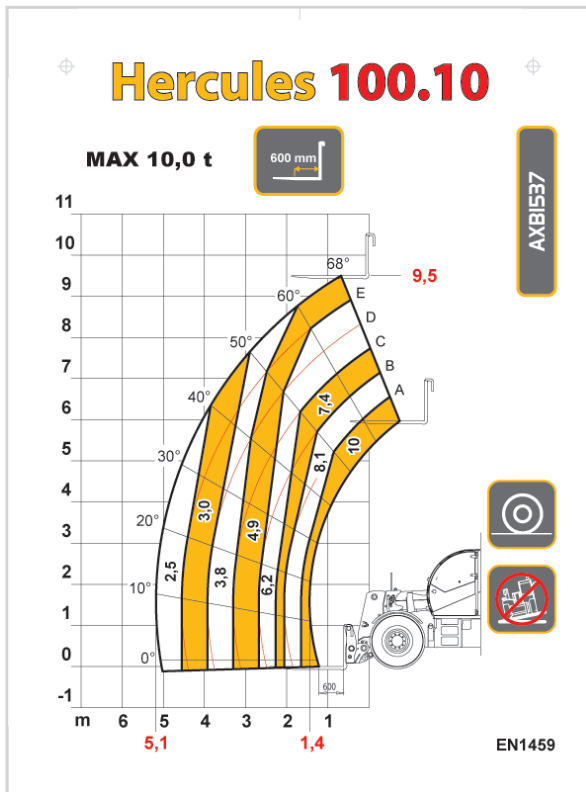

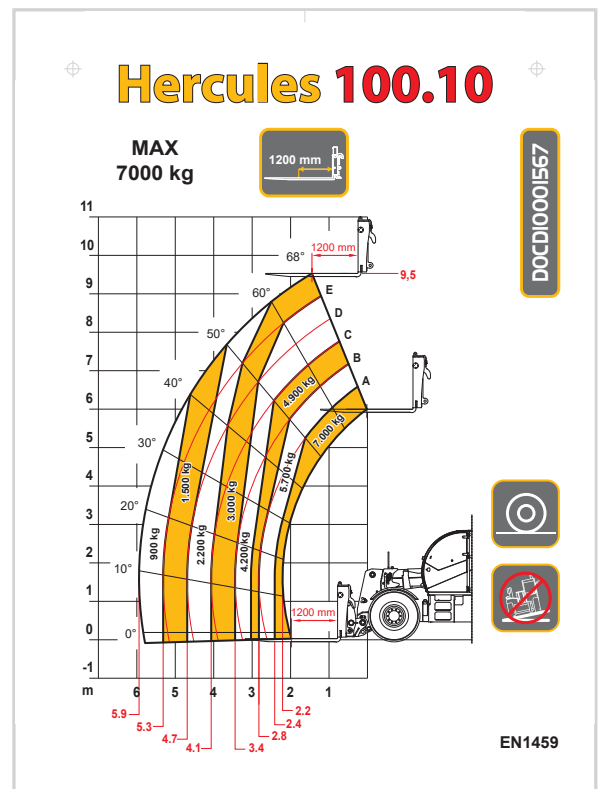
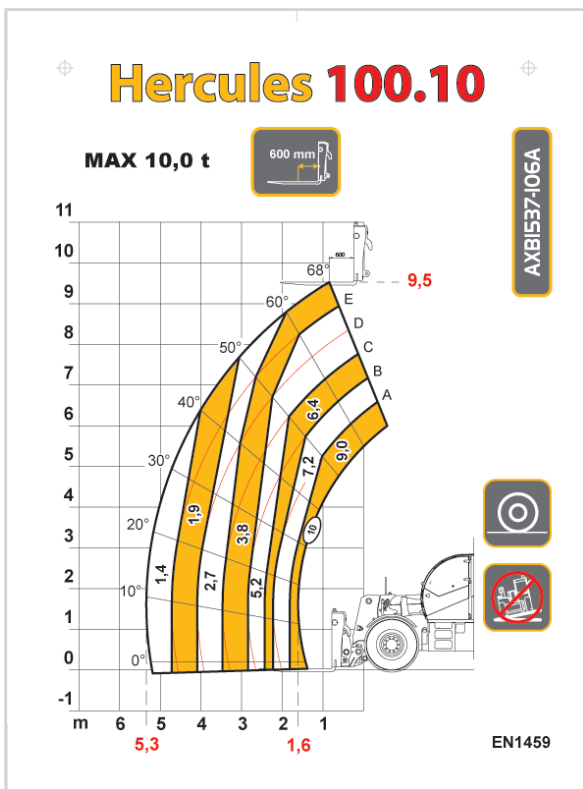
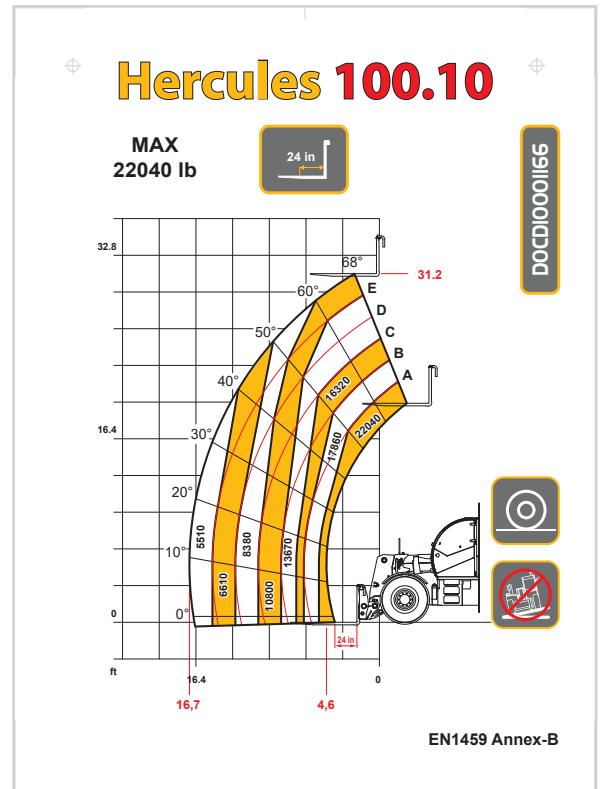
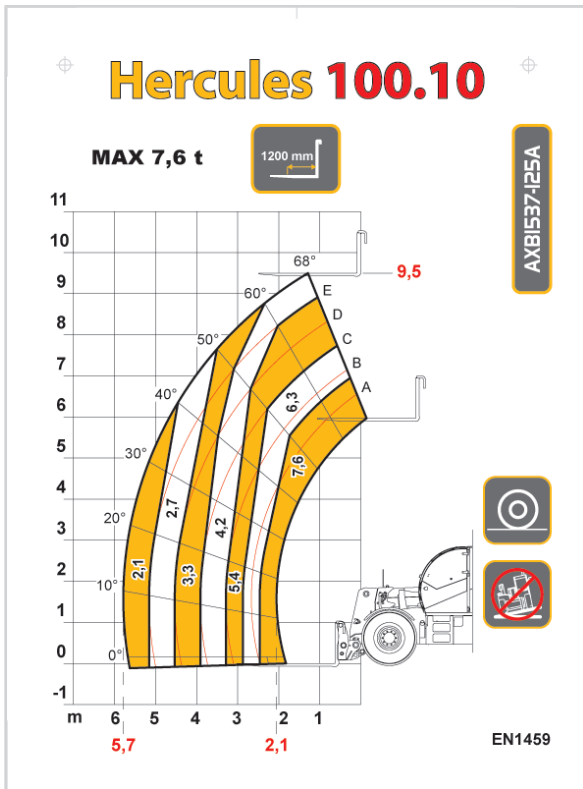

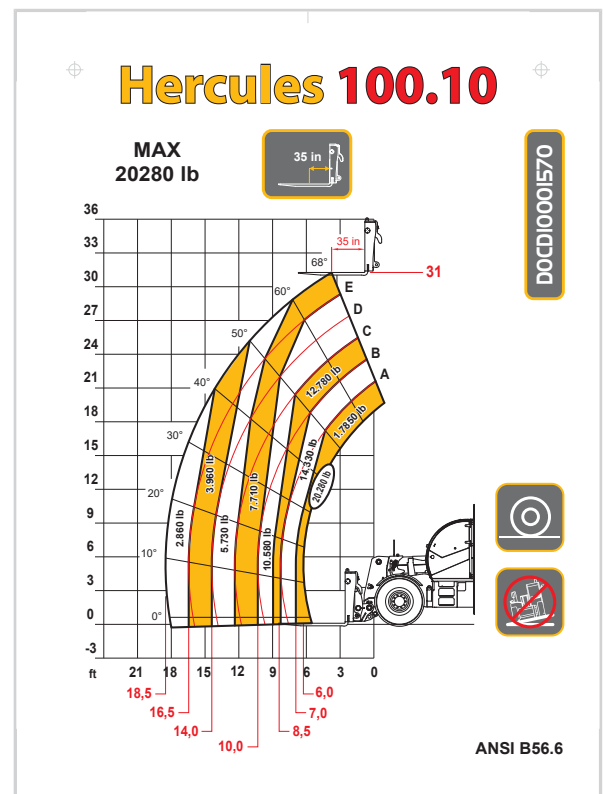
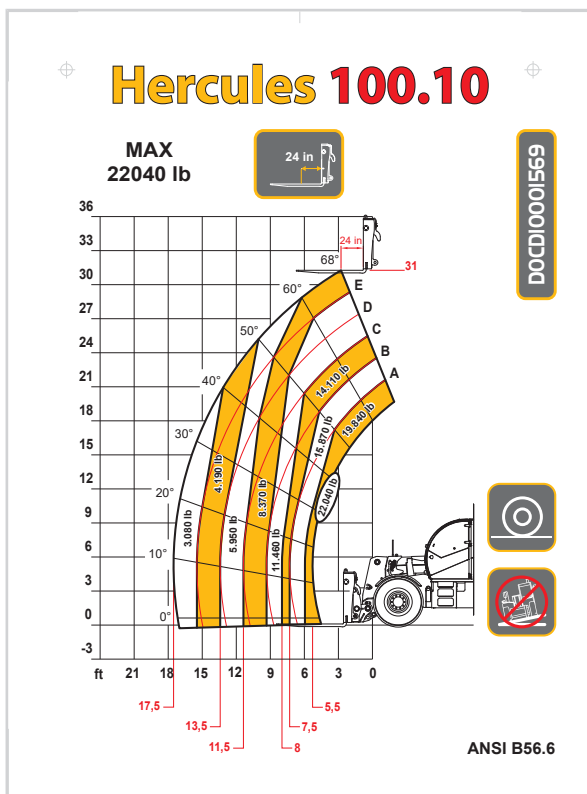
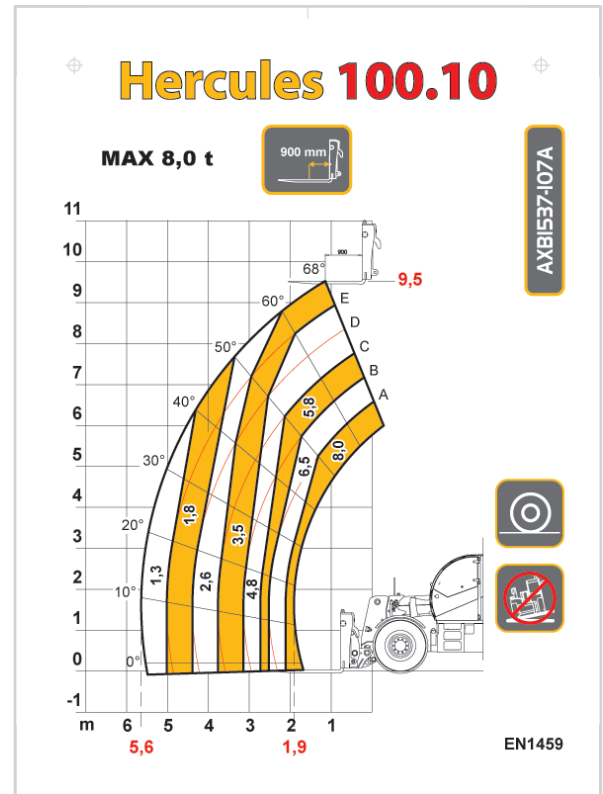
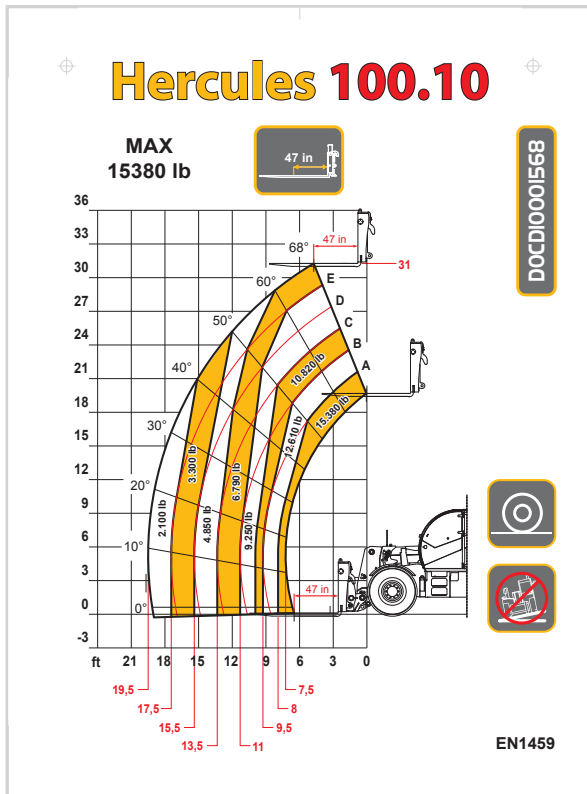

**22.2 - Load charts Hercules 130.10**

Diagrams code	Vehicle code	Vehicle model	Production equipment code	Price list equipment code	Unit of measure	Operating Mode
DOCDI0001354	MFS3204	Hercules 130.10	BUD1271	TFR0051	Metric	DIAG_100
			BUD1085	TFR0052		
			BUD1091	TFR0053		
DOCDI0001458			BUD1271	TFR0051	Imperial	
			BUD1085	TFR0052		
			BUD1091	TFR0053		
DOCDI0001554			BCV8286	TCV0063	Metric	
			BCV8287	TCV0064		
			BCV8358	TCV0065		
DOCDI0001555			BCV8287	TCV0064		
			BCV8358	TCV0065		
DOCDI0001556			BCV8358	TCV0065		

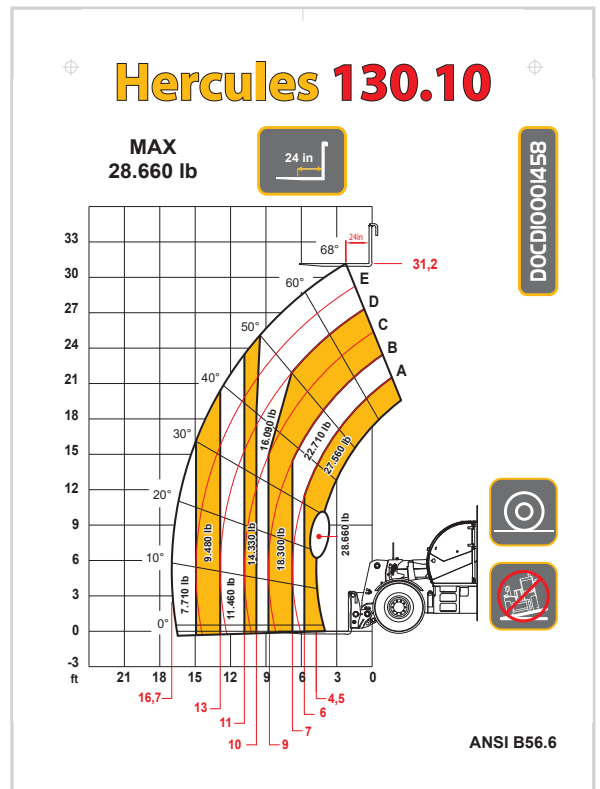
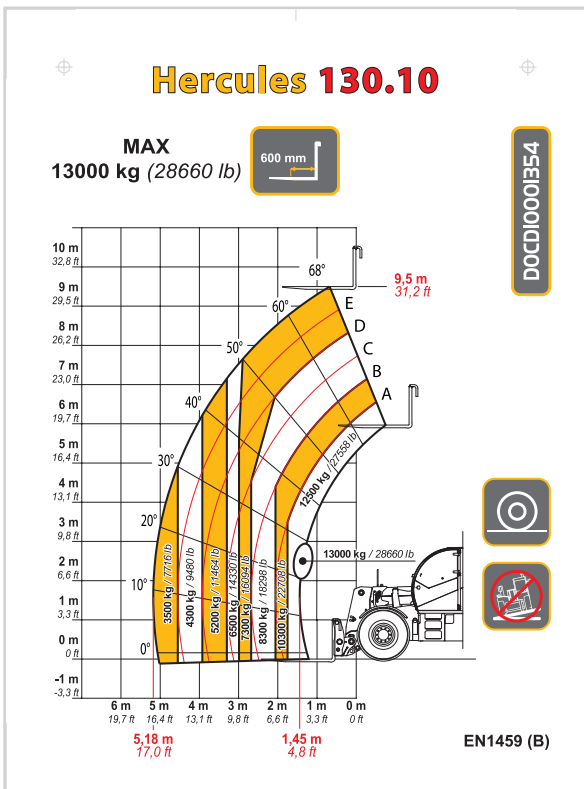

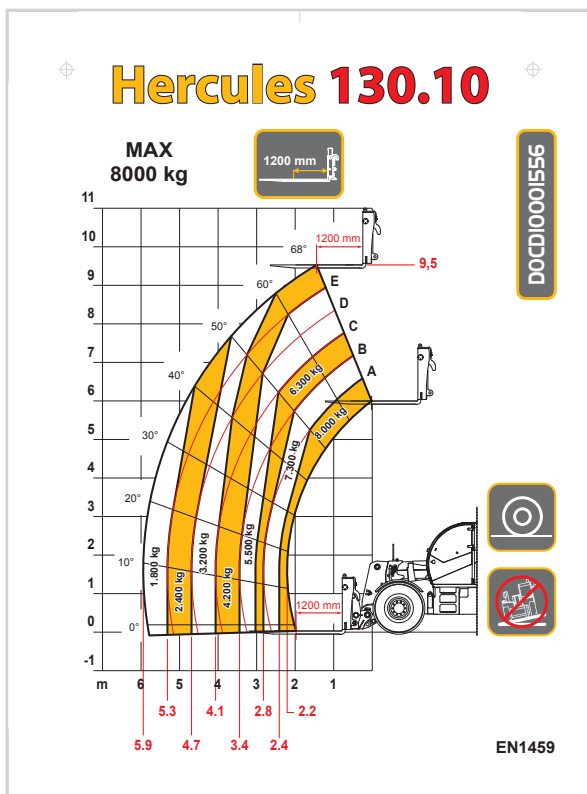
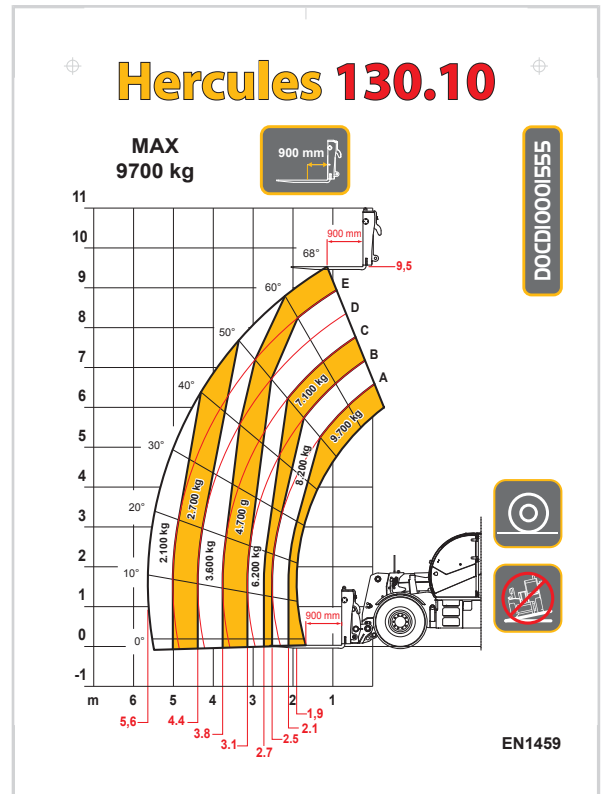
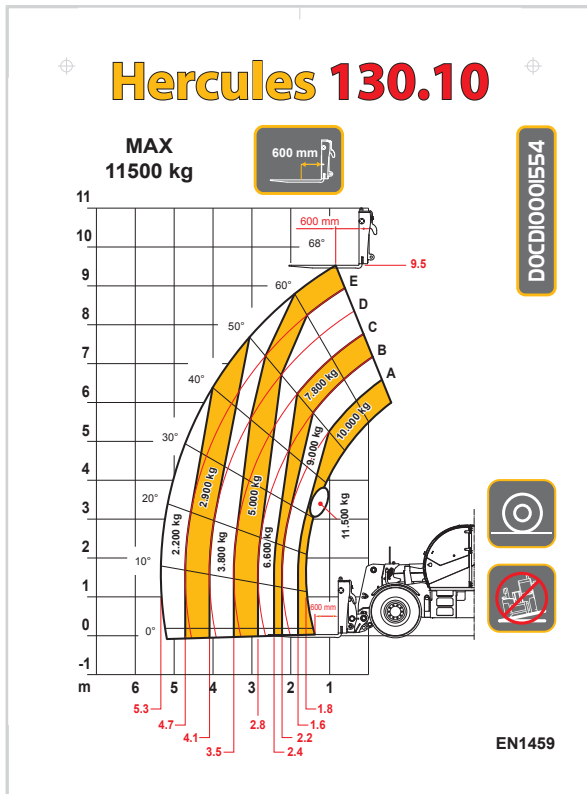

The Control Log and Maintenance Log are to be considered as integral parts of the vehicle and equipment.

These logs must therefore accompany the vehicle and equipment for their life, to final disposal.

### 23.1 - Type of logs

#### 23.1.1 - Control log

On the Control Log are recorded the main checks on the safety devices of the equipment, recommended by *Dieci S.r.l.*, with the related deadlines.

These checks ensure the proper operation of the safety devices.

**NOTE**

The checks specified in the Control Log are in addition to the routine maintenance described in the Maintenance Log.

#### 23.1.2 - Maintenance Log

On the Maintenance Log are recorded all scheduled maintenance with timelines, referred to the use in normal, and not heavy, conditions. Such maintenance interventions allow to keep the vehicle or the equipment in the best efficiency conditions.

The scheduled maintenance intervals frequency must be reduced even to daily, if necessary, in particularly heavy working conditions (humidity, mud, sand, high dust level, etc ...).

**NOTE**

Consult the *DIECI* service center to establish appropriate timelines when working in particularly heavy environments.

### 23.2 - Instructions for compiling the logs

#### 23.2.1 - Warnings on the control log

- The log must be prepared in accordance with the requirements imposed by the Essential Safety Requirement 4.4.2.b Annex I of the Machinery Directive 2006/42/EC, in order to preserve evidence of the proper conduct of all the inspection and maintenance activities concerning the vehicle safety.

- In the log, in addition to all the activities relating to the life, use and maintenance of safety systems of the vehicle (replacement of parts, overhauls, breakdowns, etc.) it is necessary to record all the checks required by the regulations in force in the country where the vehicle is used.

- It is also necessary that the name of the verifier technician and date of intervention are clearly identifiable.

- It is recommended to prepare, update and preserved with care, for the entire life of the vehicle or equipment, the control log.

**NOTE**

Here following there are some pages to allow compiling such logs.

Consult the Dieci s.r.l. service center to obtain more information regarding the availability of control and maintenance logs.

#### 23.2.2 - Warnings on the maintenance log

- The maintenance log shall prevail for warranty claims. All activities relating to the life, use and maintenance of the vehicle must be registered in the log.

#### 23.2.3 - Logs compiling

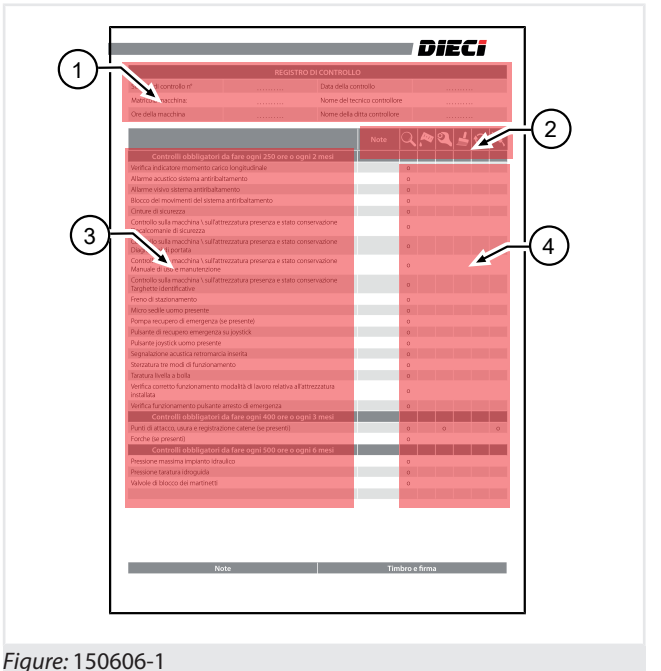

Figure: 150606-1

Each log (fig. 150606-1) requires the compilation of several parts:

1. Log data

2. Operations to carry out
3. Component or device on which to carry out the operation to be performed
4. Space that indicates the obligatory operation marked by the symbol "o", and the possibility to annotate an extraordinary operation not included in the log.

### 23.2.4 - Logs legend

Symbol	Description
	Control - Check
	Refilling
	Adjustment
	Cleaning
	Replacement
	Lubrication
	Maintenance at an authorized service center



23.2.5 - Intervals legend



**NOTE**

**The intervals are defined both in hours of work and in time intervals from the date of purchase.**

It is necessary to make interventions at the end of the first interval, either work hours or time.

Timelines	Description
0h	According to the need - To be completed in the case of checks not linked to deadlines but more or less related to the heavy operation of the vehicle
10h / 1m	Every 10 hours of operation or every month
50h / 1m	Every 50 hours of operation or every month
250h / 2m	Every 250 hours of operation or every 2 months
500h / 6m	Every 500 hours of operation or every 6 months
1000h / 1y	Every 1000 hours of operation or every year
2000h	Every 2000 hours of operation
4000h	Every 4000 hours of operation
2y	Every 2 years

### 23.3 - Periodic checks and recording mode (Italian only)

- The employer/operator of the vehicle is required to submit the vehicle to the periodic checks provided by law (Ministerial Decree 12/9/59 and Legislative Decree 81/08).
- He/she also has the obligation to comply with the maintenance and surveillance plan described in this Use and Maintenance Manual of the vehicle.
- The periodic inspection, testing and maintenance must be carried out by specialized personnel appointed for that purpose or by a workshop authorized by the manufacturer DIECI S.r.l.
- The employer/operator of the vehicle must record or appoint personnel trained for the purpose to record the results of the checks into the Control Log.
- Regular checks that have to be entered in the "Control log" are:
  - Quarterly periodic checks regarding the functionality and/or efficiency of ropes/chains according to Annex VI section 3.1.2 of Legislative Decree 81/08;
  - Yearly periodic checks regarding the operation and storage of the vehicle for safety purposes (yearly inspections, corrosion checks, calibration check, etc.) in accordance with Annex VII of Legislative Decree 81/08;
- The law provides administrative sanctions against those who do not carry out the quarterly and yearly checks.
- The Control Log, in which it is necessary to record the checks, must be shown upon request to the officials responsible for monitoring the current legislation.
- Following the yearly periodic check the Local Health Authority official (Dip.SSIA), or the private Enabled Party chosen, issues a suitability report or prescribes the necessary obligations. The user is obliged to preserve the check report together with the Control Log.
- The checks evaluation must be recorded in the following dedicated pages indicating the outcome of the check, date, signature and any comments of the party in charge.
- If the pages dedicated in this Manual are insufficient for the annotations made in the life of the vehicle, use additional sheets being careful to compile them in the same way.







### 23.4 - Obligation and how to report to I.N.A.I.L. (National institute for insurance against accidents at work) (Italy only)

- The Legislative Decree 81/08 - Annex VII prescribes the obligation, to employers and users of lifting equipment with motor with capacity > 200 kg and lifting platforms for persons, to report the successful commissioning to the competent authority of the territory of the vehicle (currently I.N.A.I.L.), specifying the place of installation of the vehicle so that the authority itself may carry out the first verification.
- The report to I.N.A.I.L. must be carried out by attaching to the vehicle commissioning report a copy of the EC Declaration of Conformity of machinery referred to in Annex IIA of the Legislative Decree 17/2010 - Machinery Directive 2006/42/ EC.
- The original statements (CE Declaration of Conformity - Annex IIA) must be retained by the customer.
- The report to I.N.A.I.L. must be carried out by means of the CIVA portal.

## 23.5 - Control log

The following are some sheets for filling in the Control Log.

CONTROL LOG			
Control sheet no.	.....	Control date	.....
Vehicle serial number:	.....	Controller technician name	.....
Vehicle hours	.....	Controller company name	.....

	Controls							
250h / 3m	Longitudinal load momentum indicator check	<input type="checkbox"/>						
250h / 3m	Audible tipping alarm	<input type="checkbox"/>						
250h / 3m	Visual tipping warning	<input type="checkbox"/>						
250h / 3m	Anti-tipping system movements block	<input type="checkbox"/>						
250h / 3m	Seat belts	<input type="checkbox"/>						
250h / 3m	Control over the vehicle \ equipment for the presence and status of conservation of Safety Stickers	<input type="checkbox"/>						
250h / 3m	Control over the vehicle \ equipment for the presence and conservation status of Capacity Diagrams	<input type="checkbox"/>						
250h / 3m	Control over the vehicle \ equipment for the presence and conservation status of the Use and maintenance manual	<input type="checkbox"/>						
250h / 3m	Control over the vehicle \ equipment for the presence and conservation status of Identification labels	<input type="checkbox"/>						
250h / 3m	Parking brake	<input type="checkbox"/>						
250h / 3m	Deadman seat microswitch	<input type="checkbox"/>						
250h / 3m	Emergency recovery pump (if any)	<input type="checkbox"/>						
250h / 3m	Emergency recovery button on joystick	<input type="checkbox"/>						
250h / 3m	Deadman joystick button	<input type="checkbox"/>						
250h / 3m	Reverse gear engaged acoustic signal	<input type="checkbox"/>						
250h / 3m	Three operation mode steering	<input type="checkbox"/>						
250h / 3m	Spirit level indication	<input type="checkbox"/>						
250h / 2m	Installed equipment working mode correct operation check	<input type="checkbox"/>						
250h / 2m	Emergency stop button operation check	<input type="checkbox"/>						
250h / 2m	Operation check consistent with the instructions in the cab	<input type="checkbox"/>						
400h / 3m	Chains (if any) coupling points, wear and adjustment	<input type="checkbox"/>		<input type="checkbox"/>			<input type="checkbox"/>	
400h / 3m	Forks (if present)	<input type="checkbox"/>						
500h / 6m	Hydraulic system maximum pressure	<input type="checkbox"/>						
500h / 6m	Power steering calibration pressure	<input type="checkbox"/>						
500h / 6m	Jacks block valves	<input type="checkbox"/>						







Notes	Stamp and signature

CONTROL LOG			
Control sheet no.	.....	Control date	.....
Vehicle serial number:	.....	Controller technician name	.....
Vehicle hours	.....	Controller company name	.....

Controls								
250h / 3m	Longitudinal load momentum indicator check	O						
250h / 3m	Audible tipping alarm	O						
250h / 3m	Visual tipping warning	O						
250h / 3m	Anti-tipping system movements block	O						
250h / 3m	Seat belts	O						
250h / 3m	Control over the vehicle \ equipment for the presence and status of conservation of Safety Stickers	O						
250h / 3m	Control over the vehicle \ equipment for the presence and conservation status of Capacity Diagrams	O						
250h / 3m	Control over the vehicle \ equipment for the presence and conservation status of the Use and maintenance manual	O						
250h / 3m	Control over the vehicle \ equipment for the presence and conservation status of Identification labels	O						
250h / 3m	Parking brake	O						
250h / 3m	Deadman seat microswitch	O						
250h / 3m	Emergency recovery pump (if any)	O						
250h / 3m	Emergency recovery button on joystick	O						
250h / 3m	Deadman joystick button	O						
250h / 3m	Reverse gear engaged acoustic signal	O						
250h / 3m	Three operation mode steering	O						
250h / 3m	Spirit level indication	O						
250h / 2m	Installed equipment working mode correct operation check	O						
250h / 2m	Emergency stop button operation check	O						
250h / 2m	Operation check consistent with the instructions in the cab	O						
400h / 3m	Chains (if any) coupling points, wear and adjustment	O		O			O	
400h / 3m	Forks (if present)	O						
500h / 6m	Hydraulic system maximum pressure	O						
500h / 6m	Power steering calibration pressure	O						
500h / 6m	Jacks block valves	O						

Notes	Stamp and signature

CONTROL LOG			
Control sheet no.	.....	Control date	.....
Vehicle serial number:	.....	Controller technician name	.....
Vehicle hours	.....	Controller company name	.....

Controls								
250h / 3m	Longitudinal load momentum indicator check	O						
250h / 3m	Audible tipping alarm	O						
250h / 3m	Visual tipping warning	O						
250h / 3m	Anti-tipping system movements block	O						
250h / 3m	Seat belts	O						
250h / 3m	Control over the vehicle \ equipment for the presence and status of conservation of Safety Stickers	O						
250h / 3m	Control over the vehicle \ equipment for the presence and conservation status of Capacity Diagrams	O						
250h / 3m	Control over the vehicle \ equipment for the presence and conservation status of the Use and maintenance manual	O						
250h / 3m	Control over the vehicle \ equipment for the presence and conservation status of Identification labels	O						
250h / 3m	Parking brake	O						
250h / 3m	Deadman seat microswitch	O						
250h / 3m	Emergency recovery pump (if any)	O						
250h / 3m	Emergency recovery button on joystick	O						
250h / 3m	Deadman joystick button	O						
250h / 3m	Reverse gear engaged acoustic signal	O						
250h / 3m	Three operation mode steering	O						
250h / 3m	Spirit level indication	O						
250h / 2m	Installed equipment working mode correct operation check	O						
250h / 2m	Emergency stop button operation check	O						
250h / 2m	Operation check consistent with the instructions in the cab	O						
400h / 3m	Chains (if any) coupling points, wear and adjustment	O		O			O	
400h / 3m	Forks (if present)	O						
500h / 6m	Hydraulic system maximum pressure	O						
500h / 6m	Power steering calibration pressure	O						
500h / 6m	Jacks block valves	O						







Notes	Stamp and signature

CONTROL LOG			
Control sheet no.	.....	Control date	.....
Vehicle serial number:	.....	Controller technician name	.....
Vehicle hours	.....	Controller company name	.....

Controls								
250h / 3m	Longitudinal load momentum indicator check	O						
250h / 3m	Audible tipping alarm	O						
250h / 3m	Visual tipping warning	O						
250h / 3m	Anti-tipping system movements block	O						
250h / 3m	Seat belts	O						
250h / 3m	Control over the vehicle \ equipment for the presence and status of conservation of Safety Stickers	O						
250h / 3m	Control over the vehicle \ equipment for the presence and conservation status of Capacity Diagrams	O						
250h / 3m	Control over the vehicle \ equipment for the presence and conservation status of the Use and maintenance manual	O						
250h / 3m	Control over the vehicle \ equipment for the presence and conservation status of Identification labels	O						
250h / 3m	Parking brake	O						
250h / 3m	Deadman seat microswitch	O						
250h / 3m	Emergency recovery pump (if any)	O						
250h / 3m	Emergency recovery button on joystick	O						
250h / 3m	Deadman joystick button	O						
250h / 3m	Reverse gear engaged acoustic signal	O						
250h / 3m	Three operation mode steering	O						
250h / 3m	Spirit level indication	O						
250h / 2m	Installed equipment working mode correct operation check	O						
250h / 2m	Emergency stop button operation check	O						
250h / 2m	Operation check consistent with the instructions in the cab	O						
400h / 3m	Chains (if any) coupling points, wear and adjustment	O		O			O	
400h / 3m	Forks (if present)	O						
500h / 6m	Hydraulic system maximum pressure	O						
500h / 6m	Power steering calibration pressure	O						
500h / 6m	Jacks block valves	O						

Notes	Stamp and signature

CONTROL LOG			
Control sheet no.	.....	Control date	.....
Vehicle serial number:	.....	Controller technician name	.....
Vehicle hours	.....	Controller company name	.....

	Controls							
250h / 3m	Longitudinal load momentum indicator check	O						
250h / 3m	Audible tipping alarm	O						
250h / 3m	Visual tipping warning	O						
250h / 3m	Anti-tipping system movements block	O						
250h / 3m	Seat belts	O						
250h / 3m	Control over the vehicle \ equipment for the presence and status of conservation of Safety Stickers	O						
250h / 3m	Control over the vehicle \ equipment for the presence and conservation status of Capacity Diagrams	O						
250h / 3m	Control over the vehicle \ equipment for the presence and conservation status of the Use and maintenance manual	O						
250h / 3m	Control over the vehicle \ equipment for the presence and conservation status of Identification labels	O						
250h / 3m	Parking brake	O						
250h / 3m	Deadman seat microswitch	O						
250h / 3m	Emergency recovery pump (if any)	O						
250h / 3m	Emergency recovery button on joystick	O						
250h / 3m	Deadman joystick button	O						
250h / 3m	Reverse gear engaged acoustic signal	O						
250h / 3m	Three operation mode steering	O						
250h / 3m	Spirit level indication	O						
250h / 2m	Installed equipment working mode correct operation check	O						
250h / 2m	Emergency stop button operation check	O						
250h / 2m	Operation check consistent with the instructions in the cab	O						
400h / 3m	Chains (if any) coupling points, wear and adjustment	O		O			O	
400h / 3m	Forks (if present)	O						
500h / 6m	Hydraulic system maximum pressure	O						
500h / 6m	Power steering calibration pressure	O						
500h / 6m	Jacks block valves	O						

Notes	Stamp and signature







CONTROL LOG			
Control sheet no.	.....	Control date	.....
Vehicle serial number:	.....	Controller technician name	.....
Vehicle hours	.....	Controller company name	.....

	Controls							
250h / 3m	Longitudinal load momentum indicator check	O						
250h / 3m	Audible tipping alarm	O						
250h / 3m	Visual tipping warning	O						
250h / 3m	Anti-tipping system movements block	O						
250h / 3m	Seat belts	O						
250h / 3m	Control over the vehicle \ equipment for the presence and status of conservation of Safety Stickers	O						
250h / 3m	Control over the vehicle \ equipment for the presence and conservation status of Capacity Diagrams	O						
250h / 3m	Control over the vehicle \ equipment for the presence and conservation status of the Use and maintenance manual	O						
250h / 3m	Control over the vehicle \ equipment for the presence and conservation status of Identification labels	O						
250h / 3m	Parking brake	O						
250h / 3m	Deadman seat microswitch	O						
250h / 3m	Emergency recovery pump (if any)	O						
250h / 3m	Emergency recovery button on joystick	O						
250h / 3m	Deadman joystick button	O						
250h / 3m	Reverse gear engaged acoustic signal	O						
250h / 3m	Three operation mode steering	O						
250h / 3m	Spirit level indication	O						
250h / 2m	Installed equipment working mode correct operation check	O						
250h / 2m	Emergency stop button operation check	O						
250h / 2m	Operation check consistent with the instructions in the cab	O						
400h / 3m	Chains (if any) coupling points, wear and adjustment	O		O			O	
400h / 3m	Forks (if present)	O						
500h / 6m	Hydraulic system maximum pressure	O						
500h / 6m	Power steering calibration pressure	O						
500h / 6m	Jacks block valves	O						

Notes	Stamp and signature



CONTROL LOG			
Control sheet no.	.....	Control date	.....
Vehicle serial number:	.....	Controller technician name	.....
Vehicle hours	.....	Controller company name	.....

	Controls							
250h / 3m	Longitudinal load momentum indicator check	O						
250h / 3m	Audible tipping alarm	O						
250h / 3m	Visual tipping warning	O						
250h / 3m	Anti-tipping system movements block	O						
250h / 3m	Seat belts	O						
250h / 3m	Control over the vehicle \ equipment for the presence and status of conservation of Safety Stickers	O						
250h / 3m	Control over the vehicle \ equipment for the presence and conservation status of Capacity Diagrams	O						
250h / 3m	Control over the vehicle \ equipment for the presence and conservation status of the Use and maintenance manual	O						
250h / 3m	Control over the vehicle \ equipment for the presence and conservation status of Identification labels	O						
250h / 3m	Parking brake	O						
250h / 3m	Deadman seat microswitch	O						
250h / 3m	Emergency recovery pump (if any)	O						
250h / 3m	Emergency recovery button on joystick	O						
250h / 3m	Deadman joystick button	O						
250h / 3m	Reverse gear engaged acoustic signal	O						
250h / 3m	Three operation mode steering	O						
250h / 3m	Spirit level indication	O						
250h / 2m	Installed equipment working mode correct operation check	O						
250h / 2m	Emergency stop button operation check	O						
250h / 2m	Operation check consistent with the instructions in the cab	O						
400h / 3m	Chains (if any) coupling points, wear and adjustment	O		O			O	
400h / 3m	Forks (if present)	O						
500h / 6m	Hydraulic system maximum pressure	O						
500h / 6m	Power steering calibration pressure	O						
500h / 6m	Jacks block valves	O						







Notes	Stamp and signature

CONTROL LOG			
Control sheet no.	.....	Control date	.....
Vehicle serial number:	.....	Controller technician name	.....
Vehicle hours	.....	Controller company name	.....

Controls								
250h / 3m	Longitudinal load momentum indicator check	O						
250h / 3m	Audible tipping alarm	O						
250h / 3m	Visual tipping warning	O						
250h / 3m	Anti-tipping system movements block	O						
250h / 3m	Seat belts	O						
250h / 3m	Control over the vehicle \ equipment for the presence and status of conservation of Safety Stickers	O						
250h / 3m	Control over the vehicle \ equipment for the presence and conservation status of Capacity Diagrams	O						
250h / 3m	Control over the vehicle \ equipment for the presence and conservation status of the Use and maintenance manual	O						
250h / 3m	Control over the vehicle \ equipment for the presence and conservation status of Identification labels	O						
250h / 3m	Parking brake	O						
250h / 3m	Deadman seat microswitch	O						
250h / 3m	Emergency recovery pump (if any)	O						
250h / 3m	Emergency recovery button on joystick	O						
250h / 3m	Deadman joystick button	O						
250h / 3m	Reverse gear engaged acoustic signal	O						
250h / 3m	Three operation mode steering	O						
250h / 3m	Spirit level indication	O						
250h / 2m	Installed equipment working mode correct operation check	O						
250h / 2m	Emergency stop button operation check	O						
250h / 2m	Operation check consistent with the instructions in the cab	O						
400h / 3m	Chains (if any) coupling points, wear and adjustment	O		O			O	
400h / 3m	Forks (if present)	O						
500h / 6m	Hydraulic system maximum pressure	O						
500h / 6m	Power steering calibration pressure	O						
500h / 6m	Jacks block valves	O						

Notes	Stamp and signature

CONTROL LOG			
Control sheet no.	.....	Control date	.....
Vehicle serial number:	.....	Controller technician name	.....
Vehicle hours	.....	Controller company name	.....

	Controls							
250h / 3m	Longitudinal load momentum indicator check	O						
250h / 3m	Audible tipping alarm	O						
250h / 3m	Visual tipping warning	O						
250h / 3m	Anti-tipping system movements block	O						
250h / 3m	Seat belts	O						
250h / 3m	Control over the vehicle \ equipment for the presence and status of conservation of Safety Stickers	O						
250h / 3m	Control over the vehicle \ equipment for the presence and conservation status of Capacity Diagrams	O						
250h / 3m	Control over the vehicle \ equipment for the presence and conservation status of the Use and maintenance manual	O						
250h / 3m	Control over the vehicle \ equipment for the presence and conservation status of Identification labels	O						
250h / 3m	Parking brake	O						
250h / 3m	Deadman seat microswitch	O						
250h / 3m	Emergency recovery pump (if any)	O						
250h / 3m	Emergency recovery button on joystick	O						
250h / 3m	Deadman joystick button	O						
250h / 3m	Reverse gear engaged acoustic signal	O						
250h / 3m	Three operation mode steering	O						
250h / 3m	Spirit level indication	O						
250h / 2m	Installed equipment working mode correct operation check	O						
250h / 2m	Emergency stop button operation check	O						
250h / 2m	Operation check consistent with the instructions in the cab	O						
400h / 3m	Chains (if any) coupling points, wear and adjustment	O		O			O	
400h / 3m	Forks (if present)	O						
500h / 6m	Hydraulic system maximum pressure	O						
500h / 6m	Power steering calibration pressure	O						
500h / 6m	Jacks block valves	O						

Notes	Stamp and signature

CONTROL LOG			
Control sheet no.	.....	Control date	.....
Vehicle serial number:	.....	Controller technician name	.....
Vehicle hours	.....	Controller company name	.....







Controls								
250h / 3m	Longitudinal load momentum indicator check	O						
250h / 3m	Audible tipping alarm	O						
250h / 3m	Visual tipping warning	O						
250h / 3m	Anti-tipping system movements block	O						
250h / 3m	Seat belts	O						
250h / 3m	Control over the vehicle \ equipment for the presence and status of conservation of Safety Stickers	O						
250h / 3m	Control over the vehicle \ equipment for the presence and conservation status of Capacity Diagrams	O						
250h / 3m	Control over the vehicle \ equipment for the presence and conservation status of the Use and maintenance manual	O						
250h / 3m	Control over the vehicle \ equipment for the presence and conservation status of Identification labels	O						
250h / 3m	Parking brake	O						
250h / 3m	Deadman seat microswitch	O						
250h / 3m	Emergency recovery pump (if any)	O						
250h / 3m	Emergency recovery button on joystick	O						
250h / 3m	Deadman joystick button	O						
250h / 3m	Reverse gear engaged acoustic signal	O						
250h / 3m	Three operation mode steering	O						
250h / 3m	Spirit level indication	O						
250h / 2m	Installed equipment working mode correct operation check	O						
250h / 2m	Emergency stop button operation check	O						
250h / 2m	Operation check consistent with the instructions in the cab	O						
400h / 3m	Chains (if any) coupling points, wear and adjustment	O		O			O	
400h / 3m	Forks (if present)	O						
500h / 6m	Hydraulic system maximum pressure	O						
500h / 6m	Power steering calibration pressure	O						
500h / 6m	Jacks block valves	O						







Notes	Stamp and signature

## 23.6 - Maintenance log

The following are some sheets for filling in the Maintenance Log for fixed vehicles.

MAINTENANCE LOG			
Maintenance sheet no.	.....	Maintenance date	.....
Vehicle serial number:	.....	Maintenance technician name	.....
Vehicle hours	.....	Maintenance company name	.....

	Maintenance							
0h	Air conditioning system	<input type="checkbox"/>			<input type="checkbox"/>			
0h	Anti-tipping device inspection with load	<input type="checkbox"/>						
0h	Filters (air, engine oil, hydraulic oil, fuel, air conditioning system, cab)	<input type="checkbox"/>						
0h	Brake			<input type="checkbox"/>				
0h	Parking brake	<input type="checkbox"/>						
0h	Electrolyte level and battery charge	<input type="checkbox"/>						
0h	Lighting	<input type="checkbox"/>						
0h	Hydraulic oil level	<input type="checkbox"/>						
0h	Alternator belts \ services	<input type="checkbox"/>						
0h	Engine oil level	<input type="checkbox"/>						
0h	Radiators	<input type="checkbox"/>			<input type="checkbox"/>			
0h	Radiator expansion tank	<input type="checkbox"/>	<input type="checkbox"/>					
0h	Tires pressure	<input type="checkbox"/>						
0h	Wear check (on both the vehicle and equipment if installed)	<input type="checkbox"/>						
10h / 1m	Window washer tank	<input type="checkbox"/>	<input type="checkbox"/>					
10h / 1m	Boom chains (if installed)	<input type="checkbox"/>						
10h / 1m	Safety stickers	<input type="checkbox"/>						
10h / 1m	Safety devices	<input type="checkbox"/>						
10h / 1m	Coolant	<input type="checkbox"/>						
10h / 1m	Engine oil level	<input type="checkbox"/>						
10h / 1m	Metal structural work, no cracks	<input type="checkbox"/>						
10h / 1m	Radiators				<input type="checkbox"/>			
50h / 1m	Grease level in the automatic lubrication system (if installed)						<input type="checkbox"/>	
50h / 1m	Prop shafts						<input type="checkbox"/>	
50h / 1m	Axles oscillation						<input type="checkbox"/>	
50h / 1m	Wheels reduction gear pins						<input type="checkbox"/>	
50h / 1m	Ropes and chains (if installed)	<input type="checkbox"/>					<input type="checkbox"/>	
50h / 1m	Wear pads	<input type="checkbox"/>					<input type="checkbox"/>	
50h / 1m	Mechanical joints of parking brake on the axle						<input type="checkbox"/>	
50h / 1m	Mechanical joints						<input type="checkbox"/>	
50h / 1m	Cab ventilation filter				<input type="checkbox"/>			
50h / 1m	Brakes oil level	<input type="checkbox"/>						







	Maintenance							
50h / 1m	Hydraulic oil level	o						
50h / 1m	Hydraulic system leaks	o						
50h / 1m	Air filter				o			
50h / 1m	Fuel filter				o			
50h / 1m	Coolant	o						
50h / 1m	Engine oil level	o						
50h / 1m	Tires pressure	o						
50h / 1m	Wheel nuts tightening	o						
50h / 1m	Inching oil level (only PS transmissions)	o						
First 100h	Differential axle oil					o		
First 100h	Pump actuation return oil					o		
250h / 2m	Ropes and chains (if any) coupling points, wear and adjustment	o		o			o	
250h / 2m	Boom chains (if installed)			o				
250h / 2m	Seat belts	o						
250h / 2m	Rear view mirrors	o						
250h / 2m	Anti-tipping device	o						
250h / 2m	Electrolyte level and battery charge	o						
250h / 2m	Torque specifications - Hydraulic Fittings			o				
250h / 2m	Alternator belts \ services	o		o				
250h / 2m	Torque specifications - fasteners			o				
500h / 6m	PTO gearbox oil (if installed)					o		
500h / 6m	Differential axle oil	o						
500h / 6m	Epicycloidal reduction gear oil	o						
500h / 6m	Forks: wear	o						
500h / 6m	Cab ventilation filter					o		
500h / 6m	Brakes oil					o		
500h / 6m	Electrical system	o						
500h / 6m	Hydraulic oil filter(s)					o		
500h / 6m	Block valves	o						
500h / 6m	Air filter					o		
500h / 6m	FPT fuel filter					o		
500h / 6m	FPT engine oil filter					o		
500h / 6m	FPT engine oil					o		
500h / 6m	KUBOTA fuel filter					o		
500h / 6m	KUBOTA engine oil filter					o		
500h / 6m	KUBOTA engine oil					o		
500h / 6m	Transmission oil	o						
500h / 6m	Pump actuation return oil					o		
1000h / 1y	PTO gearbox oil (if installed)					o		
1000h / 1y	Differential axle oil					o		
1000h / 1y	Epicycloidal reduction gear oil					o		
1000h / 1y	Equipment condition	o						**
1000h / 1y	Forks support plate: wear	o						**

Maintenance								
1000h / 1y	Telescopic boom: conditions	o						**
1000h / 1y	Telescopic boom: bearings and pivot bushes	o						**
1000h / 1y	Wear pads: wear	o						**
1000h / 1y	Cab structure	o						**
1000h / 1y	Brakes oil circuit				o			**
1000h / 1y	Brakes oil circuit: Pressure	o						**
1000h / 1y	Brake			o				**
1000h / 1y	Electrical system: cables condition	o						**
1000h / 1y	Electrical system: Lighting and signaling	o						**
1000h / 1y	Electrical system: Acoustic signal devices	o						**
1000h / 1y	Hydraulic system: Jacks	o						**
1000h / 1y	Hydraulic system: Pipes and flexible pipes	o						**
1000h / 1y	Hydraulic system: Movements speed	o						**
1000h / 1y	Hydraulic oil					o		
1000h / 1y	Engine valves clearances	o						**
1000h / 1y	Coolant					o		
1000h / 1y	Engine speeds	o						**
1000h / 1y	Fuel tank				o			
1000h / 1y	Wheels and tires conditions	o						**
1000h / 1y	Chassis: bearings and pivot bushes	o						**
1000h / 1y	Chassis: structure	o						**
1000h / 1y	Transmission oil					o		
2000h	Axles oscillation	o						**
2000h	Ropes and chains (if installed)					o		**
2000h	Hydraulic system: Capacity	o						**
2000h	Hydraulic system: Pressures	o						**

Maintenance								
2000h	Hydraulic oil tank				o			**
2000h	Alternator and Starter motor	o						**
2000h	Radiators	o			o			**
3600h	AdBlue tank filter FPT engine (only Stage IIIB/Tier 4i and Stage IV/Tier 4f engine sizes)					o		**
4000h	Prop shafts	o				o		**
4000h	Reduction gears universal joint	o						**
4000h	Wheels reduction gear clearance	o						**
4000h	Steering ball joints	o						**
4000h	Wheels reduction gear pins	o						**
4000h	Brakes wear	o						**
2y	Air conditioning system (if installed): Dissipater filter					o		**
2y	Air conditioning system (if installed): Oil refrigerant	o						**
2y	Air conditioning system (if installed): Pressure switches	o		o				**
2y	Air conditioning system (if installed): Condenser and evaporator coils				o			**
2y	Air conditioning system (if installed): Condensate and exhaust valve tank				o			**
Notes		Stamp and signature						



MAINTENANCE LOG			
Maintenance sheet no.	.....	Maintenance date	.....
Vehicle serial number:	.....	Maintenance technician name	.....
Vehicle hours	.....	Maintenance company name	.....







	Maintenance							
0h	Air conditioning system	<input type="checkbox"/>			<input type="checkbox"/>			
0h	Anti-tipping device inspection with load	<input type="checkbox"/>						
0h	Filters (air, engine oil, hydraulic oil, fuel, air conditioning system, cab)	<input type="checkbox"/>						
0h	Brake			<input type="checkbox"/>				
0h	Parking brake	<input type="checkbox"/>						
0h	Electrolyte level and battery charge	<input type="checkbox"/>						
0h	Lighting	<input type="checkbox"/>						
0h	Hydraulic oil level	<input type="checkbox"/>						
0h	Alternator belts \ services	<input type="checkbox"/>						
0h	Engine oil level	<input type="checkbox"/>						
0h	Radiators	<input type="checkbox"/>			<input type="checkbox"/>			
0h	Radiator expansion tank	<input type="checkbox"/>	<input type="checkbox"/>					
0h	Tires pressure	<input type="checkbox"/>						
0h	Wear check (on both the vehicle and equipment if installed)	<input type="checkbox"/>						
10h / 1m	Window washer tank	<input type="checkbox"/>	<input type="checkbox"/>					
10h / 1m	Boom chains (if installed)	<input type="checkbox"/>						
10h / 1m	Safety stickers	<input type="checkbox"/>						
10h / 1m	Safety devices	<input type="checkbox"/>						
10h / 1m	Coolant	<input type="checkbox"/>						
10h / 1m	Engine oil level	<input type="checkbox"/>						
10h / 1m	Metal structural work, no cracks	<input type="checkbox"/>						
10h / 1m	Radiators				<input type="checkbox"/>			
50h / 1m	Grease level in the automatic lubrication system (if installed)						<input type="checkbox"/>	
50h / 1m	Prop shafts						<input type="checkbox"/>	
50h / 1m	Axles oscillation						<input type="checkbox"/>	
50h / 1m	Wheels reduction gear pins						<input type="checkbox"/>	
50h / 1m	Ropes and chains (if installed)	<input type="checkbox"/>					<input type="checkbox"/>	
50h / 1m	Wear pads	<input type="checkbox"/>					<input type="checkbox"/>	
50h / 1m	Mechanical joints of parking brake on the axle						<input type="checkbox"/>	
50h / 1m	Mechanical joints						<input type="checkbox"/>	
50h / 1m	Cab ventilation filter				<input type="checkbox"/>			
50h / 1m	Brakes oil level	<input type="checkbox"/>						
50h / 1m	Hydraulic oil level	<input type="checkbox"/>						
50h / 1m	Hydraulic system leaks	<input type="checkbox"/>						
50h / 1m	Air filter				<input type="checkbox"/>			

	Maintenance							
50h / 1m	Fuel filter				o			
50h / 1m	Coolant	o						
50h / 1m	Engine oil level	o						
50h / 1m	Tires pressure	o						
50h / 1m	Wheel nuts tightening	o						
50h / 1m	Inching oil level (only PS transmissions)	o						
First 100h	Differential axle oil					o		
First 100h	Pump actuation return oil					o		
250h / 2m	Ropes and chains (if any) coupling points, wear and adjustment	o		o				o
250h / 2m	Boom chains (if installed)			o				
250h / 2m	Seat belts	o						
250h / 2m	Rear view mirrors	o						
250h / 2m	Anti-tipping device	o						
250h / 2m	Electrolyte level and battery charge	o						
250h / 2m	Torque specifications - Hydraulic Fittings			o				
250h / 2m	Alternator belts \ services	o		o				
250h / 2m	Torque specifications - fasteners			o				
500h / 6m	PTO gearbox oil (if installed)					o		
500h / 6m	Differential axle oil	o						
500h / 6m	Epicycloidal reduction gear oil	o						
500h / 6m	Forks: wear	o						
500h / 6m	Cab ventilation filter					o		
500h / 6m	Brakes oil					o		
500h / 6m	Electrical system	o						
500h / 6m	Hydraulic oil filter(s)					o		
500h / 6m	Block valves	o						
500h / 6m	Air filter					o		
500h / 6m	FPT fuel filter					o		
500h / 6m	FPT engine oil filter					o		
500h / 6m	FPT engine oil					o		
500h / 6m	KUBOTA fuel filter					o		
500h / 6m	KUBOTA engine oil filter					o		
500h / 6m	KUBOTA engine oil					o		
500h / 6m	Transmission oil	o						
500h / 6m	Pump actuation return oil					o		
1000h / 1y	PTO gearbox oil (if installed)					o		
1000h / 1y	Differential axle oil					o		
1000h / 1y	Epicycloidal reduction gear oil					o		
1000h / 1y	Equipment condition	o						**
1000h / 1y	Forks support plate: wear	o						**
1000h / 1y	Telescopic boom: conditions	o						**
1000h / 1y	Telescopic boom: bearings and pivot bushes	o						**
1000h / 1y	Wear pads: wear	o						**

Maintenance								
1000h / 1y	Cab structure	o						**
1000h / 1y	Brakes oil circuit				o			**
1000h / 1y	Brakes oil circuit: Pressure	o						**
1000h / 1y	Brake			o				**
1000h / 1y	Electrical system: cables condition	o						**
1000h / 1y	Electrical system: Lighting and signaling	o						**
1000h / 1y	Electrical system: Acoustic signal devices	o						**
1000h / 1y	Hydraulic system: Jacks	o						**
1000h / 1y	Hydraulic system: Pipes and flexible pipes	o						**
1000h / 1y	Hydraulic system: Movements speed	o						**
1000h / 1y	Hydraulic oil					o		
1000h / 1y	Engine valves clearances	o						**
1000h / 1y	Coolant					o		
1000h / 1y	Engine speeds	o						**
1000h / 1y	Fuel tank				o			
1000h / 1y	Wheels and tires conditions	o						**
1000h / 1y	Chassis: bearings and pivot bushes	o						**
1000h / 1y	Chassis: structure	o						**
1000h / 1y	Transmission oil					o		
2000h	Axles oscillation	o						**
2000h	Ropes and chains (if installed)					o		**
2000h	Hydraulic system: Capacity	o						**
2000h	Hydraulic system: Pressures	o						**
2000h	Hydraulic oil tank				o			**
2000h	Alternator and Starter motor	o						**
2000h	Radiators	o			o			**
3600h	AdBlue tank filter FPT engine (only Stage IIIB/Tier 4i and Stage IV/Tier 4f engine sizes)					o		**
4000h	Prop shafts	o				o		**

Maintenance								
4000h	Reduction gears universal joint	o						**
4000h	Wheels reduction gear clearance	o						**
4000h	Steering ball joints	o						**
4000h	Wheels reduction gear pins	o						**
4000h	Brakes wear	o						**
2y	Air conditioning system (if installed): Dissipater filter					o		**
2y	Air conditioning system (if installed): Oil refrigerant	o						**
2y	Air conditioning system (if installed): Pressure switches	o		o				**
2y	Air conditioning system (if installed): Condenser and evaporator coils				o			**
2y	Air conditioning system (if installed): Condensate and exhaust valve tank				o			**
Notes		Stamp and signature						

MAINTENANCE LOG			
Maintenance sheet no.	.....	Maintenance date	.....
Vehicle serial number:	.....	Maintenance technician name	.....
Vehicle hours	.....	Maintenance company name	.....

	Maintenance							
0h	Air conditioning system	<input type="checkbox"/>			<input type="checkbox"/>			
0h	Anti-tipping device inspection with load	<input type="checkbox"/>						
0h	Filters (air, engine oil, hydraulic oil, fuel, air conditioning system, cab)	<input type="checkbox"/>						
0h	Brake			<input type="checkbox"/>				
0h	Parking brake	<input type="checkbox"/>						
0h	Electrolyte level and battery charge	<input type="checkbox"/>						
0h	Lighting	<input type="checkbox"/>						
0h	Hydraulic oil level	<input type="checkbox"/>						
0h	Alternator belts \ services	<input type="checkbox"/>						
0h	Engine oil level	<input type="checkbox"/>						
0h	Radiators	<input type="checkbox"/>			<input type="checkbox"/>			
0h	Radiator expansion tank	<input type="checkbox"/>	<input type="checkbox"/>					
0h	Tires pressure	<input type="checkbox"/>						
0h	Wear check (on both the vehicle and equipment if installed)	<input type="checkbox"/>						
10h / 1m	Window washer tank	<input type="checkbox"/>	<input type="checkbox"/>					
10h / 1m	Boom chains (if installed)	<input type="checkbox"/>						
10h / 1m	Safety stickers	<input type="checkbox"/>						
10h / 1m	Safety devices	<input type="checkbox"/>						
10h / 1m	Coolant	<input type="checkbox"/>						
10h / 1m	Engine oil level	<input type="checkbox"/>						
10h / 1m	Metal structural work, no cracks	<input type="checkbox"/>						
10h / 1m	Radiators				<input type="checkbox"/>			
50h / 1m	Grease level in the automatic lubrication system (if installed)						<input type="checkbox"/>	
50h / 1m	Prop shafts						<input type="checkbox"/>	
50h / 1m	Axles oscillation						<input type="checkbox"/>	
50h / 1m	Wheels reduction gear pins						<input type="checkbox"/>	
50h / 1m	Ropes and chains (if installed)	<input type="checkbox"/>					<input type="checkbox"/>	
50h / 1m	Wear pads	<input type="checkbox"/>					<input type="checkbox"/>	
50h / 1m	Mechanical joints of parking brake on the axle						<input type="checkbox"/>	
50h / 1m	Mechanical joints						<input type="checkbox"/>	
50h / 1m	Cab ventilation filter				<input type="checkbox"/>			
50h / 1m	Brakes oil level	<input type="checkbox"/>						
50h / 1m	Hydraulic oil level	<input type="checkbox"/>						
50h / 1m	Hydraulic system leaks	<input type="checkbox"/>						
50h / 1m	Air filter				<input type="checkbox"/>			

	Maintenance							
50h / 1m	Fuel filter				o			
50h / 1m	Coolant	o						
50h / 1m	Engine oil level	o						
50h / 1m	Tires pressure	o						
50h / 1m	Wheel nuts tightening	o						
50h / 1m	Inching oil level (only PS transmissions)	o						
First 100h	Differential axle oil					o		
First 100h	Pump actuation return oil					o		
250h / 2m	Ropes and chains (if any) coupling points, wear and adjustment	o		o				o
250h / 2m	Boom chains (if installed)			o				
250h / 2m	Seat belts	o						
250h / 2m	Rear view mirrors	o						
250h / 2m	Anti-tipping device	o						
250h / 2m	Electrolyte level and battery charge	o						
250h / 2m	Torque specifications - Hydraulic Fittings			o				
250h / 2m	Alternator belts \ services	o		o				
250h / 2m	Torque specifications - fasteners			o				
500h / 6m	PTO gearbox oil (if installed)					o		
500h / 6m	Differential axle oil	o						
500h / 6m	Epicycloidal reduction gear oil	o						
500h / 6m	Forks: wear	o						
500h / 6m	Cab ventilation filter					o		
500h / 6m	Brakes oil					o		
500h / 6m	Electrical system	o						
500h / 6m	Hydraulic oil filter(s)					o		
500h / 6m	Block valves	o						
500h / 6m	Air filter					o		
500h / 6m	FPT fuel filter					o		
500h / 6m	FPT engine oil filter					o		
500h / 6m	FPT engine oil					o		
500h / 6m	KUBOTA fuel filter					o		
500h / 6m	KUBOTA engine oil filter					o		
500h / 6m	KUBOTA engine oil					o		
500h / 6m	Transmission oil	o						
500h / 6m	Pump actuation return oil					o		
1000h / 1y	PTO gearbox oil (if installed)					o		
1000h / 1y	Differential axle oil					o		
1000h / 1y	Epicycloidal reduction gear oil					o		
1000h / 1y	Equipment condition	o						**
1000h / 1y	Forks support plate: wear	o						**
1000h / 1y	Telescopic boom: conditions	o						**
1000h / 1y	Telescopic boom: bearings and pivot bushes	o						**
1000h / 1y	Wear pads: wear	o						**







Maintenance								
1000h / 1y	Cab structure	o						**
1000h / 1y	Brakes oil circuit				o			**
1000h / 1y	Brakes oil circuit: Pressure	o						**
1000h / 1y	Brake			o				**
1000h / 1y	Electrical system: cables condition	o						**
1000h / 1y	Electrical system: Lighting and signaling	o						**
1000h / 1y	Electrical system: Acoustic signal devices	o						**
1000h / 1y	Hydraulic system: Jacks	o						**
1000h / 1y	Hydraulic system: Pipes and flexible pipes	o						**
1000h / 1y	Hydraulic system: Movements speed	o						**
1000h / 1y	Hydraulic oil					o		
1000h / 1y	Engine valves clearances	o						**
1000h / 1y	Coolant					o		
1000h / 1y	Engine speeds	o						**
1000h / 1y	Fuel tank				o			
1000h / 1y	Wheels and tires conditions	o						**
1000h / 1y	Chassis: bearings and pivot bushes	o						**
1000h / 1y	Chassis: structure	o						**
1000h / 1y	Transmission oil					o		
2000h	Axles oscillation	o						**
2000h	Ropes and chains (if installed)					o		**
2000h	Hydraulic system: Capacity	o						**
2000h	Hydraulic system: Pressures	o						**
2000h	Hydraulic oil tank				o			**
2000h	Alternator and Starter motor	o						**
2000h	Radiators	o			o			**
3600h	AdBlue tank filter FPT engine (only Stage IIIB/Tier 4i and Stage IV/Tier 4f engine sizes)					o		**
4000h	Prop shafts	o				o		**



Maintenance								
4000h	Reduction gears universal joint	o						**
4000h	Wheels reduction gear clearance	o						**
4000h	Steering ball joints	o						**
4000h	Wheels reduction gear pins	o						**
4000h	Brakes wear	o						**
2y	Air conditioning system (if installed): Dissipater filter					o		**
2y	Air conditioning system (if installed): Oil refrigerant	o						**
2y	Air conditioning system (if installed): Pressure switches	o		o				**
2y	Air conditioning system (if installed): Condenser and evaporator coils				o			**
2y	Air conditioning system (if installed): Condensate and exhaust valve tank				o			**

Notes	Stamp and signature



MAINTENANCE LOG			
Maintenance sheet no.	.....	Maintenance date	.....
Vehicle serial number:	.....	Maintenance technician name	.....
Vehicle hours	.....	Maintenance company name	.....







	Maintenance							
0h	Air conditioning system	<input type="checkbox"/>			<input type="checkbox"/>			
0h	Anti-tipping device inspection with load	<input type="checkbox"/>						
0h	Filters (air, engine oil, hydraulic oil, fuel, air conditioning system, cab)	<input type="checkbox"/>						
0h	Brake			<input type="checkbox"/>				
0h	Parking brake	<input type="checkbox"/>						
0h	Electrolyte level and battery charge	<input type="checkbox"/>						
0h	Lighting	<input type="checkbox"/>						
0h	Hydraulic oil level	<input type="checkbox"/>						
0h	Alternator belts \ services	<input type="checkbox"/>						
0h	Engine oil level	<input type="checkbox"/>						
0h	Radiators	<input type="checkbox"/>			<input type="checkbox"/>			
0h	Radiator expansion tank	<input type="checkbox"/>	<input type="checkbox"/>					
0h	Tires pressure	<input type="checkbox"/>						
0h	Wear check (on both the vehicle and equipment if installed)	<input type="checkbox"/>						
10h / 1m	Window washer tank	<input type="checkbox"/>	<input type="checkbox"/>					
10h / 1m	Boom chains (if installed)	<input type="checkbox"/>						
10h / 1m	Safety stickers	<input type="checkbox"/>						
10h / 1m	Safety devices	<input type="checkbox"/>						
10h / 1m	Coolant	<input type="checkbox"/>						
10h / 1m	Engine oil level	<input type="checkbox"/>						
10h / 1m	Metal structural work, no cracks	<input type="checkbox"/>						
10h / 1m	Radiators				<input type="checkbox"/>			
50h / 1m	Grease level in the automatic lubrication system (if installed)						<input type="checkbox"/>	
50h / 1m	Prop shafts						<input type="checkbox"/>	
50h / 1m	Axles oscillation						<input type="checkbox"/>	
50h / 1m	Wheels reduction gear pins						<input type="checkbox"/>	
50h / 1m	Ropes and chains (if installed)	<input type="checkbox"/>					<input type="checkbox"/>	
50h / 1m	Wear pads	<input type="checkbox"/>					<input type="checkbox"/>	
50h / 1m	Mechanical joints of parking brake on the axle						<input type="checkbox"/>	
50h / 1m	Mechanical joints						<input type="checkbox"/>	
50h / 1m	Cab ventilation filter				<input type="checkbox"/>			
50h / 1m	Brakes oil level	<input type="checkbox"/>						
50h / 1m	Hydraulic oil level	<input type="checkbox"/>						
50h / 1m	Hydraulic system leaks	<input type="checkbox"/>						
50h / 1m	Air filter				<input type="checkbox"/>			

	Maintenance							
50h / 1m	Fuel filter				o			
50h / 1m	Coolant	o						
50h / 1m	Engine oil level	o						
50h / 1m	Tires pressure	o						
50h / 1m	Wheel nuts tightening	o						
50h / 1m	Inching oil level (only PS transmissions)	o						
First 100h	Differential axle oil					o		
First 100h	Pump actuation return oil					o		
250h / 2m	Ropes and chains (if any) coupling points, wear and adjustment	o		o				o
250h / 2m	Boom chains (if installed)			o				
250h / 2m	Seat belts	o						
250h / 2m	Rear view mirrors	o						
250h / 2m	Anti-tipping device	o						
250h / 2m	Electrolyte level and battery charge	o						
250h / 2m	Torque specifications - Hydraulic Fittings			o				
250h / 2m	Alternator belts \ services	o		o				
250h / 2m	Torque specifications - fasteners			o				
500h / 6m	PTO gearbox oil (if installed)					o		
500h / 6m	Differential axle oil	o						
500h / 6m	Epicycloidal reduction gear oil	o						
500h / 6m	Forks: wear	o						
500h / 6m	Cab ventilation filter					o		
500h / 6m	Brakes oil					o		
500h / 6m	Electrical system	o						
500h / 6m	Hydraulic oil filter(s)					o		
500h / 6m	Block valves	o						
500h / 6m	Air filter					o		
500h / 6m	FPT fuel filter					o		
500h / 6m	FPT engine oil filter					o		
500h / 6m	FPT engine oil					o		
500h / 6m	KUBOTA fuel filter					o		
500h / 6m	KUBOTA engine oil filter					o		
500h / 6m	KUBOTA engine oil					o		
500h / 6m	Transmission oil	o						
500h / 6m	Pump actuation return oil					o		
1000h / 1y	PTO gearbox oil (if installed)					o		
1000h / 1y	Differential axle oil					o		
1000h / 1y	Epicycloidal reduction gear oil					o		
1000h / 1y	Equipment condition	o						**
1000h / 1y	Forks support plate: wear	o						**
1000h / 1y	Telescopic boom: conditions	o						**
1000h / 1y	Telescopic boom: bearings and pivot bushes	o						**
1000h / 1y	Wear pads: wear	o						**

Maintenance								
1000h / 1y	Cab structure	o						**
1000h / 1y	Brakes oil circuit				o			**
1000h / 1y	Brakes oil circuit: Pressure	o						**
1000h / 1y	Brake			o				**
1000h / 1y	Electrical system: cables condition	o						**
1000h / 1y	Electrical system: Lighting and signaling	o						**
1000h / 1y	Electrical system: Acoustic signal devices	o						**
1000h / 1y	Hydraulic system: Jacks	o						**
1000h / 1y	Hydraulic system: Pipes and flexible pipes	o						**
1000h / 1y	Hydraulic system: Movements speed	o						**
1000h / 1y	Hydraulic oil					o		
1000h / 1y	Engine valves clearances	o						**
1000h / 1y	Coolant					o		
1000h / 1y	Engine speeds	o						**
1000h / 1y	Fuel tank				o			
1000h / 1y	Wheels and tires conditions	o						**
1000h / 1y	Chassis: bearings and pivot bushes	o						**
1000h / 1y	Chassis: structure	o						**
1000h / 1y	Transmission oil					o		
2000h	Axles oscillation	o						**
2000h	Ropes and chains (if installed)					o		**
2000h	Hydraulic system: Capacity	o						**
2000h	Hydraulic system: Pressures	o						**
2000h	Hydraulic oil tank				o			**
2000h	Alternator and Starter motor	o						**
2000h	Radiators	o			o			**
3600h	AdBlue tank filter FPT engine (only Stage IIIB/Tier 4i and Stage IV/Tier 4f engine sizes)					o		**
4000h	Prop shafts	o				o		**

Maintenance								
4000h	Reduction gears universal joint	o						**
4000h	Wheels reduction gear clearance	o						**
4000h	Steering ball joints	o						**
4000h	Wheels reduction gear pins	o						**
4000h	Brakes wear	o						**
2y	Air conditioning system (if installed): Dissipater filter					o		**
2y	Air conditioning system (if installed): Oil refrigerant	o						**
2y	Air conditioning system (if installed): Pressure switches	o		o				**
2y	Air conditioning system (if installed): Condenser and evaporator coils				o			**
2y	Air conditioning system (if installed): Condensate and exhaust valve tank				o			**
Notes		Stamp and signature						

MAINTENANCE LOG			
Maintenance sheet no.	.....	Maintenance date	.....
Vehicle serial number:	.....	Maintenance technician name	.....
Vehicle hours	.....	Maintenance company name	.....

	Maintenance							
0h	Air conditioning system	<input type="checkbox"/>			<input type="checkbox"/>			
0h	Anti-tipping device inspection with load	<input type="checkbox"/>						
0h	Filters (air, engine oil, hydraulic oil, fuel, air conditioning system, cab)	<input type="checkbox"/>						
0h	Brake			<input type="checkbox"/>				
0h	Parking brake	<input type="checkbox"/>						
0h	Electrolyte level and battery charge	<input type="checkbox"/>						
0h	Lighting	<input type="checkbox"/>						
0h	Hydraulic oil level	<input type="checkbox"/>						
0h	Alternator belts \ services	<input type="checkbox"/>						
0h	Engine oil level	<input type="checkbox"/>						
0h	Radiators	<input type="checkbox"/>			<input type="checkbox"/>			
0h	Radiator expansion tank	<input type="checkbox"/>	<input type="checkbox"/>					
0h	Tires pressure	<input type="checkbox"/>						
0h	Wear check (on both the vehicle and equipment if installed)	<input type="checkbox"/>						
10h / 1m	Window washer tank	<input type="checkbox"/>	<input type="checkbox"/>					
10h / 1m	Boom chains (if installed)	<input type="checkbox"/>						
10h / 1m	Safety stickers	<input type="checkbox"/>						
10h / 1m	Safety devices	<input type="checkbox"/>						
10h / 1m	Coolant	<input type="checkbox"/>						
10h / 1m	Engine oil level	<input type="checkbox"/>						
10h / 1m	Metal structural work, no cracks	<input type="checkbox"/>						
10h / 1m	Radiators				<input type="checkbox"/>			
50h / 1m	Grease level in the automatic lubrication system (if installed)						<input type="checkbox"/>	
50h / 1m	Prop shafts						<input type="checkbox"/>	
50h / 1m	Axles oscillation						<input type="checkbox"/>	
50h / 1m	Wheels reduction gear pins						<input type="checkbox"/>	
50h / 1m	Ropes and chains (if installed)	<input type="checkbox"/>					<input type="checkbox"/>	
50h / 1m	Wear pads	<input type="checkbox"/>					<input type="checkbox"/>	
50h / 1m	Mechanical joints of parking brake on the axle						<input type="checkbox"/>	
50h / 1m	Mechanical joints						<input type="checkbox"/>	
50h / 1m	Cab ventilation filter				<input type="checkbox"/>			
50h / 1m	Brakes oil level	<input type="checkbox"/>						
50h / 1m	Hydraulic oil level	<input type="checkbox"/>						
50h / 1m	Hydraulic system leaks	<input type="checkbox"/>						
50h / 1m	Air filter				<input type="checkbox"/>			

	Maintenance							
50h / 1m	Fuel filter				o			
50h / 1m	Coolant	o						
50h / 1m	Engine oil level	o						
50h / 1m	Tires pressure	o						
50h / 1m	Wheel nuts tightening	o						
50h / 1m	Inching oil level (only PS transmissions)	o						
First 100h	Differential axle oil					o		
First 100h	Pump actuation return oil					o		
250h / 2m	Ropes and chains (if any) coupling points, wear and adjustment	o		o				o
250h / 2m	Boom chains (if installed)			o				
250h / 2m	Seat belts	o						
250h / 2m	Rear view mirrors	o						
250h / 2m	Anti-tipping device	o						
250h / 2m	Electrolyte level and battery charge	o						
250h / 2m	Torque specifications - Hydraulic Fittings			o				
250h / 2m	Alternator belts \ services	o		o				
250h / 2m	Torque specifications - fasteners			o				
500h / 6m	PTO gearbox oil (if installed)					o		
500h / 6m	Differential axle oil	o						
500h / 6m	Epicycloidal reduction gear oil	o						
500h / 6m	Forks: wear	o						
500h / 6m	Cab ventilation filter					o		
500h / 6m	Brakes oil					o		
500h / 6m	Electrical system	o						
500h / 6m	Hydraulic oil filter(s)					o		
500h / 6m	Block valves	o						
500h / 6m	Air filter					o		
500h / 6m	FPT fuel filter					o		
500h / 6m	FPT engine oil filter					o		
500h / 6m	FPT engine oil					o		
500h / 6m	KUBOTA fuel filter					o		
500h / 6m	KUBOTA engine oil filter					o		
500h / 6m	KUBOTA engine oil					o		
500h / 6m	Transmission oil	o						
500h / 6m	Pump actuation return oil					o		
1000h / 1y	PTO gearbox oil (if installed)					o		
1000h / 1y	Differential axle oil					o		
1000h / 1y	Epicycloidal reduction gear oil					o		
1000h / 1y	Equipment condition	o						**
1000h / 1y	Forks support plate: wear	o						**
1000h / 1y	Telescopic boom: conditions	o						**
1000h / 1y	Telescopic boom: bearings and pivot bushes	o						**
1000h / 1y	Wear pads: wear	o						**







Maintenance								
1000h / 1y	Cab structure	o						**
1000h / 1y	Brakes oil circuit				o			**
1000h / 1y	Brakes oil circuit: Pressure	o						**
1000h / 1y	Brake			o				**
1000h / 1y	Electrical system: cables condition	o						**
1000h / 1y	Electrical system: Lighting and signaling	o						**
1000h / 1y	Electrical system: Acoustic signal devices	o						**
1000h / 1y	Hydraulic system: Jacks	o						**
1000h / 1y	Hydraulic system: Pipes and flexible pipes	o						**
1000h / 1y	Hydraulic system: Movements speed	o						**
1000h / 1y	Hydraulic oil					o		
1000h / 1y	Engine valves clearances	o						**
1000h / 1y	Coolant					o		
1000h / 1y	Engine speeds	o						**
1000h / 1y	Fuel tank				o			
1000h / 1y	Wheels and tires conditions	o						**
1000h / 1y	Chassis: bearings and pivot bushes	o						**
1000h / 1y	Chassis: structure	o						**
1000h / 1y	Transmission oil					o		
2000h	Axles oscillation	o						**
2000h	Ropes and chains (if installed)					o		**
2000h	Hydraulic system: Capacity	o						**
2000h	Hydraulic system: Pressures	o						**
2000h	Hydraulic oil tank				o			**
2000h	Alternator and Starter motor	o						**
2000h	Radiators	o			o			**
3600h	AdBlue tank filter FPT engine (only Stage IIIB/Tier 4i and Stage IV/ Tier 4f engine sizes)					o		**
4000h	Prop shafts	o				o		**

Maintenance								
4000h	Reduction gears universal joint	o						**
4000h	Wheels reduction gear clearance	o						**
4000h	Steering ball joints	o						**
4000h	Wheels reduction gear pins	o						**
4000h	Brakes wear	o						**
2y	Air conditioning system (if installed): Dissipater filter					o		**
2y	Air conditioning system (if installed): Oil refrigerant	o						**
2y	Air conditioning system (if installed): Pressure switches	o		o				**
2y	Air conditioning system (if installed): Condenser and evaporator coils				o			**
2y	Air conditioning system (if installed): Condensate and exhaust valve tank				o			**

Notes	Stamp and signature



MAINTENANCE LOG			
Maintenance sheet no.	.....	Maintenance date	.....
Vehicle serial number:	.....	Maintenance technician name	.....
Vehicle hours	.....	Maintenance company name	.....

	Maintenance							
0h	Air conditioning system	<input type="checkbox"/>			<input type="checkbox"/>			
0h	Anti-tipping device inspection with load	<input type="checkbox"/>						
0h	Filters (air, engine oil, hydraulic oil, fuel, air conditioning system, cab)	<input type="checkbox"/>						
0h	Brake			<input type="checkbox"/>				
0h	Parking brake	<input type="checkbox"/>						
0h	Electrolyte level and battery charge	<input type="checkbox"/>						
0h	Lighting	<input type="checkbox"/>						
0h	Hydraulic oil level	<input type="checkbox"/>						
0h	Alternator belts \ services	<input type="checkbox"/>						
0h	Engine oil level	<input type="checkbox"/>						
0h	Radiators	<input type="checkbox"/>			<input type="checkbox"/>			
0h	Radiator expansion tank	<input type="checkbox"/>	<input type="checkbox"/>					
0h	Tires pressure	<input type="checkbox"/>						
0h	Wear check (on both the vehicle and equipment if installed)	<input type="checkbox"/>						
10h / 1m	Window washer tank	<input type="checkbox"/>	<input type="checkbox"/>					
10h / 1m	Boom chains (if installed)	<input type="checkbox"/>						
10h / 1m	Safety stickers	<input type="checkbox"/>						
10h / 1m	Safety devices	<input type="checkbox"/>						
10h / 1m	Coolant	<input type="checkbox"/>						
10h / 1m	Engine oil level	<input type="checkbox"/>						
10h / 1m	Metal structural work, no cracks	<input type="checkbox"/>						
10h / 1m	Radiators				<input type="checkbox"/>			
50h / 1m	Grease level in the automatic lubrication system (if installed)						<input type="checkbox"/>	
50h / 1m	Prop shafts						<input type="checkbox"/>	
50h / 1m	Axles oscillation						<input type="checkbox"/>	
50h / 1m	Wheels reduction gear pins						<input type="checkbox"/>	
50h / 1m	Ropes and chains (if installed)	<input type="checkbox"/>					<input type="checkbox"/>	
50h / 1m	Wear pads	<input type="checkbox"/>					<input type="checkbox"/>	
50h / 1m	Mechanical joints of parking brake on the axle						<input type="checkbox"/>	
50h / 1m	Mechanical joints						<input type="checkbox"/>	
50h / 1m	Cab ventilation filter				<input type="checkbox"/>			
50h / 1m	Brakes oil level	<input type="checkbox"/>						
50h / 1m	Hydraulic oil level	<input type="checkbox"/>						
50h / 1m	Hydraulic system leaks	<input type="checkbox"/>						
50h / 1m	Air filter				<input type="checkbox"/>			







	Maintenance							
50h / 1m	Fuel filter				o			
50h / 1m	Coolant	o						
50h / 1m	Engine oil level	o						
50h / 1m	Tires pressure	o						
50h / 1m	Wheel nuts tightening	o						
50h / 1m	Inching oil level (only PS transmissions)	o						
First 100h	Differential axle oil					o		
First 100h	Pump actuation return oil					o		
250h / 2m	Ropes and chains (if any) coupling points, wear and adjustment	o		o				o
250h / 2m	Boom chains (if installed)			o				
250h / 2m	Seat belts	o						
250h / 2m	Rear view mirrors	o						
250h / 2m	Anti-tipping device	o						
250h / 2m	Electrolyte level and battery charge	o						
250h / 2m	Torque specifications - Hydraulic Fittings			o				
250h / 2m	Alternator belts \ services	o		o				
250h / 2m	Torque specifications - fasteners			o				
500h / 6m	PTO gearbox oil (if installed)					o		
500h / 6m	Differential axle oil	o						
500h / 6m	Epicycloidal reduction gear oil	o						
500h / 6m	Forks: wear	o						
500h / 6m	Cab ventilation filter					o		
500h / 6m	Brakes oil					o		
500h / 6m	Electrical system	o						
500h / 6m	Hydraulic oil filter(s)					o		
500h / 6m	Block valves	o						
500h / 6m	Air filter					o		
500h / 6m	FPT fuel filter					o		
500h / 6m	FPT engine oil filter					o		
500h / 6m	FPT engine oil					o		
500h / 6m	KUBOTA fuel filter					o		
500h / 6m	KUBOTA engine oil filter					o		
500h / 6m	KUBOTA engine oil					o		
500h / 6m	Transmission oil	o						
500h / 6m	Pump actuation return oil					o		
1000h / 1y	PTO gearbox oil (if installed)					o		
1000h / 1y	Differential axle oil					o		
1000h / 1y	Epicycloidal reduction gear oil					o		
1000h / 1y	Equipment condition	o						**
1000h / 1y	Forks support plate: wear	o						**
1000h / 1y	Telescopic boom: conditions	o						**
1000h / 1y	Telescopic boom: bearings and pivot bushes	o						**
1000h / 1y	Wear pads: wear	o						**

Maintenance								
1000h / 1y	Cab structure	o						**
1000h / 1y	Brakes oil circuit				o			**
1000h / 1y	Brakes oil circuit: Pressure	o						**
1000h / 1y	Brake			o				**
1000h / 1y	Electrical system: cables condition	o						**
1000h / 1y	Electrical system: Lighting and signaling	o						**
1000h / 1y	Electrical system: Acoustic signal devices	o						**
1000h / 1y	Hydraulic system: Jacks	o						**
1000h / 1y	Hydraulic system: Pipes and flexible pipes	o						**
1000h / 1y	Hydraulic system: Movements speed	o						**
1000h / 1y	Hydraulic oil					o		
1000h / 1y	Engine valves clearances	o						**
1000h / 1y	Coolant					o		
1000h / 1y	Engine speeds	o						**
1000h / 1y	Fuel tank				o			
1000h / 1y	Wheels and tires conditions	o						**
1000h / 1y	Chassis: bearings and pivot bushes	o						**
1000h / 1y	Chassis: structure	o						**
1000h / 1y	Transmission oil					o		
2000h	Axles oscillation	o						**
2000h	Ropes and chains (if installed)					o		**
2000h	Hydraulic system: Capacity	o						**
2000h	Hydraulic system: Pressures	o						**
2000h	Hydraulic oil tank				o			**
2000h	Alternator and Starter motor	o						**
2000h	Radiators	o			o			**
3600h	AdBlue tank filter FPT engine (only Stage IIIB/Tier 4i and Stage IV/Tier 4f engine sizes)					o		**
4000h	Prop shafts	o				o		**

Maintenance								
4000h	Reduction gears universal joint	o						**
4000h	Wheels reduction gear clearance	o						**
4000h	Steering ball joints	o						**
4000h	Wheels reduction gear pins	o						**
4000h	Brakes wear	o						**
2y	Air conditioning system (if installed): Dissipater filter					o		**
2y	Air conditioning system (if installed): Oil refrigerant	o						**
2y	Air conditioning system (if installed): Pressure switches	o		o				**
2y	Air conditioning system (if installed): Condenser and evaporator coils				o			**
2y	Air conditioning system (if installed): Condensate and exhaust valve tank				o			**

Notes	Stamp and signature

MAINTENANCE LOG			
Maintenance sheet no.	.....	Maintenance date	.....
Vehicle serial number:	.....	Maintenance technician name	.....
Vehicle hours	.....	Maintenance company name	.....

	Maintenance							
0h	Air conditioning system	<input type="checkbox"/>			<input type="checkbox"/>			
0h	Anti-tipping device inspection with load	<input type="checkbox"/>						
0h	Filters (air, engine oil, hydraulic oil, fuel, air conditioning system, cab)	<input type="checkbox"/>						
0h	Brake			<input type="checkbox"/>				
0h	Parking brake	<input type="checkbox"/>						
0h	Electrolyte level and battery charge	<input type="checkbox"/>						
0h	Lighting	<input type="checkbox"/>						
0h	Hydraulic oil level	<input type="checkbox"/>						
0h	Alternator belts \ services	<input type="checkbox"/>						
0h	Engine oil level	<input type="checkbox"/>						
0h	Radiators	<input type="checkbox"/>			<input type="checkbox"/>			
0h	Radiator expansion tank	<input type="checkbox"/>	<input type="checkbox"/>					
0h	Tires pressure	<input type="checkbox"/>						
0h	Wear check (on both the vehicle and equipment if installed)	<input type="checkbox"/>						
10h / 1m	Window washer tank	<input type="checkbox"/>	<input type="checkbox"/>					
10h / 1m	Boom chains (if installed)	<input type="checkbox"/>						
10h / 1m	Safety stickers	<input type="checkbox"/>						
10h / 1m	Safety devices	<input type="checkbox"/>						
10h / 1m	Coolant	<input type="checkbox"/>						
10h / 1m	Engine oil level	<input type="checkbox"/>						
10h / 1m	Metal structural work, no cracks	<input type="checkbox"/>						
10h / 1m	Radiators				<input type="checkbox"/>			
50h / 1m	Grease level in the automatic lubrication system (if installed)						<input type="checkbox"/>	
50h / 1m	Prop shafts						<input type="checkbox"/>	
50h / 1m	Axles oscillation						<input type="checkbox"/>	
50h / 1m	Wheels reduction gear pins						<input type="checkbox"/>	
50h / 1m	Ropes and chains (if installed)	<input type="checkbox"/>					<input type="checkbox"/>	
50h / 1m	Wear pads	<input type="checkbox"/>					<input type="checkbox"/>	
50h / 1m	Mechanical joints of parking brake on the axle						<input type="checkbox"/>	
50h / 1m	Mechanical joints						<input type="checkbox"/>	
50h / 1m	Cab ventilation filter				<input type="checkbox"/>			
50h / 1m	Brakes oil level	<input type="checkbox"/>						
50h / 1m	Hydraulic oil level	<input type="checkbox"/>						
50h / 1m	Hydraulic system leaks	<input type="checkbox"/>						
50h / 1m	Air filter				<input type="checkbox"/>			

	Maintenance							
50h / 1m	Fuel filter				o			
50h / 1m	Coolant	o						
50h / 1m	Engine oil level	o						
50h / 1m	Tires pressure	o						
50h / 1m	Wheel nuts tightening	o						
50h / 1m	Inching oil level (only PS transmissions)	o						
First 100h	Differential axle oil					o		
First 100h	Pump actuation return oil					o		
250h / 2m	Ropes and chains (if any) coupling points, wear and adjustment	o		o				o
250h / 2m	Boom chains (if installed)			o				
250h / 2m	Seat belts	o						
250h / 2m	Rear view mirrors	o						
250h / 2m	Anti-tipping device	o						
250h / 2m	Electrolyte level and battery charge	o						
250h / 2m	Torque specifications - Hydraulic Fittings			o				
250h / 2m	Alternator belts \ services	o		o				
250h / 2m	Torque specifications - fasteners			o				
500h / 6m	PTO gearbox oil (if installed)					o		
500h / 6m	Differential axle oil	o						
500h / 6m	Epicycloidal reduction gear oil	o						
500h / 6m	Forks: wear	o						
500h / 6m	Cab ventilation filter					o		
500h / 6m	Brakes oil					o		
500h / 6m	Electrical system	o						
500h / 6m	Hydraulic oil filter(s)					o		
500h / 6m	Block valves	o						
500h / 6m	Air filter					o		
500h / 6m	FPT fuel filter					o		
500h / 6m	FPT engine oil filter					o		
500h / 6m	FPT engine oil					o		
500h / 6m	KUBOTA fuel filter					o		
500h / 6m	KUBOTA engine oil filter					o		
500h / 6m	KUBOTA engine oil					o		
500h / 6m	Transmission oil	o						
500h / 6m	Pump actuation return oil					o		
1000h / 1y	PTO gearbox oil (if installed)					o		
1000h / 1y	Differential axle oil					o		
1000h / 1y	Epicycloidal reduction gear oil					o		
1000h / 1y	Equipment condition	o						**
1000h / 1y	Forks support plate: wear	o						**
1000h / 1y	Telescopic boom: conditions	o						**
1000h / 1y	Telescopic boom: bearings and pivot bushes	o						**
1000h / 1y	Wear pads: wear	o						**







Maintenance								
1000h / 1y	Cab structure	o						**
1000h / 1y	Brakes oil circuit				o			**
1000h / 1y	Brakes oil circuit: Pressure	o						**
1000h / 1y	Brake			o				**
1000h / 1y	Electrical system: cables condition	o						**
1000h / 1y	Electrical system: Lighting and signaling	o						**
1000h / 1y	Electrical system: Acoustic signal devices	o						**
1000h / 1y	Hydraulic system: Jacks	o						**
1000h / 1y	Hydraulic system: Pipes and flexible pipes	o						**
1000h / 1y	Hydraulic system: Movements speed	o						**
1000h / 1y	Hydraulic oil					o		
1000h / 1y	Engine valves clearances	o						**
1000h / 1y	Coolant					o		
1000h / 1y	Engine speeds	o						**
1000h / 1y	Fuel tank				o			
1000h / 1y	Wheels and tires conditions	o						**
1000h / 1y	Chassis: bearings and pivot bushes	o						**
1000h / 1y	Chassis: structure	o						**
1000h / 1y	Transmission oil					o		
2000h	Axles oscillation	o						**
2000h	Ropes and chains (if installed)					o		**
2000h	Hydraulic system: Capacity	o						**
2000h	Hydraulic system: Pressures	o						**
2000h	Hydraulic oil tank				o			**
2000h	Alternator and Starter motor	o						**
2000h	Radiators	o			o			**
3600h	AdBlue tank filter FPT engine (only Stage IIIB/Tier 4i and Stage IV/Tier 4f engine sizes)					o		**
4000h	Prop shafts	o				o		**







Maintenance								
4000h	Reduction gears universal joint	o						**
4000h	Wheels reduction gear clearance	o						**
4000h	Steering ball joints	o						**
4000h	Wheels reduction gear pins	o						**
4000h	Brakes wear	o						**
2y	Air conditioning system (if installed): Dissipater filter					o		**
2y	Air conditioning system (if installed): Oil refrigerant	o						**
2y	Air conditioning system (if installed): Pressure switches	o		o				**
2y	Air conditioning system (if installed): Condenser and evaporator coils				o			**
2y	Air conditioning system (if installed): Condensate and exhaust valve tank				o			**

Notes	Stamp and signature



MAINTENANCE LOG			
Maintenance sheet no.	.....	Maintenance date	.....
Vehicle serial number:	.....	Maintenance technician name	.....
Vehicle hours	.....	Maintenance company name	.....

	Maintenance							
0h	Air conditioning system	<input type="checkbox"/>			<input type="checkbox"/>			
0h	Anti-tipping device inspection with load	<input type="checkbox"/>						
0h	Filters (air, engine oil, hydraulic oil, fuel, air conditioning system, cab)	<input type="checkbox"/>						
0h	Brake			<input type="checkbox"/>				
0h	Parking brake	<input type="checkbox"/>						
0h	Electrolyte level and battery charge	<input type="checkbox"/>						
0h	Lighting	<input type="checkbox"/>						
0h	Hydraulic oil level	<input type="checkbox"/>						
0h	Alternator belts \ services	<input type="checkbox"/>						
0h	Engine oil level	<input type="checkbox"/>						
0h	Radiators	<input type="checkbox"/>			<input type="checkbox"/>			
0h	Radiator expansion tank	<input type="checkbox"/>	<input type="checkbox"/>					
0h	Tires pressure	<input type="checkbox"/>						
0h	Wear check (on both the vehicle and equipment if installed)	<input type="checkbox"/>						
10h / 1m	Window washer tank	<input type="checkbox"/>	<input type="checkbox"/>					
10h / 1m	Boom chains (if installed)	<input type="checkbox"/>						
10h / 1m	Safety stickers	<input type="checkbox"/>						
10h / 1m	Safety devices	<input type="checkbox"/>						
10h / 1m	Coolant	<input type="checkbox"/>						
10h / 1m	Engine oil level	<input type="checkbox"/>						
10h / 1m	Metal structural work, no cracks	<input type="checkbox"/>						
10h / 1m	Radiators				<input type="checkbox"/>			
50h / 1m	Grease level in the automatic lubrication system (if installed)						<input type="checkbox"/>	
50h / 1m	Prop shafts						<input type="checkbox"/>	
50h / 1m	Axles oscillation						<input type="checkbox"/>	
50h / 1m	Wheels reduction gear pins						<input type="checkbox"/>	
50h / 1m	Ropes and chains (if installed)	<input type="checkbox"/>					<input type="checkbox"/>	
50h / 1m	Wear pads	<input type="checkbox"/>					<input type="checkbox"/>	
50h / 1m	Mechanical joints of parking brake on the axle						<input type="checkbox"/>	
50h / 1m	Mechanical joints						<input type="checkbox"/>	
50h / 1m	Cab ventilation filter				<input type="checkbox"/>			
50h / 1m	Brakes oil level	<input type="checkbox"/>						
50h / 1m	Hydraulic oil level	<input type="checkbox"/>						
50h / 1m	Hydraulic system leaks	<input type="checkbox"/>						
50h / 1m	Air filter				<input type="checkbox"/>			







	Maintenance							
50h / 1m	Fuel filter				o			
50h / 1m	Coolant	o						
50h / 1m	Engine oil level	o						
50h / 1m	Tires pressure	o						
50h / 1m	Wheel nuts tightening	o						
50h / 1m	Inching oil level (only PS transmissions)	o						
First 100h	Differential axle oil					o		
First 100h	Pump actuation return oil					o		
250h / 2m	Ropes and chains (if any) coupling points, wear and adjustment	o		o				o
250h / 2m	Boom chains (if installed)			o				
250h / 2m	Seat belts	o						
250h / 2m	Rear view mirrors	o						
250h / 2m	Anti-tipping device	o						
250h / 2m	Electrolyte level and battery charge	o						
250h / 2m	Torque specifications - Hydraulic Fittings			o				
250h / 2m	Alternator belts \ services	o		o				
250h / 2m	Torque specifications - fasteners			o				
500h / 6m	PTO gearbox oil (if installed)					o		
500h / 6m	Differential axle oil	o						
500h / 6m	Epicycloidal reduction gear oil	o						
500h / 6m	Forks: wear	o						
500h / 6m	Cab ventilation filter					o		
500h / 6m	Brakes oil					o		
500h / 6m	Electrical system	o						
500h / 6m	Hydraulic oil filter(s)					o		
500h / 6m	Block valves	o						
500h / 6m	Air filter					o		
500h / 6m	FPT fuel filter					o		
500h / 6m	FPT engine oil filter					o		
500h / 6m	FPT engine oil					o		
500h / 6m	KUBOTA fuel filter					o		
500h / 6m	KUBOTA engine oil filter					o		
500h / 6m	KUBOTA engine oil					o		
500h / 6m	Transmission oil	o						
500h / 6m	Pump actuation return oil					o		
1000h / 1y	PTO gearbox oil (if installed)					o		
1000h / 1y	Differential axle oil					o		
1000h / 1y	Epicycloidal reduction gear oil					o		
1000h / 1y	Equipment condition	o						**
1000h / 1y	Forks support plate: wear	o						**
1000h / 1y	Telescopic boom: conditions	o						**
1000h / 1y	Telescopic boom: bearings and pivot bushes	o						**
1000h / 1y	Wear pads: wear	o						**

	Maintenance							
1000h / 1y	Cab structure	o						**
1000h / 1y	Brakes oil circuit				o			**
1000h / 1y	Brakes oil circuit: Pressure	o						**
1000h / 1y	Brake			o				**
1000h / 1y	Electrical system: cables condition	o						**
1000h / 1y	Electrical system: Lighting and signaling	o						**
1000h / 1y	Electrical system: Acoustic signal devices	o						**
1000h / 1y	Hydraulic system: Jacks	o						**
1000h / 1y	Hydraulic system: Pipes and flexible pipes	o						**
1000h / 1y	Hydraulic system: Movements speed	o						**
1000h / 1y	Hydraulic oil					o		
1000h / 1y	Engine valves clearances	o						**
1000h / 1y	Coolant					o		
1000h / 1y	Engine speeds	o						**
1000h / 1y	Fuel tank				o			
1000h / 1y	Wheels and tires conditions	o						**
1000h / 1y	Chassis: bearings and pivot bushes	o						**
1000h / 1y	Chassis: structure	o						**
1000h / 1y	Transmission oil					o		
2000h	Axles oscillation	o						**
2000h	Ropes and chains (if installed)					o		**
2000h	Hydraulic system: Capacity	o						**
2000h	Hydraulic system: Pressures	o						**
2000h	Hydraulic oil tank				o			**
2000h	Alternator and Starter motor	o						**
2000h	Radiators	o			o			**
3600h	AdBlue tank filter FPT engine (only Stage IIIB/Tier 4i and Stage IV/Tier 4f engine sizes)					o		**
4000h	Prop shafts	o				o		**

Maintenance								
4000h	Reduction gears universal joint	o						**
4000h	Wheels reduction gear clearance	o						**
4000h	Steering ball joints	o						**
4000h	Wheels reduction gear pins	o						**
4000h	Brakes wear	o						**
2y	Air conditioning system (if installed): Dissipater filter					o		**
2y	Air conditioning system (if installed): Oil refrigerant	o						**
2y	Air conditioning system (if installed): Pressure switches	o		o				**
2y	Air conditioning system (if installed): Condenser and evaporator coils				o			**
2y	Air conditioning system (if installed): Condensate and exhaust valve tank				o			**

Notes	Stamp and signature

MAINTENANCE LOG			
Maintenance sheet no.	.....	Maintenance date	.....
Vehicle serial number:	.....	Maintenance technician name	.....
Vehicle hours	.....	Maintenance company name	.....

	Maintenance							
0h	Air conditioning system	<input type="checkbox"/>			<input type="checkbox"/>			
0h	Anti-tipping device inspection with load	<input type="checkbox"/>						
0h	Filters (air, engine oil, hydraulic oil, fuel, air conditioning system, cab)	<input type="checkbox"/>						
0h	Brake			<input type="checkbox"/>				
0h	Parking brake	<input type="checkbox"/>						
0h	Electrolyte level and battery charge	<input type="checkbox"/>						
0h	Lighting	<input type="checkbox"/>						
0h	Hydraulic oil level	<input type="checkbox"/>						
0h	Alternator belts \ services	<input type="checkbox"/>						
0h	Engine oil level	<input type="checkbox"/>						
0h	Radiators	<input type="checkbox"/>			<input type="checkbox"/>			
0h	Radiator expansion tank	<input type="checkbox"/>	<input type="checkbox"/>					
0h	Tires pressure	<input type="checkbox"/>						
0h	Wear check (on both the vehicle and equipment if installed)	<input type="checkbox"/>						
10h / 1m	Window washer tank	<input type="checkbox"/>	<input type="checkbox"/>					
10h / 1m	Boom chains (if installed)	<input type="checkbox"/>						
10h / 1m	Safety stickers	<input type="checkbox"/>						
10h / 1m	Safety devices	<input type="checkbox"/>						
10h / 1m	Coolant	<input type="checkbox"/>						
10h / 1m	Engine oil level	<input type="checkbox"/>						
10h / 1m	Metal structural work, no cracks	<input type="checkbox"/>						
10h / 1m	Radiators				<input type="checkbox"/>			
50h / 1m	Grease level in the automatic lubrication system (if installed)						<input type="checkbox"/>	
50h / 1m	Prop shafts						<input type="checkbox"/>	
50h / 1m	Axles oscillation						<input type="checkbox"/>	
50h / 1m	Wheels reduction gear pins						<input type="checkbox"/>	
50h / 1m	Ropes and chains (if installed)	<input type="checkbox"/>					<input type="checkbox"/>	
50h / 1m	Wear pads	<input type="checkbox"/>					<input type="checkbox"/>	
50h / 1m	Mechanical joints of parking brake on the axle						<input type="checkbox"/>	
50h / 1m	Mechanical joints						<input type="checkbox"/>	
50h / 1m	Cab ventilation filter				<input type="checkbox"/>			
50h / 1m	Brakes oil level	<input type="checkbox"/>						
50h / 1m	Hydraulic oil level	<input type="checkbox"/>						
50h / 1m	Hydraulic system leaks	<input type="checkbox"/>						
50h / 1m	Air filter				<input type="checkbox"/>			

	Maintenance							
50h / 1m	Fuel filter				o			
50h / 1m	Coolant	o						
50h / 1m	Engine oil level	o						
50h / 1m	Tires pressure	o						
50h / 1m	Wheel nuts tightening	o						
50h / 1m	Inching oil level (only PS transmissions)	o						
First 100h	Differential axle oil					o		
First 100h	Pump actuation return oil					o		
250h / 2m	Ropes and chains (if any) coupling points, wear and adjustment	o		o				o
250h / 2m	Boom chains (if installed)			o				
250h / 2m	Seat belts	o						
250h / 2m	Rear view mirrors	o						
250h / 2m	Anti-tipping device	o						
250h / 2m	Electrolyte level and battery charge	o						
250h / 2m	Torque specifications - Hydraulic Fittings			o				
250h / 2m	Alternator belts \ services	o		o				
250h / 2m	Torque specifications - fasteners			o				
500h / 6m	PTO gearbox oil (if installed)					o		
500h / 6m	Differential axle oil	o						
500h / 6m	Epicycloidal reduction gear oil	o						
500h / 6m	Forks: wear	o						
500h / 6m	Cab ventilation filter					o		
500h / 6m	Brakes oil					o		
500h / 6m	Electrical system	o						
500h / 6m	Hydraulic oil filter(s)					o		
500h / 6m	Block valves	o						
500h / 6m	Air filter					o		
500h / 6m	FPT fuel filter					o		
500h / 6m	FPT engine oil filter					o		
500h / 6m	FPT engine oil					o		
500h / 6m	KUBOTA fuel filter					o		
500h / 6m	KUBOTA engine oil filter					o		
500h / 6m	KUBOTA engine oil					o		
500h / 6m	Transmission oil	o						
500h / 6m	Pump actuation return oil					o		
1000h / 1y	PTO gearbox oil (if installed)					o		
1000h / 1y	Differential axle oil					o		
1000h / 1y	Epicycloidal reduction gear oil					o		
1000h / 1y	Equipment condition	o						**
1000h / 1y	Forks support plate: wear	o						**
1000h / 1y	Telescopic boom: conditions	o						**
1000h / 1y	Telescopic boom: bearings and pivot bushes	o						**
1000h / 1y	Wear pads: wear	o						**







Maintenance								
1000h / 1y	Cab structure	o						**
1000h / 1y	Brakes oil circuit				o			**
1000h / 1y	Brakes oil circuit: Pressure	o						**
1000h / 1y	Brake			o				**
1000h / 1y	Electrical system: cables condition	o						**
1000h / 1y	Electrical system: Lighting and signaling	o						**
1000h / 1y	Electrical system: Acoustic signal devices	o						**
1000h / 1y	Hydraulic system: Jacks	o						**
1000h / 1y	Hydraulic system: Pipes and flexible pipes	o						**
1000h / 1y	Hydraulic system: Movements speed	o						**
1000h / 1y	Hydraulic oil					o		
1000h / 1y	Engine valves clearances	o						**
1000h / 1y	Coolant					o		
1000h / 1y	Engine speeds	o						**
1000h / 1y	Fuel tank				o			
1000h / 1y	Wheels and tires conditions	o						**
1000h / 1y	Chassis: bearings and pivot bushes	o						**
1000h / 1y	Chassis: structure	o						**
1000h / 1y	Transmission oil					o		
2000h	Axles oscillation	o						**
2000h	Ropes and chains (if installed)					o		**
2000h	Hydraulic system: Capacity	o						**
2000h	Hydraulic system: Pressures	o						**
2000h	Hydraulic oil tank				o			**
2000h	Alternator and Starter motor	o						**
2000h	Radiators	o			o			**
3600h	AdBlue tank filter FPT engine (only Stage IIIB/Tier 4i and Stage IV/Tier 4f engine sizes)					o		**
4000h	Prop shafts	o				o		**

Maintenance								
4000h	Reduction gears universal joint	o						**
4000h	Wheels reduction gear clearance	o						**
4000h	Steering ball joints	o						**
4000h	Wheels reduction gear pins	o						**
4000h	Brakes wear	o						**
2y	Air conditioning system (if installed): Dissipater filter					o		**
2y	Air conditioning system (if installed): Oil refrigerant	o						**
2y	Air conditioning system (if installed): Pressure switches	o		o				**
2y	Air conditioning system (if installed): Condenser and evaporator coils				o			**
2y	Air conditioning system (if installed): Condensate and exhaust valve tank				o			**

Notes	Stamp and signature



MAINTENANCE LOG			
Maintenance sheet no.	.....	Maintenance date	.....
Vehicle serial number:	.....	Maintenance technician name	.....
Vehicle hours	.....	Maintenance company name	.....

	Maintenance							
0h	Air conditioning system	<input type="checkbox"/>			<input type="checkbox"/>			
0h	Anti-tipping device inspection with load	<input type="checkbox"/>						
0h	Filters (air, engine oil, hydraulic oil, fuel, air conditioning system, cab)	<input type="checkbox"/>						
0h	Brake			<input type="checkbox"/>				
0h	Parking brake	<input type="checkbox"/>						
0h	Electrolyte level and battery charge	<input type="checkbox"/>						
0h	Lighting	<input type="checkbox"/>						
0h	Hydraulic oil level	<input type="checkbox"/>						
0h	Alternator belts \ services	<input type="checkbox"/>						
0h	Engine oil level	<input type="checkbox"/>						
0h	Radiators	<input type="checkbox"/>			<input type="checkbox"/>			
0h	Radiator expansion tank	<input type="checkbox"/>	<input type="checkbox"/>					
0h	Tires pressure	<input type="checkbox"/>						
0h	Wear check (on both the vehicle and equipment if installed)	<input type="checkbox"/>						
10h / 1m	Window washer tank	<input type="checkbox"/>	<input type="checkbox"/>					
10h / 1m	Boom chains (if installed)	<input type="checkbox"/>						
10h / 1m	Safety stickers	<input type="checkbox"/>						
10h / 1m	Safety devices	<input type="checkbox"/>						
10h / 1m	Coolant	<input type="checkbox"/>						
10h / 1m	Engine oil level	<input type="checkbox"/>						
10h / 1m	Metal structural work, no cracks	<input type="checkbox"/>						
10h / 1m	Radiators				<input type="checkbox"/>			
50h / 1m	Grease level in the automatic lubrication system (if installed)						<input type="checkbox"/>	
50h / 1m	Prop shafts						<input type="checkbox"/>	
50h / 1m	Axles oscillation						<input type="checkbox"/>	
50h / 1m	Wheels reduction gear pins						<input type="checkbox"/>	
50h / 1m	Ropes and chains (if installed)	<input type="checkbox"/>					<input type="checkbox"/>	
50h / 1m	Wear pads	<input type="checkbox"/>					<input type="checkbox"/>	
50h / 1m	Mechanical joints of parking brake on the axle						<input type="checkbox"/>	
50h / 1m	Mechanical joints						<input type="checkbox"/>	
50h / 1m	Cab ventilation filter				<input type="checkbox"/>			
50h / 1m	Brakes oil level	<input type="checkbox"/>						
50h / 1m	Hydraulic oil level	<input type="checkbox"/>						
50h / 1m	Hydraulic system leaks	<input type="checkbox"/>						
50h / 1m	Air filter				<input type="checkbox"/>			

	Maintenance							
50h / 1m	Fuel filter				o			
50h / 1m	Coolant	o						
50h / 1m	Engine oil level	o						
50h / 1m	Tires pressure	o						
50h / 1m	Wheel nuts tightening	o						
50h / 1m	Inching oil level (only PS transmissions)	o						
First 100h	Differential axle oil					o		
First 100h	Pump actuation return oil					o		
250h / 2m	Ropes and chains (if any) coupling points, wear and adjustment	o		o				o
250h / 2m	Boom chains (if installed)			o				
250h / 2m	Seat belts	o						
250h / 2m	Rear view mirrors	o						
250h / 2m	Anti-tipping device	o						
250h / 2m	Electrolyte level and battery charge	o						
250h / 2m	Torque specifications - Hydraulic Fittings			o				
250h / 2m	Alternator belts \ services	o		o				
250h / 2m	Torque specifications - fasteners			o				
500h / 6m	PTO gearbox oil (if installed)					o		
500h / 6m	Differential axle oil	o						
500h / 6m	Epicycloidal reduction gear oil	o						
500h / 6m	Forks: wear	o						
500h / 6m	Cab ventilation filter					o		
500h / 6m	Brakes oil					o		
500h / 6m	Electrical system	o						
500h / 6m	Hydraulic oil filter(s)					o		
500h / 6m	Block valves	o						
500h / 6m	Air filter					o		
500h / 6m	FPT fuel filter					o		
500h / 6m	FPT engine oil filter					o		
500h / 6m	FPT engine oil					o		
500h / 6m	KUBOTA fuel filter					o		
500h / 6m	KUBOTA engine oil filter					o		
500h / 6m	KUBOTA engine oil					o		
500h / 6m	Transmission oil	o						
500h / 6m	Pump actuation return oil					o		
1000h / 1y	PTO gearbox oil (if installed)					o		
1000h / 1y	Differential axle oil					o		
1000h / 1y	Epicycloidal reduction gear oil					o		
1000h / 1y	Equipment condition	o						**
1000h / 1y	Forks support plate: wear	o						**
1000h / 1y	Telescopic boom: conditions	o						**
1000h / 1y	Telescopic boom: bearings and pivot bushes	o						**
1000h / 1y	Wear pads: wear	o						**

Maintenance								
1000h / 1y	Cab structure	o						**
1000h / 1y	Brakes oil circuit				o			**
1000h / 1y	Brakes oil circuit: Pressure	o						**
1000h / 1y	Brake			o				**
1000h / 1y	Electrical system: cables condition	o						**
1000h / 1y	Electrical system: Lighting and signaling	o						**
1000h / 1y	Electrical system: Acoustic signal devices	o						**
1000h / 1y	Hydraulic system: Jacks	o						**
1000h / 1y	Hydraulic system: Pipes and flexible pipes	o						**
1000h / 1y	Hydraulic system: Movements speed	o						**
1000h / 1y	Hydraulic oil					o		
1000h / 1y	Engine valves clearances	o						**
1000h / 1y	Coolant					o		
1000h / 1y	Engine speeds	o						**
1000h / 1y	Fuel tank				o			
1000h / 1y	Wheels and tires conditions	o						**
1000h / 1y	Chassis: bearings and pivot bushes	o						**
1000h / 1y	Chassis: structure	o						**
1000h / 1y	Transmission oil					o		
2000h	Axles oscillation	o						**
2000h	Ropes and chains (if installed)					o		**
2000h	Hydraulic system: Capacity	o						**
2000h	Hydraulic system: Pressures	o						**
2000h	Hydraulic oil tank				o			**
2000h	Alternator and Starter motor	o						**
2000h	Radiators	o			o			**
3600h	AdBlue tank filter FPT engine (only Stage IIIB/Tier 4i and Stage IV/Tier 4f engine sizes)					o		**
4000h	Prop shafts	o				o		**

Maintenance								
4000h	Reduction gears universal joint	o						**
4000h	Wheels reduction gear clearance	o						**
4000h	Steering ball joints	o						**
4000h	Wheels reduction gear pins	o						**
4000h	Brakes wear	o						**
2y	Air conditioning system (if installed): Dissipater filter					o		**
2y	Air conditioning system (if installed): Oil refrigerant	o						**
2y	Air conditioning system (if installed): Pressure switches	o		o				**
2y	Air conditioning system (if installed): Condenser and evaporator coils				o			**
2y	Air conditioning system (if installed): Condensate and exhaust valve tank				o			**

Notes	Stamp and signature





---