



DIECI

USE AND MAINTENANCE MANUAL

SAMSON - AGRI MAX GD

Stage V



DIECI S.r.l. Via E. Majorana, 2-4
42027 Montecchio Emilia (RE) ITALY
Tel. +39 0522 869611 Fax +39 0522 869791
www.dieci.com - e-mail: info@dieci.com

ATTENTION:

A copy of the following manual must always be available to the operator on the vehicle.

USE AND MAINTENANCE MANUAL

Issued by	Document code	Issue date	Review date	Prepared by
Technical Documentation	DOCMA00000108 – Rev. 09	09/2020	07/2022	Technical Documentation

Original instructions for:

	Vehicle model	Brand	Emission standard	Nominal power	Homologation	Area	Sector
MFO3518	SAMSON 75.10 - GD	FPT	Stage V	103 kW (138 HP)	-	EC	CONSTRUCTION
MFO3517	AGRI MAX 75.10 - GD	FPT	Stage V	103 kW (138 HP)	-	EC	AGRICULTURAL

Standards

This manual is prepared in Italian in accordance with the provisions indicated in the following Standards:

- EN1459-1
- ISO 3600:2015
- ISO 6750:2005
- M.D. 2006/42/EC

Dear Customer,

congratulations and thank you for choosing **DIECI**.

This Use and Maintenance Manual has been written to help you fully appreciate the quality of **DIECI** products.

We strongly recommend that you read this manual in its entirety before using the vehicle.

It contains information, advice and important warnings that will help you to fully take advantage of the technical capabilities of your **DIECI** products.

You will learn about its features and special practical information in addition to information about its maintenance, driver and operation safety to help maintain your **DIECI** products over time.

We are confident that you will be happy with your new purchase and we remain at your disposal should you have any further queries.

Sincerely,

Sales Management



www.dieci.com

Dieci s.r.l.

VIA E. MAJORANA, 2-4

42027 - MONTECCHIO E. (RE) - ITALY

TEL. ++39 0522-869611

FAX ++39 0522-869744

e-mail: info@dieci.com

Fully paid-up share capital € 10.000.000,00

Companies Register R.E. No. 01283560686 - Economic and Administrative Index R.E. No. 204278

Tax Code 01283560686 - VAT no. 01682740350

1.1 - General information

Each vehicle is provided with:

- Copy of this manual
- A copy of the use and maintenance manual of the engine prepared by the manufacturer
- A copy of the use and maintenance manual for each device or equipment which is installed on this vehicle.

These manuals have been prepared by the respective suppliers and are faithfully reproduced in full by *DIECI S.R.L.* Behind their specific authorization: they can be enriched with additional specifications drawn up by *DIECI S.R.L.*



WARNING

All documentation provided is an integral and essential part of the product and must be kept at the disposal of the users; they must carefully read what is written in the above mentioned documentation before using it.



DANGER

Improper, incorrect or unreasonable use of the vehicle or accessory installed on it is not allowed as also any intervention that alters its structure or operation is not allowed.



NOTE

Reproduction of all or part of the contents of this manual and any multimedia attachment.

Dieci s.r.l. will protect the ownership rights of these materials.



ATTENTION

A copy of this manual must always be available to the operator on the vehicle.

This vehicle has been designed and built as a self-propelled vehicle with operator's seat, wheels, designed for use on paved or natural ground and on uneven ground.

It consists of a main support structure suitable to support the extensible boom.

The head of the boom can be fitted with forks or other equipment only if approved by *Dieci s.r.l.* or only if the manufacturer of the equipment declares that its use conforms with the type of vehicle.

When used normally, the vehicle performs loads lifting and positioning by extending/ retracting, lifting/ lowering the boom.



WARNING

Any other use is considered contrary to the intended use by *DIECI s.r.l.* which, therefore, can not be responsible for damage to objects and the vehicle itself, or injury to persons that might derive from misuse.

For other controls, or complaints to agencies, refer to the applicable local legislation in the country of use of the vehicle.

1.2 - Identification of the vehicle

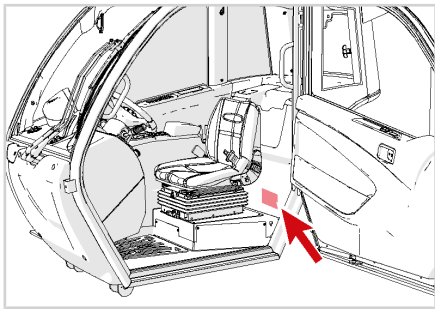

150640-1

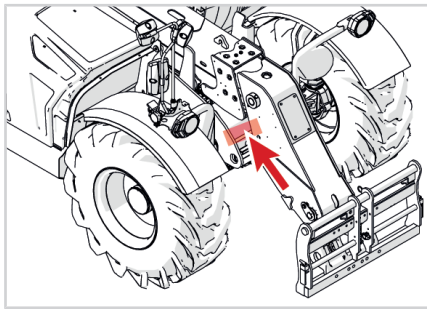

150640-2

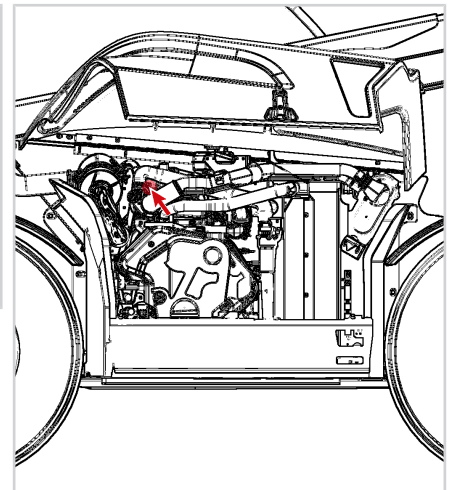

150640-3

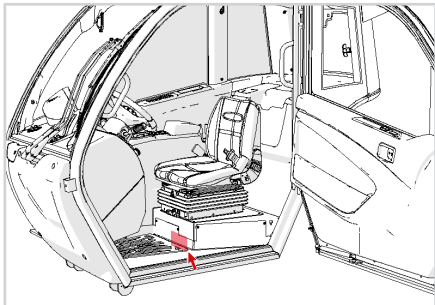

150640-4

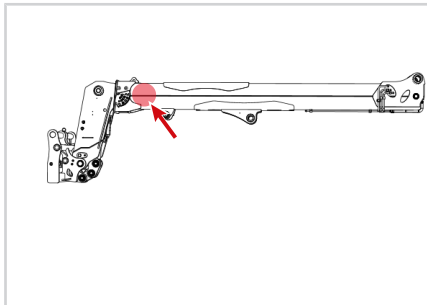

150640-5

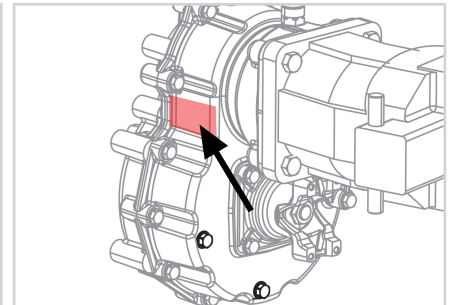

150640-6

Vehicle model (fig. 150640-1)
Serial number of the chassis (fig. 150640-2)
Serial number of the engine (fig. 150640-3)
Serial number of the cab (fig. 150640-4)
Serial number of the boom (fig. 150640-5)
Serial number of the transmission gearbox (fig. 150606)
Manufacturer
Manufacturer's Address
Vehicle model
Year of construction

Ground

Equipment code	Serial number	Year
.....
.....
.....
.....

Table of Contents

1	Info	3
1.1	General information.....	5
1.2	Identification of the vehicle	6
	Definitions	17
2	Introduction	18
2.1	Manual structure	18
2.2	Purpose and content	18
2.3	Preservation	18
2.4	Recipients	18
2.4.1	Training.....	18
2.4.2	Training.....	19
2.4.3	Qualification.....	19
2.5	Classification of dangers.....	19
2.6	Vehicle general warnings.....	20
2.7	Equipment general warnings.....	21
2.8	Intended use.....	21
2.9	Contraindications for use.....	21
2.10	Declaration of first test.....	21
2.11	Liability.....	21
2.12	Manufacturer	22
2.13	Vehicle identification label.....	22
2.14	Certification and CE marking.....	24
2.15	Units of measurement and abbreviations used.....	25
3	Warranty.....	27
3.1	Exclusions from the guarantee	27
3.2	Delivery and installation.....	27
3.3	Warranty: duration	27
3.4	Warranty: commencement.....	27
3.5	Warranty: activation.....	28
3.6	Warranty procedure.....	28
3.7	Intervention campaigns for faulty products	28
3.8	Warranty: intervention request.....	28
3.8.1	Guarantee: claim	28
3.8.2	Obligation of vehicle downtime.....	28
3.9	Non-activation, failure to grant, termination.....	28
3.9.1	Warranty: failure to grant	28
3.9.2	Guarantee: termination	29
3.10	Final terms	29
4	Safety regulations.....	30
4.1	General warnings.....	30
4.2	Safety indications.....	31
4.3	Personal protective equipment	32

4.3.1	Protective clothing	32
4.3.2	Protect yourself against noise	32
4.3.3	Protections against objects falling from height.....	33
4.3.4	Protect yourself from flying fragments.....	33
4.4	Preparing for accidents.....	33
4.4.1	First Aider Tasks	33
4.4.2	Emergency call.....	33
4.4.3	Traumas	34
4.4.4	Hemorrhages.....	34
4.5	Preventing fires and accidents.....	34
4.5.1	Risks of fires	34
4.5.2	Risks of inhaling gas	35
4.5.3	Risks of batteries exploding	35
4.5.4	Residual risks.....	35
4.5.5	Contact with dangerous substances	36
4.6	Storing dangerous liquids	36
4.7	Warnings for safe working.....	38
4.7.1	Ensuring the vehicle is clean.....	38
4.7.2	Checking for damage	38
4.7.3	Start working with the vehicle	38
4.7.4	Passengers transportation.....	38
4.7.5	Electrical system protection.....	38
4.7.6	Signals to multiple vehicles.....	40
4.7.7	Working with the danger of falling masses and objects	42
4.7.8	Working near electrical lines.....	42
4.7.9	Working under the snow.....	42
4.7.10	Working with scarce lighting.....	43
4.7.11	Working in closed areas or dangerous atmospheres.....	43
4.7.12	Reduce vibrations	44
4.8	Working in windy conditions.....	44
4.9	Assessing the consistency of the work ground.....	45
4.10	Moving safely	45
4.11	General warnings for moving the load	46
4.12	Use of cables, ropes and slings	47
4.13	Road travel.....	47
4.13.1	Road travel warnings	47
4.13.2	Road travel instructions.....	48
4.14	Momentary stop.....	48
4.15	Parking the vehicle	49
4.16	Starting and stopping the vehicle	49
4.16.1	General warnings regarding starting up the vehicle	49
4.16.2	Inspections prior to starting-up.....	49
4.16.3	Starting-up the engine.....	50
4.16.4	Warm-up after starting-up.....	51
4.16.5	Start-up at low environmental temperatures.....	51
4.16.6	Causes of failed start-ups	51
4.16.7	Turn off the vehicle.....	52
5	Vehicle description	53
5.1	Left side components description	54
5.2	Right side components description	55
5.3	Engine components description	56
5.4	Cab description.....	57

6	Safety devices	59
6.1	List of safety devices	59
6.2	Safety stickers	60
6.2.1	Warnings for safety stickers.....	60
6.2.2	Meaning of safety stickers	61
6.2.3	Safety stickers position on the vehicle	64
6.2.4	Safety stickers position in the cab.....	66
7	Components description.....	67
7.1	ROPS - FOPS Cab	67
7.2	Climbing in and off the vehicle.....	67
7.2.1	Door opening	67
7.2.2	Climbing in/out.....	68
7.3	Safety.....	69
7.3.1	Emergency stop.....	69
7.3.2	Emergency stop lever.....	69
7.3.3	Safety rod.....	69
7.3.4	Wheel wedge.....	70
7.3.5	Block valves	70
7.3.6	Emergency exit: Rear glass	70
7.3.7	Emergency exit: Front glass *	71
7.4	Comfort.....	71
7.4.1	Heated mirrors *	71
7.4.2	Electric window	71
7.4.3	Canopy.....	72
7.4.4	Sunshade.....	72
7.4.5	Rear glass	72
7.4.6	Storage compartment.....	72
7.4.7	Armrest	73
7.4.8	USB ports*.....	73
7.4.9	Interior mirror.....	73
7.4.10	Mirror adjustment *	73
7.5	Lighting	74
7.5.1	Emergency Lights	74
7.5.2	Sidelights and low beam lights.....	74
7.5.3	High beam lights.....	74
7.5.4	Direction indicators.....	75
7.5.5	Rotating light.....	75
7.5.6	Cab front light *	75
7.5.7	Cab rear light *	76
7.5.8	Work light on the boom head*	76
7.5.9	Perimeter lights *	76
7.6	Seat.....	76
7.6.1	Deadman seat sensor	77
7.6.2	Seat adjustment	77
7.6.3	Seat belts.....	78
7.7	Windows.....	79
7.7.1	Front window wiper.....	79
7.7.2	Window washer	79
7.7.3	Upper and rear window wiper and washer	80
7.7.4	Window wiper-washer on boom side *	80
7.7.5	Wiper fluid tank	80
7.8	Instrument panel.....	81
7.8.1	Components	81
7.8.2	Initial loading.....	83

7.8.3	Display.....	83
7.8.4	Equipment capacity *	83
7.8.5	General alarm icon and/or boom absolute angle.....	84
7.8.6	Service.....	84
7.8.7	Clock.....	85
7.8.8	Hour meter.....	85
7.8.9	Transmission Icon.....	85
7.8.10	Outriggers icon *	86
7.8.11	Low Idle UP icon.....	86
7.8.12	Anti-tipping device ByPass icon.....	86
7.8.13	Seat Switch icon.....	86
7.8.14	Wheels alignment check icon *	86
7.8.15	Not connected man basket icon *	86
7.8.16	Boom Chains Error icon *	87
7.8.17	Levelness Icon *	87
7.8.18	Hydraulic sockets on boom head icon *	87
7.8.19	Pop-up for accumulation of unburned hydrocarbons (HCs) *	87
7.8.20	FPT Stage V AdBlue quantity.....	88
7.8.21	Menu.....	88
7.8.22	Info page.....	88
7.8.23	Active errors.....	89
7.8.24	Check page.....	89
7.8.25	Equipment Info page *	89
7.9	Anti-tipping device.....	90
7.9.1	ByPass key.....	91
7.9.2	Longitudinal momentum indicator.....	91
7.9.3	Operation check with anti-tipping device load.....	92
7.10	Guide and Transmission.....	93
7.10.1	FNR commands on joystick.....	93
7.10.2	Movement selection lever FNR*	94
7.10.3	Maximum speed limitation.....	95
7.10.4	Mechanical transmission.....	95
7.10.5	Steering wheel.....	96
7.10.6	Horn.....	96
7.10.7	Steering selector lever.....	97
7.10.8	Wheels alignment check *	98
7.10.9	Parking brake.....	98
7.10.10	Service braking pedal.....	100
7.10.11	Inching Pedal.....	100
7.10.12	Accelerator pedal.....	100
7.10.13	CREEP mode.....	101
7.11	Diagrams notebook.....	101
7.11.1	Load Charts.....	101
7.12	Boom control.....	105
7.12.1	Joystick.....	105
7.12.2	Boom suspension *	108
7.12.3	Quick coupling *	109
7.13	Ventilation.....	110
7.13.1	Ventilation adjustment.....	110
7.13.2	Air temperature adjustment.....	110
7.13.3	Air conditioning *	110
7.13.4	Ventilation nozzles.....	110
7.14	Levelling.....	111
7.14.1	Spirit Level.....	111
7.14.2	Transverse levelling *	111
7.15	Outriggers *	111

7.15.1	Outriggers warnings	111
7.15.2	Outriggers movement.....	112
7.16	Optional attachments	112
7.16.1	Fan reversal *	112
7.16.2	Pressure relief from hydraulic sockets *	113
7.16.3	Rear hydraulic sockets *	113
7.17	Remote Control *	115
7.17.1	Remote control with levers: Description	115
7.17.2	Remote control with joystick: Description.....	120
7.17.3	Remote Control: Use	125
7.17.4	Remote Control: Turn off the vehicle and the remote control.....	126
7.17.5	Remote Control: Receiver	126
7.17.6	Remote Control: Recharge.....	126
7.17.7	Remote Control: Back-up	126
7.17.8	Remote Control: Additional information.....	126
7.18	Engine	127
7.18.1	AdBlue®	127
7.18.2	FPT Series N Stage V engine.....	129
8	DPF - Particulate filter regeneration	131
9	Description of agriculture components.....	132
9.1	Agricultural applications	132
9.2	Forest and forestry applications	132
9.3	Caisson descent *	132
9.4	Trailer descent **	133
9.5	Towing a trailer **	134
9.5.1	Warnings for towing a trailer.....	134
9.5.2	Towing a trailer on the road for AGRICULTURAL vehicles	134
9.5.3	Towing a trailer on the road for CONSTRUCTION vehicles	135
9.6	Trailer braking	135
9.6.1	Trailer braking system	135
9.6.2	Hydraulic braking MR type	137
9.6.3	Hydraulic braking type CUNA NC 344-05.....	138
9.7	Trailers electrical socket **	138
9.8	Hitches for rear trailers **	138
9.9	Height adjustable tow hitch adjustment **	139
9.10	Pick-up hitch **	140
10	Equipment.....	142
11	Equipment and tools	143
11.1	General warnings on equipment use	143
11.1.1	Equipment pre-use checks	144
11.1.2	Bucket warnings.....	145
11.2	Equipment installation procedure.....	146
11.3	Hydraulic connections	148
11.3.1	Warnings for hydraulic connections	148
11.3.2	Type of hydraulic quick couplings	148
11.3.3	References for correct connection.....	148
11.3.4	Push-Pull couplings connection.....	149
11.3.5	Flat-Face couplings connection.....	151
11.3.6	Closed centre distributor: Relieve the pressure through the trailer Descent button*.....	152
11.4	Electrical Connections.....	152

11.4.1	Warnings for electrical connections.....	152
11.4.2	Procedure for connecting electrical connections.....	153
11.5	Equipment removal.....	154
11.5.1	Electrical connections removal.....	154
11.5.2	Push-Pull couplings removal.....	155
11.5.3	Flat-Face couplings removal.....	156
11.6	Forks.....	157
11.6.1	Identification.....	157
11.6.2	Description.....	157
11.6.3	Forks check.....	158
11.6.4	Forks use.....	158
11.6.5	Forks adjustment.....	159
11.6.6	Fork block.....	159
11.6.7	Fork extensions.....	159
11.6.8	Forks safe working procedures.....	160
11.7	Bucket.....	163
11.7.1	Buckets identification.....	163
11.7.2	Buckets description.....	164
11.7.3	Buckets safety stickers.....	164
11.7.4	Bucket use.....	164
11.7.5	Fixed tilt indicator use.....	165
11.7.6	Movable tilt indicator use *.....	165
11.7.7	Buckets Safe Working Procedures.....	166
11.8	Equipment lifting.....	167
11.9	Equipment transport.....	167
12	Emergency procedure.....	169
12.1	Emergency procedure list.....	169
12.2	Vehicle towing.....	170
12.2.1	Vehicle towing with electrical panel on.....	170
12.2.2	Towing the vehicle with engine in failure.....	171
12.3	Man basket recovery in case of failure for fixed vehicles.....	171
12.3.1	Man basket recovery from cab.....	171
13	Boom raise in emergency.....	173
14	Maintenance.....	174
14.1	Maintenance warnings.....	174
14.1.1	Avoid accidents during maintenance.....	174
14.1.2	Personal protective equipment for maintenance.....	176
14.2	Summary of most frequent maintenance operations.....	177
14.3	Engine hood opening.....	177
14.4	Battery.....	178
14.4.1	Low maintenance batteries.....	178
14.4.2	"Zero" maintenance batteries.....	178
14.4.3	Battery: Instructions for recharging.....	178
14.4.4	Electrical battery isolator.....	179
14.4.5	Battery: Replacement.....	180
14.4.6	Start up with auxiliary batteries.....	180
14.5	Fuel.....	181
14.5.1	Specifications for recommended fuel.....	181
14.5.2	Cleaning and storing fuel.....	181
14.5.3	Refuelling.....	182
14.5.4	Fuel tank: Cleaning.....	182
14.6	Safety stickers: Inspection.....	182

14.7	Lubrication	182
14.7.1	Automatic lubrication system	183
14.8	Preliminary maintenance operations	187
14.8.1	Prepare the vehicle in the "Maintenance position"	187
14.9	Engine maintenance.....	188
14.9.1	Belts: Check and adjustment	188
14.9.2	Fuel filter: Replacement.....	188
14.9.3	Engine oil filter: Replacement.....	188
14.9.4	Engine oil: Check and filling up.....	188
14.10	Air filter: Cartridges cleaning and replacement.....	189
14.11	Radiator maintenance.....	190
14.11.1	Air recirculation grids and nets.....	190
14.11.2	Radiator: Checking and cleaning.....	190
14.11.3	Radiator: Liquid filling up and replacement.....	191
14.12	Hydraulic system maintenance	191
14.12.1	Hydraulic oil: Check and replacement.....	191
14.12.2	Hydraulic oil intake filter: Replacement.....	192
14.12.3	Hydraulic oil return filter	193
14.13	speed transmission maintenance.....	193
14.13.1	Oil change: Inspection.....	193
14.13.2	Oil change: Check and replacement	193
14.14	Brakes maintenance.....	194
14.14.1	Brake: Inspection	194
14.14.2	Brakes oil: Check and replacement.....	194
14.15	Wheel maintenance	194
14.15.1	Epicycloidal reduction gear oil: Check and replacement	194
14.15.2	Wheel nuts tightening	195
14.15.3	Tires.....	195
14.16	Lighting	197
14.16.1	Headlight	197
14.16.2	Tail light.....	198
14.16.3	Work light *	198
14.16.4	Led work light*.....	198
14.17	Window washer fluid tank.....	199
14.18	Ventilation system maintenance.....	199
14.18.1	Cab ventilation filter: Cleaning and replacement	199
14.18.2	Air conditioning: Cleaning *	200
14.19	Boom maintenance.....	200
14.19.1	Sliding blocks maintenance	200
14.19.2	Boom lubrication with grease	201
14.20	Cylinders block valves maintenance.....	201
14.21	Differential Axles Maintenance.....	203
14.21.1	Differential axles oil: Check and replacement	203
14.22	Hydraulic fittings tightening torques	204
14.23	Torque specifications - fasteners.....	205
14.23.1	Torque specifications - fasteners: Fine pitch.....	205
14.23.2	Torque specifications - fasteners: Coarse pitch.....	207
15	Technical assistance service.....	209
15.1	Spare parts supply	209
15.2	Assistance to owner / operator.....	209
15.3	Technical Assistance Service address.....	209

16 Problems diagnostics	210
16.1 Engine	210
16.2 Hydraulic transmission system	210
16.3 Brakes	211
16.4 Steering wheel	211
16.5 Telescopic boom	211
17 Error list	000
17.1 Anti-tipping device errors list	214
17.2 Braking circuit errors list	215
17.3 VCM errors	216
17.4 BCM errors	227
18 Cleaning	238
18.1 Vehicle cleaning	238
18.2 Glasses cleaning	238
18.3 Cleaning the cab	238
18.4 Safety stickers cleaning.....	238
19 Lifting the vehicle	239
20 Transporting the vehicle on a trailer	240
21 Storing the vehicle	241
21.1 Long period of inactivity	241
21.2 Long period of inactivity	241
21.3 Restarting the vehicle.....	241
22 WASTE DISPOSAL	242
22.1 Ecological considerations	242
22.2 Protect the environment.....	242
23 Demolition	243
24 Wiring diagram	244
24.1 Components legend	244
24.2 Wiring diagrams	252
25 Hydraulic diagram	269
25.1 Components legend	269
25.2 Hydraulic diagrams	271
26 Technical data	273
26.1 Dimensions.....	273
26.2 Performance	273
26.3 Engine	274
26.4 Weights.....	275
26.5 Electrical and hydraulic system.....	275
26.6 Transmission	275
26.7 Axles.....	275
26.8 Acoustic pressure.....	276

26.9 Acoustic power	276
26.10 Vibration.....	276
26.11 Filling	277
26.11.1 DIECI Hydro Telehandler Fluid ISO46	278
26.11.2 DIECI Hydro Telehandler Fluid ISO32	279
26.11.3 Declaration of conformity for F-Gas	280
26.12 SAMSON 75.10 - GD	281
26.12.1 Equipment	281
26.13 AGRI MAX 75.10 - GD	284
26.13.1 Equipment	284
26.14 Environmental conditions	287
26.15 Electromagnetic Interference.....	287
26.16 Radiations	287
26.17 Forks technical data	288
26.18 Buckets technical data	289
26.19 Tyre data.....	291
27 Load Charts.....	292
27.1 Diagrams Agri Max - Samson 75.10.....	294
28 Control and maintenance logs.....	297
28.1 Type of logs	297
28.1.1 Control log.....	297
28.1.2 Maintenance Log	297
28.2 Instructions for compiling the logs	297
28.2.1 Warnings on the control log	297
28.2.2 Warnings on the maintenance log	298
28.2.3 Logs compiling	298
28.2.4 Logs legend.....	299
28.2.5 Intervals legend	300
28.3 Periodic checks and recording mode (Italian only)	301
28.4 Obligation and how to report to I.N.A.I.L. (National institute for insurance against accidents at work) (Italy only)	301
28.5 Control log.....	302
28.6 Maintenance log	312

Definitions

Attachment holding plate

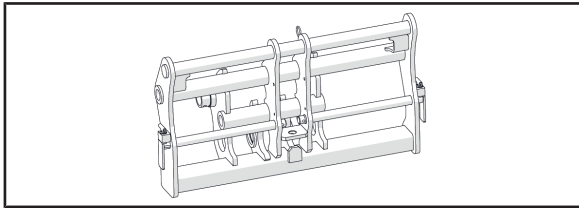

The attachment holding plate is the interface between the vehicle (telehandler) and the interchangeable equipment. The attachment holding plate is placed at the end of the telescopic boom and is used for the quick and safe installation of the interchangeable equipment at the vehicle base.

Back

The back is the side that is in back of the operator in the control position during the normal forward travel of the vehicle.

Equipment

The equipment is an interchangeable device that can be installed by the operator on the attachment holding plate of the vehicle, in order to change the function of the vehicle.

Front

The front is the side that is in front of the operator in the control position during the normal forward travel of the vehicle.

Generic maintenance technician

Trained and educated person to perform routine maintenance interventions with basic mechanical, electrical and hydraulic knowledge.

Left side

The left side is the side that is located to the left of the operator in the control position during the normal forward travel of the vehicle.

Operator

Instructed person, trained with specific theoretical-practical course concerning use of the vehicle or equipment.

Right side

The right side is the side that is located to the right of the operator in the control position during the normal forward travel of the vehicle.

Specialized maintenance technician

Trained and educated person to perform routine and extraordinary maintenance interventions with in-depth and specific mechanical, electrical and hydraulic knowledge, normally sent or authorized by DIECI s.r.l. or the dealer.

Tool

Category of interchangeable equipment not provided with movable parts such as forks or buckets. No CE marking is required for tools.

Vehicle

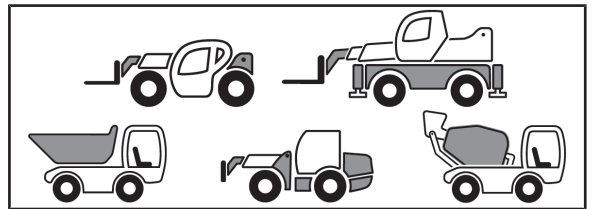

Vehicle means a work vehicle provided with an engine for operation. The term "vehicle" or "basic vehicle" are indistinctly used.

2.1 - Manual structure

This manual is an integral part of the official documentation of the Vehicle, Equipment and Tool. It must be carefully stored and be available to the managers, the users and personnel in charge of maintenance.

2.2 - Purpose and content

This manual is an integral part of the official documentation and is aimed at supplying the Operator with all the information required concerning technical aspects, operation and safety during the entire lifespan of the vehicle or equipment.



ATTENTION

This manual should be read carefully before the first use or before maintenance.



NOTE

If in doubt on the correct understanding of the instructions, contact the Manufacturer for clarifications.

2.3 - Preservation

The instruction manual must be kept near the equipment available to the Users (in the cab or on the equipment where set up) inside a dedicated envelope, protected from liquids and anything that might make it illegible.

If the manual becomes creased and/or be, even partially, damaged or illegible or in case of loss of the manual, it must be replaced immediately by contacting the **Dieci Technical Assistance Service**, giving the details of the manual found on the first page of the manual.

2.4 - Recipients

This manual is addressed to the following persons:

- Operator : instructed person, trained with specific theoretical-practical course concerning use of the vehicle or equipment
- Generic maintenance technician : trained and educated person to perform routine maintenance interventions with basic mechanical, electrical and hydraulic knowledge

- Specialized maintenance technician : trained and educated person to perform routine and extraordinary maintenance interventions with in-depth and specific mechanical, electrical and hydraulic knowledge, normally sent or authorized by **DIECI s.r.l.** or the dealer.



ATTENTION

The users must not carry out operations reserved for maintenance technicians or qualified technicians. The Manufacturer is not liable for damage deriving from the non-compliance with this prohibition.

2.4.1 - Training

This manual gives the users all technical data on the vehicle or on the equipment, the presence and type of control and safety devices and the presence and meaning of the safety stickers and plates.

All vehicle or equipment users must have all necessary information, training and education in relation to the correct use conditions of the means and foreseeable anomalous risks.

The information, training and educating must be implemented upon introduction of new work equipment and for each work equipment available to users.



NOTE

Ensure to respect the current laws and Standards in the selling country of the vehicle with regard to information, training and educating of personnel to use the vehicle and its equipment.

The employer is obliged to inform personnel on the following topics related to safety during use:

- Risk of injury
- Vehicle and equipment safety devices set up for operator safety
- Individual safety devices set up for operator safety
- General accident-prevention rules and/or foreseen by international directives
- Accident-prevention rules of Legislation of the Country where the vehicle or the equipment is intended for use

The operator, before starting the work, must know the characteristics of the vehicle and equipment and must have fully read this Use and Maintenance Manual.

2.4.2 - Training



ATTENTION

The operator in charge of using the vehicle or equipment must have attended a suitable theoretical-practical course lasting as long as indicated by legal prescriptions in the Country where the vehicle or equipment is used.

Training must at least include the following subjects:

- Use and limits of the operation and emergency controls of the equipment and of the vehicle on which the equipment is mounted
- Knowledge and awareness of the Use and Maintenance Manual and of the control marks, of the instructions and of the warnings applied on the vehicle
- Knowledge and understanding of the Standard on this equipment, including the educating aimed at recognizing and avoiding potential dangers at work
- Knowledge of the mechanical operation of the vehicle sufficient for recognizing a real or potential failure
- Hints on constructive particulars of the vehicles and on static and dynamic stability concepts
- Correct use of the vehicle procedures in safe conditions with regard to the work place and the load to be handled/lifted, capacity and guide notions
- Knowledge and use of the PPE to be worn during use of the vehicle and of the equipment
- Knowledge and execution of the routine maintenance to be carried out

Training must be carried out under the supervision of a qualified person in an open area and free from obstacles. At the end of this practice, the trainee must be able to safely use the equipment, and the vehicle on which it is installed.

The operator must also be trained on the responsibility and authority of not using the vehicle or equipment in case of failure or presence of unsafe conditions, and request further information from the Manufacturer or authorized dealer.

2.4.3 - Qualification

The vehicle and equipment are intended for professional use; their use must therefore be entrusted to qualified figures, in particular:

- Being of adult age
- Be physically and psychically suitable to carry out particularly difficult technical work

- Have been adequately trained on the use and maintenance of the vehicle and equipment
- Have been judged suitable by the employer to carry out the work entrusted to them
- Are able to understand and interpret the manual and the safety requirements
- Know the emergency procedures and their activation
- Have the ability of activating the specific type of vehicle or equipment
- Are familiar with the specific standards of the case
- Have understood the operational procedures defined by the Manufacturer of the vehicle or equipment

2.5 - Classification of dangers

Carefully read the safety regulations given and follow all recommended precautions in order to avoid potential risks and safeguard your health and safety.

The symbols listed below are inserted to highlight situations which **DIECI S.R.L.** considers particularly important.

If in doubt, contact your agent or dealer.



DANGER

It indicates an imminently hazardous situation which, if not avoided, could result in death or serious injury.



WARNING

It indicates a potentially hazardous situation which, if not avoided, could result in death or serious injury.



ATTENTION

It indicates a potentially hazardous situation which, if not avoided, could result in minor or moderate injury.

**ATTENTION**

Used without the safety warning symbol, it indicates a potentially hazardous situation which, if not avoided, could result in property damage.

**NOTE**

It indicates information or a company policy that relates directly or indirectly to personnel safety or to property protection.

**NOTE**

It indicates an optional accessory or attachment.

2.6 - Vehicle general warnings

Every vehicle or equipment comes with a copy of its own manual.

**ATTENTION**

Reproduction of all or part of the contents of this manual or of the multimedia attachment, if any, is prohibited.

Dieci s.r.l. will protect the ownership rights of these materials.

**ATTENTION**

It is compulsory to read and understand this manual before using the vehicle or various equipment and to carefully follow the indications therein. The instructions for use, maintenance and repair described in this handbook must be followed if the vehicle is to be considered as being operated in accordance with the manufacturer's intended uses.

**NOTE**

DIECI s.r.l. reserves the right to carry out possible modifications to the vehicle or equipment for technical or commercial reasons without prior notice.

- A copy of the use and maintenance manual relative to vehicle parts or equipment of the respective suppliers can be supplied. These

manuals are written by the respective product suppliers and reproduced accurately and in full by *DIECI s.r.l.* with their specific authorization: they can be enhanced with further specifications drawn up by *DIECI s.r.l.*

- This Use and Maintenance manual is also provided by the Dealer upon delivery of the vehicle, in order to make sure that these instructions are read and correctly understood. Should you have trouble understanding any part of this manual, do not hesitate to contact your nearest Dealer for clarification.
- All documentation provided constitutes an integral and important part of the product and must always be available to users.
- The instructions for use, maintenance and repair described in this handbook must be followed if the vehicle is to be considered as being operated in accordance with the manufacturer's intended uses.
- This manual assumes that the health and safety standards in the work place, in force in the place of use of the vehicle and of the equipment, are complied with.
- This Use and Maintenance Manual in the user's language, must be carefully stored on the vehicle at all times in an accessible and well known place to all users. If the manual becomes creased and/or be, even partially, damaged or illegible or in case of loss of the manual, it must be replaced immediately by contacting the Dieci Technical Assistance Service, giving the details of the manual found in the "Introduction" chapter.
- Improper, incorrect, or irrational use of the vehicle or the accessories with which it is equipped as well as modification to its physical structure or operation is prohibited. A different use is strictly prohibited and relieves *DIECI s.r.l.* from responsibility for damage caused to persons, things or animals.
- *DIECI s.r.l.* is not liable for damage caused by negligent use of this vehicle or the accessory even if said damage is not a result of intentional improper use. Everything possible has been done during the design and construction phases of vehicles and accessories to make your job as safe as possible. Due caution, however, is indispensable and there is no better rule to prevent accidents.
- To correctly use the components and vehicle controls recalled in the following pages, refer to the specific use and maintenance manual of the vehicle.

- If the vehicle or the equipment must be used in particularly severe conditions (for example: In dusty environments or worksites, on argillaceous or muddy terrain), we advise consulting your nearest dealer for specific instructions. Failure to observe these instructions may result in the vehicle's guarantee being voided.



WARNING

For your safety and the safety of others, do not change the structure or adjustment of the various components of the vehicle or equipment.



NOTE

The right and left positions indicated in this manual refer to the view of the operator sitting in the driver's seat (looking forwards).

2.7 - Equipment general warnings



WARNING

Only equipment CE certified by the relative manufacturer can be used on DIECI vehicles, as well as equipment approved or falling within the technical limits set out by DIECI S.r.l.

Before commissioning any kind of accessory make sure about its compatibility with the operating vehicle and about the calibration of the safety system related to the accessory used.

DIECI S.r.l. liability shall not be involved if equipment use or modifications do not comply with the above mentioned requirements.

2.8 - Intended use

The vehicle or equipment described in this document must be used only for the purposes set out in this Use and Maintenance manual.

Adherence to and strict compliance with the terms of use, repair and maintenance, as specified by the Manufacturer, are essential elements covered by the intended use.



WARNING

The vehicle and equipment must be used **ONLY** by trained and qualified personnel who is aware of the information contained in this Manual.

2.9 - Contraindications for use

The vehicle or equipment must **NOT** be used:

- For recipients other than those listed in the "Recipients" chapter
- For uses other than those mentioned in this manual
- In environmental conditions other than those listed in chapter "Environmental Conditions"
- In use on the road, use the vehicle only if in possession of a valid driver's license in accordance with the regulations in force in the country of use
- Do not use the movable hydraulic parts of the vehicle to lift persons (except with special man baskets)



NOTE

For any other use of the vehicle or equipment, other than those mentioned above, the Manufacturer will reserve the right to revise the terms of the warranty.

2.10 - Declaration of first test

Manufacturer's declaration of first test

DIECI s.r.l. declares that each vehicle and equipment manufactured at its plants, before placing on the market, has been subjected to static and dynamic tests designed to verify proper operation and compliance with EU directives to which it is subject.

At the conclusion of the tests performed, the CE certification of the tested vehicle will be issued.

Each *DIECI s.r.l.* product with CE marking is provided with the related certificate, which must be kept by the rightful owner according to the requirements of law.

2.11 - Liability

- The vehicles and equipment are built according to the EC Directives in force at the time of sale;

- Failure to follow the instructions for use and safety or the use of the vehicle in good working order can not cause accidents criminal offense;
- The manufacturer is not liable for damage caused to persons, animals or property resulting from improper use of the vehicle or equipment or from unauthorized structural changes, applications, and transformations;
- The Manufacturer also reserves the right to make any changes to the vehicle or equipment for any technical and commercial requirement without notice.

2.12 - Manufacturer

DIECI s.r.l.

Via E. Majorana, 2/4
 42027 Montecchio Emilia (RE) ITALY
 Tax Code 01283560686 VAT No. 01682740350
 Tel. +39 0522 869611 - Fax +39 0522 869744
 email: info@dieci.com

2.13 - Vehicle identification label

The identification label (fig. 160550-1) shows the main identification data of the agricultural tractor vehicle.

NOTE! Refer to the "Identification" chapter of the vehicle use and maintenance manual to know the position of the label in the cab.

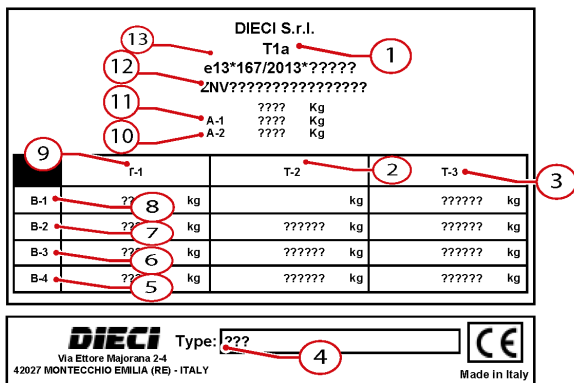

Figure: 160550-1

1	Category
---	----------	-------

2	Rigid drawbar trailer
3	Central axle trailer
4	Type
5	Total mass towable with pneumatic braking (kg)
6	Total mass towable with hydraulic braking (kg)
7	Total mass towable with independent braking (kg)
8	Total mass towable with unbraked trailer (kg)
9	Drawbar trailer
10	Permissible load on the rear axle (Kg)
11	Permissible load on the front axle (Kg)
12	Identification number
13	Homologation number

To ensure a prompt and efficient service when ordering parts or when requesting information or technical clarification always specify the identification details.

Therefore we recommend to note the data relating to the accessory in your possession in order to safely and quickly identify them in the future, in case of need.



Figure: Fig. 160719

The identification label (fig. 160719) shows the main identification data for construction machinery.

1	Type
---	------	-------

2	Homologation number
3	Identification number
4	Total permissible mass (kg)
5	Permissible load on the front axle (kg)
6	Permissible load on the rear axle (kg)
7	Permissible towable mass (kg)
8	Total unladen mass (kg)
9	Power (kW)
10	Year of construction
11	CE Marking (if installed)

The identification label (fig. 160719-1) shows the main identification data of the boom.



Figure: fig. 160719-1

1	Type (machine name)
2	Year of construction
3	Ground

2.14 - Certification and CE marking

The vehicle and related equipment are manufactured in accordance with the relevant EU directives and applicable at the time of its release on the market.

The analysis of all the essential safety health and requirements was carried out during the design and construction in order to verify the applicability and the consequent compliance. Where the analysis has detected an initial lack of conformity, the problems were corrected with appropriate solutions in order to satisfy these requirements.

Here following is shown a facsimile of the certification attached to the vehicle.



DICHIARAZIONE DI CONFORMITA' CE

CE

(Direttiva macchine 2006/42/CE, allegato II, parte A -Direttiva compatibilità elettromagnetica 2014/30/UE, allegato IV)

Prodotto: *****

Nome del Fabbricante: DIECI S.r.l.
Indirizzo: Via E. Majorana, 2-4 - 42027 Montecchio Emilia (RE), Italia

La presente dichiarazione di conformità è rilasciata sotto la responsabilità esclusiva del fabbricante.

Oggetto della dichiarazione:

Il carrello elevatore telescopico Tipo *** ** (***** ***) Matricola *****

L'oggetto della dichiarazione di cui sopra è conforme ai requisiti applicabili di cui alle seguenti direttive:

- Direttiva Macchine - **2006/42/CE**
- Direttiva Compatibilità elettromagnetica - **2014/30/UE**
- Direttiva sull' emissione acustica ambientale delle macchine - **2000/14/CE** procedura allegato VIII

Organismo notificato Dir.2000/14/CE (D.lgs.262/02): NB 0477 – EUROFINS Product Testing Italy srl - Via Cuorgnè 21, 10156 Torino

Informazioni supplementari:

Nome e indirizzo della persona autorizzata a costituire il fascicolo tecnico:
 SIG. ENNIO MANGHI
 presso DIECI S.r.l. - Via E. Majorana, 2-4 - 42027 Montecchio Emilia (RE), Italia

Potenza netta installata: ** kW **** Stage **

Livello di potenza sonora misurata: L_{WA}m = 1** dB(A)

Livello di potenza sonora garantita: L_{WA} = 1** dB(A)

Targa riportante marcatura CE è applicata sulla macchina.
Firmato a nome e per conto di: Ennio Manghi, Amministratore di DIECI S.r.l.

Montecchio Emilia, **,.2019**

DIECI SRL
Via E. Majorana, 2-4
Montecchio Emilia (RE)
 Un Amministratore



Via E. Majorana, 2-4 • 42027 Montecchio Emilia • (Reggio Emilia) ITALY
 Tel. ++39 0522 869611 - Fax ++39 0522 869798 (Reception) - Fax ++39 0522 869797 (Amn.ne)
www.dieci.com • E-mail: info@dieci.com

Cap. Soc. Int. Vers. € 10.000.000,00 Reg. Impr. R.E. N. 01283560686 R.E.A. R.E. N. 204278 - C.F. 01283560686 • P.I. 01682740350



2.15 - Units of measurement and abbreviations used

DECIMAL METRIC SYSTEM (IS)		ENGLISH IMPERIAL SYSTEM (IMP)	
NAME	SYMBOL	NAME	SYMBOL
SURFACE			
square meter	m ²	square foot	ft ²
ELECTRICITY			
Ampere	A		
Volt	V		
FORCE			
kiloNewton	kN		
Newton	N		
FORCE TIMES LENGTH - TORQUE			
Newton-meters	N·m	pounds inch	lb·in
FORCE TIMES SURFACE AREA - PRESSURE			
kilopascal	kPa	pound/square inch	psi
ROTATION FREQUENCY			
Revolutions per minute	rpm		
LENGTH			
kilometer	km	mile	mi
meter	m	foot	ft
centimeter	cm	inch	in
millimeter	mm	inch	in
MASS			
kilogram	kg	pound	lb
ton	t	pound	lb
POWER			
kilowatt	kW	horse power	hp
Watt	W		
TEMPERATURE			
degrees Celsius	°C	degrees Fahrenheit	°F
SPEED			
kilometers per hour	km/h	miles per hour	mph
meters/second	m/s	feet/second	ft/s
VOLUME			
cubic meter	m ³	cubic yard	yd ³
		cubic inch	in ³
liter	l	UK gallon	UK gal
TIME			
hour	h	hour	h
minute	min	minute	min
second	s	second	s

VOLUME TIMES TIME

cubic meter per minute	m ³ /min	cubic foot per minute	ft ³ /min
liter per minute	l/min	UK gallon per minute	UK gal ³ /min

SOUND POWER AND ACOUSTIC PRESSURE

decibel	dB		
---------	----	--	--

3.1 - Exclusions from the guarantee

The guarantee does not include:

- All consumables and those subject to normal wear and tear (e.g. batteries, clutch/brake discs, lubricants, filters, belts, fuel ...);
- All consumables such as oil and liquids;
- Damages and/or breakages deriving from failure to comply with/implement the operations recommended in the periodic maintenance programs illustrated in the "Use and maintenance manual";
- Damage caused by incorrect repair carried out by unauthorized workshops/personnel;
- Damages for lack of production and/or loss of the product;
- Costs for the rental of a replacement vehicle during the vehicle standstill period for repairs under warranty;
- Breakage of all types of glass, windows (doors, rear window, windshield).

3.2 - Delivery and installation

The dealer has the obligation to perform a set of operations when the vehicle is delivered to the customer. These include a complete check to ensure that the vehicle can immediately operate, an explanation on the safety regulations and a detailed explanation on the instructions contained in the "Use and maintenance" booklet regarding use of vehicle controls, the vehicle maintenance, starting up and stop operations and the use of all the parts. All people who use the vehicle must participate in the training.

For the period of coverage of your vehicle, check the terms in the guarantee certificate.

The guarantee consists in the restoration of the efficiency of parts that are unusable or inefficient due to factory defects through their replacement with original spare parts or through no-charge repair; the costs of transport/travel of the vehicle from the final customer to the dealer/importer and/or to its authorized workshops are excluded, and vice versa.

The warranty is valid only if the vehicle has been used correctly according to the manufacturer's instructions and has not been tampered with, and is immediately terminated if modifications and/or repairs to the vehicle are carried out by personnel not authorized by DIECI.

The warranty also expires in the following cases:

- Failure to comply with, and carry out, the maintenance schedules and mandatory services prescribed by the manufacturer;
- Changes made without the manufacturer's consent;
- Repairs or maintenance carried out with non-original spare parts;
- Incorrect use of the vehicle;
- Carelessness, accidents, late notification of the defect, improper use of the vehicle, damage caused by prolonged use of the vehicle in conditions of declared failure;
- Improper use of equipment or their incorrect assembly;
- Use of lubricants/fuel with specifications other than those prescribed and recommended by the company DIECI.

DIECI is not liable for damage to the vehicle caused by incorrect use or malfunctions of other equipment connected to the vehicle.

The warranty covers only damages and/or malfunctions of the vehicle without the user being able to claim damages for production losses, for presumed or proven damage to equipment connected to the vehicle itself.

3.3 - Warranty: duration

The **DIECI s.r.l.** company guarantees its products for 12 months or 1500 hours from the date of delivery to the customer user or to the Dealer/Distributor.

If the vehicle is stored for long periods by the Dealer/Distributor at the time of sale to the customer, the Service Center will reserve the right to verify guarantee activation.

3.4 - Warranty: commencement

The guarantee is valid from the date the vehicle is shipped from the factory (sales to Distributors or Dealers). When delivery is handled by the Distributor or Dealer, **DIECI s.r.l.** reserves the right to verify that the guarantee start date corresponds to the shipping or delivery date on the transport document of the product being guaranteed, and/or to the invoice date, and can request original copies of these documents.

3.5 - Warranty: activation

The guarantee is automatically valid from the date the vehicle leaves the factory (sale to Distributors or Dealers).

3.6 - Warranty procedure

The correct use of the vehicle, associated with regular maintenance, can do much to prevent breakdowns. If, however, malfunctions should occur during the warranty period, the following procedure is recommended:

- Immediately inform the dealer from whom the vehicle was purchased, indicating the model and serial number. The end customer has the obligation to report any flaw or defect regarding the vehicle no later than 8 days from its discovery, under penalty of cancellation of the warranty;
- Give your dealer as much information as possible. So he can know the number of hours of service performed, the type of work you are doing and the symptoms of the problem.

Remember that normal maintenance operations, such as brakes/clutch setting up and adjustment, as well as the supply of materials used for servicing (oil, filters, fuel and antifreeze) are not covered by warranty.

3.7 - Intervention campaigns for faulty products

The replacement procedures of parts acknowledged to be faulty will be agreed upon by **DIECI s.r.l.** and its distributors/dealers/authorized workshops.

These intervention campaigns can be followed directly by **DIECI s.r.l.** suppliers, who are responsible for supplying the components to be replaced (interventions authorized by **DIECI s.r.l.**).

The above interventions will be preceded by written communication from **DIECI s.r.l.** to its purchasers.

Only **DIECI s.r.l.** can decide the intervention method (repair, replacement or modification).

3.8 - Warranty: intervention request

3.8.1 - Guarantee: claim

The claim of the faulty part must be made by the Customer, Dealer, Distributor or Authorized workshop and must be sent directly to **DIECI s.r.l.** Customer Service within 8 days from when it is noted.

The claim must include a clear description of the defect and precise references to the vehicle and equipment (type, model, and serial number). This information can be found on the places indicated in the USE AND MAINTENANCE MANUAL.

3.8.2 - Obligation of vehicle downtime

If there is a risk that the defect may jeopardize safety and accident prevention or may cause further damage, the vehicle or the equipment must not be used until it has been repaired and tested.

Any change made on the vehicle or equipment involves a reassessment of conformity with the Machinery Directive 2006/42/EC. This procedure also applies in the case of repairs with non-original parts.

In the event of any dispute, exclusive jurisdiction will be held by the Court of Reggio Emilia - ITALY.

3.9 - Non-activation, failure to grant, termination

3.9.1 - Warranty: failure to grant

The guarantee is not granted:

- If the defect is not reported as described and within the established time limit.
- If the customer does not comply with **DIECI s.r.l.** request to return the faulty parts replaced during the repairs.
- If the customer has not complied with the obligation to stop using the vehicle after making a claim, limited to damages caused by noncompliance.

3.9.2 - Guarantee: termination

The guarantee is terminated:

- If the buyer does not fulfill contractual payment obligations.
- If damage has been caused by carelessness, negligence, or by use of the vehicle for purposes not in compliance with specifications provided in the use and maintenance manual (incorrect manoeuvres, overloading, use of incorrect fuel, poor maintenance, disregard for warning indicator instruments etc.)
- If the defect is a result of applications, equipment, modifications or repairs not authorized by **DIECI s.r.l.** or carried out using poor quality parts. (For this reason, we recommend always using original spare parts).



NOTE

Refer to the "MAINTENANCE" paragraph for information regarding recommended routine maintenance.

3.10 - Final terms

In none of the cases regarding non-activation of the guarantee, it not being granted or being terminated, the buyer cannot request the cancellation of the contract, or compensation, or an extension of the guarantee.

Any guarantee conditions other than those listed above must be agreed upon in writing and signed by both parties.

Unless agreed upon in writing by both parties; **Dieci s.r.l.** does not pay compensation for any type of claim caused by vehicle downtime, such as:

- Replaced or rented vehicles or equipment
- Labor
- Loss of profit

4.1 - General warnings

The instructions for use, maintenance and repair described in this handbook must be followed if the vehicle is to be considered as being operated in accordance with the manufacturer's intended uses.



DANGER

THE VEHICLES AND EQUIPMENT MAY NOT BE MODIFIED WITHOUT PERMISSION OF THE MANUFACTURER.

For your safety and the safety of others, do not change the structure or adjustment of the various components of the vehicle or equipment. The same applies to the deactivation or modification of the safety devices present. Any changes made to the vehicle or equipment, holds DIECI s.r.l. harmless from any liability arising from damage or injury.

Every vehicle or equipment must be used, assisted or repaired only by persons that have received training in advance on the vehicle and on its safety regulations, in addition to being authorized to use the vehicle or equipment itself.



NOTE

The user must always observe the general safety regulations as well as those for accident prevention, such as traffic rules if the vehicle is used on public roads (according to the regulations in force in the country of use).

DO NOT USE THE VEHICLE OR THE ACCESSORIES IF YOU ARE UNDER THE EFFECT OF ALCOHOL, DRUGS OR IF YOU HAVE TAKEN MEDICINES THAT MAY MAKE YOU DROWSY OR MAY ALTER YOUR REFLEX AND REACTION TIME.

DIECI s.r.l. is not liable for damage caused by negligent use of this vehicle or the equipment even if said damage is not a result of intentional improper use. Everything possible has been done during the design and construction phases of vehicles and accessories to make your job as safe as possible. Due caution, however, is indispensable and there is no better rule to prevent accidents.



DANGER

THE VEHICLES OR EQUIPMENT IN QUESTION ARE NOT SET-UP FOR USE IN ENVIRONMENTS OR SITES EXPOSED TO THE PRESENCE OF EXPLOSIVE GASES, THUS USE IN THESE PLACES IS PROHIBITED.

To operate in these environments, the Manufacturer must be contacted so that the necessary modifications can be made to the vehicle and/or equipment.



DANGER

All functions and procedures concerning the operation and mounting of the vehicle or its equipment that are not described in this manual are strictly FORBIDDEN.



WARNING

Read all of the safety stickers on the vehicle and on the equipment and observe all regulations printed on these stickers before starting up, running or refueling the vehicle or before carrying out maintenance work. Immediately replace damaged, lost or illegible stickers. Clean them when they are covered by mud, concrete or debris.

- Do not use the vehicle or equipment without having first read and understood all parts of this manual, and without having attended an adequate training course.
- Do not use the vehicle or equipment when hands or shoes are wet or dirty with grease or greasy substances.
- Verify that all safety devices function before using the vehicle or the equipment. The operator must always maintain control of the vehicle and equipment state and operation.
- Use the audible warning device or other signals to alert people in the area before starting up the vehicle.
- Inspect control instruments immediately after start up, while the engine is hot and at regular intervals during use, in order to promptly recognize and resolve any malfunctions.
- Do not use the vehicle or equipment if a danger label or a maintenance in progress label is placed inside the cab.

- Do not carry passengers on the vehicle or in the driver's cab or on any other part of the vehicle (including man basket).
- It is prohibited to use the mobile hydraulic parts of the vehicle to lift people except when using the man baskets with relative personal protective equipment for the operator inside.
- Regardless of the user's experience, become familiar with the position and function of all controls and instruments in a work area free from obstacles and persons, before operating the vehicle or the equipment.
- Carry out all the described safety checks before resuming operations.
- While the vehicle is running, always keep light signals on. These serve to warn people that the vehicle is about to move.
- Always keep the safety distance adequate for the type of work and persons or objects in the work area. Always look in the travel direction and maintain good road visibility.
- Adjust movement speed based on the load carried and the type of ground; remain at low speeds to reduce the risk of the vehicle tipping over or losing the load.
- Do not drive with the brake pedal pressed.
- Do not use the vehicle force of impact to carry out tasks. These vehicles are not designed for said use; therefore, such use may cause vehicle overturning, damage, the breakage of components and attachments, or serious personal injury for the user.
- Always operate with the engine hood closed.
- Do not operate with the vehicle protective parts removed.
- When working in a congested area, designate one person to signal and coordinate the work zone.
- Make sure that everyone follows the directions given by the person in charge of signaling.
- Make sure to use signals that conform with the provisions in force in the country of use of the vehicle.
- For additional information with regard to the presence of a person in charge of signaling, consult the "Signals to more vehicles" chapter.
- When working alongside excavations or on the edge of the road or soft ground, keep at a safe distance as the vehicle may overturn.
 - Designate a person on the ground to be in charge of signaling.
 - Remember that after strong rains, the use of explosives or an earthquake, the ground is more fragile.
- When working on the upper part or inside buildings or other structures, verify their capacity and stability before starting operations. The risk of collapse exists and can cause serious injuries or damage.
- Working on a slope may be dangerous. The conditions of the terrain may vary according to climatic conditions (e.g. rain, snow, ice). Therefore, pay careful attention to the conditions of the terrain on which the vehicle is being used; the use of low speeds is recommended.
- Drive slowly on grass, leaves or wet steel slabs. Even when operating on slight slopes the vehicle may slip or lose balance with risk of tipping.
- Tipping conditions of the vehicle can vary depending on the features of the ground, environmental conditions and the type of work. Complying with all the safety instructions contained in this manual reduces risks for the vehicle and the operator in most operating conditions provided herein.
- It is forbidden to use the tractor if there is any risk of tipping that is not covered herein, as this manual contains an incomplete list.

4.2 - Safety indications



ATTENTION

Carefully observe and follow all safety signals on the vehicle and on the equipment and read all safety messages in this manual.

- The safety messages in this chapter illustrate the basic safety procedures of the vehicles and equipment.
- The safety signals must be installed, maintained and replaced when necessary.
- If a safety signal or this manual is damaged or missing, order a replacement from the **DIECI s.r.l.** dealer in the same way in which spare parts are ordered (be sure to communicate the model and serial number of the vehicle when placing the order).
- Learn how to correctly and safely operate the vehicle and the equipment and their relative controls.

- Allow only trained, qualified and authorized personnel to operate the vehicle and installed equipment.
- Keep the vehicle, equipment and accessories in appropriate working conditions.
- Unauthorized modifications to the vehicle, to the equipment or accessories can jeopardize their operation and/or safety and influence their lifespan.
- In case of doubt, contact the manager before proceeding to operate or carry out maintenance work on the vehicle or on the equipment.

4.3 - Personal protective equipment

In some cases, when working in particularly uncomfortable environments, adequate clothing or equipment must be worn.

It is mandatory for the operator, before starting to work, to learn from the safety manager or the site manager which are the possible risks of the work and which accident prevention clothes he must wear.



ATTENTION

Always use PPE that is appropriate for the type of work to be performed.

The Personal Protective Equipment used by the operators can have different characteristics, depending on the type of construction site and risks present in the work place.



ATTENTION

Keep the personal protective equipment in good conditions.

Accident prevention clothes must always be intact and in good condition. Damaged clothing cannot ensure adequate protection. Do not wear damaged clothing; always replace damaged or torn clothing before operating the vehicle.

4.3.1 - Protective clothing

Icon	Refilling	Description
	ISO7010: M004	Wear protective goggles
	ISO7010: M008	Wear safety shoes

Icon	Refilling	Description
	ISO7010: M009	Wear protective gloves
	ISO7010: M015	Wear high visibility clothing
	ISO7010: M013	Wear a protective mask (for work in dusty environments)
	ISO7010: M017	Use a protective breathing apparatus (for work with dangerous substances)
	ISO7010: M018	Wear a safety harness



DANGER

Danger of crushing

Pay attention to moving parts to avoid danger of crushing or dragging of the lower and upper limbs. Avoid wearing jewelry or pendants that might be trapped in moving parts. Long hair must be tied back to avoid it being caught in moving parts.

Do not wear loose clothing, chains, belts or other accessories that may be caught in the control levers or in other parts of the vehicle or equipment.

4.3.2 - Protect yourself against noise

Prolonged exposure to loud noise can damage your hearing or may cause hearing loss.

Icon	Reference	Description
	ISO7010: M003	Wear hearing protection



ATTENTION

Always wear anti-noise earmuffs or earplugs to protect yourself from excessive and irritating noise.

4.3.3 - Protections against objects falling from height

Icon	Reference	Description
	ISO7010: M014	Wear a helmet



DANGER



Danger of falling objects

Use of a safety helmet is required if there is a risk of falling objects.

4.3.4 - Protect yourself from flying fragments

Icon	Reference	Description
	ISO7010: M013	Wear a face shield



WARNING

During operation in certain conditions, particles of material may be ejected. In such conditions, it is a good idea to wear protective goggles and clear the area of those people not in possession of such goggles.

4.4 - Preparing for accidents

- Always be prepared in the event of a fire or an accident.
- Keep a fire extinguisher and first aid kit at hand. (Not supplied by the manufacturer, "optional accessories").
- Carry out periodic inspections to ensure that the first aid kit contains all necessary items; replenish content if necessary.
- To properly use the extinguisher, carefully read the instructions located on the extinguisher.
- Carry out periodic inspections and maintenance (six monthly) to ensure that the extinguisher is ready for use at any given moment.

- Create priority procedures to deal with fires or accidents.
- Keep emergency telephone numbers (doctors, ambulance, hospital and fire brigade) clearly visible and near the telephone.
- Adequately trained and educated personnel must be present for managing emergencies with adequate theoretical-practical course carried out on site.

Below are some First Aid procedures that can be activated in case of accident following use of the vehicle or equipment object of this use and maintenance manual.

These procedures may be useful in an emergency for the users or other operators present near-by, during use and various life phases of the vehicle or of the equipment (transport, installation, use, maintenance, adjustment, etc.).

4.4.1 - First Aider Tasks

1. Activate first aid (emergency call).
2. Evaluate the victim and, if necessary, support vital functions.
3. Stop an external hemorrhage.
4. Protect wounds and burns.
5. Protect the victim against further damages.
6. Do not perform unnecessary or damaging actions, such as giving beverages, moving the victim, reducing dislocations and/or fractures, etc.

4.4.2 - Emergency call

Good first aid intervention also depends on the timely arrival of rescuers (emergency medical support) to the place of the emergency.

This is why the first aider in charge of calling the emergency must precisely indicate:

- Address of where the accident or illness took place.
- Number of injured or ill persons.
- The possible cause of the event.
- The state of the vital functions of the injured party, specifying whether the same is conscious or not and breathes normally or not.

At the end of the call it is recommended to:

- Give own details, indicating a telephone number where to be contacted.
- Wait for rescuers in an easily accessible and visible location.

4.4.3 - Traumas

Distortions, dislocations and fractures:

Immobilize the joints in the position after the trauma, using bandages or splints, supporting the analgesic position of the injured party without attempting dangerous manoeuvres. Apply the cold (with bag of ice or other systems). In case of exposed fracture, cover the wound using a sterile gauze pad, after having pressed at a distance on the specific points the relative hemorrhage.

Contusions, crushing:

In case of contusions and/or crushing of ends of the upper and lower limbs (fingers, hand, feet, etc.) it is advised to immediately place the limb underneath running water (cold) and apply ice. Also check for wounds and/or cuts in the hit area and, if necessary, disinfect with the due precautions.

4.4.4 - Hemorrhages

It is necessary to press the fingers on the hemorrhage point with sterile gauze pad, lifting the limb and eventually compress upstream of the hemorrhage with tourniquet. Wear protective gloves in case of contact with body fluids.

Treating superficial wounds:

Carefully expose and clean the wound, disinfect it with physiological solution, medicate it covering it with sterile gauze pads. Bandage avoiding excessive tightening to allow good circulation.

Treating deep wounds:

It is a priority to protect yourself against the risk of infection using gloves and splash shield; pad the hemorrhage by direct pressure or using other pressure points until it stops or the arrival of the ambulance. Call the medical emergency number, informing them that you are padding an arterial hemorrhage.

Treat the wound only after the hemorrhage is under control.



ATTENTION

Do not use cotton wool, methylated spirit, antibiotic powder to disinfect the wound.

4.5 - Preventing fires and accidents

4.5.1 - Risks of fires



DANGER



Danger of fire



It is forbidden to smoke or use naked flames during use and maintenance operation of the vehicle and equipment.

Do not operate the vehicle or equipment without the following safety conditions:



DANGER

Fuel, oil and lubricant leaks can trigger fires and cause serious injuries.

- Ensure that there are no flammable liquids leaking.
- To avoid oil or diesel leaks, make sure that there are no loose or missing clamps, no twisted flexible pipes or that rub up against each other.
- Do not bend any pipes under pressure.
- Never install damaged pipes.
- Do not weld piping or pipes containing inflammable liquids.
- Do not use a torch head to cut piping or pipes containing inflammable liquids.



DANGER

Short circuits may cause fires.

- Ensure that there are no short circuits.
- Clean and interrupt all electrical connections.
- Check before each work shift that there are no loose, twisted, hardened or damaged electrical cables.



DANGER

Fuel, oil, grease, waste, deposits or accumulated dust or other components can cause a fire.

- Remove inflammable materials.
- Prevent fires by inspecting and cleaning the vehicle at every shift, by immediately removing inflammable components.

- Check the ignition switch: in the event of fire, failure to switch off the engine will obstruct the work of the Fire Brigade.
- Do not use naphtha, petrol or inflammable liquids to clean parts of the vehicle. Only use non-flammable detergents.



DANGER

Safely handle dangerous liquids

- Handle fuel with care, it is easily inflammable. If fuel is ignited, there may be an explosion and/or a fire.
- Do not refuel the vehicle while smoking and in presence of naked flames or sparks.
- Always stop the engine before refueling the vehicle.
- Fill up the tank outside.
- All fuels, most lubricants and some anti-freezes are inflammable.
- Preserve the flammable fluids away from fire hazards.
- Do not burn or drill pressurized containers.
- Do not keep cloths soaked with lubricant; they may cause fires and spontaneous combustions.

4.5.2 - Risks of inhaling gas



DANGER

Exhaust engine gases are toxic and can cause damages to your health.

If it is necessary to work in closed ambients, ensure it is sufficiently ventilated and equip the vehicle with special purifiers.

4.5.3 - Risks of batteries exploding



DANGER

The gas of the batteries may explode.

- Keep any sparks, open flames or lit cigarettes away from the upper part of the battery.
- Never place a metal object between the clamps to check the battery charge. Use a voltmeter or a densimeter.
- Do not create sparks in the battery connection during recharging phases or starting the engine with auxiliary battery.
- Do not charge the batteries if they are extremely cold, extremely hot or damages as they might explode.
- The ideal temperature for the recharging of the batteries is 16 °C (60,8 °F).
- The electrolyte in the batteries is an extremely corrosive acid.
- Should the battery explode, the electrolyte may be sprayed in the eyes with the possibility of causing blindness.
- Ensure to be wearing protective goggles when carrying out maintenance on the batteries.
- Do not overturn or tilt the battery as acid could come out.

4.5.4 - Residual risks



DANGER

Damage may be caused by entanglement in moving parts.

Keep away from moving parts.



DANGER

Avoid burns.

Stay away from hot parts.

Jets of hot fluids:

After operation, the engine cooling liquid is hot and under pressure. Contact with hot water or steam may cause serious burns.

Avoid possible injury caused by hot water jets. Do not remove the radiator cap until the engine has cooled down. To open it, unscrew the cap as far as possible. Before removing the cap, release all of the pressure.

Hot surfaces and fluids:

The engine, reduction gears and hydraulic system oil heat up during vehicle use. The engine, rigid and flexible pipes and other components heat up.

Wait until all components cool down before beginning maintenance or repair work.



DANGER

Caution with pressurized fluids.

Fluids such as fuel or hydraulic oil under pressure can penetrate the skin and eyes causing serious injuries.

Avoid these dangers while repairing or carrying out maintenance on the vehicle, discharging the pressures (using the hydraulic levers of the distributors) before disconnecting or repairing pipes and hydraulic parts.

Before restarting the engine, ensure that all fittings have been correctly tightened.

Use a piece of cardboard to check for any leaks; make sure your hands and body are adequately protected against pressurized fluids. Wear a face mask or accident-prevention goggles to protect your eyes.

Should there be an accident, seek medical attention immediately. Any fluids that penetrate the skin must be removed surgically within a few hours to avoid infections.



DANGER

Electrocution

All maintenance and/or adjustment interventions on powered parts must be carried out only and exclusively by qualified and adequately trained personnel.



DANGER

Risk of slipping.

During on-site operations, the areas around the equipment may have debris and liquid (oil, water, etc.) that might make the floor slippery. Pay the utmost attention.



DANGER

Risk of falling, tripping.

Pay the utmost attention when climbing in and out from the vehicle.



DANGER

Crushing of hands and feet.

The presence of moving parts during operation can cause risks for the ground operators. During vehicle movements, carefully check no unauthorized person is within the required moving area.

4.5.5 - Contact with dangerous substances

- Wear the necessary protective clothing.
- Refer to the safety data sheet of the product used and take appropriate precautionary measures when using the product.
- Avoid contact with skin and eyes
 - In case of contact with eyes: rinse them thoroughly with plenty of water for a few minutes keeping the eyelids open and seek medical attention.
 - Should any fluid come into contact with skin, wash the area carefully, remove contaminated clothing, and when skin is dry, apply moisturizing cream. Consult a doctor if necessary.
 - In the event of inhalation, move away from the contaminated area and go to a well-ventilated location. Consult a doctor in the event of respiratory problems.
 - If swallowed: immediately contact a doctor, showing the label or container. Do not induce vomiting to avoid the risk of inhalation via respiratory passageways.

4.6 - Storing dangerous liquids



DANGER

Flammable material danger.

All fuels, most lubricants and some anti-freeze fluids are inflammable.

Handle fuel with care, it is easily inflammable. If fuel is ignited, there may be an explosion and/or a fire.



WARNING

All fluids must be kept out of the reach of children and non-qualified persons.



WARNING

Do not store together or mix different types of substances.



DANGER

All chemicals are generally very harmful to health.

Avoid contact with skin and eyes by wearing appropriate protective clothing; do not swallow.



DANGER



It is forbidden to smoke and have open flames



It is forbidden to smoke or use open flames near fuels.

Comply with the following precautions to store dangerous liquids:

- All inflammable fluids must be stored in special containers, and the content must be clearly indicated on each container. Containers must be tightly sealed.
- Store inflammable fluids in well-ventilated locations, far away from heat sources, sparks and open flames.
- Keep containers closed and covered. Other substances (e.g. foodstuffs) must not be present in this location.
- Always fill up the tank when outdoor.
- Be careful of fumes and vapors which may be formed by chemical products. Avoid inhalation.
- Do not breathe in flue gas.
- Ensure that these chemical products do not spill or flow into the ground, sewers or surface waters. If necessary, inform the competent local authorities.
- In the event of a fire, use carbon dioxide, dry chemical powder, foam, sprayed water, sand, earth. Use jets of water to cool down surfaces exposed to the fire.
- Verify that there are no leaks of inflammable liquid (fuel, oil, grease, lubricants in general) in the storage containers.



NOTE

Refer to the safety data sheet of the product for additional precautions and warnings that are to be adopted.

4.7 - Warnings for safe working

4.7.1 - Ensuring the vehicle is clean

- Clean the windows, lights and wing mirrors (if installed).
- Clean dirt and waste away from the engine, articulations and radiator
- Make sure the cab steps and the handle are clean and dry
- Clean all safety stickers and manoeuvring instructions. Replace any stickers that are illegible or missing



WARNING

If the vehicle or equipment is not in perfect working order its operation is strictly prohibited.



NOTE

For the cleaning procedures, refer to the "CLEANING" chapter.

4.7.2 - Checking for damage

- Make sure that there are no damaged or missing parts.
- Make sure that all articulated pins are properly fastened.
- Make sure that there are no signs of possible cracks or flaws or other damage to the windows (if installed).
- Make sure that there are no oil, fuel or cooling liquid leaks underneath the vehicle.
- Make sure that the wheel bolts are properly tightened.



WARNING

If the vehicle or equipment is not in perfect working order its operation is strictly prohibited.

4.7.3 - Start working with the vehicle

Regardless of their level of driving experience, operators must familiarize themselves with the position and function of all controls and instruments before operating the vehicle.

- Before using the vehicle, check location of personnel.

- While the vehicle is running, always keep light signals on. These serves to warn people that the vehicle is about to move.
- When working in a congested area, have another person present for signaling.
- When manoeuvring the vehicle, pay attention to bulky vehicle parts. There are parts that jut out from the cab.
- Never use controls for purposes different than those for which they were created for; e.g. to climb on or off from the vehicle or hang clothing, etc...
- Only use the vehicle from the driver's position.
- The vehicle may move suddenly if started up without following the correct procedure, thus, creating the risk of personal injury.
- Start up the engine from the driver's seat only.
- Never start the engine by causing a short circuit between the terminals of the starter motor.
- Before starting the engine, make sure all control levers are in a neutral position.

4.7.4 - Passengers transportation

Only the operator must be on board the vehicle, passengers are not admitted.

Passengers may obstruct the operator's view, causing an unsafe operation of the vehicle.



WARNING

Carrying people on or lifting people up with the vehicle is strictly prohibited unless the vehicle is equipped with an elevation work platform and has a special certificate of conformity regarding the transport of people.



WARNING

It is strictly forbidden to transport persons inside the basket while the vehicle is moving even in the presence of elevation work platform and certificate of conformity. It is compulsory to use the man basket only with the parking brake engaged and the outriggers lowered (if present).

4.7.5 - Electrical system protection

A burnt fuse must be replaced with another fuse of the same type, amperage and class.

Other types of procedures are not allowed, even if temporary.

Do not connect or remove clamps, fuses, or connectors when the vehicle is switched on or electrically powered.

Any intervention on the electric system must take place with the vehicle not powered electrically. Restore the power supply only after the intervention has been concluded. Remount the lids and protections.

- Use the battery isolation switch to cut off power to the vehicle.
- Cut off power by means of the battery isolation switch even before replacing the vehicle battery.
- In the event that a connector is damaged or is no longer inserted in its housing, replace it immediately in order to avoid short circuits or sparks.

Damaged, pinched or burnt cables must be replaced immediately even if damage is only to the sheathing or outer insulation.



- Never carry out or interrupt any connection on the load circuit, including connections on the battery, with the engine running.
- Never ground (earth) short circuit any charging component.
- Do not use an auxiliary battery with nominal voltage exceeding 12 volt.
- Make sure the polarity is correct when putting in the battery or when using an auxiliary battery when starting the vehicle with cables. Follow the use and maintenance instructions of the manual when starting up the vehicle with cables.



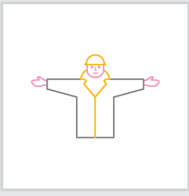
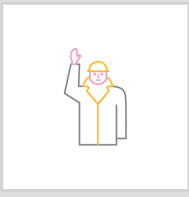
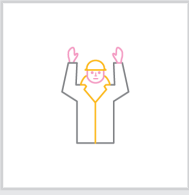
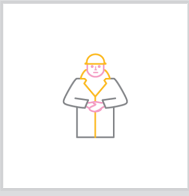

4.7.6 - Signals to multiple vehicles

When working requiring more vehicles, give signals normally known to all employed personnel. Designate one person to signal and coordinate the work zone.

Before operating make sure that:

- The user and signaler are aware of the hand signals to be able to interact between them
- That everyone follows the directions given by the person in charge of signaling
- The signaler must be easily identified by the user of the vehicle
- The signaler must wear or hold one or more adequate recognition elements, like: jacket, helmet, sleeves, bracelets, signal paddles
- The recognition elements must be bright colored, preferably one, and reserved exclusively for the signaler.

Movement	Meaning	Description
	Start - Attention - Order taking	The two arms are open horizontally, the palm of the hands forward
	Stop - Interruption - End of motion	The right arm is stretched upwards, with palm of right hand forward
	Danger - Stop - Emergency stop	Both arms stretched upwards
	End of operations	The two hands are joint at height of chest
	Lift	The right arm, stretched upwards, with palm of right hand forward, makes a circle
	Lower	The right arm, stretched downwards, with palm of the hand towards the body, makes a circle

Movement	Meaning	Description
	Vertical distance	The hands, one on top of the other, indicate the distance
	Horizontal distance	The hands, one next to the other, indicate the distance
	Forward	Both arms are folded, the palms of the hands backwards and the forearms make slow movements towards the body
	Move back	Both arms are folded, the palms of the hands forward and the forearms make slow movements away from the body
	To the right compared to operator	The right arm, stretched horizontally, with palm of right hand downwards, slowly makes small movements towards the direction where to move
	To the left compared to operator	The left arm, stretched horizontally, with palm of left hand downwards, slowly makes small movements towards the direction where to move
-	Quick motion	The conventional signals used to indicate movements are quickly made
-	Slow motion	The conventional signals used to indicate movements are made very slowly

4.7.7 - Working with the danger of falling masses and objects

When working in areas where there is a risk of falling, bouncing or interference from objects capable of hitting the operator or entering the cab:

- Always close the windows.
- Always ensure that other operators near-by are at a safe distance and cannot be hit by bouncing or falling objects.
- Never carry out work operations under an overhang; this could give way and fall onto the vehicle.
- When working from the cab:
 - Mount suitable safety panels to protect the operator.
 - Always close the windows.
 - Pay careful attention to crumbling walls, landslides, falling material or objects from the installed equipment, that may hit the cab, the protective structure or windows, causing damages to the vehicle and to the operator.
 - Do not excessively weigh down or fill the installed equipment or transport loads that may come out or fall on the ground.
- When working from the man basket:
 - Install optionals on the basket such as the roof to provide additional protection to the operators.



WARNING

Danger of falling objects

Use of a safety helmet is required if there is a risk of falling objects.

4.7.8 - Working near electrical lines

Before working near overhead electrical lines, check that the safety distance is sufficient, in compliance with the current Standard in the country of use. In any case, never work near electrical lines at distances shorter than those in the table below or at the minimum distances indicated by the Standards in force in the country of use of the vehicle and of the equipment.

Damp ground may increase the risk of electrocution.

Operating or parking the vehicle too close to electrical cables leads to increased risk of being struck by lightning or being seriously injured.

Designate someone on the ground to signal when too close to electrical cables.

Do not allow anyone near the vehicle when working in the vicinity of electrical cables. To prepare for any possible emergency situation, wear rubber shoes and gloves, cover the seat with a rubber piece of fabric and take care not to touch the chassis with any unprotected body parts.



DANGER

High voltage danger

Should the vehicle or the equipment installed on it collide with an electrical cable, the user, to avoid electrocution, must remain inside the driver's cab until certain that the electrical power supply has been properly disconnected.



DANGER

High voltage danger

If operating close to overhead electrical lines, check the safety distance in the table below, reported in the Italian Legislative Decree 81/08 Enclosure IX. The table is valid if the vehicle is used on Italian territory. However, refer to the Standards in force in the country of use of the vehicle and equipment.

Un (kV)	Distance
≤ 1	3 m (9.84 ft)
1 < Un ≤ 30	3.5 m (11.48 ft)
30 < Un ≤ 132	5 m (16.40 ft)
> 132	7 m (22.96 ft)

4.7.9 - Working under the snow

Snow can hide obstacles and objects, and cover holes, dug-out areas and ditches, therefore, proceed with caution.



WARNING

Operation of the vehicle if the quantity of snow does not allow for clear distinction of obstacles and possible dangers along the path, is strictly prohibited.

- Take care when clearing snow and do not venture off the main road; that which is hidden at the sides of the road may cause vehicle overturning or damage to various components.
- Surfaces covered by snow or ice are extremely dangerous. Operate with caution, reducing vehicle speed as much as possible and engaging levers slowly.

- Operate with caution. If the vehicle should sink into the snow, it may overturn or remain buried. Do not venture from the road and avoid remaining entrapped or buried under heaps of snow.
- Extra care should be taken, when working on icy terrain. The ice will melt as the temperature rises and the ground will become slippery.
- Use caution in the presence of electrical cables, ditches, or freshly excavated or worked ground.
- Make sure not to cause risk to others in the area when backing up the vehicle.
- Always check the space around the vehicle before carrying out any manoeuvres

- Spaces with dangerous or explosive atmospheres.
- Protected environments such as refineries.



ATTENTION

The vehicle must be appropriately modified and certified to work in environments with an explosive atmosphere.

The vehicle can only be used in a tunnel if it has been declared suitable for these environments.



NOTE

If working the vehicle at temperatures below -10°C (14°F), empty and refill the tank using lubricants, fuel or cooling liquids suitable for such temperatures.



NOTE

There are accessories that can be used to facilitate working with ice or snow, contact your dealer or agent.

4.7.10 - Working with scarce lighting



ATTENTION

The standard illumination of the vehicle is not suitable in working conditions with poor visibility or for use at night.

The vehicle can only be used with sufficient lighting in the work area.



NOTE

There are several ways to improve visibility in conditions of poor lighting. Contact your local **DIECI s.r.l.**dealer.

4.7.11 - Working in closed areas or dangerous atmospheres

It is FORBIDDEN to use the vehicle in:

- Suitably ventilated closed spaces, that are nevertheless not compatible for the use of equipment with running endothermic engines.

4.7.12 - Reduce vibrations

Consider the following recommendations to reduce the vibration exposure of the operator:

- Always use the appropriate equipment for the job to be carried out.
- The driver's seat must be properly adjusted to suit the operator needs. Inspect and if required repair the suspensions and the regulation mechanisms of the seat.
- Make sure that the vehicle is kept efficient, perform vehicle maintenance as prescribed in this manual.
- Steer, accelerate, brake, shift gears, move the tool in a non-abrupt way.
- During transfers adjust the speed of the vehicle to minimize the level of vibrations. Reduce speed to avoid the risk of jolting. Transport the vehicle in the event of significant distance between job sites.
- Maintain the workplace in good condition, remove stones and obstacles, fill depressions or holes etc.
- To avoid back pain problems, use the vehicle only in good health.
- Take breaks so as to reduce the time of sitting in the same posture.
- Do not exit the cab or go out of the vehicle with a jerk.
- Avoid to lift and move loads repeatedly.
- Further recommendations to reduce vibration when working with man basket:
 - Use the controls smoothly.
 - Do not make any sudden movements on the man basket.
 - The vibrations generated by the vehicle are not a source of risk when using the basket.

4.8 - Working in windy conditions

Wind speed variation can cause a number of problems including the loss of vehicle stability, load oscillation, and a decrease in visibility due to dust, leaves, etc.

Adverse factors to vehicle use are:

- Location of the work site, the aerodynamic effect of buildings, trees and other structures influence wind speed.
- The height of the extended boom: the higher the boom is raised vertically, the higher wind speed becomes.

- Load bulk area: the more space the load occupies, the more the wind force is felt.

Strong wind

DIECI telehandlers can be used up to a wind speed of 45 Km/h, equal to 12.5 m/s (No.6 on the Beaufort scale) measured on the ground.

At 10°C temperature, wind with a speed of 32 Km/h it seems that exposed parts of the body have a temperature of 0°C. The higher you climb the faster the wind speed and the more the sensation of pressure drop increases.



WARNING

Strong wind danger

In the presence of strong winds (no.5 Beaufort scale) never lift loads with surfaces exceeding 1 m².

Below you can find the graph of the Beaufort scale for an indication of the wind speed with which you are working and when to suspend operations, if wind speed should exceed determined values.

Beaufort Wind Scale			
No.	Definition	Indicators	Speed (m/s)
0	Calm	Smoke rises vertically	0 - 0,2
1	Light air	Smoke drift wind direction	0.3 - 1,5
2	Light breeze	Wind felt on exposed skin. Leaves rustle; vanes begin to move	1.6 - 3
3	Gentle breeze	Leaves and small twigs constantly moving; light flags extended	3 - 5
4	Moderate breeze	Dust and loose paper raised. Small branches begin to move	5 - 8
5	Fresh breeze	Small trees in leaf begin to sway; glassy water, small waves form	8 - 11
6	Strong breeze	Large branches in motion. Whistling heard in electrical cables. Umbrella use becomes difficult	11 - 14
7	Strong wind	Whole trees in motion. Effort needed to walk against the wind	14 - 17
8	Fresh gale	Some twigs broken from trees. Cars veer on road	17 - 21
9	Strong gale	Slight damage to buildings (falling chimneys and tiles)	21 - 24

4.9 - Assessing the consistency of the work ground

The ground on which the vehicle can be positioned must be able to support the vehicle and its maximum bearing capacity.



DANGER

Danger of tipping

The sinking of the vehicle base support may cause the vehicle tilting.



ATTENTION

Contact a qualified technician to assess the consistency of the ground according to the regulations in the country of use of the vehicle.

Request in any case the advice of a qualified technician to know whether in the workplace, there are hidden cavities (pipes, wells, old tanks, basements, manure, etc...).



NOTE

Refer to the "Technical data" chapter in the manual of the vehicle, to know the maximum load that each wheel or outrigger (if any) can apply on the ground while using the vehicle.

4.10 - Moving safely



NOTE

The following operations are standard for any type of installed equipment; however, refer to any warnings present in the equipment manual.



WARNING

In the event of scarce visibility, have a person operate on the ground for signaling.



WARNING

Do not lift or lower the loads when the vehicle is in motion.

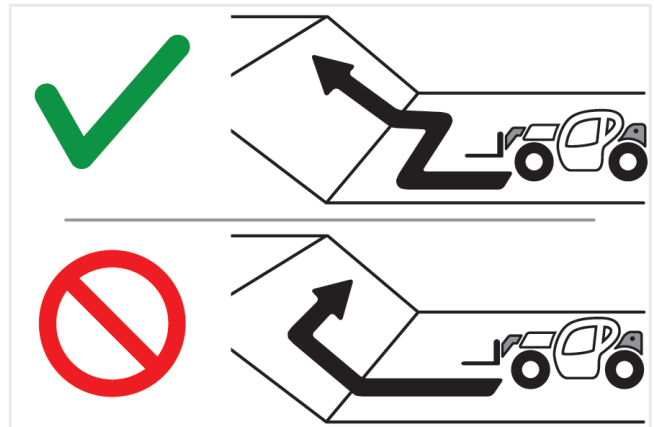

Figure: 150533-1

Operating on sloped terrain can cause overturning or sliding. Move forward and brake gradually and take all necessary cautions.

Always move in a straight line to go up or down a slope. Moving transversally or along the slope is extremely dangerous (fig. 150533-1).

Always use the parking brake when setting down or lifting a load on a slope.



WARNING

Check the vehicle is leveled before using the boom on sloped ground.

Do not stop and leave the vehicle parked on a slope exceeding 15%, even with the parking brake engaged.

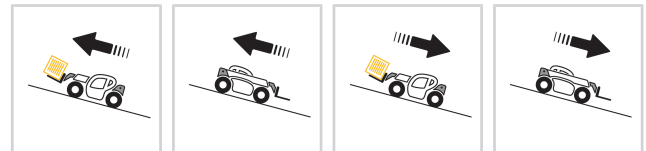

150534-1

150534-2

150534-3

150534-4

- In the event of having to travel uphill while transporting a load, operate always maintaining the load towards the top of the uphill (fig. 150534-1).
- When having to drive uphill without a load, operate with the vehicle facing downhill (fig. 150434-2).
- In the event of having to travel downhill while transporting a load, operate always maintaining the load towards the top of the uphill (fig. 150434-3).
- When having to drive downhill without a load, operate with the vehicle facing downhill (fig. 150534-4).

4.11 - General warnings for moving the load

Always adhere to safety regulations; always transport balanced, properly arranged load to prevent the risk of tipping.



ATTENTION

It is strictly prohibited to work without the respective load charts for the equipment and the vehicle.

When using this vehicle, carefully follow the load charts of the vehicle with the equipment mounted at that moment.

Do not attempt to carry out operations which exceed the capacity of the assembled equipment or of the vehicle.

Do not modify the structure and vehicle stability in any way by trying to add counterweights, whichever artifice is used.

Always ensure the pallet, the boxes and other supports for the load are in good conditions and adequate to the load to be lifted; the sudden collapse of a rack of material is often caused by a faulty pallet.

Do not move the load with boom lifted or extended.

- Handle the vehicle with the boom raised only in exceptional circumstances. In these circumstances, operate with due prudence, reduce speed as much as possible and brake delicately. Make sure that visibility is always sufficient and ask an operator on the ground to guide you for the operations.
- Reduce the speed as much as possible and brake gently during handling operations.



WARNING

Do not handle loads while the vehicle is moving.

Avoid passing over unstable objects. Remove dangerous, unstable objects instead of passing over or around them. Also avoid holes and ditches that might make the load jolt.

Before turning, slow down as much as possible, and monitor the load.

Do not change direction abruptly or at high speed.

Remember that hydraulic steering is very sensitive to steering wheel movements; steer gradually and avoid sudden movements.

Slow down before turning.

Pay attention to the side space, in particular if transporting wide loads. If possible, keep to the center of the passage to avoid equipment or personnel from obstructing your path.



WARNING

Handle loads with care, at low speed and without sudden or jolting movements, above all if they are carried at great heights.

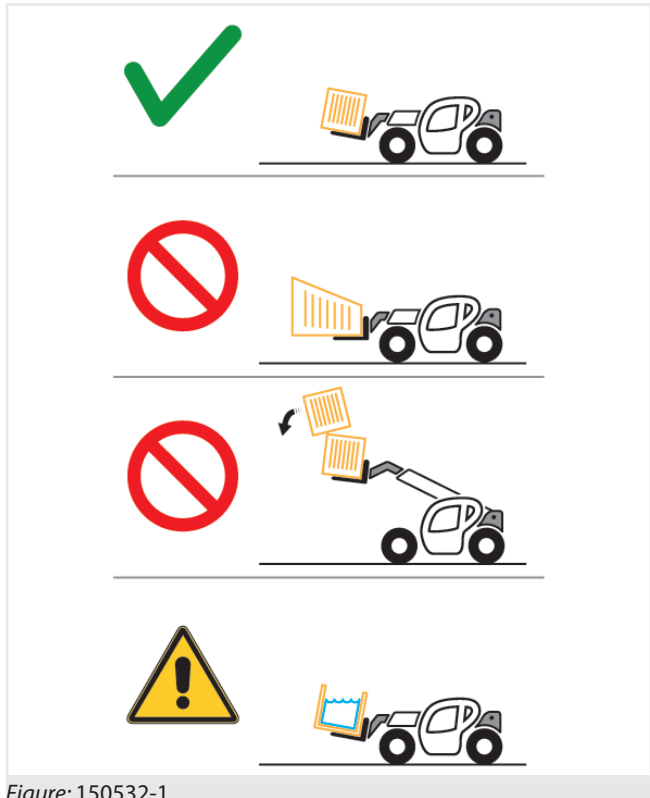

Figure: 150532-1

- Always ensure good visibility in the work area, including direct vision and visibility using wing mirrors in order to check for the presence of people, animals, obstacles, holes and changes in slope etc.
- Decrease the working speed of the vehicle in case of rain, fog, snow or in any case where visibility is reduced.
- If visibility on the right side is limited during boom operation, before lifting the load, ensure that the work area is clear and make note of the position of any possible obstacles and irregularities in the terrain.
- Always make sure there is good visibility (clean windows, clean mirrors, clean lights that work properly, etc.).
- Maintain control of the vehicle and its speed in all circumstances. The speed of the loaded vehicle must never exceed 10.0 Km/h (6.21 mph). If the

load exceeds the maximum allowed load by 50%, vehicle speed must be reduced to 5.0 Km/h (3.11 mph).

- Do not drive in reverse for long distances.
- Brake gradually; avoid braking abruptly.
- Always maintain the safe distance from other vehicles in order to have sufficient space to brake in every condition.



ATTENTION

Before lifting loads, operators must be familiar with the weight of the load and its center of gravity.

- Transport the load as close as possible to the ground. Keep the load low, at a height from the ground of 300 mm. Never move with the load lifted more than necessary.
- The load diagrams are valid for centers of gravity of standard loads. For particular loads, contact your dealer.
- Pay the utmost attention during transporting of loads with variable center of gravity (e.g. Liquids). Operate with caution in order to limit such variations and to prevent the risk of vehicle overturning.
- Always ensure the moved load is correctly balanced and cannot fall on the ground. The loss of the load or part of it can entail a danger of damage to things and persons
- Pay the utmost attention to objects that may fall. Ensure there are no unstable objects on the upper part of the load.



WARNING

Never lift a load when the vehicle is on a sloped surface. When on a sloped surface, pay attention to the conditions of the ground. When working with the vehicle on a sloped surface with the load high, a jolt or a hole is sufficient to make the vehicle overturn.

Do not move the boom if the vehicle is located on terrain with a slope greater than 2° (3.5%).

4.12 - Use of cables, ropes and slings



DANGER

It is strictly forbidden to lift or move load fastening ropes or chains only to the vehicle's attachment holding plate, to forks or to any other equipment not designed for this purpose.

Various equipment set-up for lifting, provided with suitable hooks for the use of cables, chains and straps are available. For further information contact your Dieci dealer.

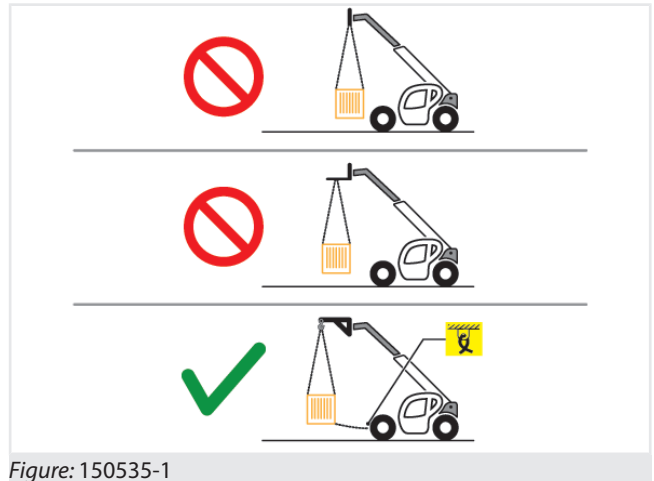

Figure: 150535-1

To keep the suspended load from swaying while being handled, the load can be fixed to the anchoring eyebolts of the vehicle while being transported.

4.13 - Road travel

4.13.1 - Road travel warnings



ATTENTION

Before starting the road travel make sure to observe the relevant laws and regulations in the country of use.

The road travel requirements are shown on the Vehicle Registration Document.

Low beam lights must be on even during the day and in streets where there is no obligation to use visual and lighting signaling devices.

Ensure correct operation and cleaning of headlights, direction lights and windscreen wipers.



WARNING

Check the correct position of the wing mirrors.

The objects seen through the wing mirror are closer than they appear.

When driving on the road and/or on a slope it is necessary to be very careful to the engine rpm. A high number of rpm can lead to mechanical failures. Keep under control the engine rpm and speed.

Pay particular attention to loading docks, trenches, scaffolding and land recently excavated or filled

4.13.2 - Road travel instructions

- Level the vehicle so that the wheel axles are aligned with the chassis (if present).
- Ensure that all outriggers have been perfectly retracted and raised (if present).
- Close the telescopic arm (boom) completely.
- Lower the telescopic boom completely and then raise it slightly to about 20-30 cm from the ground.
- Check the correct operation of the lights before moving on roads. Check that the rotating light for slow vehicle signaling is installed and running; keep the rotating light in operation both at day and at night.
- Perform the wheels alignment, so that they are perfectly aligned with the vehicle chassis.
- **It is mandatory** to arrange the steering as reported in the Vehicle Registration Document and lock the selector lever with the dedicated device.
- Make sure that the amount of fuel is sufficient.
- Assemble all the accessories required for road circulation depending on the country in which the vehicle is operating.
- Install an overhanging load signal panel on the boom head before the entering onto the road.
- Always evaluate the road to be traveled, taking account of suspended structures (e.g. bridges, underpasses, etc.) that could be damaged by the vehicle.
- In some countries it is mandatory to place wheel chocks under the tires when the vehicle is stopped.
- Make sure that your vehicle is in compliance with local legislation in reference to the presence of the license plate when traveling on the road both at day and at night.



WARNING

Road transfer with equipment assembled to the fork holding plate is not allowed except those accepted by the legal authority of the country where the vehicle operates.



WARNING

It is not allowed to travel on public roads with loaded vehicle.

Comply with the maximum permissible mass written on the vehicle registration document.

4.14 - Momentary stop



ATTENTION

If it is necessary to leave the driving position, follow the steps in the "Parking the vehicle" paragraph.



WARNING

Never move away from the vehicle, leaving the engine running or the ignition key on the vehicle.



WARNING

Do not stop and leave the vehicle parked on a slope exceeding 15%, even with the parking brake engaged.

- Gradually release the accelerator pedal.
- Stop the vehicle on even ground.
- Engage the parking brake
- Bring the movement selection lever to "N".
- During the running-in of the vehicle (50 h), do not keep the diesel engine at minimum revs for too long.

4.15 - Parking the vehicle

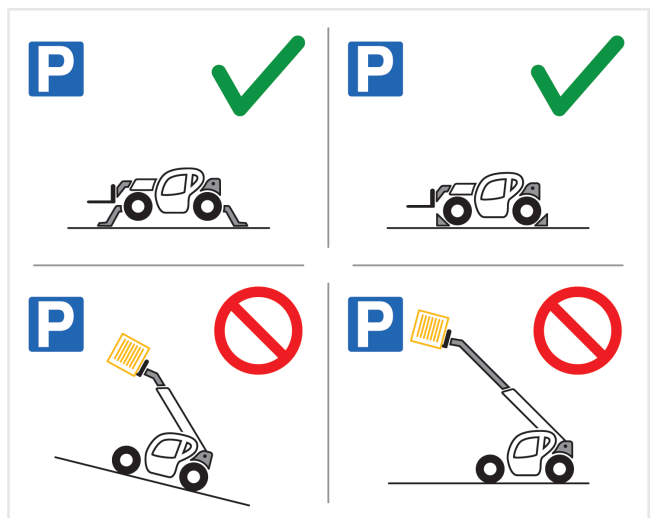



Figure: 150536-1

Never leave in any case the vehicle parked with a raised load.

- Always park on flat, firm and level ground, where there is no risk of falling rocks, landslides or flooding.
- Lower outriggers to the ground (if present).
- Retract the boom completely and lower it to the ground.
- Engage the parking brake
- Bring the movement selection lever to "N".
- Run the engine at idle speed for some seconds before turning it off, in order to allow the engine cooling.
- Turn the ignition key to the engine stop position.
- Remove the key from the ignition switch.
- Lock the hydraulic controls with the special devices (if present).
- Close the windows and lock them with the handles.
- Close the cab door by key.
- Place wedges under the wheels.
- Make sure that the vehicle is parked so as not to impede its movement and at least 5 meters away from the railroad tracks.

 **WARNING**
Do not stop and leave the vehicle parked on a slope exceeding 15%, even with the parking brake engaged.

4.16 - Starting and stopping the vehicle

4.16.1 - General warnings regarding starting up the vehicle

 **WARNING**

Do not use the vehicle without having first read and understood all parts of this manual, and without having attended an adequate training course.

- Before starting the engine, make sure all control levers are in a neutral position, the parking brake is engaged, the engine hood is closed and that there is nobody in the area surrounding the vehicle.
- The vehicle can only be started up or maneuvered when the operator is seated in the driver's seat, with the seat belt fastened and adjusted.
- The vehicle may move suddenly if started up without following the correct procedure, thus, creating the risk of damage.
- Never start the engine by causing a short circuit between the terminals of the starter motor.
- Never start-up the engine by pushing or pulling the vehicle. This could seriously harm people or cause serious damage to the vehicle.
- Be careful when using auxiliary batteries as the gas contained in these may explode, causing serious damage. Follow the instructions provided in the "Emergency procedures" chapter, "Start-up using auxiliary batteries" paragraph to start the engine using auxiliary batteries. An incorrect procedure can cause serious damage to the electrical/electronic system, the vehicle could move suddenly, the battery could explode and damage could be caused to objects and/or people.
- Do not start the engine or touch the levers of the vehicle if a danger sticker or a maintenance in progress sign is placed inside the cab.

4.16.2 - Inspections prior to starting-up

4.16.2.1 - Inspecting the vehicle

Carefully inspect your vehicle every day or before every shift.

Carry out the following inspections and operating checks:

- Parking brake efficiency
- Intact condition of the tires
- Type of tire suitable for the type of work ground
- Engine oil level (check and top-up, if necessary)
- Hydraulic oil level (check and top-up, if necessary)
- Air filter clogging indicator (check and clean, if necessary)
- Tire inflation and pressure (check)
- Fuel level (check)
- Signaling and warning devices (check)
- Steering efficiency
- Service brake efficiency
- Tightness of all nuts and bolts
- Lighting
- Direction indicators
- Emergency Lights
- Switches
- Indicator lights
- Windscreen wipers
- Reverse buzzer/alarm
- Position and condition of wing mirrors



DANGER

Immediately stop using the vehicle in case of malfunctions or if it does not comply with safety standards.

Contact an authorized *Dieci s.r.l.* workshop if the vehicle shows malfunctions. Refer to the "Maintenance" chapter for information regarding routine maintenance.



NOTE

A thorough inspection is required if the vehicle is not used for a prolonged period of time. A detailed description of the operations is provided in the "Vehicle storage" chapter

4.16.2.2 - Inspecting the work area

- Examine the work area when working at the edge of an excavation or on soft ground as the vehicle could overturn.
- Examine the conformation and condition of the terrain of the work area before beginning to operate.

- Keep the vehicle well away from the edge of the excavation and the side of the road.
- When working on a slope or near the roadside, have another person present for signaling.
- Pay utmost attention when working on icy ground. The ice will melt as the temperature rises and the ground will become slippery.
- Check for any overhead electrical lines or underground pipes.
- Do not work in places at risk of landslides or falling rocks.
- Take due precautions to prevent any unauthorized persons from entering the working area.
- When moving through or operating in shallow water or soft ground, verify the shape and the conditions of the land, the water depth and flow rate before beginning the operation.

4.16.3 - Starting-up the engine

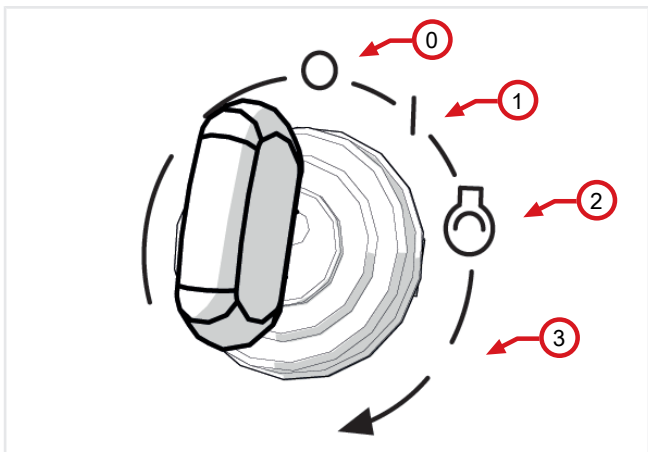

Figure: 150538-1

Proceed as follows to start-up the engine of the vehicle:

1. Press the parking brake switch.
2. Bring the movement selection lever to neutral.
3. Remain seated in the driver's seat.
4. Turn the ignition key (fig. 150538-1) clockwise to position "1".



WARNING

Wait for 1 second before turning the key to position "2", for correct operation of the control unit

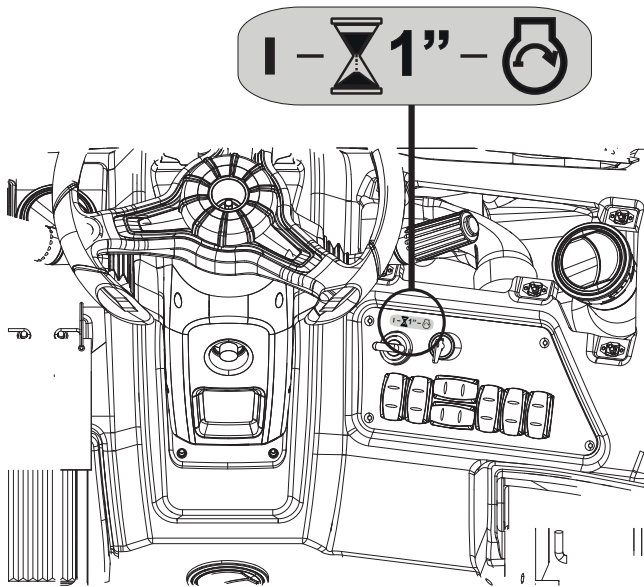

With the key in this position:

- The control panel and dashboard will be powered
- An audible warning device will be activated, indicating that the key has been inserted. This audible warning device also serves to warn any persons in the surrounding area that the vehicle has been started up.
- A check-up of the instrumentation will be performed with all the indicators lighting up for about 5 seconds. Only the following lights must remain switched on at the end of the check-up:
 - Engine oil pressure warning light
 - Battery charge indicator light
 - General alarm warning light
 - Intermittent buzzer
 - Other indicators of activated functions (e.g.: Parking brake, gears engaged, etc.)

WARNING! If other indicators remain on signalling malfunctions or if one of the previous conditions does not occur, do NOT start-up the engine and refer to the "Maintenance" chapter or contact the Dieci service centre.

- Turn the ignition key (fig. 150538-1) to position "3" to start-up the engine. Release the starter within 5 seconds.
- Release the key once the engine has started. The indicators related to the engine oil pressure and battery charge must go off once the engine is started up.
- If the engine does not start within 5 seconds, try again at regular 15 second intervals to prevent overloading the starter motor.

4.16.4 - Warm-up after starting-up

During the first few minutes of use, keep the speed slow in order to warm up the engine and hydraulic oil.



WARNING

Serious damage can be caused to the engine and the hydraulic system if the engine reaches high rpm before the operating oil temperature and pressure levels are reached.

Let the engine run at 1100 - 1300 rpm for about 5 minutes so as to bring the engine oil to the operating temperature, particularly, with outdoor temperatures below 0 °C.

4.16.5 - Start-up at low environmental temperatures

Consider the following warnings before starting-up at low environmental temperatures and with a cold engine:

- In order to prevent discharging the battery, do not prolong each attempt to start-up by more than 15 seconds; however, if the engine does not seem to be starting-up, extend the time to a maximum of 30 seconds.
- Wait at least one minute before trying to start-up again.
- It is recommended to not exceed six start-up attempts so as not to discharge the battery excessively.



NOTE

It is recommended to use anti-freeze diesel at environmental temperatures lower than 0°C, so as to make sure the engine is optimally supplied, without reducing performance.

4.16.6 - Causes of failed start-ups

Check the following if the engine does not start-up:

- The parking brake switch is pressed.
- The gear selection lever is in the neutral position.
- No emergency stop buttons are pressed.

After checking all the previous conditions, remove the cause of failure to start and try the starting procedure again.

**NOTE**

If the problem persists, contact a *Dieci* after-sales center.

4.16.7 - Turn off the vehicle

It is recommended to perform the following before switching the engine off:

1. Bring all the control levers to the idle position.
2. Bring the engine to low speed for a few seconds.
3. Turn the ignition key to position "0".

**NOTE**

The images used to describe components and controls refer to a complete vehicle with all accessories; these may vary depending on the attachments and on the configuration chosen.

Refer to the "Definitions" manual to understand references such as: Right side, Left side, Front and Back used in the manual.

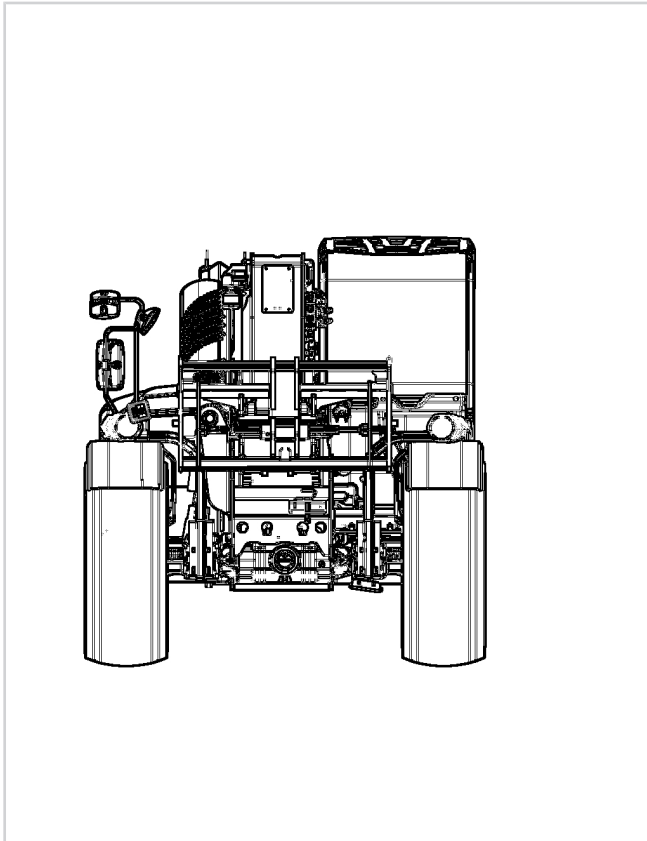
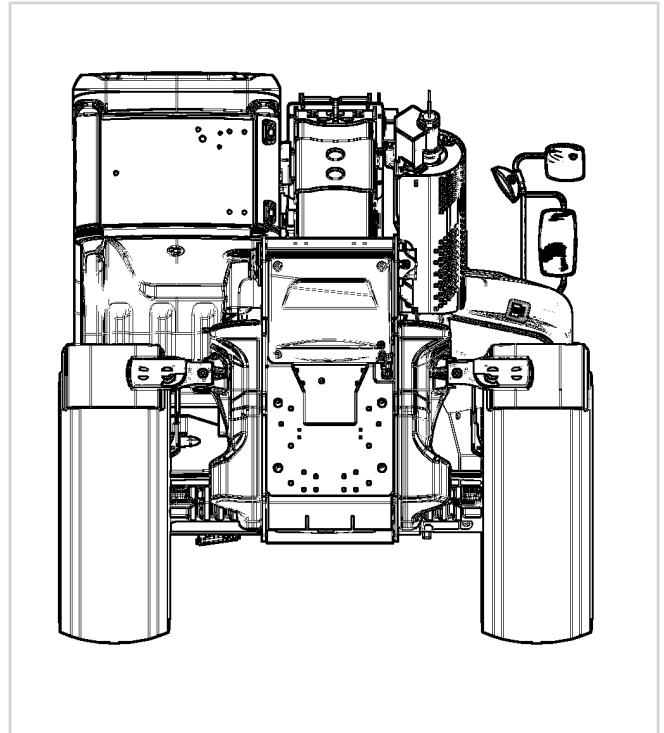
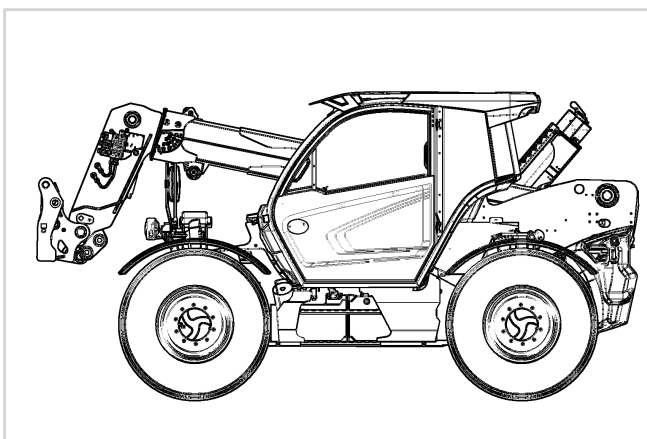
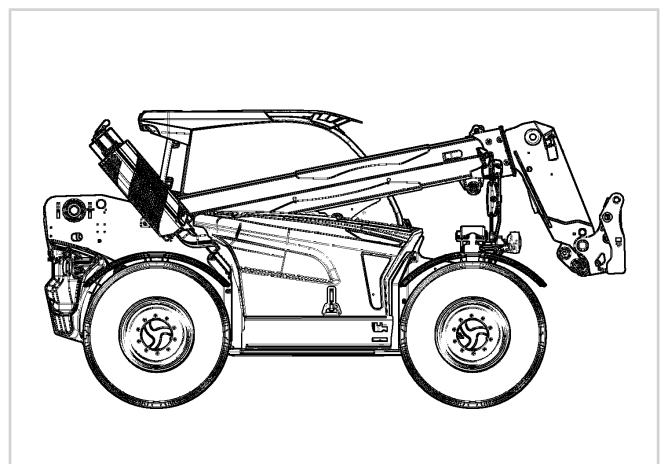
*150641-1: Front view**150641-2: Rear view**150641-3: Left view**150641-4: Right view*

5.1 - Left side components description

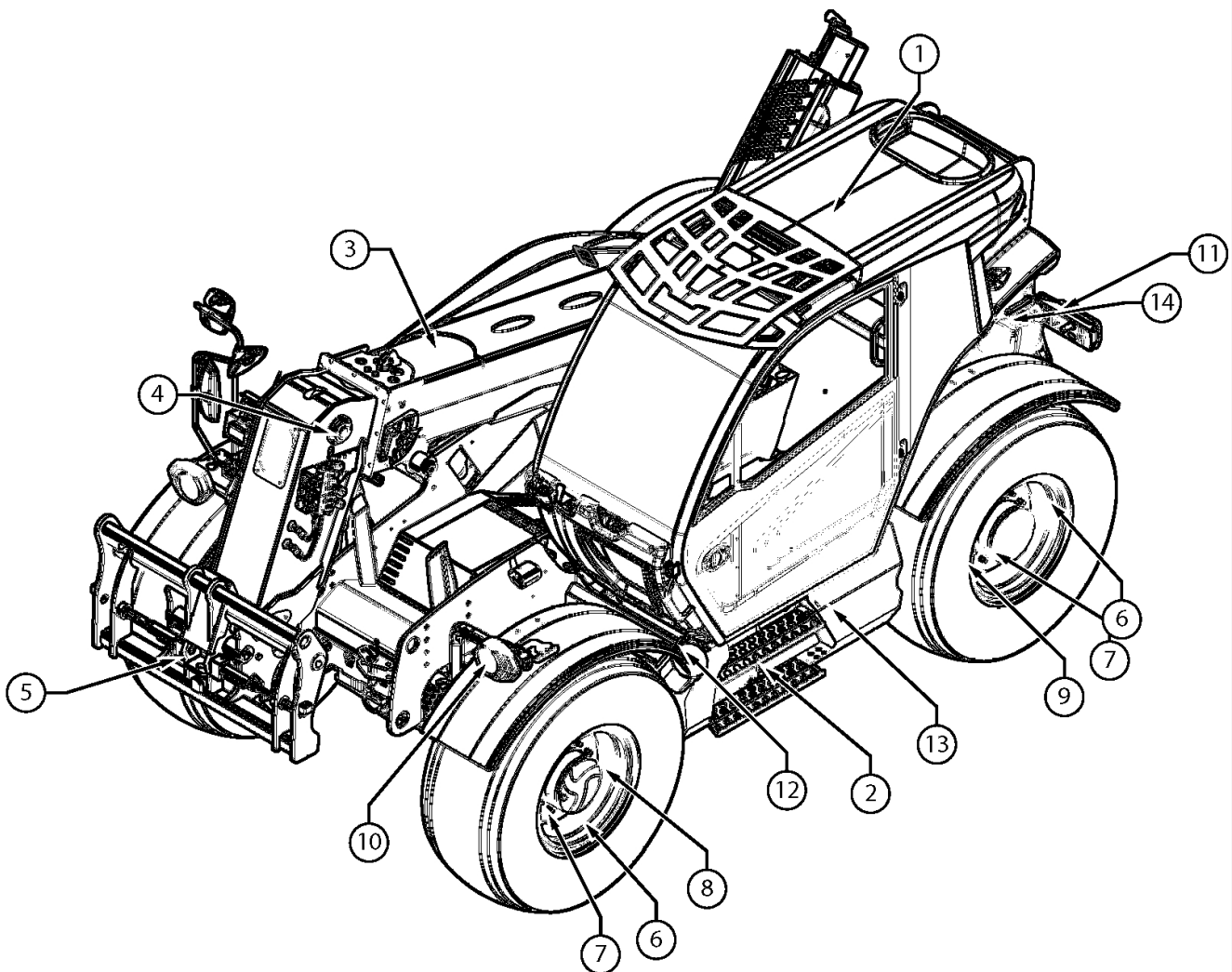

Figure: 150643-1: Left side view

1 Cab	2 Steps for climbing on
3 Telescopic boom	4 Boom head
5 Attachment holding plate	6 Wheel
7 Epicycloidal reduction gear	8 Front axle
9 Rear axle	10 Left front headlight
11 Left rear headlight	12 Fuel tank
13 Oil tank	14 AdBlue tank

5.2 - Right side components description

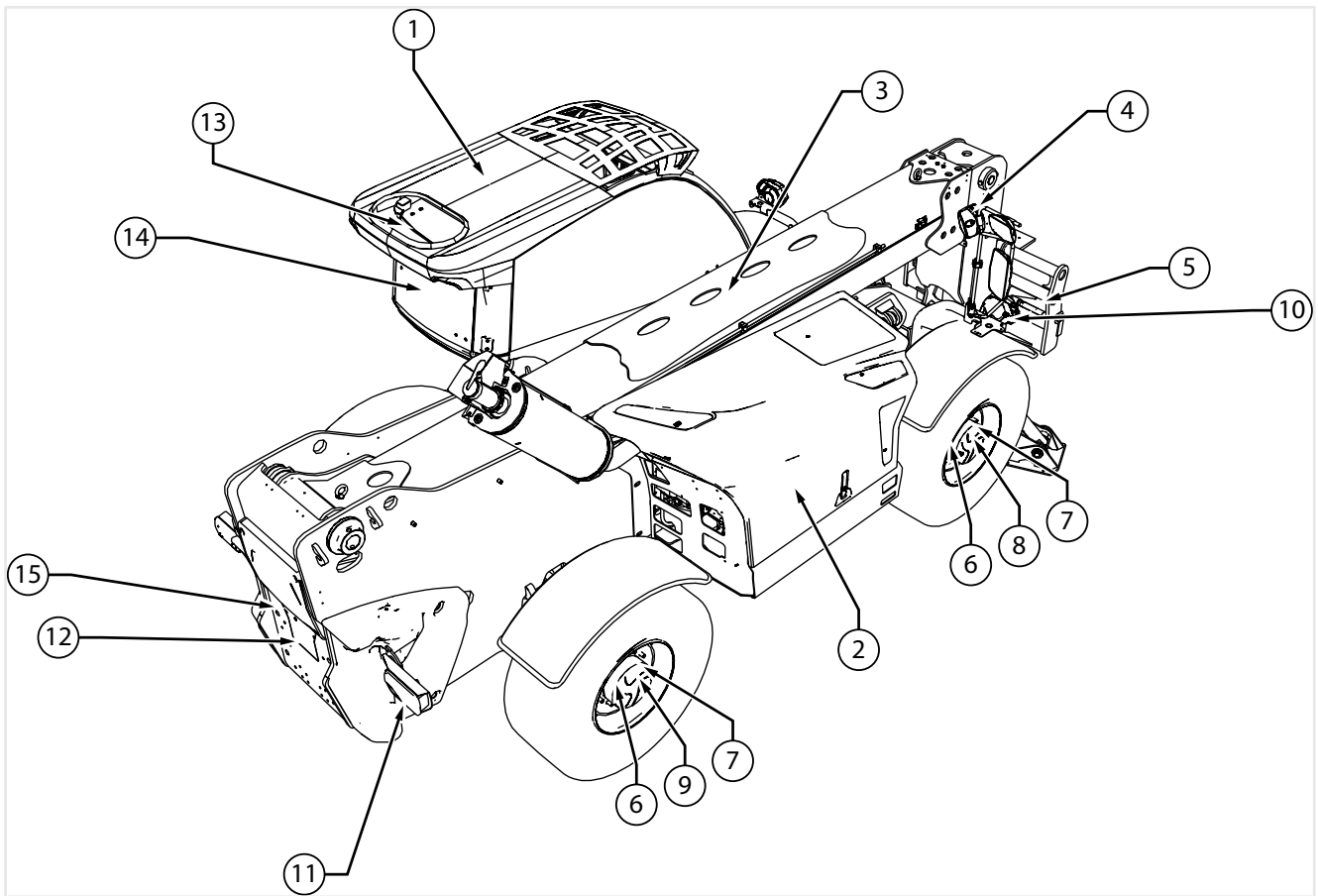

Figure: 150644-1: Right side view

1 Cab	2 Engine hood
3 Telescopic boom	4 Boom head
5 Attachment holding plate	6 Wheel
7 Epicycloidal reduction gear	8 Front axle
9 Rear axle	10 Right front headlight
11 Right rear headlight	12 Battery
13 Air conditioned (optional)	14 Rear emergency exit
15 Rear hydraulic sockets (Optional)	

5.3 - Engine components description

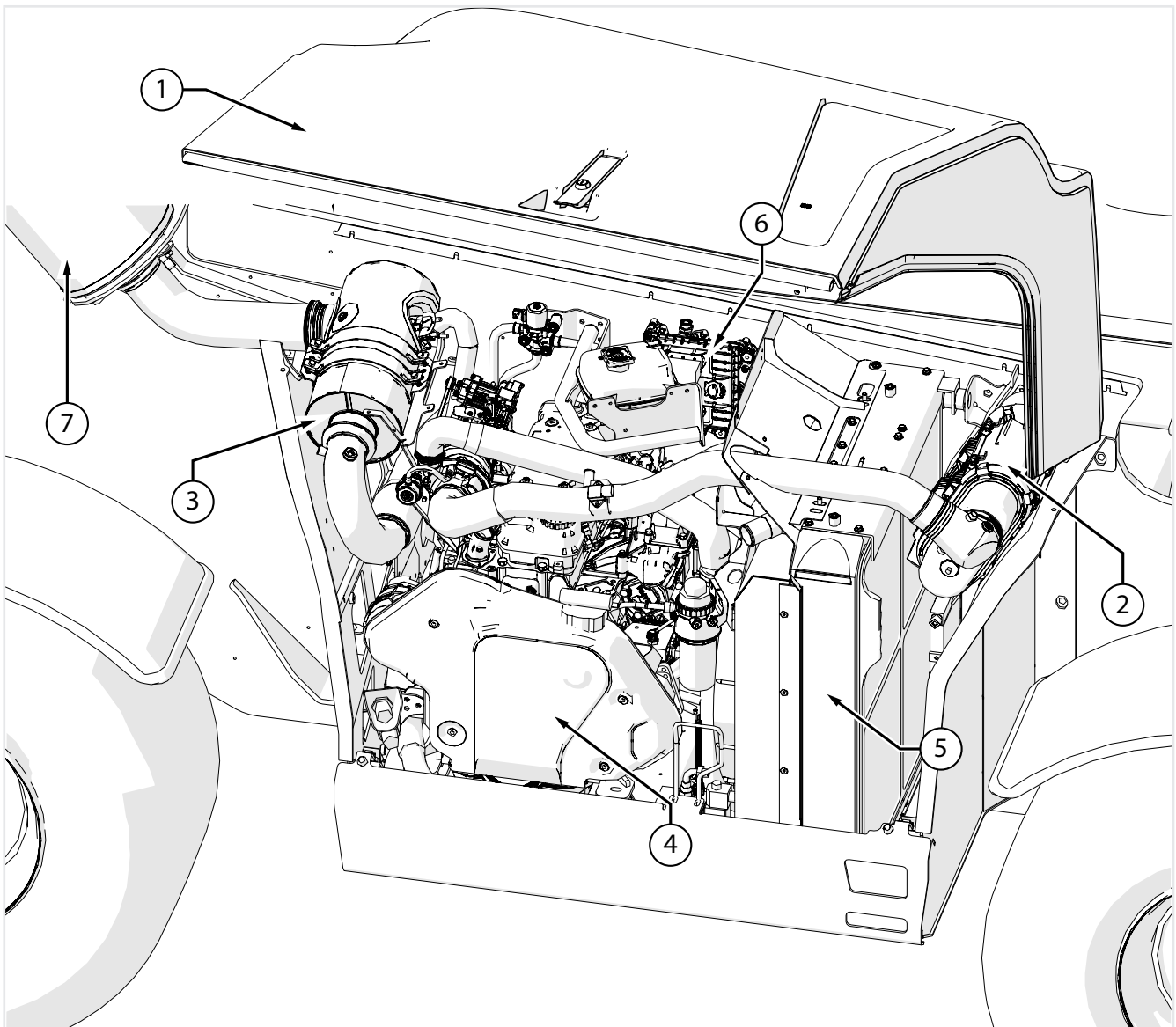

Figure: Engine view

1 Engine hood	2 Air filter
3 DOC	4 Engine
5 Radiator	6 Engine control unit
7 SCRof and CUC	

5.4 - Cab description

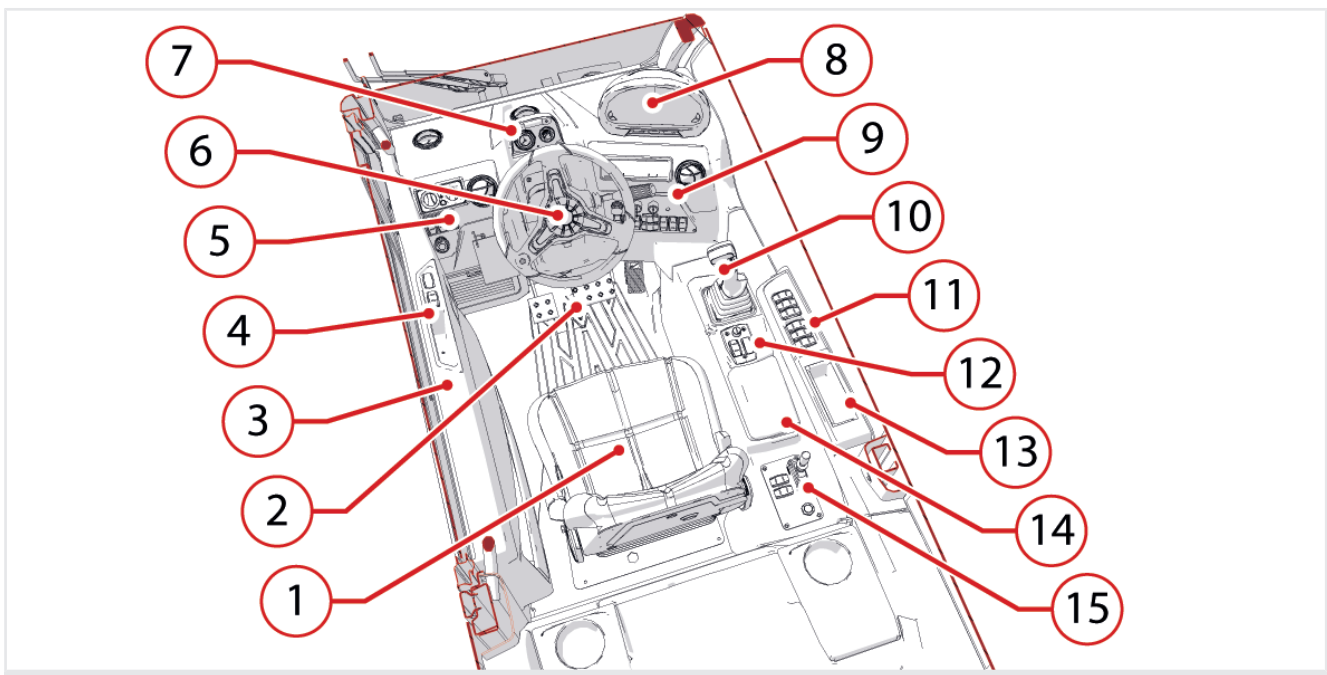

Figure: 180336-1

1 Seat	2 Pedals
3 Door	4 Door controls
5 Left instrument panel	6 Steering wheel
7 Central instrument panel	8 Right instrument panel
9 Right instrument panel	10 Joystick
11 R/H high instrument panel	12 Hydraulic sockets selector (if present)
13 Storage compartment	14 Armrest
15 Steering selector lever	

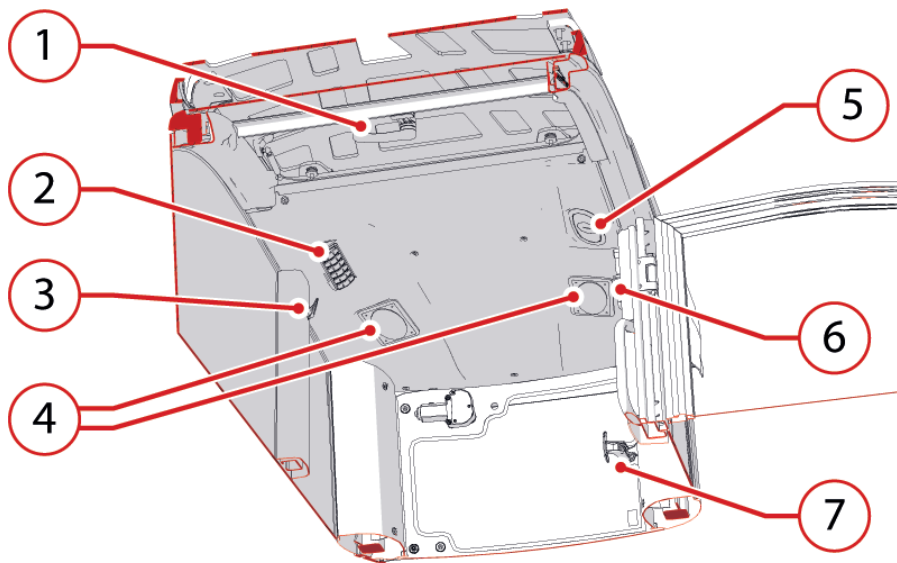

Figure: 180337-1

- | | |
|---------------------|--------------------------------|
| 1 Sunroof | 2 Instrument panel on the roof |
| 3 Clothes hanger | 4 Stereo speakers (if present) |
| 5 Interior lighting | 6 Hammer for emergency exit |
| 7 Rear glass handle | |

6.1 - List of safety devices

Safety devices	Additional information	
Safety devices	7.1	ROPS - FOPS Cab
	7.3.1	Emergency stop
	7.3.3	Safety rod
	7.3.4	Wheel wedge
	7.3.5	Block valves
	7.3.6	Emergency exit: Rear glass
	7.3.7	Emergency exit: Front glass *
	7.5.1	Emergency Lights
	7.6.1	Deadman seat sensor
	7.6.3	Seat belts
	7.11.1	Load Charts

6.2 - Safety stickers

6.2.1 - Warnings for safety stickers

Some safety stickers have been applied on the vehicle and equipment in the positions shown below. Their purpose is to provide a guide for your own and others safety. Before starting to work, check the content and location of the stickers indicated on this manual. Review the safety stickers with all operators who will use the vehicle and equipment.



ATTENTION

Make sure to have fully understood their correct location and their contents.

To ensure proper interpretation verify that they are in the correct position and that they are always kept clean.



DANGER

Clean them when they are covered by mud, concrete or debris.

It is absolutely forbidden to clean the stickers using solvents or gasoline; the labels may become discolored.

See the summary table in the "Maintenance" chapter for the for safety stickers maintenance and control deadlines.

Replace the safety stickers in case of deterioration, damage or loss, as these must always be read and interpreted correctly.



WARNING



Do not under any circumstances remove the safety stickers.





NOTE







The purchase order of replacement safety stickers must be made in the same way in which any spare part is ordered (be sure to communicate the model and serial number of the vehicle or equipment when placing the order).

6.2.2 - Meaning of safety stickers

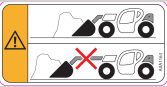
SIGNAL	CODE	DESCRIPTION
	AXA1428	Indicates the tyre pressure
	AXA1808	Indicates the maximum guaranteed acoustic power
	AXA2227	Tyres maximum load on the ground (R.max daN=) 10000

Decals on vehicles for the agricultural sector

SIGNAL	CODE	DESCRIPTION
	AXA2111	Risk of being trapped in the moving parts in the vicinity of the PTO
	AXA2419	Break the glass with the hammer in case of emergency

SIGNAL	CODE	DESCRIPTION
	AXA1163	Warning, keep the boom fully retracted when digging with buckets.
	DOCAD0000053	Danger, stop the engine and remove the ignition key during maintenance operations
	DOCAD0000054	Danger, comply with the safety distances from electric lines
	DOCAD0000370	Indicates where to refuel
	DOCAD0000371	Indicates the type of fuel
	AXA1431	Indicates the lifting points
	AXA1432	Indicates the points at which to anchor the vehicle for transport or towing

SIGNAL	CODE	DESCRIPTION
	DOCAD0000090	Position of the hitch for vehicle towing.
	AXA1433	Indicates where to check the hydraulic oil level
	AXA1434	Indicates where refueling hydraulic oil
	AXA1435	Danger, moving mechanical parts, do not remove the safety guards and wait that the parts have stopped before carrying out any maintenance
	AXA1436	Indicates the position of the safety rod for lifting cylinders
	AXA1438	Indicates vehicle parts that can not be walked on
	AXA1439	Danger moving mechanical parts
	AXA1440	Danger of hot steam under pressure escaping
	AXA1441	Danger of hot surface
	AXA1492	Indicates the position of the brakes oil tank and the type of oil to use
	AXA1493	Warning, keep a safe distance
	AXA1498	Indicates the position and instructions for using the battery isolation switch
	DOCAD0000063	Battery isolation switch button instructions
	AXA1501	Indicates lubrication points
	AXA1506	Compulsory use of seat belts
	AXA1514	Emergency exit
	AXA1515	Remove the cotter pin

SIGNAL	CODE	DESCRIPTION
	AXA1773	Warning, do not reach high speeds or over-revving the engine in downhill
	AXA2089	Caution, hydraulic circuit with pressure accumulators
	AXA2103	Warning, keep a safe distance
	AXA2430	Do not stand under the forks or transport people with the forks
	DOCAD0000209	Instructions for standard joysticks
	DOCAD0000212	Instructions for joystick [PS evo2 transmissions only]
	AXA2708	Type of oil used in the standard hydraulic system
	AXA2798	Type of oil used in the hydraulic system ISO 32
	AXA1892	Indicates maximum use of the vehicle in case of wind
	AXA1437	Engine hood opening lever indication
	AXA1446	Horizontal boom indication
	AXA2748	Battery maintenance danger
	DOCAD0000049	AdBlue filling cap position
	DOCAD0000142	Indication on the required fuel quality
	DOCAD0000208	Instructions for rear hydraulic sockets [optional]
	AXA1444 *	Danger of feet crushing [Only for vehicles with outriggers]

6.2.3 - Safety stickers position on the vehicle

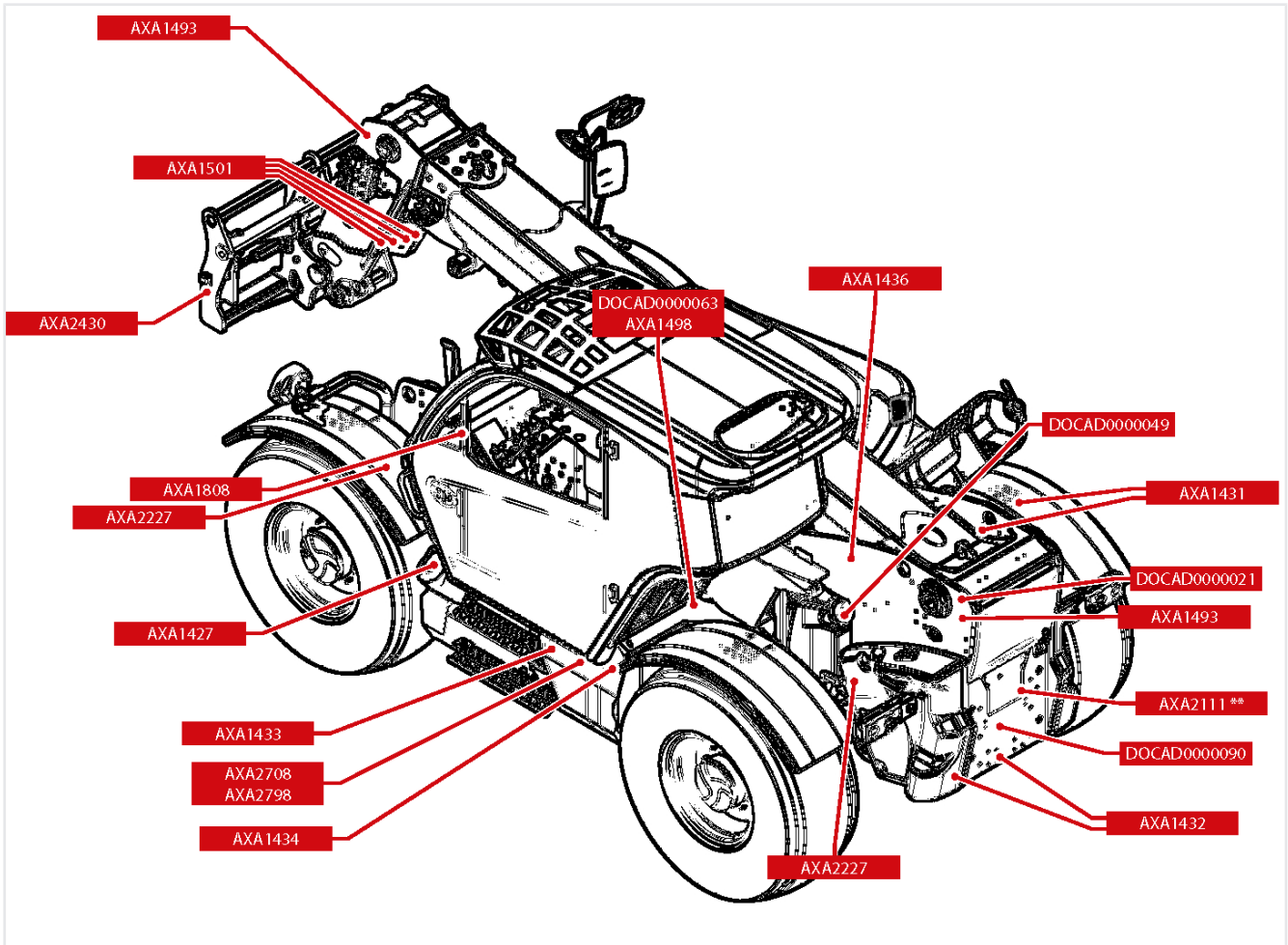

Figure: Agri Max GD - stickers position on LH side

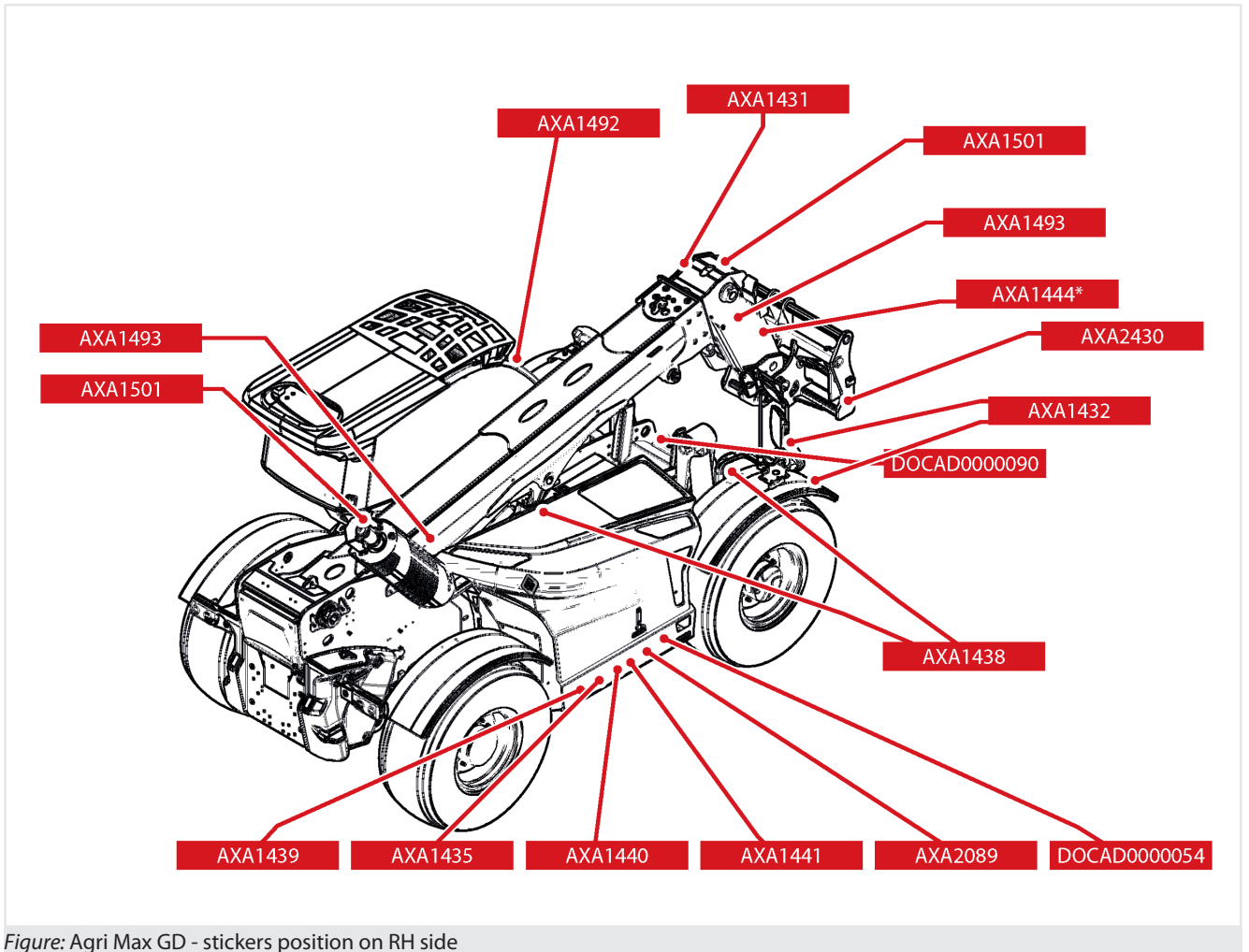

Figure: Agri Max GD - stickers position on RH side

- * Stickers present in case of outriggers
- ** Decals present for agricultural sector machines
- *** Stickers for mechanical engines

6.2.4 - Safety stickers position in the cab

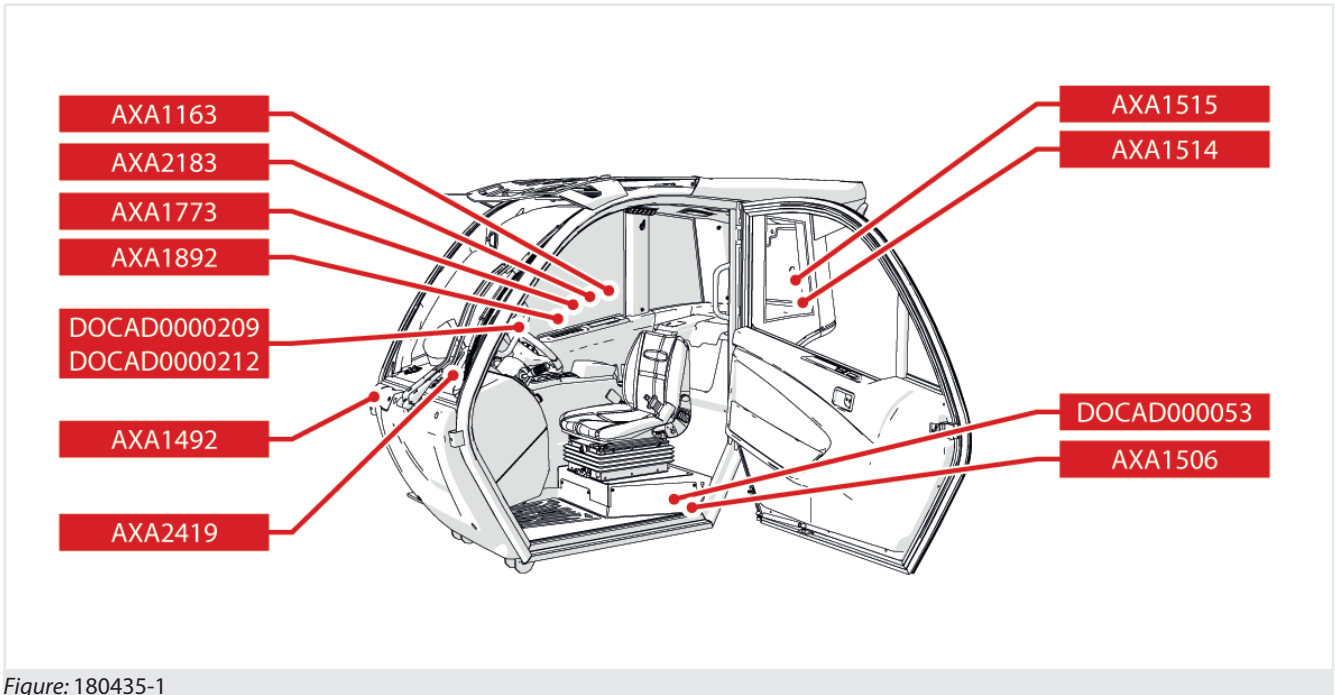

Figure: 180435-1

7.1 - ROPS - FOPS Cab

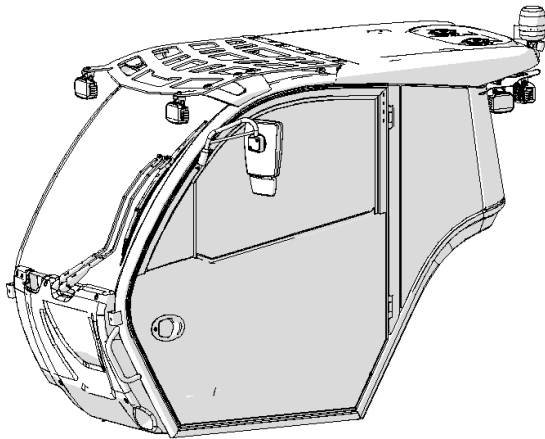

Figure: 150990-1

The vehicle is equipped with an approved cab:

- **ROPS** (Roll Over Protection Structure)
- **FOPS** (Falling Objects Protective Structure)

The operator is therefore protected in the event of vehicle tipping and in the event of falling objects, as prescribed for earth moving vehicles.



ATTENTION

The cab is a safety device and as such must be always kept in the right conditions of use.

In case of cab tampering, the manufacturer has no civil liability in case of an accident, therefore it is absolutely forbidden to:

- Change, drill, or alter in any way the structure of the cab.
- Weld or mechanically connect parts to the cab chassis.
- If the fastening bolts are replaced, use elements of different strength class.
- Connect chains or ropes to the cab for the purpose of towing.



WARNING

In the case of vehicle tipping, staying in the cab with fastened seat belts allows to obtain a better protection.

If the cab has undergone visual damage it must be replaced by consulting the authorised service centre or Dieci authorised workshop.

The cab is classified as: CATEGORY "1"

The cab approved as category "1" does not offer full protection against the ingress of dust, aerosols and vapours. Consult and follow the instructions provided by the manufacturer of the chemicals used (such as pesticides, fungicides, herbicides, etc..) and those supplied by the manufacturer of the sprayer. Use the appropriate personal protective equipment and clothing (PPE) when indicated in these instructions, even when you are inside the cab.



DANGER



Inhalation danger for operators and bystanders.

For protection against harmful dust, aerosols and vapours, refer to the instructions provided by the manufacturer of chemicals, by the manufacturer of the sprayer and to the basic rules contained in this manual.

Refer to the packaging of the product used to use the appropriate protective equipment.

7.2 - Climbing in and off the vehicle

7.2.1 - Door opening

7.2.1.1 - External door handle

The door of the cab is equipped with an external handle "1" with lock.

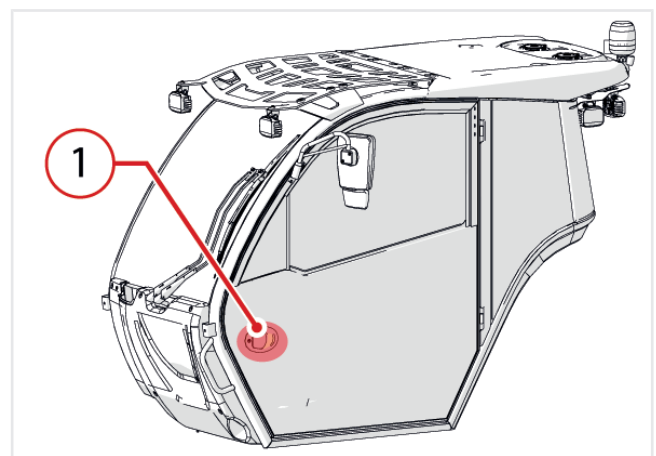

Figure: 170805-1

To open the door from the outside:

- Insert the key into the lock and turn it clockwise/ counterclockwise to engage/disengage the lock.
- Pull the handle towards yourself to release the door with lock disengaged.

**NOTE**

With lock engaged, the door will not open by the handle.

**WARNING**

It is absolutely forbidden to operate with the cab door open.

7.2.1.2 - Internal door handle

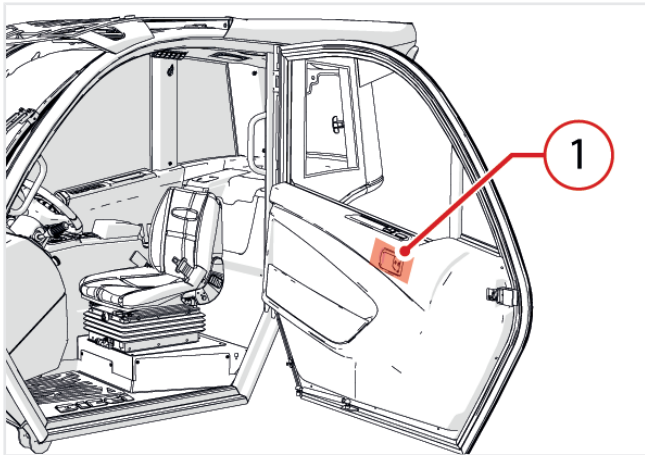

Figure: 170806-1

To open the door from the inside:

- Pull the handle to the inside to disengage the door "1".
- Push the door to the outside to complete the opening.
- Accompany the door with one hand while opening it.

**ATTENTION**

Before pushing the door outwards verify that the opening area is free from obstacles of various kinds.

7.2.2 - Climbing in/out

**NOTE**

Before climbing into the cab, make sure your hands and your shoes are clean and dry to avoid slipping and falling.

Use only the appropriate handles and steps to access the cab, do not use the controls and the steering wheel from inside. Climb in and out of the vehicle always turned towards the driver's cab.

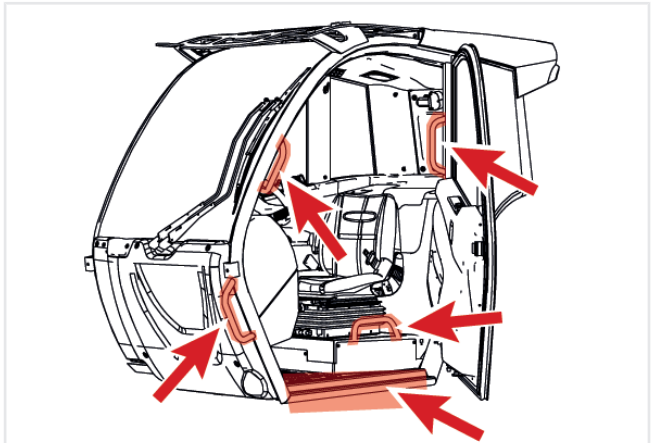

Figure: 170807-1

**WARNING****DANGER**

Climbing in and out of the cab is allowed only when the vehicle is stopped with the parking brake engaged. Do not leave the cab with the vehicle in motion.

7.3 - Safety

7.3.1 - Emergency stop



In emergency conditions, the machine can be stopped using the Emergency stop buttons.



ATTENTION

It is recommended to use the emergency stop button only in case that there is an immediate danger to the operator, to the load and/or to the integrity of the vehicle.

The pressure exerted on the emergency stop button activates the power supply cut-off and the consequent complete shutdown of the vehicle and any connected equipment.

The return to normal working conditions, after a stop caused by the emergency stop button, is only possible after:

- Removal of the cause that caused the stop
- Releasing the emergency stop button

To release the emergency stop button, rotate it in the direction indicated by the arrow printed on the button.

7.3.2 - Emergency stop lever

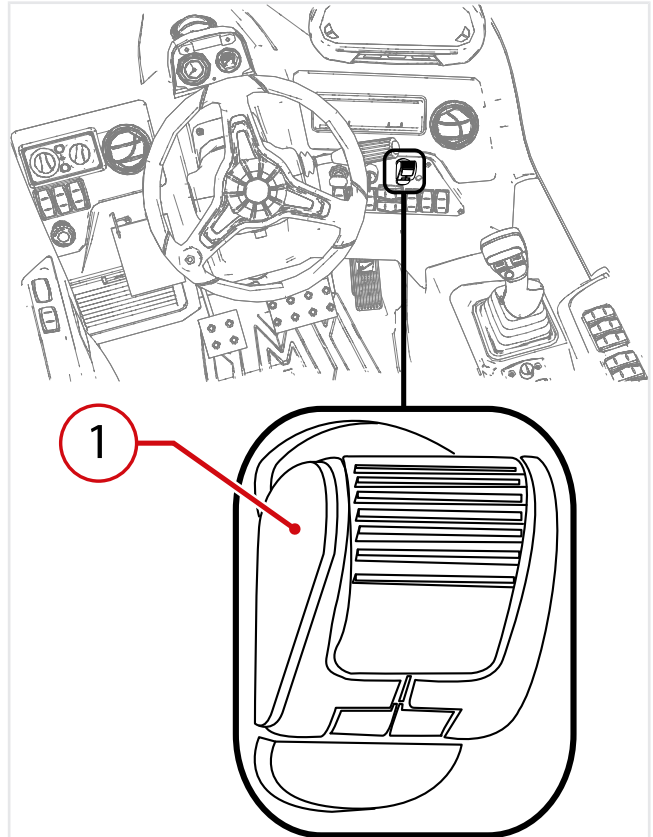

In emergency conditions, if the brake does not work, the machine can be stopped by means of the unstable emergency stop lever "1" located in the cab. Keep the lever pressed downward to let the machine be stopped smoothly.



DANGER

The stop will be gradual up to a speed of 10 Km/h; after that the machine will stop abruptly.

As the lever is unstable, at the moment of release the machine will start going at normal speed

7.3.3 - Safety rod

The safety rod must be used as a safety measure during maintenance operations, to prevent the descent or fall of the boom in case of failures.

To insert the safety rod "1" (fig. 150459-1) operate as follows:

- Lay a load on the ground
- Completely close the extensions of the telescopic boom
- Lift the boom to the minimum height necessary to apply the safety rod

- Apply the safety rod around the lifting cylinder rod

Lock the safety rod by means of the appropriate hooks "2".

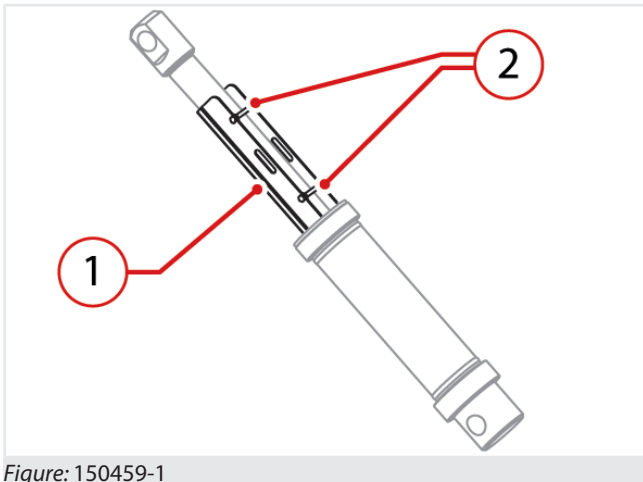

Figure: 150459-1



WARNING

DANGER OF CRUSHING

In case of maintenance to the boom lifting cylinder or the relative block valve it is required to support the boom by means of an appropriate lifting device with minimum capacity of at least 3000 kg (6613.87 lb).

7.3.4 - Wheel wedge

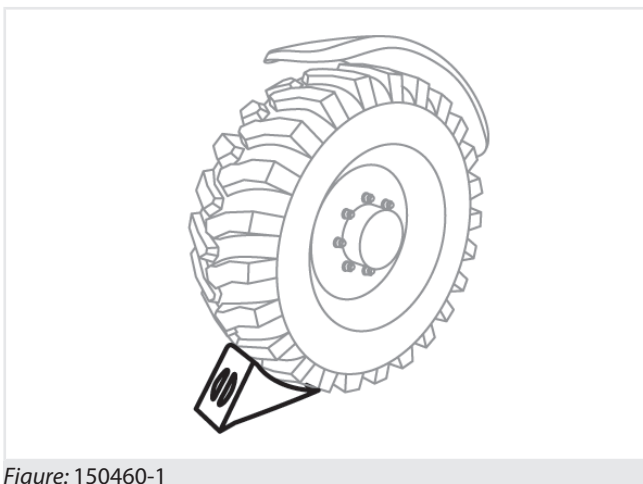

Figure: 150460-1

The wheel wedge (fig. 150460-1) must be used as a safety measure to prevent accidental or unwanted movements of the vehicle.

It is advisable to use them when parking the vehicle during stops along slopes or during maintenance operations.

7.3.5 - Block valves

The block valves (fig. 150461-1) for cylinders prevent uncontrolled movement of the pistons of the cylinders in the event of hydraulic pressure failure or bursting of a flexible pipe.

The valves are installed directly on all the cylinders.

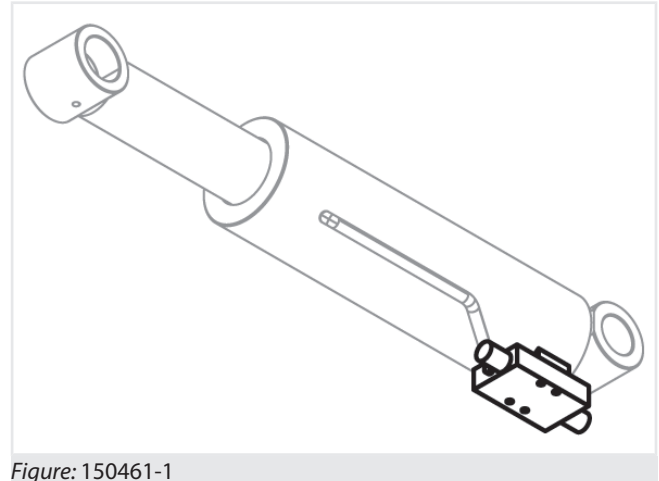

Figure: 150461-1

7.3.6 - Emergency exit: Rear glass

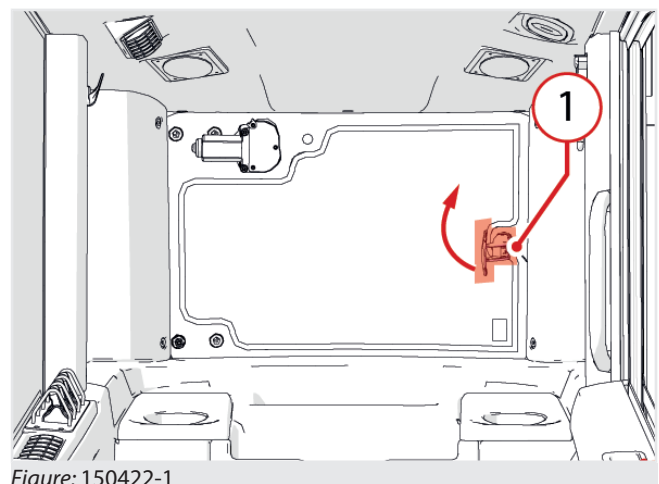

Figure: 150422-1

The rear glass of the cab (fig. 150422-1) can be used as an emergency exit in case the vehicle doors are locked.

To open the window fully, slide the fastener to "1" and push the glass outward.

The fastener must always be positioned as shown in the figure during normal work operations.



DANGER

Danger of crushing.

It is prohibited to fully open the glass during the use of the vehicle, because of the shearing risks between the boom and the chassis.

The rear glass is near the telescopic boom.



WARNING

Be very careful when opening and/or removing the glass, as this may chip or crush and may cause injury to the operator in the cab and to who is near the vehicle.

7.3.7 - Emergency exit: Front glass *



NOTE

* **Emergency exit: The front glass is an optional attachment.**

Emergency exit: The front glass is a standard attachment for the vehicles approved as agricultural tractors.

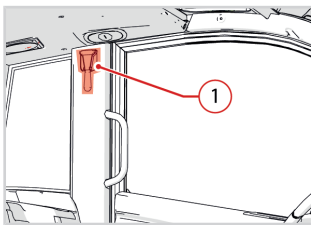

150423-1

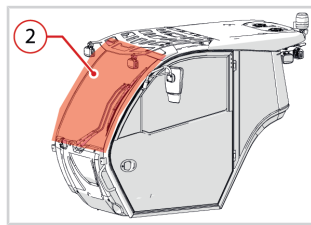

150423-2

The front glass of the cab (fig. 150423-1) can be used as an emergency exit in case the vehicle doors are locked.

Use the hammer "1" stored in the cab (Fig. 150423-2) to break the front glass "2" (Fig. 150423-2) in case of an emergency.

7.4 - Comfort



WARNING

The graphical representation (shapes and colours) of the switches is purely an indication, while the description explains their exact operation.

7.4.1 - Heated mirrors *



NOTE

Heated mirrors are optional attachments.

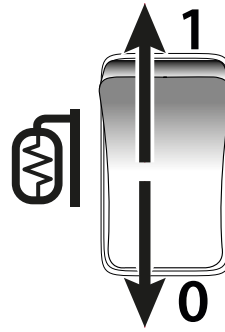

Figure: 160763-1

To start the heated mirrors function press the switch (fig. 160763-1).

The illuminated warning light on the switch indicates that the heated mirrors function is on.

7.4.2 - Electric window

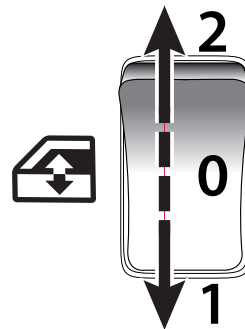

Figure: 171210-1

To move the door window, use the button on the door:

- 0 - Rest position
- 1 - Press to lower the window.
- 2 - Press to raise the window.



WARNING

Before closing the window check that there are no objects or human limbs that can be crushed by this.

7.4.3 - Canopy

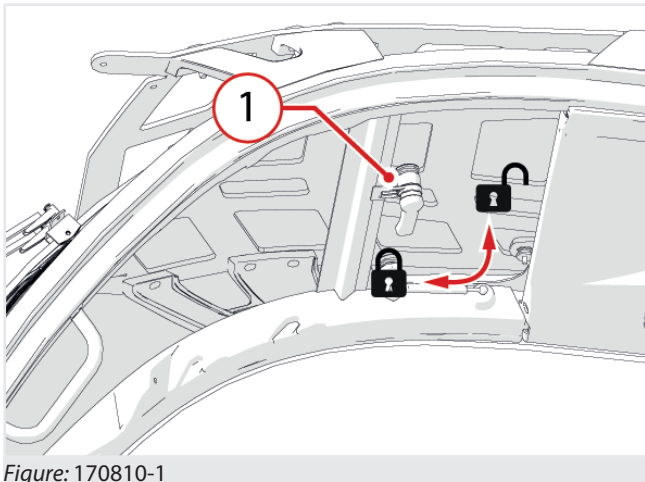

Figure: 170810-1

To open the roof, turn the handle "1" (Fig. 170810-1) to the open position and raise the roof.

To close proceed with the inverse operation until the handles are locked.

7.4.4 - Sunshade

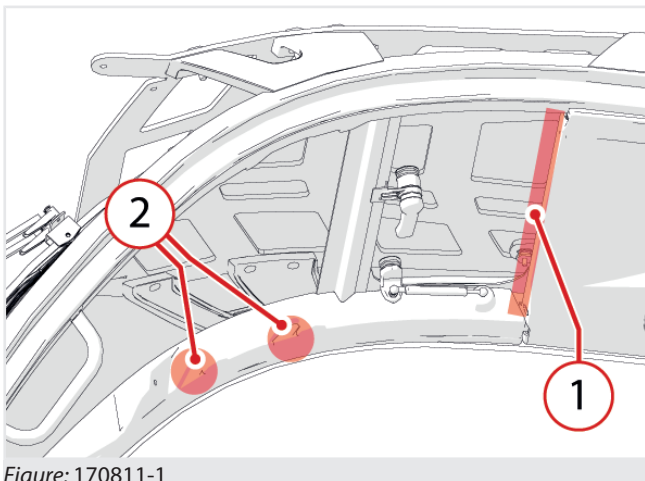

Figure: 170811-1

The Sunshade is located at the top of the cab.

To lower the Sunshade, take the handle located at the center of "1" (fig. 170811-1) and lower it down to lock it the hooks provided "2".

To close the sunshade, lower the handle "1" to release it from the hooks "2" and take back the sunshade in closure.

7.4.5 - Rear glass

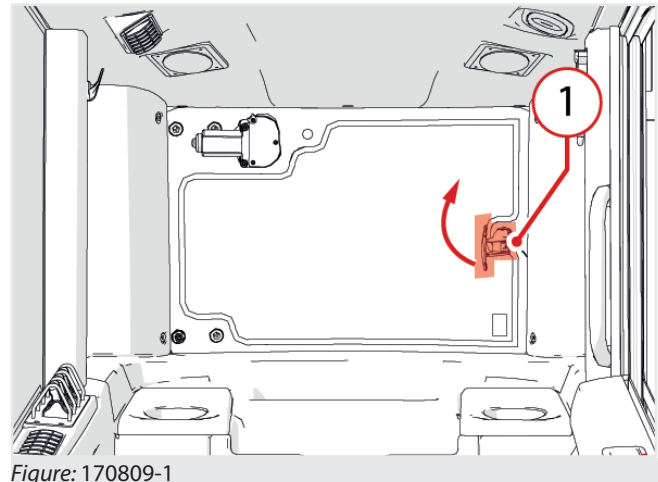

Figure: 170809-1

To open the rear glass, lift the handle "1" and push the glass outward.

The glass is maintained in the open position by the handle.

To close the rear glass, pull the handle back in the cab and lower until it until the whole unit is completely locked.



WARNING

Danger of crushing

In case the handle would no longer maintain the open position of the glass, replace it in the shortest possible time.



NOTE

The rear glass also serves as an emergency exit, see the "Safety Devices" chapter for more information.

7.4.6 - Storage compartment

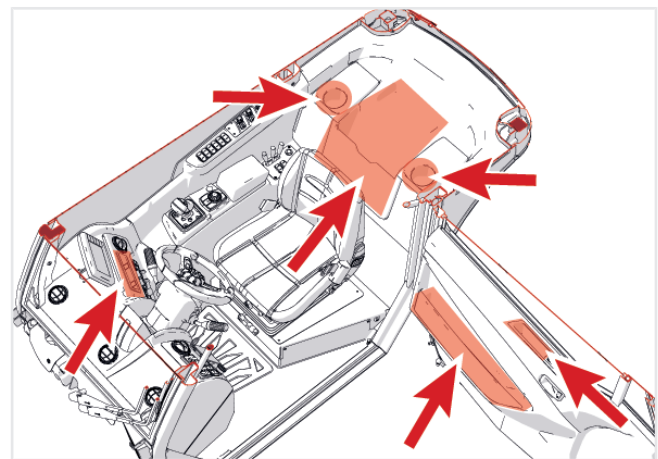

Figure: 171213-1

There are different storage compartments in the cab:

- Behind the seat
- On the sides of the seat
- In the car door at the bottom
- In the car door at the top
- On the right instrument panel (if no radio optional)

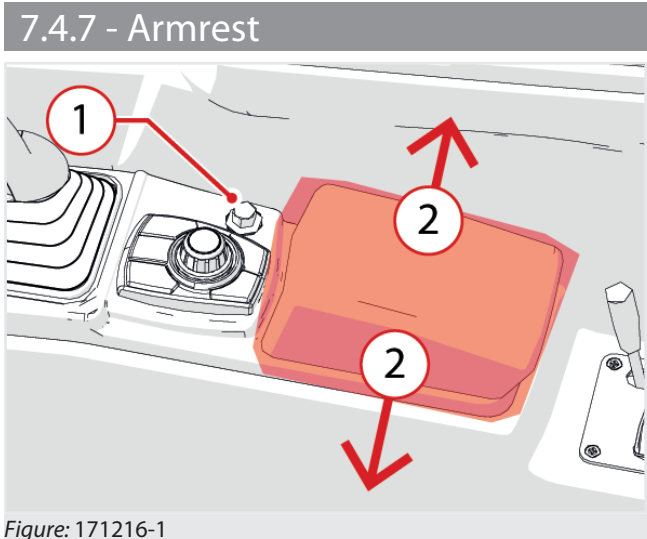

Figure: 171216-1

To adjust the height of the armrest (Fig. 171216-1) it is necessary to:

- Press and hold the button "1",
- Adjust the height of the armrest "2",
- Release button "1" to fasten the armrest in the desired position.

7.4.8 - USB ports*

NOTE

* The USB ports are optional devices.

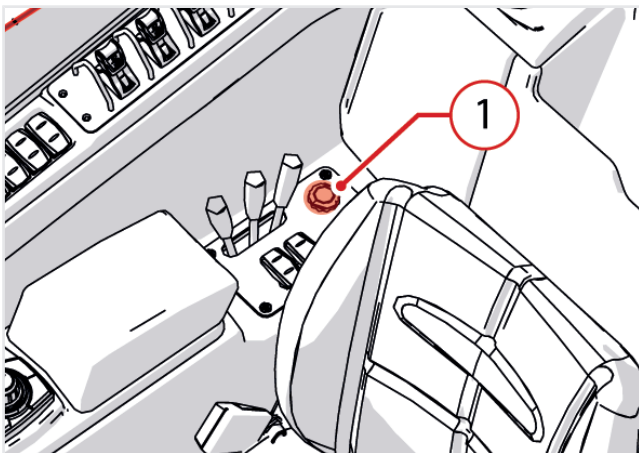

Figure: 171218-1

The USB sockets "1" (fig. 171218-1) allow to connect direct current devices (battery chargers, cell phones, etc.).

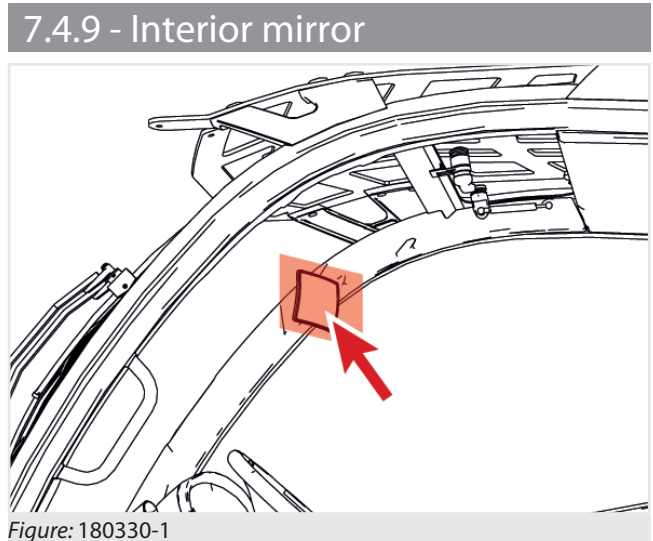

Figure: 180330-1

Adjust the internal rear-view mirror (fig. 180330-1) to have a good rear view during long trips.

7.4.10 - Mirror adjustment *

NOTE

* The electrically adjustable mirrors are an optional equipment.

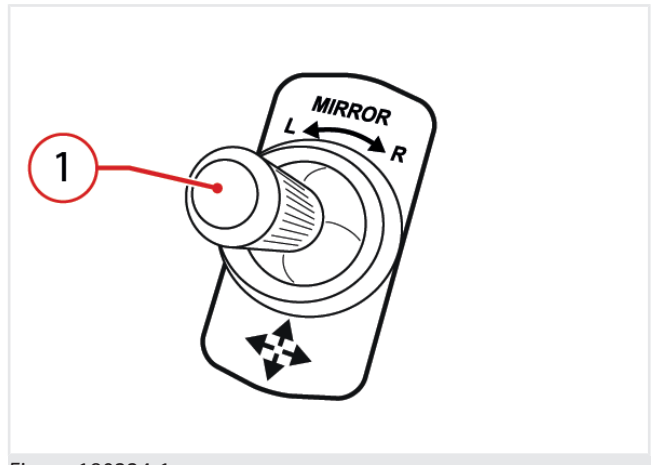

Figure: 180334-1

The angle of the wing mirrors can be adjusted using the joystick "1" (fig. 180334-1).

Turn the joystick handle "1" counterclockwise to select the left-hand wing mirror (LH) or clockwise to select the right-hand wing mirror (RH).

After selecting the desired wing mirror, move the joystick to change the positioning of the mirror.

7.5 - Lighting



WARNING

The graphical representation (shapes and colours) of the switches is purely an indication, while the description explains their exact operation.

When the side light are activated the instrument panel of the vehicle lights on.



NOTE

It is possible to turn on the side lights with the ignition key in "0" position, while it is necessary to bring the ignition key in position "I" to turn on the low beam lights.

7.5.1 - Emergency Lights

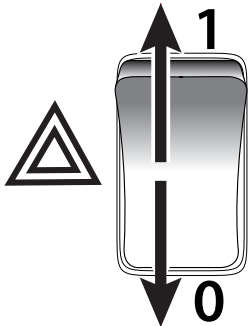

Figure: 171101-1

Press the emergency lights switch (fig. 171101-1) to turn on all four direction indicators.

- 0 - Emergency lights off
- 1 - Emergency lights flashing intermittently

7.5.2 - Sidelights and low beam lights

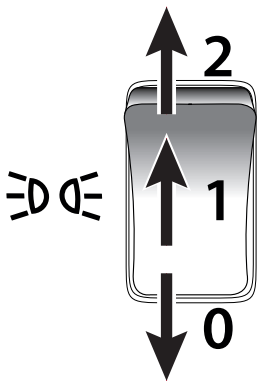

Figure: 171102-1

To turn on the front and rear side lights of the vehicle it is necessary to use the switch on the left instrument panel (fig. 171102-1).

The switch has 3 stable positions:

- 0- Lights off
- 1- Side lights on
- 2 - Low beam lights on

The LED on the switch lights up to indicate that the side lights are turned on.

7.5.3 - High beam lights

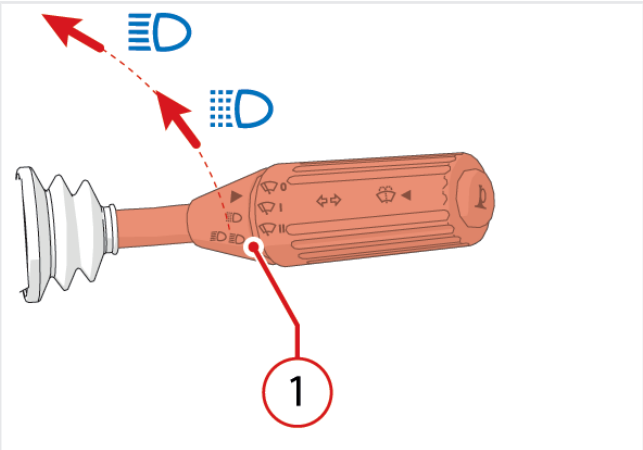

Figure: 150408-1

To turn on the high beam lights it is necessary to move the multifunction lever (fig. 150408-1).

- To make individual flashes with the high beam lights, pull the multifunction lever toward the steering wheel to the first click. It is possible to use this function with the lights off and the ignition key in position "0".
- To turn on the high beam lights, pull the multifunction lever toward the steering wheel to the second click. It is possible to turn on the high beam lights only with the ignition key in position "I" and low beam lights on. The high beam lights turned on is indicated by the warning light on the instrument panel.

In both cases, once obtained the desired click, the multifunction lever returns to its rest position.

7.5.4 - Direction indicators

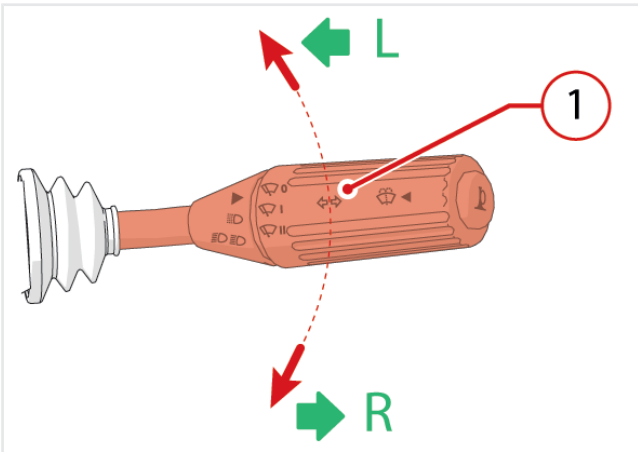

Figure: 150402-1

Move the lever (fig. 150402-1):

- Clockwise to indicate a right-hand bend (R).
- Counter-clockwise to signal a left-hand bend (L).

The indicators only work when the ignition switch is in the position of instrumentation on.

The indicator light on the central instrument panel will activate the direction indicators.



ATTENTION

Push the multifunction lever in stand-by position after making the turn, return to the neutral position is not automatic.

7.5.5 - Rotating light

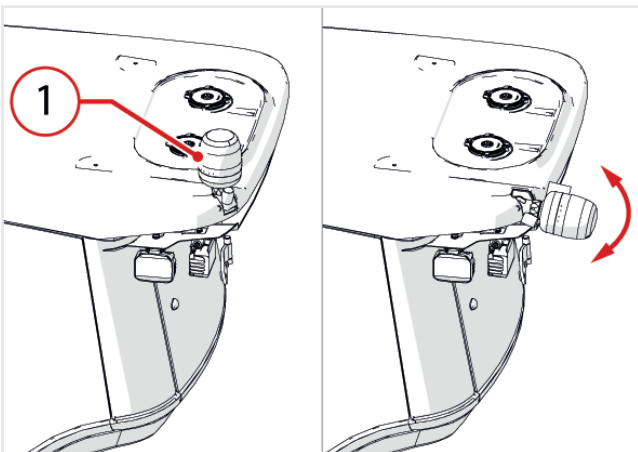

Figure: 171150-1

The rotating light "1" (fig 171150-1) is position onto the driver's cab.

It is possible to fold the rotating light backwards when not in use.

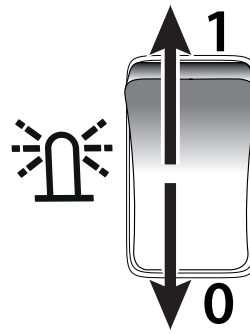

Figure: 171150-2

Press the switch (fig. 171150-2) to activate the rotating light:

- 0 - Rotating light off
- 1 - Rotating light on

The indicator on the switch lights up to indicate that the rotating light is turned on.



ATTENTION

Do not use the rotating light improperly.

Refer to the manager in charge of the work and to the regulations in force in the country of use of the vehicle to know the cases in which it is necessary and/or allowed to use the rotating light.



NOTE

It is possible to turn on the rotating light even if the ignition key is in the "0" position.

7.5.6 - Cab front light *



NOTE

* The cab front light is an optional accessory.

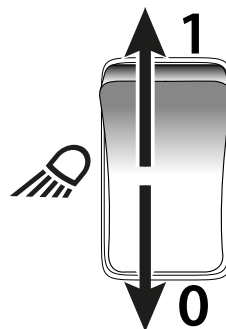

Figure: 150409-1

Press the switch (fig. 150409-1) to turn on the front work light.

The LED on the switch lights up to indicate that the light is on.



NOTE

To turn on the headlight it is necessary to bring the ignition key in position "I".

7.5.7 - Cab rear light *



NOTE

* The cab rear light is an optional accessory.

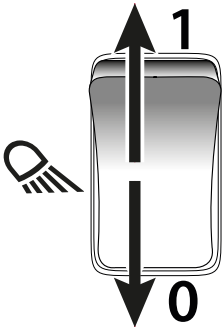

Figure: 150410-1

Press the switch (fig. 150410-1) to turn on the rear work light.

The indicator on the switch lights up to indicate that the light is on.



NOTE

To turn on the headlight it is necessary to bring the ignition key in position "I".

7.5.8 - Work light on the boom head*



NOTE

* The work light on the boom head is an optional accessory.

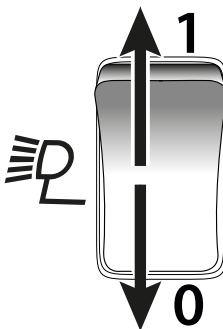

Figure: 150411-1

Press the switch (fig. 150411-1) to turn on the work light on the boom head.

The indicator on the switch lights up to indicate that the light is on.



NOTE

To turn on the headlight it is necessary to bring the ignition key in position "I".

7.5.9 - Perimeter lights *



NOTE

* Perimeter lights are an optional accessory.

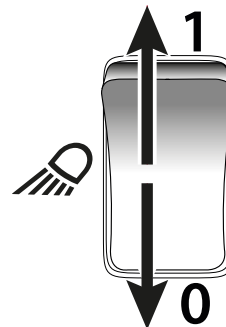

Figure: 150409-1

Press the switch (fig. 150409-1) to switch on the perimeter lights.

The LED on the switch lights up to indicate that the lights are on.



NOTE

To turn on the headlight it is necessary to bring the ignition key in position "I".

7.6 - Seat

The seat of the vehicle is equipped with specific safety belts designed to protect the operator during the movement or handling operations.



WARNING

Always fasten the seat belts when operating the vehicle.

7.6.1 - Deadman seat sensor

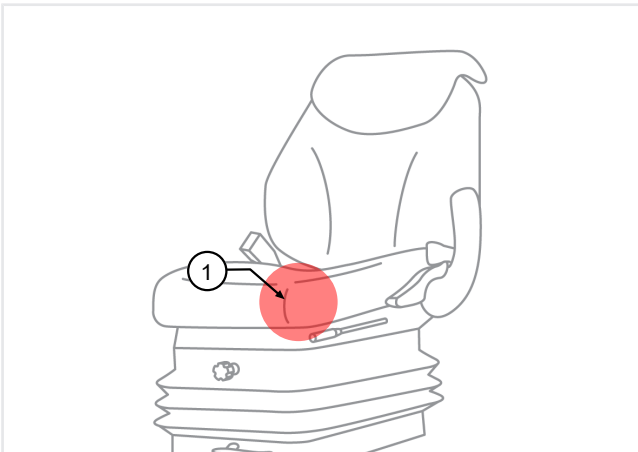

Figure: 150413-1

The vehicle is equipped with a safety system called "deadman" which consists of a magnetic sensor inside the seat cushion "1" (fig. 150413-1).

If the engine is running and the operator is not sitting properly in the driver's seat for a time longer than 3 seconds, the transmission is automatically disabled and the park brake is engaged.

To continue moving the vehicle, the operator must sit in the driver's seat and set the movement selection lever in position "N".



NOTE

The engine can be started only if the operator is seated properly in the driving seat and the gear lever is in neutral "N".

7.6.2 - Seat adjustment



ATTENTION

Correctly position the seat.

The seat is properly positioned when the operator is able to perform a full stroke to the brake pedal by holding the back against the backrest of the seat itself.

The seat can be adjusted to different positions:

Backrest inclination

To adjust the inclination of the backrest (fig. 150418-1), lift the lever on the left side and let the backrest adapt to the required position. Release the lever to block the backrest.

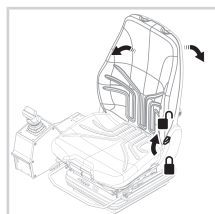

150418-1

Back cushion

Adjust the back cushion (fig. 150418-2) by turning the knob behind the backrest.

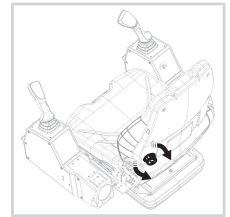

150418-2

Horizontal position of the seat unit

Adjust the entire seat unit longitudinally by moving the lever (fig. 150418-3) upwards and sliding the seat unit on the guides. Once established the desired position, release the lever. Perform small movements to make sure that the seat is fastened properly.



150418-3

Horizontal seat position

To adjust the seat longitudinally move the lever (fig. 150418-4) upwards and slide the seat unit on the guides. Once established the desired position, release the lever. Perform small movements to make sure that the seat is fastened properly.

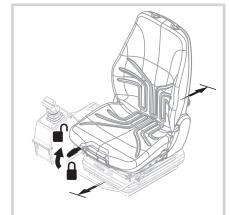

150418-4

Horizontal seat position

To adjust the seat longitudinally, press the right handle (fig. 150418-5) and slide the seat along the guides. Release the handle when the desired position is reached. Perform small movements to make sure that the seat is secured properly.



150418-5

Seat inclination

To adjust the seat inclination, press the left handle (fig. 150418-6) and adjust the seat to the desired position. Release the handle when the desired position is reached. Perform small movements to make sure that the seat is secured properly.

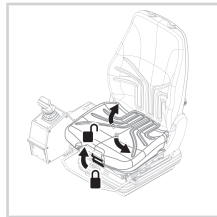

150418-6

Mechanical suspension degree

To adjust the degree of suspension (fig. 150418-7), turn the knob towards "+" to soften the suspension. Turn the knob towards the "-" to harden the suspension.

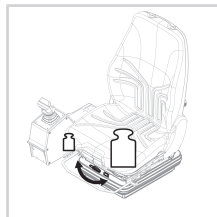

150418-7

Optimal adjustment is achieved when the weight indicated at the side of the lever corresponds to the weight of the operator.

Pneumatic suspension degree *



NOTE

The pneumatic suspension of the seat is an optional accessory.

To adjust the pneumatic spring rate, pull the knob (fig. 150418-8) to let out pressure and soften the suspension. Push the knob to add pressure and harden suspension.



150418-8

Pneumatic adjustment can only be performed with the engine running.

Adjusting the armrest

It is possible to lift or lower the armrest by hand (fig. 150418-9).

To adjust the height of the armrest when it is down, turn the knob located under it to the right to raise it, or to the left to lower the armrest.

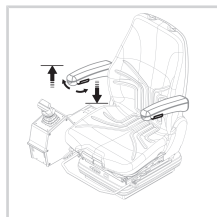

150418-9

7.6.3 - Seat belts



WARNING

Always fasten the seat belts when operating the vehicle.

The vehicle is equipped with a cab that can withstand the weight of the vehicle in the event of rollover (ROPS), it is therefore necessary that the operator remains tied to the seat by the seat belt not to be swept out and possibly crushed.

Before starting the vehicle, carefully examine the belts, buckles and fastening devices to the structure. If some component is damaged or worn, replace the seat belt or the component before operating the vehicle.

Remain seated with the seat belts fastened properly for all the time of operation of the vehicle to reduce the risk of injury in case of accident.

Following an accident of a certain importance, replace the seat belts, even if they do not appear damaged.

To fasten the seat belt is necessary to:

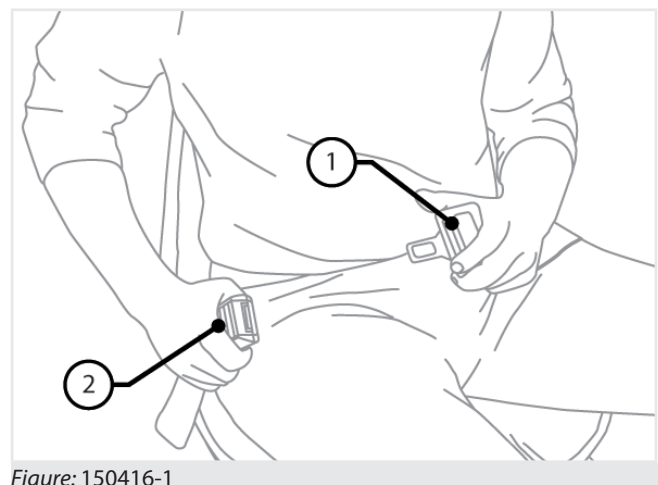

Figure: 150416-1

- Insert the tab "1" in the buckle "2".

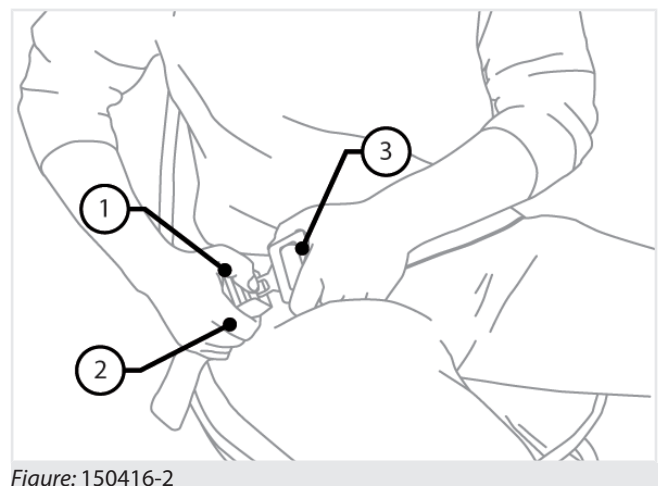

Figure: 150416-2

- Make sure of that the hooking occurred, and then adjust the belt around the body.
- The belt is considered properly connected when it is close to the body.

To remove the belt it is necessary to:

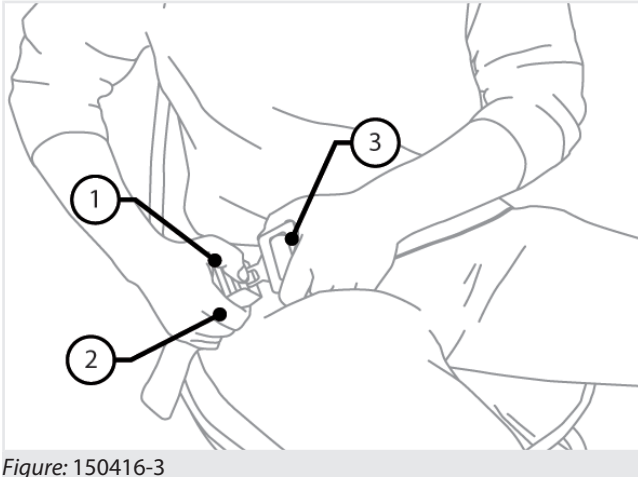

Figure: 150416-3

- Press the red button "1" on the buckle "2".
- Then remove the tab "3".



WARNING

Drive the vehicle only with safety belt properly worn, fastened and adjusted.

Operating without the seat belt fastened increases the risk of accidents.

Do not use damaged or worn seat belts. If worn, damaged or yielded belts are used, they can break or yield in case of collision resulting in serious injury to the operator.

7.7 - Windows



WARNING

The graphical representation (shapes and colours) of the switches is purely an indication, while the description explains their exact operation.

7.7.1 - Front window wiper

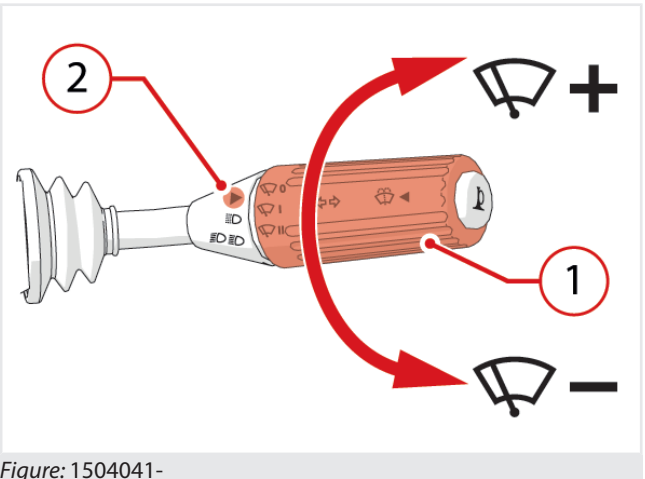

Figure: 150404-1

Turning the knob to "1" (fig. 150404-1) activates the front window wiper.

The arrow "2" indicates which window wiper speed is currently active.

- 0 - Off
- I - Slow
- II - Fast



WARNING

Worn blades cause viewing difficulties and scratches to the glass.

Replace the blades if they are damaged or worn.

7.7.2 - Window washer

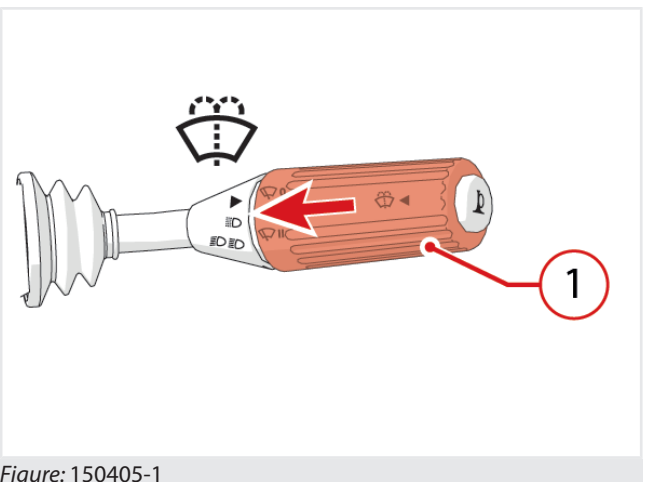

Figure: 150405-1

Press the middle button on the lever "1" (fig. 150405-1) to turn on the front window washer.

7.7.3 - Upper and rear window wiper and washer

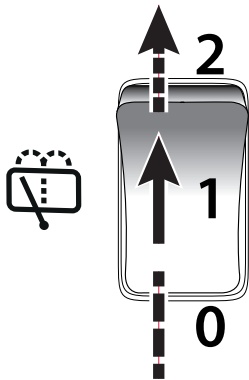

Figure: 150406-1

The switch of the rear and upper window wiper and washer (fig. 150406-1) has 3 positions, 2 stable and 1 unstable:

- 0 - Window wiper off
- 1 - Window wiper on
- (2) - Rear window wiper in operation, until pressed

7.7.4 - Window wiper-washer on boom side *



NOTE

* The window wiper-washer on boom side is an optional attachment.

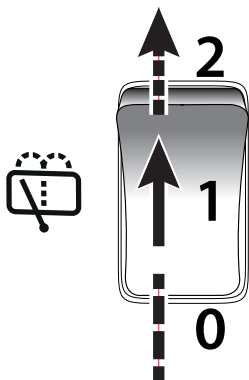

Figure: 150406-1

The window wiper-washer on boom side switch (fig. 150406-1) has 3 positions, 2 of which are stable and 1 unstable:

- 0 - Window washer on boom side off
- 1 - Window washer on boom side on
- (2) - Window washer on boom side in operation, until pressed

7.7.5 - Wiper fluid tank

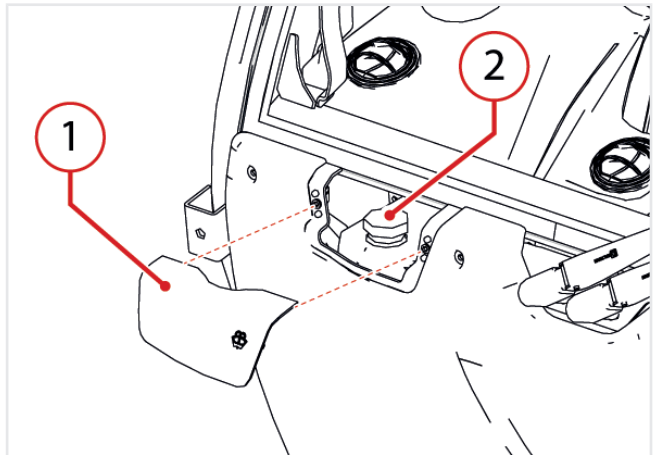

Figure: 180331-1

The washer fluid tank is located on the front external side of the cab (fig. 180331-1).

To add liquid to the tank:

- Stop the vehicle and engage the parking brake,
- Get off the vehicle and remove the magnetic cover "1",
- Remove the filling cap "2",
- Add washing fluid to fill the tank.
- Put back the cap "2".
- Reassemble the magnetic cover "1".



ATTENTION

During the winter, mix antifreeze fluid to the water.

7.8 - Instrument panel

7.8.1 - Components

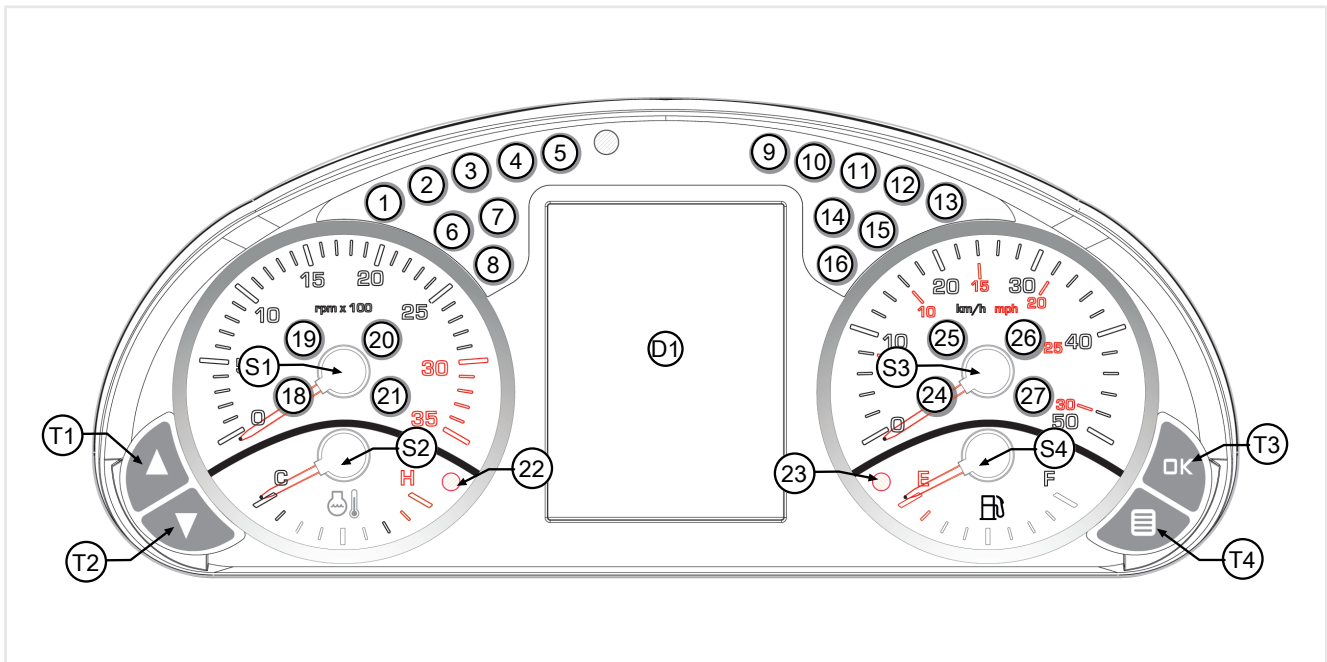









Figure: 150425-1 - Instrument panel components

Position	Indicator light			Description
T1	-	-	-	UP button
T2	-	-	-	DOWN button
T3	-	-	-	OK button
T4	-	-	-	MENU key
D1	-	-	-	Display
S1	-	-	-	Tachometer indicator
S2	-	-	-	Engine water temperature indicator
S3	-	-	-	Speed indicator
S4	-	-	-	Fuel level indicator
1		Red	Fixed	Generator, battery failure
2		Red	Fixed	Presence of water in the fuel filter
3		Red	Fixed	Engine air filter clogging
4		Yellow	Fixed	Engine pre-heating
5		Red	Fixed	Engine oil low pressure
6		Yellow	Fixed	Engine warnings present
7		Red	Fixed	Engine errors present, engine in limited power mode

Position	Indicator light		Description	
8		Green	Fixed	Forward movement engaged
9		Yellow	Fixed	DPF regeneration in progress (during regeneration the engine idle speed increases)
10		Yellow	Fixed	Automatic DPF regeneration disabling
11		Yellow	Fixed	Medium level of soot
		Flashing	DPF regeneration requested: - Slow flashing: high level of soot; - Fast flashing: critical level of soot	
12		Yellow	Fixed	Inducement warning for low level of AdBlue
		Flashing	- Slow flashing: moderate inducement for low level of AdBlue; - Fast flashing: critical inducement for low level of AdBlue	
13		Yellow	Fixed	Low inducement for AdBlue technical error
		Flashing	- Slow flashing: moderate inducement for AdBlue technical error; - Fast flashing: critical inducement for AdBlue technical error	
14		Yellow	Fixed	Inducement warning for AdBlue low quality
		Flashing	- Slow flashing: moderate inducement for AdBlue low quality; - Fast flashing: critical inducement for AdBlue low quality	
15		Red	Fixed	Inducement active at Level 1
		Flashing	- Slow flashing: inducement active at Level 3; - Fast flashing: inducement active at Level 5	
16		Green	Fixed	Backward movement engaged
18		Blue	Fixed	High beam
19		Green	Fixed	Direction indicators
20		Red	Fixed	Parking brake engaged
21		Green	Fixed	Side lights
22	-	Red	-	Engine water high temperature
23	-	Yellow	-	Fuel reserve
24		Red	Fixed	Hydraulic oil high temperature
25		Red	Fixed	Hydrostatic oil filter clogging
26		Red	Fixed	Parking brake insufficient pressure
27		Red	Flashing	Brakes oil low level
		Fixed	Braking system failure	

7.8.2 - Initial loading

When the panel is switched on, the system will perform a check of all the indicator lights and all the indicators. During the check, on the screen there will be a loading bar "1" (fig. 180343-1).



Figure: 180343-1

After completing the initial check the display shows the main Home screen.

7.8.3 - Display

The Home screen (fig. 180339-1) is the standard display, containing the information required by the operator to use the vehicle.

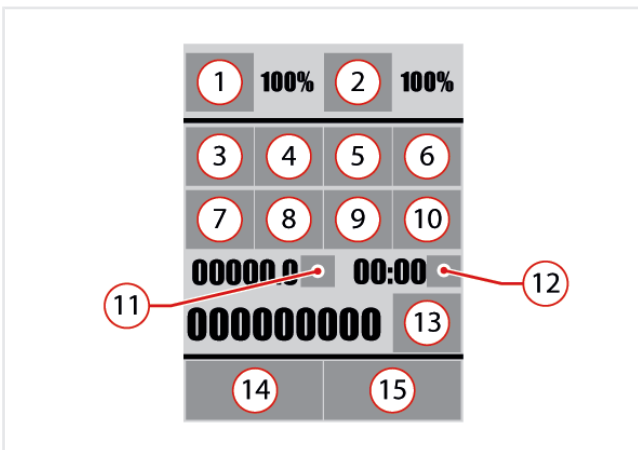

Figure: 180339-1

Position	Description
1	Equipment capacity * [▶ 83]
2	Longitudinal momentum indicator
3	General alarm icon and/or boom absolute angle [▶ 84]
4	Transmission Icon [▶ 85]
5	Anti-tipping device ByPass icon [▶ 86] Seat Switch icon [▶ 86] Wheels alignment check icon * [▶ 86]

Position	Description
6	Outriggers icon * [▶ 86]
7	Lifted boom icon Active regeneration icon ECO icon
8	Service [▶ 84]
9	Not connected man basket icon * [▶ 86] Boom Chains Error icon * [▶ 87] Levelness Icon * [▶ 87]
10	Hydraulic sockets on boom head icon * [▶ 87]
11	Hour meter [▶ 85]
12	Clock [▶ 85]
13	Active errors [▶ 89]
14	AdBlue quantity
15	DPF level

* Icons present depending on the optional equipment.

7.8.4 - Equipment capacity *



NOTE

* **The Equipment capacity icon is part of an optional attachment.**

Refer to the Automatic Equipment Recognition chapter.

The Equipment capacity icon indicates the working mode in which the vehicle is set and the capacity percentage of the equipment installed.

Icon	Description of the mode
	Forks The Forks mode is enabled when using equipment without an equipment recognition system. No capacity percentage is shown.
	Lifting equipment with limiter The Lifting equipment mode is enabled when using equipment with flow limiter. The equipment capacity percentage is displayed.
	Man Baskets The Man Basket mode is enabled The basket capacity percentage is displayed.

Icon	Description of the mode
	<p>Equipment recognition error</p> <p>In the event of an error in the automatic equipment recognition system, the forks mode is enabled and no capacity rate is shown.</p> <p>Check the correct installation of the equipment and contact the reference service center to resolve the error.</p>

7.8.5 - General alarm icon and/or boom absolute angle

The general alarm icon (fig. 150430-1) lights on together with other signals, to underline danger to the safety of the vehicle or the operator.

If the vehicle is in motion, the General alarm icon is accompanied by a general alarm acoustic signal.

In the absence of a general alarm signal, only the boom absolute angle is displayed.

In the presence of an alarm, the icon alternates with the angle value (150430-1A).

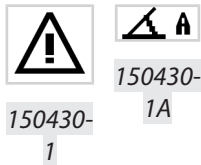

General alarm icon	Acoustic signal	Condition
On	Intermittent	Generator, battery failure
On	Intermittent	Engine oil low pressure
On	Intermittent	Engine air filter clogging
On	Intermittent	Hydrostatic oil filter clogging
Intermittent	Continuous	Reached engine overspeed limit
Intermittent	Continuous	Reached maximum speed limit

7.8.6 - Service

The **Service indicator light (every 500h)** indicates the intervals the maintenance has to be carried out.

20 hours before the deadline, the icon stays on for 30 seconds after switching on the instrument panel.

The icon stays on permanently until maintenance is carried out by specialized personnel.

After completing the maintenance, the specialized technician will perform the reset.

The fault state of **supply fuse** gets activated if any of the following inputs is missing when the tool is on:

- +15
- +15 fuse
- +30 fuse

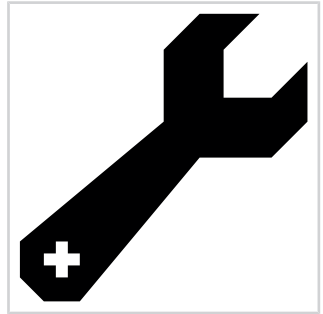

Service Indicator Light

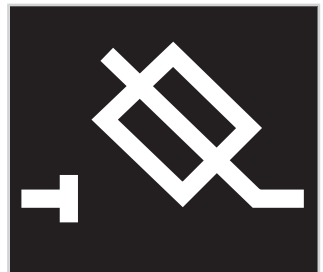

Fuse +15 and +30 state

The **Equipment service** icon represents the state of the programmed maintenance.

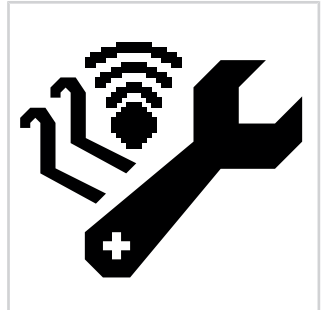

Equipment service

Blocked rear axle.



Blocked axle

Display of remaining hours before maintenance

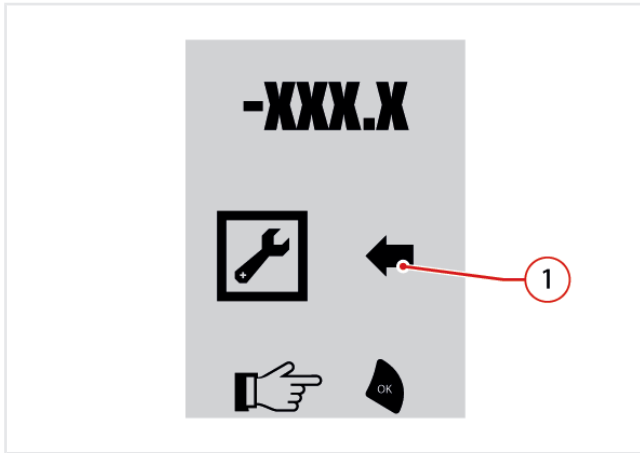

Figure: 180341-2

To find out the hours remaining to next maintenance, it is necessary to access the Service page (fig. 150434-2):

- Press the **MENU** button,
- Select the Service icon,
- Press the **OK** button.

To return to the Home screen, simply press the **MENU** button or select the **BACK** icon "1" and press the **OK** button.



NOTE

Contact the Deci technical service to perform maintenance and reset the Service hour counting.

7.8.7 - Clock

On the home screen there is the indication of the time next to the related icon (fig. 180340-1).



180340-1

Setting the clock

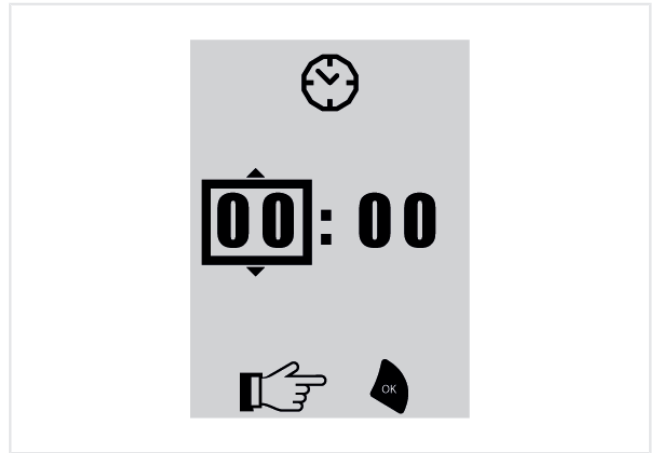

Figure: 180340-2

To adjust the time it is necessary to (fig. 180340-2):

- Press the **MENU** button,
- Select the clock setting icon,
- Press the **OK** button,
- Use the **UP** and **DOWN** to set the hour digits,
- Press the **OK** button,
- Use the **UP** and **DOWN** to set the minutes digits,
- Press the **OK** button to set the new time.

Press the **MENU** button at any time to cancel the process and return to the Home screen.

7.8.8 - Hour meter

On the home screen there is the indication of the hour meter next to the related icon (fig. 150440-1).



150440-1

The separation of the decimal point flashes when the hour meter is active.

7.8.9 - Transmission Icon

The Transmission icon indicates the mechanical gear currently in use:

Icon	Description
	Hare Fast gear engaged, it allows the vehicle maximum speed during the travels.
	Tortoise Slow gear engaged, the vehicle has more torque to the detriment of the maximum speed.

7.8.10 - Outriggers icon *



NOTE

* **The Outriggers icon is part of an optional attachment optional only on some vehicle models.**

Refer to the chapter Outriggers * [▶ 111] (if present).

The Outriggers icon indicates the following statuses:

Icon	Description
	Outriggers lifted: The front wheels are resting on the ground.
	Outriggers down: The front wheels are raised from the ground.
	"Safe travelling" position: <ul style="list-style-type: none"> • The outriggers are completely raised; • The telescopic boom is lowered and closed.

7.8.11 - Low Idle UP icon



A



B

"A" icon: the "LOW IDLE UP" configuration is active on the vehicle, as the Safe State condition is verified.

In this state, the engine rpm are increased in order to reduce the accumulation of unburned hydrocarbons.

"B" icon: engine control unit requires the "LOW IDLE UP" configuration; the machine should be set to Safe State mode.

The Safe State setup involves:

- Vehicle stopped;
- No boom movements;
- Parking brake on.

The icons turn off when the operator manually raises the engine rpm above the levels required for HC Removal Strategy.

7.8.12 - Anti-tipping device ByPass icon

The Anti-tipping Device ByPass icon is displayed when the ByPass key is used.



180351-2

7.8.13 - Seat Switch icon

The icon (fig. 150443-1) lights on when the operator is not properly seated in the driver's seat.



150443-1

7.8.14 - Wheels alignment check icon *



NOTE

* **The Wheels alignment check icon is part of the optional attachments.**

Refer to the chapter Wheels alignment check *.

The Wheels alignment check icon indicates when the wheels are aligned and parallel to the vehicle chassis.

Icon	Description
	Front wheels aligned
	Rear wheels aligned
	Front and rear wheels aligned

7.8.15 - Not connected man basket icon *



NOTE

* Not connected man basket icon is part of an optional attachment.

The not connected man basket icon (fig.180403-1) indicates the error status in which the automatic equipment recognition system detects the installation of a man basket, but the electrical connection between the basket and the vehicle has not been made.



180403-1

7.8.16 - Boom Chains Error icon *



NOTE

The boom chains error icon is present only on vehicles with telescopic boom with chains and prearrangement for man basket.

The icon (fig. 150445-1) indicates loosening or breaking of the telescopic boom chains.



150445-1

When the icon turns on, stop the working operations and service the chains.



ATTENTION

Contact an authorized service center

Consult the Control Log and the Maintenance Log to know the timelines and operations to be carried out.



DANGER

If at least one chain is loose or broken, activate the emergency procedure for the basket recovery.

In case of breakage of one or both chains, in addition to the indication on the display:

- An acoustic signal is activated both in the cab and outside, which can be stopped by pressing the "OK" button on the instrument panel.
- If the man basket is used, the green light on the control panel flashes.

7.8.17 - Levelness Icon *



NOTE

The Levelness icon is present on vehicles with pre-arrangement for man basket.

The levelness icon indicates when the vehicle is in a working condition within the maximum tilting limits set by the manufacturer.

Icon	Description
A	The icon indicates that the vehicle is within the working limits and can operate normally.

Icon	Description
B	The icon indicates that the vehicle is out of the allowed tilting limits and must be leveled in order to proceed with the work.

When working with the man basket, the pilot light "B" turns on together with an acoustic signal that can be silenced by pressing the "OK" button on the instrument panel.

It is possible to see the exact levelness values accessing the Check page [▶ 89].

7.8.18 - Hydraulic sockets on boom head icon *



NOTE

* The Hydraulic sockets on boom head icon is part of the optional attachments.

The Hydraulic sockets on boom head Icon indicates the active hydraulic socket on the boom head.

Icon	Description
F0	Standard active hydraulic socket
F1	First additional active hydraulic socket
F2	Second additional active hydraulic socket

7.8.19 - Pop-up for accumulation of unburned hydrocarbons (HCs) *



NOTE

The unburned hydrocarbons accumulation pop-up is present in Stage V engines only

This caution specifies the accumulation of unburned hydrocarbons (HCs) inside the ATS system.

Activation will depend on the state of HC accumulation at level 4 or higher.

The pop-up is automatically displayed every 60 seconds for 5 seconds when the HC accumulation level is greater than/equal to 4.



7.8.20 - FPT Stage V AdBlue quantity

The Home screen contains the AdBlue Quantity indicator (fig.180404-1).



The AdBlue Quantity indicator is expressed as a percentage, where:

- 0% indicates the empty tank
- 100% indicates the full tank.

NOTE

Refer to the chapter "AdBlue®".

When the AdBlue level is below 10%, the "AD BLUE" message flashes slowly, while when it is below 5%, it flashes fast.

7.8.21 - Menu

From the Home screen, it is possible to access the menu (fig. 180347-1) pressing the **MENU** key.

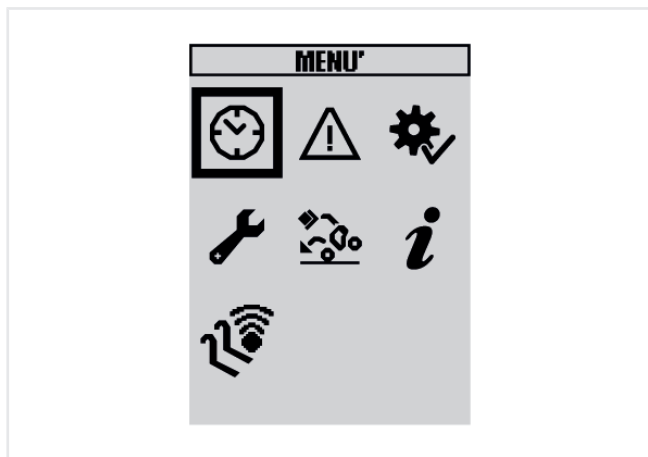

Figure: 180347-1

Use the **UP** and **DOWN** buttons to scroll through the menu items and press the **OK** button to make a selection and go to the related page.

The menu items are:

	Clock [▶ 85]
--	--------------

	Active errors [▶ 89]
	Check page [▶ 89]
	Service [▶ 84]
	Anti-tipping calibration (Reserved to qualified personnel)
	Info page [▶ 88]
	Equipment Info page * [▶ 89] (only if the Equipment recognition attachment is present)

7.8.22 - Info page

The Info page provides information about the software version installed on the vehicle.

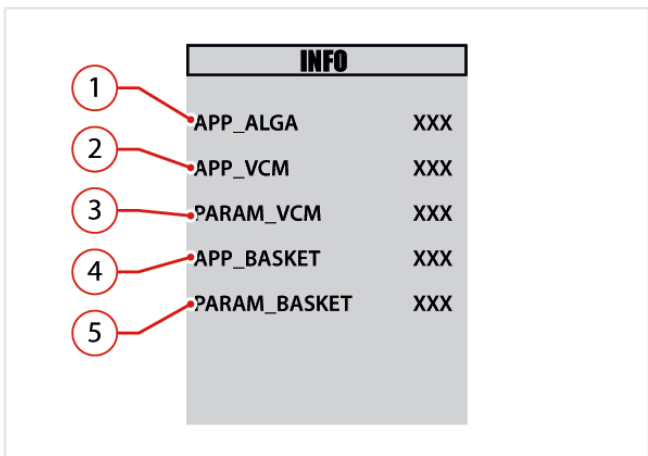

Figure: 180350-1

1	Software version
2	VCM software version
3	VCM parameter version
4	Man basket control unit software version
5	Basket control unit parameter version

To access the Check screen it is necessary to:

- Press the **MENU** button,
- Select the Info icon,
- Press the **OK** button.

To return to the Home screen, simply press the **MENU** button or select the **BACK** icon and press the **OK** button.

7.8.23 - Active errors

The presence of errors will be reported by the general warning icon, by the acoustic signal lasting 1.5 sec. and by the displaying of the error code on the Home screen instead of the time.



150432-1

In the presence of more than one error, the error codes will be displayed cyclically every 2 sec. on the Home screen. At the end of the cycle showing all the active errors, an icon will be displayed that indicates the user to access the Active Errors page to view all active errors in that time.

In case of an error from the SAR, the acoustic signal will be continuous and the error code will remain fixed on the Home screen. Press the **OK** button to stop the sound of the acoustic signal and resume the active errors displaying cycle.

Active errors displaying

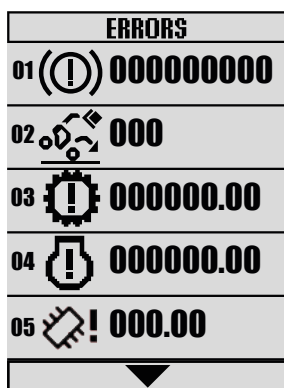

Figure: Active errors

To enter the Active errors page it is necessary to:

- Press the **MENU** button,
- Select the Active errors icon,
- Press the **OK** button,

Use the **UP** and **DOWN** buttons to scroll though the pages if there are several errors. The arrows at the bottom of page "1" indicate the presence and directions in which the additional pages flow.

Press the **MENU** button at any time to return to the Home screen.

Each error code is associated with an icon that identifies the nature of the error:

Icon	Example	Description
(!)	000000000	Parking brakes errors or brakes failure
(SAR icon)	000	SAR errors ALGA errors
(Gear icon)	000000.00	Transmission errors
(Lightning bolt icon)	000000.00	Engine errors
(Chip icon)	00.00	Vehicle control unit (VCM) errors
(Lightning bolt icon)	000000.00	Post treatment errors
(Screwdriver icon)	0000.00	Fuse state
(Basket icon)	000.00	Basket (BCM) errors

7.8.24 - Check page

The Check page is used to view the vehicle input and output parameters. This page can be consulted to provide additional information on the behavior of the vehicle in case of faults or malfunctions.

To access the Check screen it is necessary to:

- Press the **MENU** button,
- Select the Check icon,
- Press the **OK** button.

Press the **OK** button to scroll through the pages.

To return to the Home screen, simply press the **MENU** button.

7.8.25 - Equipment Info page *



NOTE

* The equipment info page is an optional equipment.

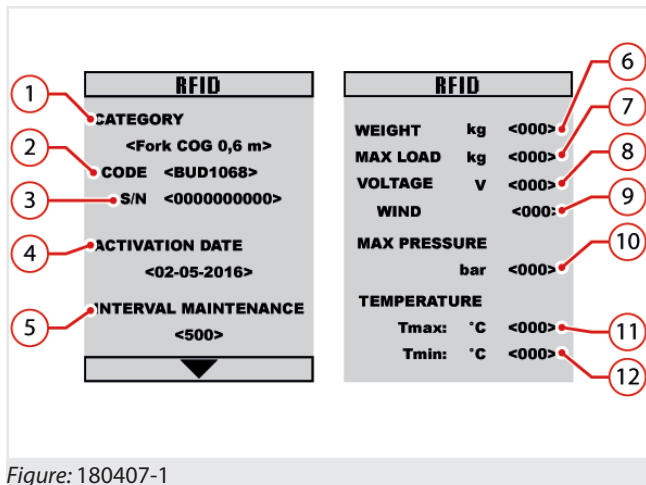

Figure: 180407-1

1	Category	Category name.
2	Code	Equipment code.
3	Serial number	Serial number of the equipment
4	Activation date	Date of first use of the equipment.
5	Maintenance interval	Time interval for ordinary maintenance on the equipment.
6	Weight	Equipment weight in kg.
7	Maximum capacity	Maximum equipment capacity in kg (if present).
8	Electric voltage	Electric voltage for using the V equipment (if present).
9	Wind force	Maximum wind force for using the equipment in m/s (if present).
10	Maximum pressure	Maximum hydraulic working pressure of the equipment in bar (if present).
11	Maximum temperature	Maximum operating temperature of the equipment in °C.
12	Minimum temperature	Minimum operating temperature of the equipment in °C.

To access the Equipment Info Page screen:

- Press the **MENU** button,
- Select the Equipment Info icon,

- Press the **OK** button.

Press the **UP** and **DOWN** keys to scroll through the pages.

To return to the Home screen, simply press the **MENU** button.

7.9 - Anti-tipping device

The vehicle is equipped with an anti-tipping device that has the purpose to help the operator to use the vehicle safely with different acoustic and visual warning signals according to the vehicle overturning danger.

The anti-tipping device is always active.



WARNING

This device can not replace the good experience of the operator in using the vehicle safety; the operator is the only one responsible for the safe operation of the vehicle and compliance with all safety standards prescribed.

The operator must be able to determine if the data provided by the instrument are correct and real, using them for a safe use of the vehicle. When checking the loaded weight, make sure that this is lifted from the ground. When turned on, the device starts a self-diagnostic program to check the proper operation of itself and of the transducers. In case of failure, the device sets itself in a safety state and stops the operations.

Therefore the operator, before starting to work, must make sure that the instrument operates correctly:

- Check for messages and alarms on the panel.
- Check that the device operates correctly.

The operator must, in case of any type of anomaly, immediately contact an authorised workshop or a DIECI authorised service centre.

The device is always in operation.

The device is not intended for warning about the risk of tipping in case of:

- Transverse overturning
- A sudden overload,
- Transport/movement with the load in an elevated position,
- Movement on rough terrain, with obstacles or holes;
- Transport/movement on a slope or in the vicinity of a slope;

- High speed of movement on straight lines and on turns.



ATTENTION

When the limit load is reached, the device automatically locks all the aggravating movements for the stability of the vehicle. Only the movements that allow to return the vehicle in safety conditions will remain active.

7.9.1 - ByPass key



DANGER



Danger of tipping

The ByPass Key must be used only if all of the following conditions occur:

- In case the maximum tipping limit and danger of vehicle overturning has been reached,
- By skilled and properly trained personnel,
- For short periods of time,
- In case it is not possible to restore the safety conditions.



Figure: 180351-1

The ByPass Key (fig. 150436-1) is with hold down action, therefore, must be maintained rotated during the operation for setting the vehicle in safe conditions.



180351-2

When using the ByPass key, the display will show the related icon "3" (fig. 180351-2).

The ByPass Key function turns off automatically after 30 seconds, even if the key continues to be rotated.

After reaching the safety zone, the alarm stops and the ByPass key can be released.



DANGER



DO NOT MAKE THE DESCENT OR THE EXTENSION OF BOOM MOVEMENTS AS THEY ARE MOVEMENTS AGGRAVATING THE STABILITY OF THE VEHICLE.

When using the bypass key, only make the return or the slope of the telescopic boom, bringing this in safety situation.



WARNING



When using the bypass key the anti-tipping systems are disabled.

It is mandatory to consult the load charts of the vehicle and the equipment installed before performing any manoeuvre.

Use the inclinometer and the letters on the boom to know the exact position of the load.

In these conditions do not perform aggravating movements for the stability of the vehicle, there is a danger of loss of stability and tipping.



NOTE

The bypass function is performed by a key to give the possibility to the Safety Officer to extract the key to prevent deactivating the anti-tipping system during normal working conditions.

7.9.2 - Longitudinal momentum indicator

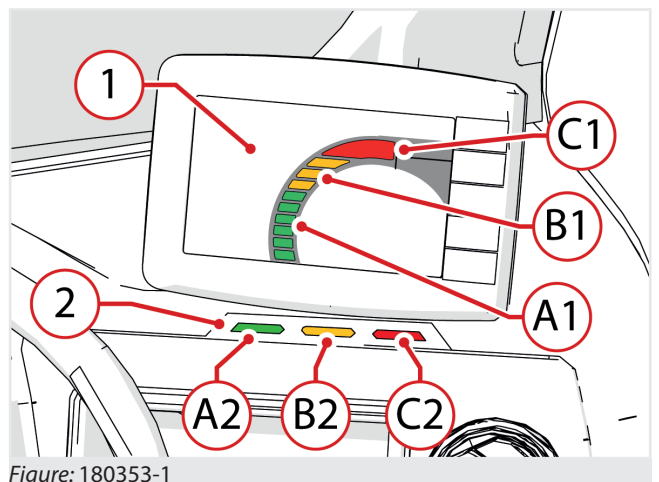





Figure: 180353-1

The longitudinal momentum indicator consists of (fig. 180353-1):

- an icon on the display,
- Tipping risk percentage bar on the display "1",
- LED lights on the right instrument panel "2".

Status:	Normal work
Icon:	 (Steady on)
Percentage bar:	A1 (Green)
Led:	A2 (Green)
Status:	Pre-alarm
Icon:	 (Flashing)
Percentage bar:	B1 (Orange)
Led:	B2 (Orange)
Status:	Alarm
Icon:	 (Steady on)
Percentage bar:	C1 (Red)
Led:	C2 (Red)

7.9.3 - Operation check with anti-tipping device load



ATTENTION

It is mandatory to check the proper operation of the anti-tipping device at the beginning of each work restart.

For a proper check of the device carry out the following operations (fig. 150438-1):

- Place the vehicle on a flat, level surface, align the wheels and engage the parking brake.
- Make sure that the equipment is properly installed on the vehicle and that it is suitable for its capacity.
- Make sure that the anti-tipping device is set for the equipment currently used.

- Perform the test with warm vehicle engine.
- Refer to the load charts of the equipment installed and with closed boom pick up a load approximately weighing 50% of maximum capacity.
- Raise the load at about 50 cm from the ground.
- With the engine idling, extend the boom slowly. During this operation, check the display of the anti-tipping device. When the red zone is reached, the continuous audible signal will operate and the extension movement will stop simultaneously.
- At this point, check that aggravating movements for the equipment assembled are not permitted.
- Check that the stopping occurs at the point indicated in the load chart shown in notebook inside the cab.
- In the event that everything is working properly, it is possible to begin the work.

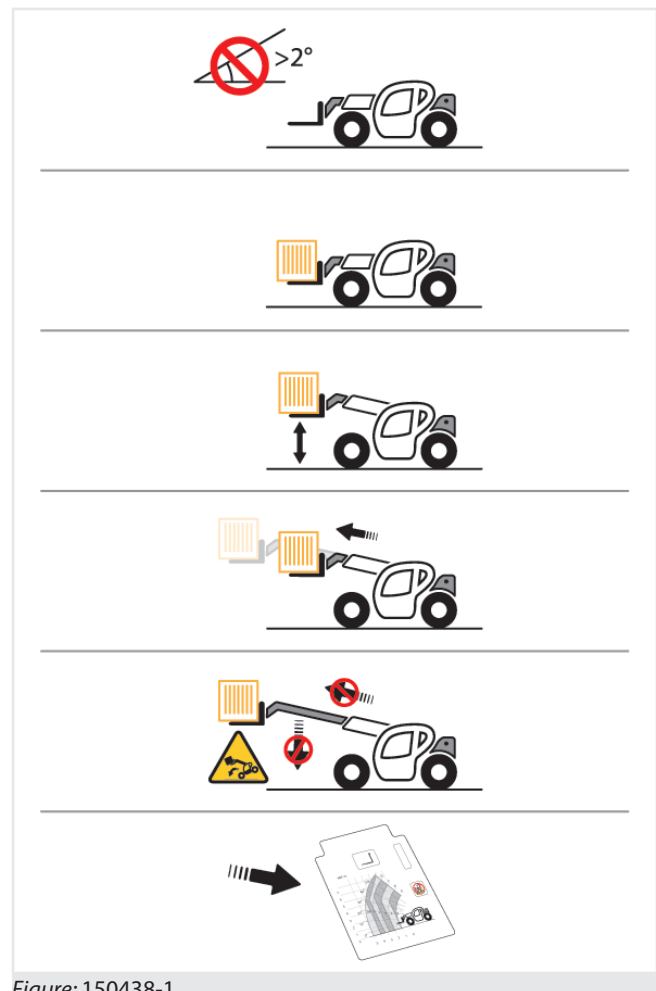

Figure: 150438-1



DANGER



If there are any faults of the safety devices, stop the work until it has been repaired.

Contact the *Dieci* service center.

7.10 - Guide and Transmission

7.10.1 - FNR commands on joystick

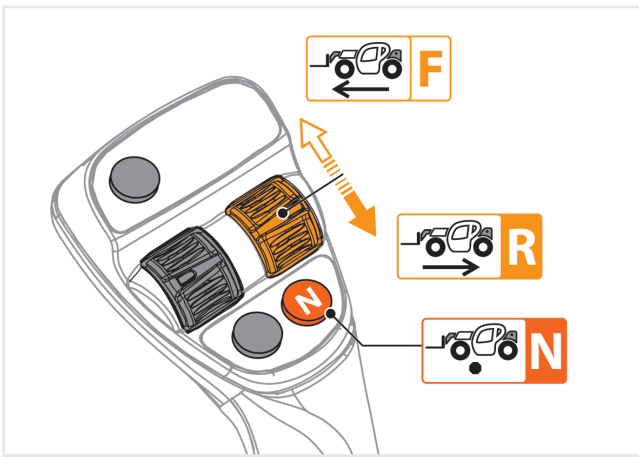

Figure: 180550-1

On the Joystick there is the F/R roller that is used to select the direction of travel in a faster and more ergonomic way:

- Move the F/R roller forward ("F" direction) to travel forward.
- Move the F/R roller backward ("R" direction) to travel in reverse. When driving in reverse, an alarm sounds intermittently.

The N button makes it possible to set the transmission in neutral and the vehicle is partially braked.



WARNING

The F/R roller and the N button do not need the deadman enable to operate.

To enable the F/R roller (forward / backward) is necessary to maintain the movement selection lever in N.

The controls given by the movement selector lever (if installed) will have priority over those of the joystick.

After selecting a direction of movement, the corresponding indicator lights on the instrument panel turn on:



"F" forward movement



"R" reverse movement

-

While holding the lever in the intermediate "N" position the transmission is in neutral and both indicator lights will turn off.

The movements of the F/R roller are not active when:

- The handbrake is engaged
- The operator is not properly seated in the driver's seat



NOTE

If the operator is not sitting properly in the driver's seat, the transmission is automatically switched off.

To continue moving the vehicle, the operator must sit in the driver's seat and press the button "N".



WARNING

After selecting the vehicle movement direction, it starts suddenly to move in the selected direction.

Before selecting the movement direction make sure that nobody is standing near the vehicle.



WARNING

It is dangerous to operate the F/R roller with the engine at high rpm or at a speed higher than 2 km/h (1.2 mph).

Before reversing the direction of movement, minimize the engine speed and select the new direction. Danger of vehicle overturning severe breakage of mechanical parts.

7.10.2 - Movement selection lever FNR*



NOTE

*** The FNR movement selection lever is an optional equipment.**

The FNR roller will be present on the vehicle and it can be used for the same function of the movement selection lever.

The movement selection lever has priority over the FNR roller on the joystick.

In order to select a direction of movement, it is necessary to move the movement selection lever towards the steering wheel. This shifting protects the lever from accidental operation.

With the movement selection lever in position other than "N", it is not possible to start the engine.

The movement selection lever, at the left of the steering wheel (fig. 150457-1), allows to set the direction of travel of the vehicle.

- Pull the lever towards the steering wheel and push it forward ("F" direction) to proceed forward.
- Pull the lever towards the steering wheel and pull it back ("R" direction) to proceed in reverse. When driving in reverse, an alarm sounds intermittently.

While holding the lever in an intermediate position "N" the transmission is in neutral and the vehicle is partially braked.

With the forward/reverse movement gear selection lever in position other than "N", the engine will not start.

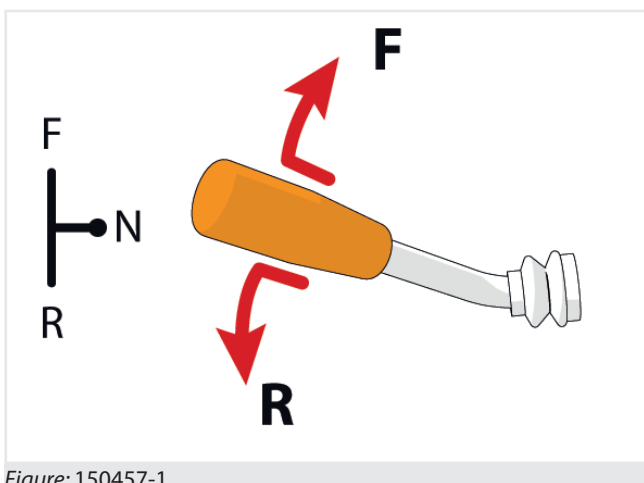

Figure: 150457-1

After selecting a direction of movement, the corresponding indicator lights on the instrument panel turn on:



"F" forward movement



"R" reverse movement

- While holding the lever in the intermediate "N" position the transmission is in neutral and both indicator lights will turn off.

The movements of the lever are not active when:

- The handbrake is engaged
- The operator is not properly seated in the driver's seat



NOTE

If the operator is not sitting properly in the driver's seat, the transmission is automatically switched off.

To continue moving the vehicle, the operator must sit in the driver's seat and set the movement selection lever in position "N".



WARNING

After selecting the vehicle movement direction, it starts suddenly to move in the selected direction.

Before selecting the movement direction make sure that nobody is standing near the vehicle.



WARNING

It is dangerous to operate the movement selection lever with the engine at high rpm or at a speed higher than 2 km/h (1.2 mph).

Before reversing the direction of movement, minimize the engine speed and select the new direction. Danger of vehicle overturning severe breakage of mechanical parts.

7.10.3 - Maximum speed limitation



NOTE

In high boom conditions (approx. 2 metres above the ground), the shifting speed is limited

7.10.4 - Mechanical transmission

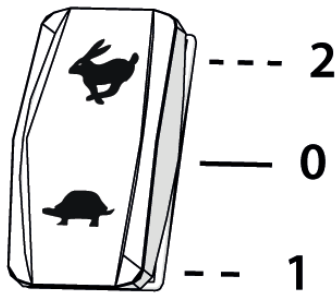

Figure: Fig. 180409-1

The button (fig. 180409-1) allows changing the manual gear shift.

Shift the slow gear (tortoise) to operate on the work site.

Shift the fast gear (hare) for long trips with no load, at clear work sites, with good visibility, in the absence of obstacles, with consistent and level ground floor, without transit of people.

To change the manual gear shift:

- Stop the vehicle completely.
- Press and hold down the service brake pedal.
- Press the button (fig. 180409-1) for a few seconds:
 - Down to shift the Slow gear, the related indicator light on the instrument panel turns on to indicate its selection.
 - Up to shift the Fast gear, the related indicator light on the instrument panel turns on to indicate its selection.
- Wait that the related indicator light turns on.
- Release the brake pedal.
- Drive slowly and gradually to allow the gear to fit properly.



WARNING

Risk of damage to the transmission.

Do not attempt a U-turn when the speed is higher than 30 Km/h. If incorrectly requested by the operator, it will trigger an acoustic and visual warning (error code) for a few seconds.

7.10.4.1 - Manually disable off the 2-gear hydrostatic transmission



DANGER

Deactivate the traction only in case it is necessary to tow the vehicle in case of damage to the engine and/or transmission.

In case it is necessary to tow the vehicle with the engine and/or transmission failure, it is possible to manually disable the transmission.

Carry out the following operations:

- Make sure that the vehicle engine is turned off
- Place chocks under the wheels to prevent sudden movements of the vehicle
- Turn the lever of the hydraulic valve (fig. 150745-1), to turn off the hydraulic supply to the reduction gear (the valve is located under the vehicle, near the reduction gear).

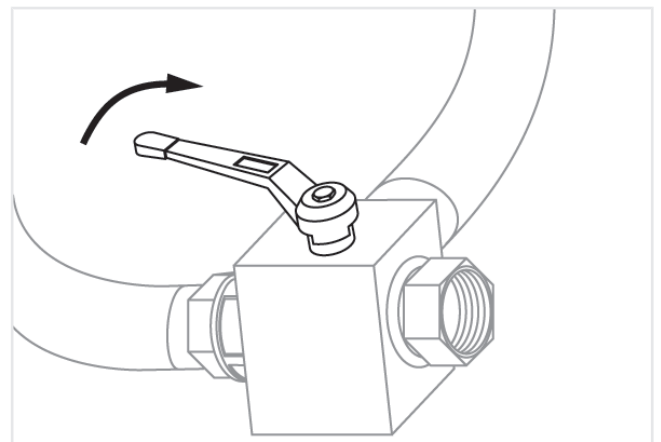

Figure: 150745-1

DANGER! Rotating the handle a jet of oil under pressure may leak out from the valve. Use appropriate safety equipment to protect eyes and skin from hot oil under pressure.

- Using a screwdriver, move the gear selection pin in neutral, at half stroke "2" (fig. 150745-2)
- If possible, before towing the vehicle turn on the instrument panel and check that the indicator lights of the forward and reverse gear are off.

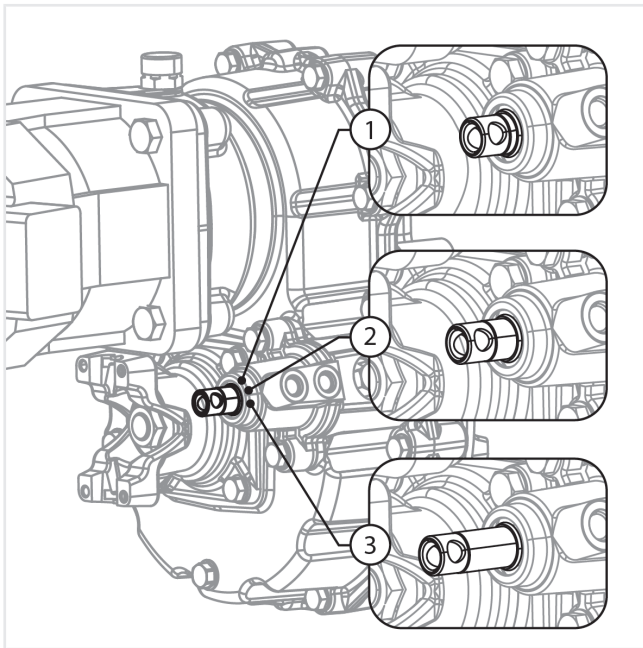

Figure: 150745-2



ATTENTION

Once the towing operations are completed open the valve again returning the lever (fig. 150745-1) to the starting position.

7.10.5 - Steering wheel

The steering wheel of the vehicle allows steering the vehicle wheels according to the steering mode set.



NOTE

Refer to the "Steering selector" chapter.



NOTE

The steering wheel is properly adjusted when the operator, with the back firmly against the backrest of the seat, is able to grasp the furthest side of the steering wheel while keeping the elbow slightly bent.

7.10.5.1 - Steering wheel tilt adjustment

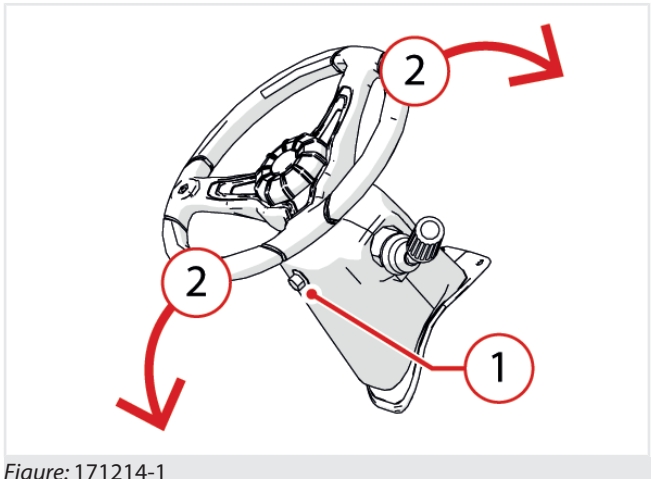

Figure: 171214-1

To adjust the steering wheel tilt (fig. 171214-1):

- Press and hold the button "1",
- Tilt the steering wheel to the desired position "2",
- Release the button "1" to lock the steering wheel.

7.10.6 - Horn

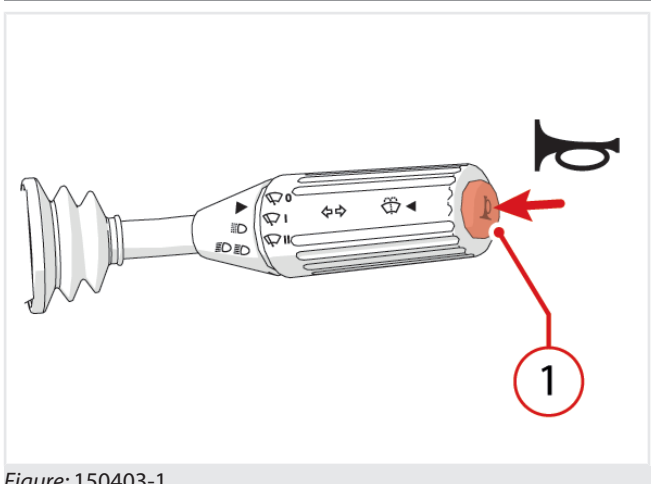

Figure: 150403-1

Press the button on the end of the lever "1" (fig. 150403-1), to activate the horn.

7.10.7 - Steering selector lever

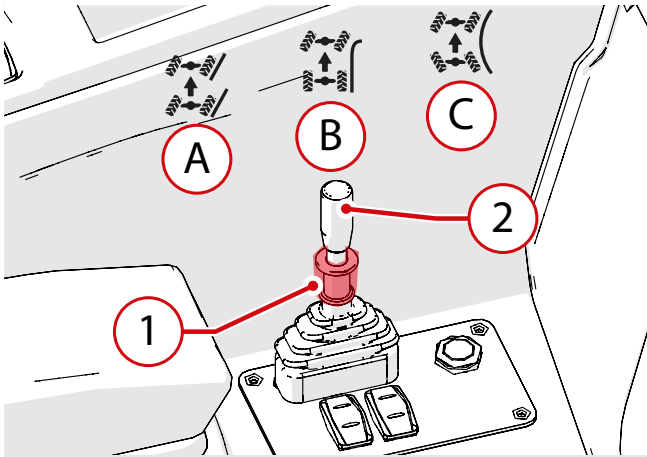

Figure: 150313-1

The steering selector lever (fig.150313-1) is used to change the steering mode of the wheels:

The steering selector lever is equipped with a locking device to prevent accidental operation. In order to move the lever "2" it is necessary to raise and keep the lock "1" raised. Release the lock "1" to fix the lever "2" in the chosen position:

A - Transverse

This type of steering allows a transverse or crab steering, so as to have a lateral displacement of the vehicle.

B - Front-steering wheels

This type of steering allows to carry out a steering with only the 2 front wheels.

C - Four steering wheels

This type of steering allows to carry out the steering with all 4 wheels, so as to have the smallest turning radius possible.



DANGER

Make the steering selection only with the vehicle stopped.

Before selecting a new type of steering, align the wheels with stopped vehicle.



WARNING

When the transverse steering is selected, always operate at low speed.



ATTENTION

For road travel, it is mandatory to select the 2-wheel steering mode.

Manual wheel alignment



ATTENTION

Perform the wheel alignment periodically (every 8-10 hours) depending on the continuous use of the vehicle.

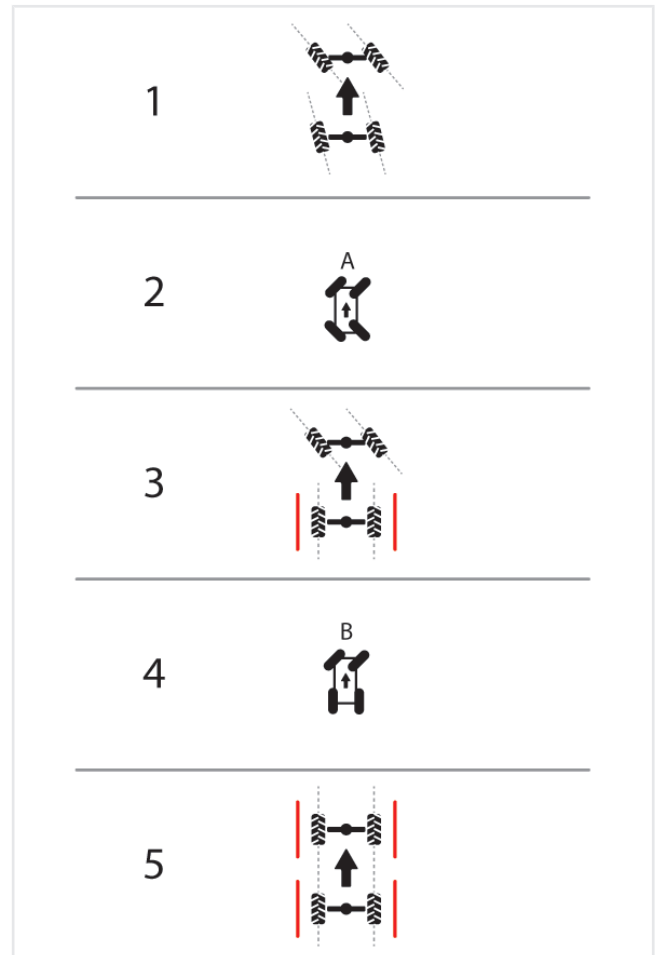

Figure: 150312-2

During normal use of the vehicle, frequently changing the steering modes, it is possible that the wheels are no longer perfectly aligned with each other.

To perform a proper wheel alignment, perform the following steps:

1. Stop the vehicle on a level ground.
2. Select the **A** or **C** steering mode
3. Turn the steering wheel until the rear wheels are aligned to the vehicle.
4. Select the **B** steering mode
5. Turn the steering wheel until the front wheels are aligned to the vehicle.

Try to move slowly for a few meters to verify that the vehicle travels properly in a straight line.

If at the end of the alignment the vehicle still does not proceed in a straight line, repeat the wheels alignment

7.10.8 - Wheels alignment check *



NOTE

* The wheels alignment check is an optional accessory.



ATTENTION

Perform the wheel alignment periodically (every 8-10 hours) depending on the continuous use of the vehicle.

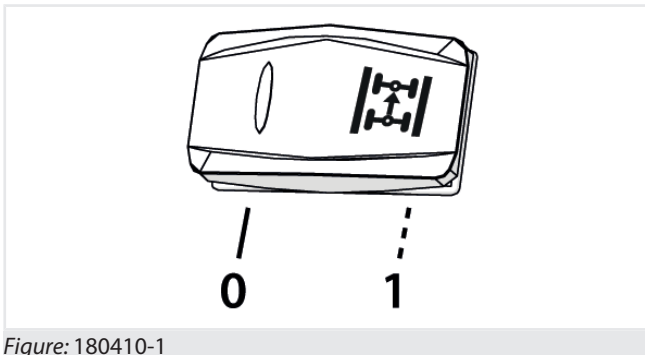

Figure: 180410-1

During normal use of the vehicle, frequently changing the steering modes, it is possible that the wheels are no longer perfectly aligned with each other.

The wheels alignment check allows to quickly and accurately align the wheels.

To align the wheels using the Wheels alignment check function, it is necessary to (fig. 180410-1):

- Stop the vehicle on a level ground.
- Select the 4-wheel or transverse steering mode.
- Press the button on side "1".
- Hold down the button and turn the steering wheel to bring the rear wheels aligned to the vehicle, until the light "Rear wheels aligned" comes on.
- Select the 2 front wheel steering mode.
- Press the button on side "1".
- Hold down the button and turn the steering wheel to bring the rear wheels aligned to the vehicle, until the light "Front and rear wheels aligned" comes on.

Now the wheels alignment is complete.

7.10.9 - Parking brake

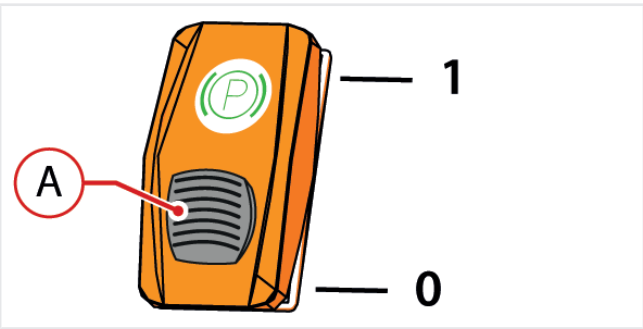

Figure: 150454-1

To engage the parking brake, lift the block "A" and simultaneously press the switch on the side "1" (fig. 150454-1).



150454-2



150454-3

The parking brake properly engaged is indicated by the lighting of the switch and by the indicator on the instrument panel of the vehicle (fig. 150454-2).

With the parking brake engaged, the vehicle cannot move; the hydrostatic transmission is switched off and the wheels are braked.

To disengage the parking brake, press the switch from side 0.

The parking brake must be engaged:

- Every time the operator leave the vehicle, even in case of momentary stop
- Whenever the vehicle operates from a standstill even with outriggers down (if any)
- To start the engine

The brake engages automatically when the engine is stopped.



WARNING

Unauthorised modification of axle ratios, vehicle weight, size of wheels and tyres can affect the parking brake efficiency.



NOTE

To verify the parking brake efficiency contact a **DIECI** authorised workshop.



DANGER

DANGER: In case of failure of the parking brake do not use the vehicle.

If the warning light (fig. 150454-3) turns on intermittently, it indicates a low brake fluid level.

If the warning light (fig. 150454-3) turns on in a fixed way, the parking brake is stuck or damaged.

Do not use the vehicle until the problem has been solved. Contact a *Dieci* service centre.

7.10.9.1 - Deactivating the internal parking brake manually

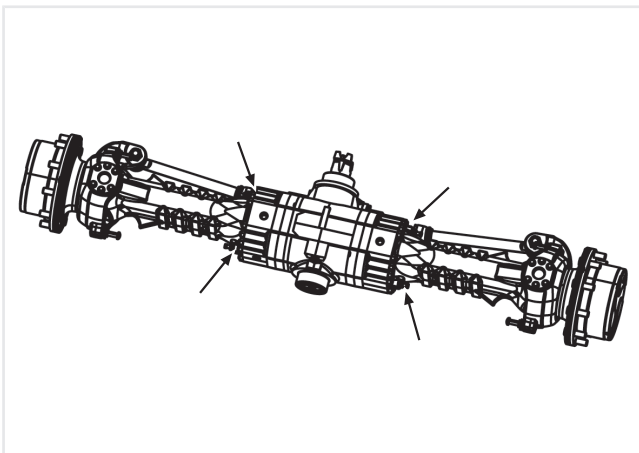

Figure: 150563-1

The parking brake must be disengaged directly on the axle to allow the vehicle to be towed.

- Place safety wedges under the wheels to prevent the vehicle from moving suddenly
- Loosen the lock nuts on both sides of the central body of the axle.
- Tighten the screws until they meet resistance; check the turns made in order to return the screws into the starting position when the towing operations are completed.
- Tighten the screws further 1.5 turns.
- In this way the brake will be released. After the towing return everything to the initial conditions.

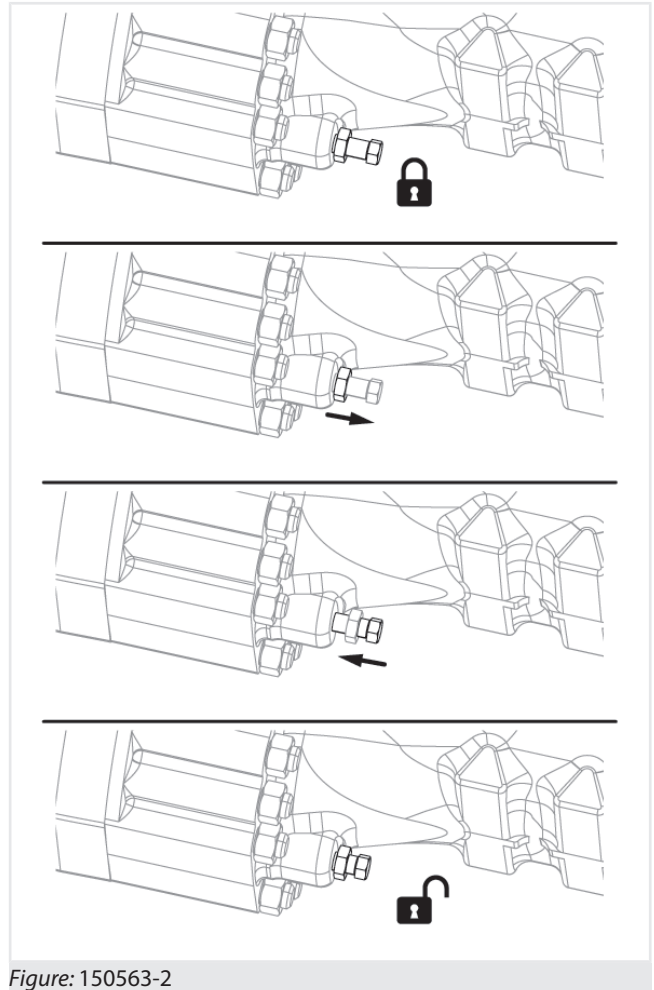

Figure: 150563-2



DANGER

Never use the vehicle with the negative parking brake disengaged/disconnected.

After the towing return everything to the initial conditions.

It is very important to re-tighten the screws with the same number of turns with which they are loosened.

7.10.10 - Service braking pedal

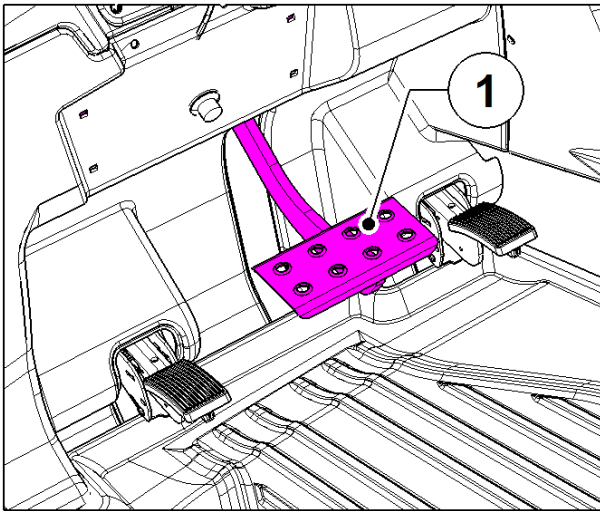

Figure: 150311-1

Press the service brake pedal "1" (fig. 150311-1) to slow down or stop the vehicle.

The pedal acts directly on the service brakes inside the differential axles.

When the brake pedal is pressed the stop lights of the rear lights go on. The lights remain in operation until the pedal is released.

Periodically check that both lights are working.



150311-2



WARNING

In the case of restricted use of the pedal periodically check its proper operation. In case of problems contact the *Dieci* service centre.



DANGER

If the warning light (fig. 150311-2) turns on intermittently, it indicates a low brake fluid level.

If the warning light (fig. 150311-2) turns on in a fixed way, the parking brake is stuck or damaged.

Do not use the vehicle until the problem has been solved. Contact a *Dieci* service centre.

7.10.11 - Inching Pedal

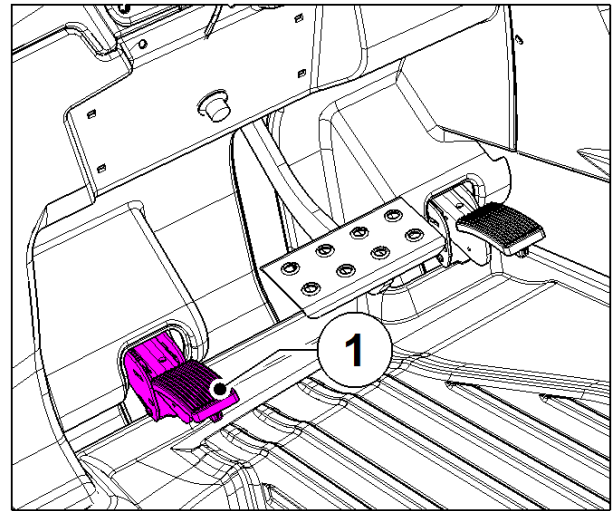

Figure: 150740-1

The inching pedal "1" (fig. 150740-1) acts directly on the hydrostatic transmission and allows to slow down the vehicle forward movement.

The pedal allows slow and precise forward movements with high rpm heat engine.

With pedal fully pressed, the vehicle stops the forward movement.



DANGER

Do not press the inching pedal at high speeds, the vehicle brakes suddenly and the diesel engine risks over-revving.

7.10.12 - Accelerator pedal

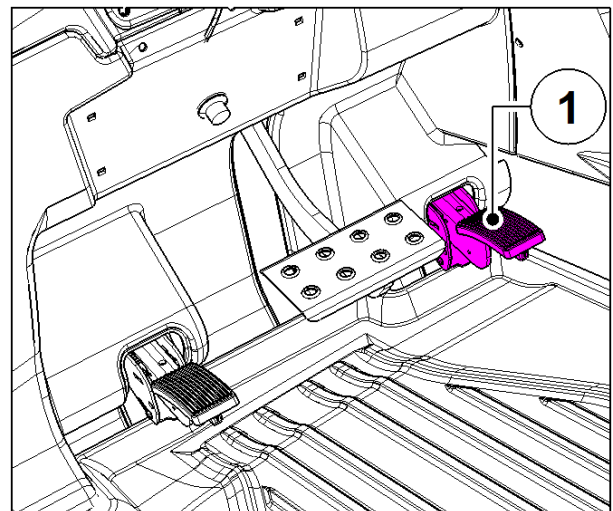

Figure: 150741-1

Press the accelerator pedal "1" (fig. 150741-1) to increase the engine speed, when the pedal is released the engine rpm will decrease.

The pedal acts directly on the injection pump of the engine.



WARNING

If while driving, the vehicle exceeds the maximum allowed speed, the "Over speed protection" transmission electronic control goes into operation. The function automatically limits the vehicle speed in order to prevent transmission and diesel over revving. Triggering of the "Over speed protection" function is signalled by the general alarm warning light switching on and the intermittent acoustic signal.

If the function intervenes, the operator must lift his foot from the accelerator pedal and reduce the speed of the vehicle.



NOTE

The maximum speed of the vehicle varies with the inflation pressure and the size and wear of the tyres.

Pressing the accelerator pedal only determines the travel speed linked to the engine rpm set via the hand throttle.

In order to raise (or lower) the engine rpm, it is necessary to press the switch several times; keeping it pressed will not change the engine rpm.



NOTE

The hand throttle is only deactivated when the diesel engine is taken back to Low value.

7.11 - Diagrams notebook

The diagrams notebook (fig. 150462-1) summarizes the main information for safe use of the vehicle for easy reference by the operator during the various processing phases.

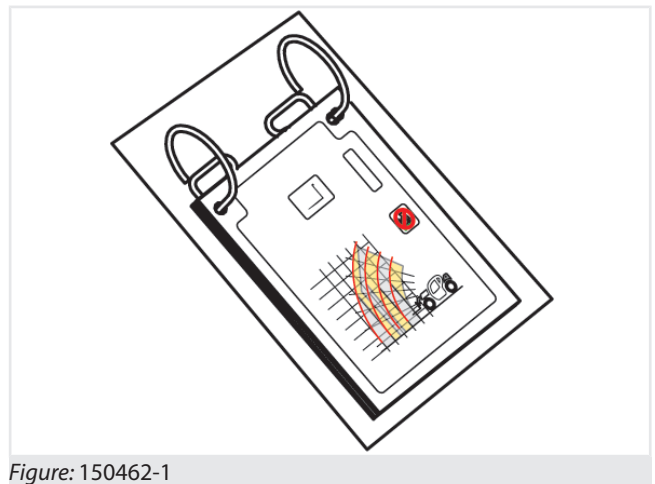

Figure: 150462-1

7.10.13 - CREEP mode

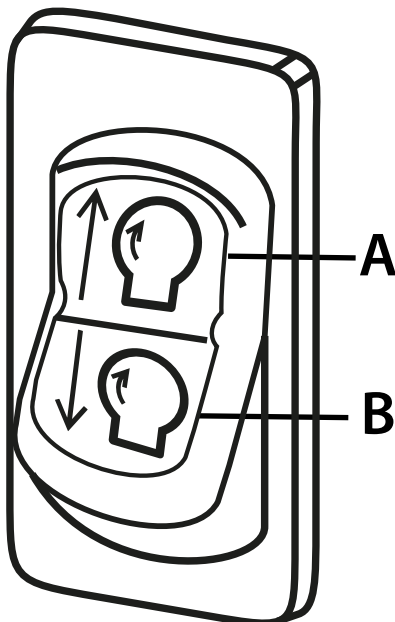

Figure: 180362-1

To activate the CREEP mode, with the machine at a standstill, press the switch (fig. 180362-1), on the upper side "A" to increase the engine rpm; press it on the lower side "B" to lower engine rpm.

7.11.1 - Load Charts

The Safe Working Load (SWL) of the vehicles depends on the extension extent and the boom angle.

The load charts show the maximum height and extent allowed by certain equipment and loads, in order to work safely, without the risk of tipping of the vehicle during work operations.

This vehicle is however equipped with an anti-tipping device that monitors in real time the status of the load and the risk of tipping of the vehicle (see the "Anti-tipping device" chapter in the vehicle manual). It is however necessary to use and adhere to the load charts in relation to the load and type of accessory used.



ATTENTION

It is mandatory to have in the cab, the load chart referred to the equipment and the vehicle that is being used.

Refer to the correct load chart before handling a load.



DANGER



Danger of tipping.

Do not raise or extend the boom when the vehicle is in motion. Fully lower and retract the boom before moving a load.



ATTENTION

The load charts refer to stopped and leveled vehicle.



ATTENTION

The diagrams of the vehicle and equipment being used must always be present in the Diagram notebook found in the cab, used by the operator.

Replace the load charts if they deteriorate, are damaged or lost.

The load charts are ordered just like spare parts (make sure you provide the relative identification code when placing the order).

Before handling a load it is necessary to:

- Have read and understood the use and maintenance manual of the vehicle and equipment.
- It is mandatory to know the weight of the load that must be handled.
- Locate the center of gravity of the load to be moved. The center of gravity may not be at the center of the load.

7.11.1.1 - Read the load charts

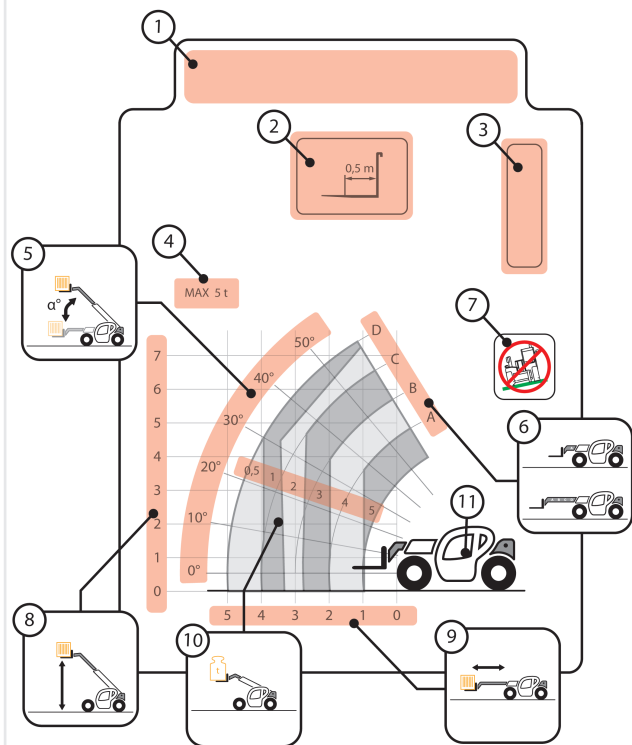

Figure: 150464-1 - Load Chart

1	Vehicle name and model
2	Equipment model Equipment model with the indications of center of the load. For more information, see the Equipment legend for load charts [▶ 104] chapter.
3	Load Chart code
4	Equipment maximum capacity The maximum Capacity of the equipment is also reported by the sticker placed on the equipment itself.
5	Boom angle The boom angle is indicated by the inclinometer on the left side at the end of the boom (if any), or on the display of the anti-tipping device (if present).
6	Boom extension The boom extension is indicated by letters of the alphabet ("A", "B", "C", "D", etc...). The same letters are shown as stickers on the boom extension, so that the user in the cab can know the boom extension by reading the letters on it.
7	Vehicle operating mode For more information, see the Operating modes legend for load charts [▶ 104] chapter.
8	Load height from ground

9	Horizontal distance of the vehicle load
10	Load weight
11	Vehicle position

7.11.1.2 - Use the load charts

The Load charts indicate the areas in which it is possible to operate with the vehicle and load in safe conditions.



DANGER



Danger of tipping.

Operating the vehicle without observing the Load charts related to the equipment installed may result in hazardous conditions, up to the tipping limit and the operation of the Anti-tipping device.

The whole working area of the boom is divided into these areas (position "1", fig. 150465-1). Each area corresponds to a maximum capacity. The area closest to the vehicle will have a capacity equal to the maximum loading capacity of the vehicle; as moving away from the vehicle, the maximum capacity of the areas decreases.

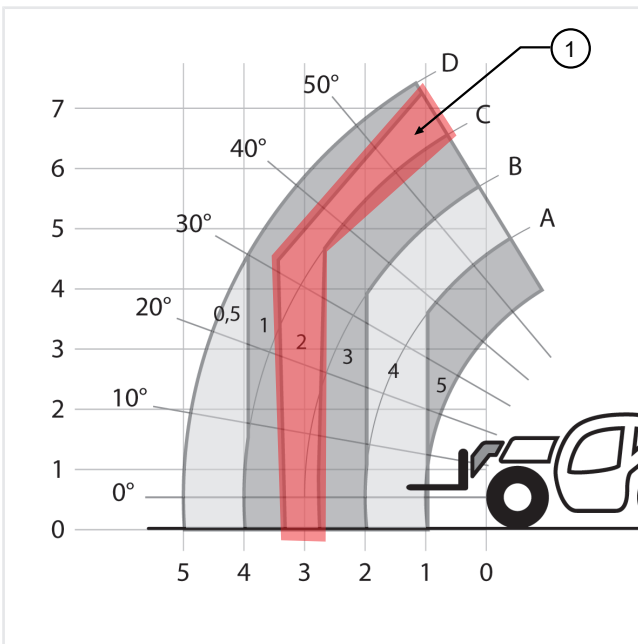

Figure: 150465-1

Before starting to work, it is necessary to know:

- Load weight
- Height from ground at which the load must be handled
- Distance from the vehicle at which the load must be handled

Locate the area of the load charts, showing a value just above the weight of the load to be handled; for example if the load should weigh 1.5 tons, the area to which it is necessary to refer is the area with a capacity of 2 tons (position "1").

Knowing the area, the following will be known:

- the vertical and horizontal distance to which it will be possible to handle the load
- the boom extension and angle values at which it is possible to operate.

In order to know the vertical and horizontal distance to which it will be possible to handle the load, use the horizontal and vertical lines that cross the reference area; for example, it will be possible to carry the load at a distance of 3 m from the vehicle and 4 m in height remaining in safety conditions (position "2", fig. 150465-2).

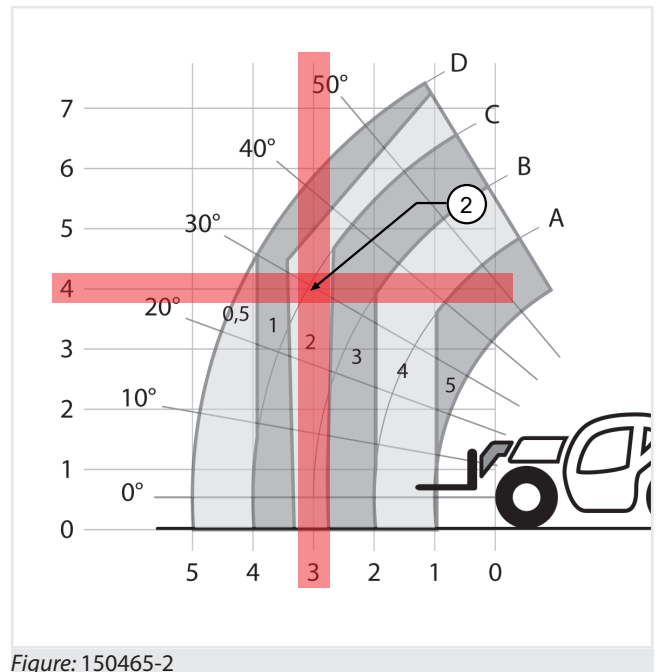

Figure: 150465-2

To avoid operating in conditions of tipping danger, use the boom angle and extension indications. For example, we could operate with the boom extended to letter C at an angle of 30° (position "3", fig. 150465-3).

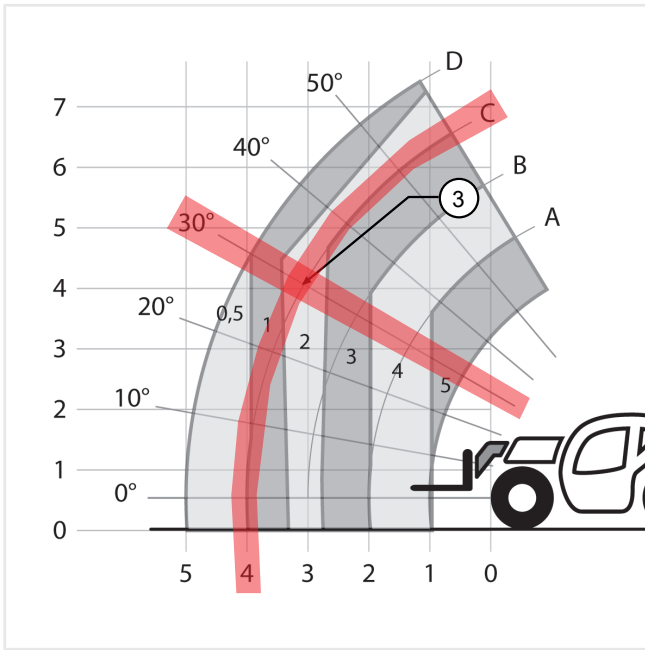

Figure: 150465-3



DANGER



Taking the load beyond the permissible area, we would enter in danger conditions of tipping over and the anti-tipping device, locking all the movements considered aggravating to the stability of the vehicle and of the load.

Use the load charts for each load handling to determine the working area.

It is possible to start operating only under safety conditions and if within the predetermined safe work area.

7.11.1.3 - Equipment legend for load charts

	Forks xxx = Center of gravity of the load
	Forks Spreader / Shifter xxx = Center of gravity of the load
	Winch xxx = Capacity
	Crane extension xxx = Center of gravity of the load
	"Gooseneck" jib (Dimensions) xxx = Center of gravity of the load

	Hook for fork carrier plate
	Gripper for pipe with pipe locker xxx = Center of gravity of the load
	Cylinders manipulating gripper
	Wheels manipulating gripper
	Sheets holding gripper
	5 teeth orange-peel grabber
	Centering layer
	Negative jib
	Positive jib
	Fixed front basket xxx = length, yyy = width
	Extensible front basket xxx = length, yyy = width, zzz = maximum width
	Fixed trilateral basket xxx = length, yyy = width
	Extensible trilateral basket xxx = length, yyy = width, zzz = maximum width
	Front basket for tunnels xxx = length, yyy = width
	Fixed trilateral basket for tunnels xxx = length, yyy = width

7.11.1.4 - Operating modes legend for load charts

	Prohibited to work on tires
--	-----------------------------

	Prohibition of operating with unlevelled vehicle
	Crossbeam outriggers lowered, 0% extended
	Crossbeam outriggers lowered, 50% extended
	Crossbeam outriggers lowered, 100% extended
	Crossbeam outriggers lifted
	Flap down outriggers lifted
	Flap down outriggers lowered
	On wheels
	Front position
	In non-continuous Rotation
	In continuous Rotation

7.12 - Boom control

7.12.1 - Joystick

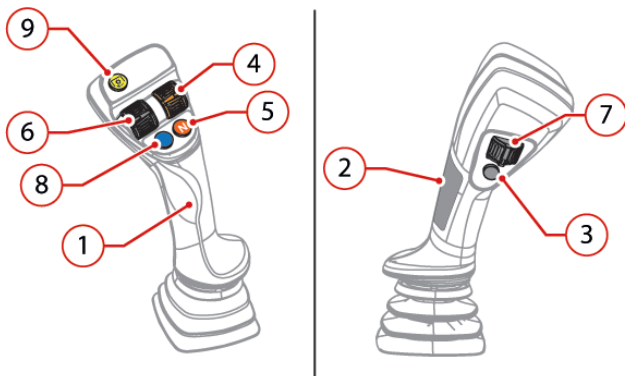

Figure: 171225-1: Joystick description

1 Grip	2 Deadman sensor
3 Deadman button	4 FNR roller
5 Neutral button	6 Extension roller
7 Services roller	8 Hydraulic sockets change button *
9 Continuous oil function button	

* Components depending on optional equipment or pre-arrangements.

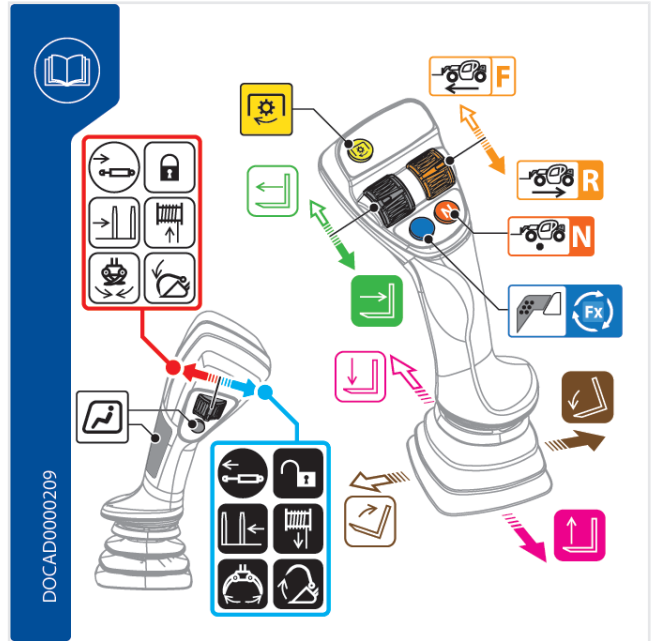



Figure: 180301-1: Instructions for using the joystick

7.12.1.1 - Grip



	Description
	Boom lifting: Move the joystick handle backwards.
	Boom lower: Move the joystick handle forward.
	Tilting downwards: Move the joystick handle to the right.
	Tilting upwards: Move the joystick handle to the left.

7.12.1.2 - FNR roller

	Description
	Forward gear (F) Refer to FNR commands on joystick [▶ 93]

Description	
	Neutral (N) Refer to FNR commands on joystick [93]
	Reverse (R) Refer to FNR commands on joystick [93]

7.12.1.3 - Extension roller

Description	
	Boom retraction: Move the extension roller backwards.
	Boom extension: Move the extension roller forward.







7.12.1.4 - Services roller







NOTE

It is possible to connect different equipment and tools with different applications to the hydraulic sockets dedicated to the services.

Refer to the equipment or tool manual to know its correct operation and its controls.

Description	
	Cylinder extension: Move the services roller to the right.
	Block opening: Move the services roller to the right.
	Shifting to the right: Move the services roller to the right.
	Winch rope lifting Move the services roller to the right.
	Grippers closing: Move the services roller to the right.
	Bucket closing: Move the services roller to the right.
Description	
	Cylinder extension: Move the services roller to the left.

Description	
	Block opening: Move the services roller to the left.
	Shifting to the left: Move the services roller to the left.
	Winch rope descent: Move the services roller to the left.
	Grippers opening: Move the services roller to the left.
	Bucket opening: Move the services roller to the left.

7.12.1.5 - Deadman function: Capacitive sensor

Description	
	The deadman joystick function prevents any accidental movements.

The Joystick features a "deadman" capacitive sensor: to enable it to function you need to place your hand on the grip "1" (fig.171225-1), correctly so as to activate the capacitive sensor "2".

If your hand is not resting on the capacitive sensor "2", boom movements are disabled.

Adjust the seat and the armrest so you can hold the joystick correctly (fig. 150450-2).

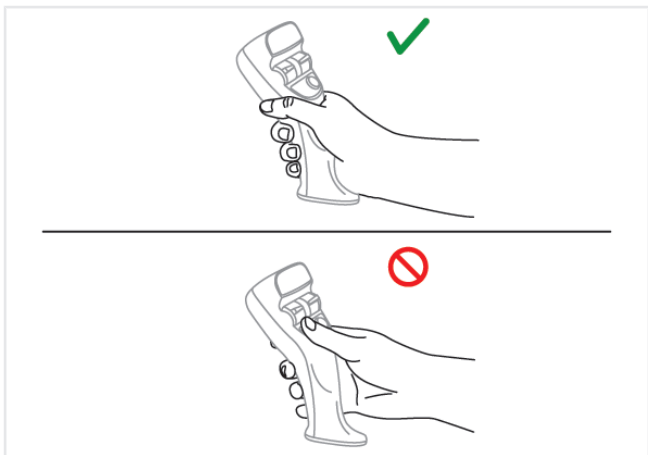



Figure: 150450-2

7.12.1.6 - Deadman function: Button

Description	
	The deadman joystick function prevents any accidental movements.

To enable the joystick controls it is necessary to keep the deadman button "3" pressed (fig. 171225-1).

The deadman function use by means of a button or by a capacitive sensor of the handle are the same.

7.12.1.7 - Continuous oil function for sockets on boom head *

Description	
	Continuous oil function.

The continuous oil function allows to maintain a constant volume of oil passing through the hydraulic sockets without acting consistently on the selector of the joystick.



ATTENTION

With the continuous oil function enabled, do not move away from the vehicle.

Always stay within reach of the emergency stop button to stop all vehicle movements in an emergency.



NOTE

With the continuous oil function active it is still possible to use the joystick to move the boom.

When light of button "9" is on, on the joystick, it indicates that the continuous oil function is active.

With the continuous oil function active, the selection of the hydraulic sockets [if present] is disabled.

Activation of continuous oil function with vehicle in motion

Perform this procedure in case of work that requires the operator sitting in the cab and vehicle in motion.

To activate the function it is necessary to (fig. 180301-1):

- The operator must be seated correctly in the driver's seat,
- Hold the joystick "1",
- [If there are several optional hydraulic sockets] Select the desired hydraulic socket on which to activate the function,
- Use the services roller on the joystick "7" to set the desired flow of oil.

- Maintain the flow of oil through the services roller and simultaneously press the button "9" for at least 3 seconds to activate the continuous oil function.

To disable the function it is necessary to:

- Press the button "9".

The continuous oil function stops if the operator rises from the seat.

Activation of the continuous oil function with stationary vehicle

Carry out this procedure in case of work requiring stationary vehicle and operator near the vehicle but not sitting in the cab.

To activate the function it is necessary to (fig. 180301-1):

- The vehicle must be stationary and with parking brake engaged.
- The operator must NOT be seated correctly in the driver's seat,
- Hold the joystick "1",
- [If there are several optional hydraulic sockets] Select the desired hydraulic socket on which to activate the function,
- Use the services roller on the joystick "7" to set the desired flow of oil.
- Maintain the flow of oil through the services roller and simultaneously press the button "9" for at least 3 seconds to activate the continuous oil function.

When light of button "9" is on, on the joystick, it indicates that the continuous oil function is active.

With the continuous oil function active, the selection of the hydraulic sockets [if present] is disabled.

To disable the function it is necessary to:

- Press the button "9".

7.12.1.8 - Selection of hydraulic sockets on the boom head *

Description	
	Selection of hydraulic sockets on the boom head



NOTE

* The function of selecting hydraulic sockets on the boom head is an optional attachment.

The presence and number of hydraulic sockets and electrical contacts present on the boom head may vary depending on optional attachments.



DANGER

Danger of moving the wrong hydraulic socket.

Do not operate the hydraulic sockets using the joystick during the selection of the hydraulic socket. Make the selection of the hydraulic socket and use the joystick to control the hydraulic socket selected only at a later time.

After connecting the equipment to the hydraulic sockets before starting the job, check in a safe location that all the controls are working properly. During the test, be careful not to create danger or damage to persons, animals or things.

The hydraulic socket selection function is used to change the active hydraulic socket on the boom head.

Hold the joystick "1" (Fig. 171225-1) and press the Hydraulic socket change button "8". The active hydraulic socket on the head boom will switch to the next available hydraulic socket in a cyclic manner.

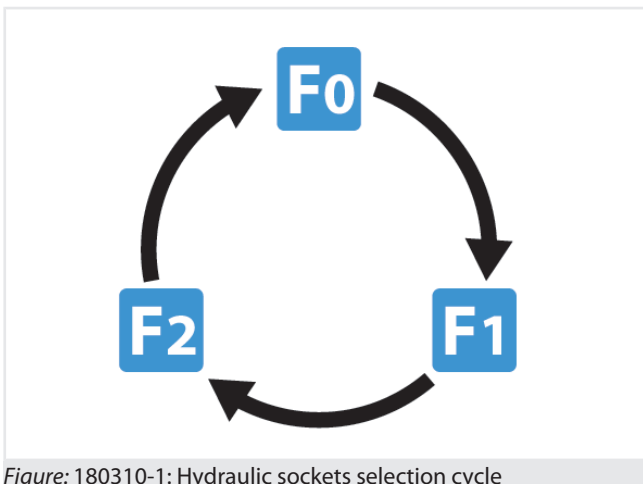

Figure: 180310-1: Hydraulic sockets selection cycle

The icon corresponding to the active hydraulic socket will be shown on the display.

Switching the vehicle off and on again, the active hydraulic socket will always be the default one (F0) and not the last one previously selected.

7.12.2 - Boom suspension *



NOTE

* The boom suspension is an optional accessory.

The switch boom suspension has a safety lock to prevent accidental activation.

To activate the boom suspension, move the block and simultaneously press the switch (fig. 150310-1).

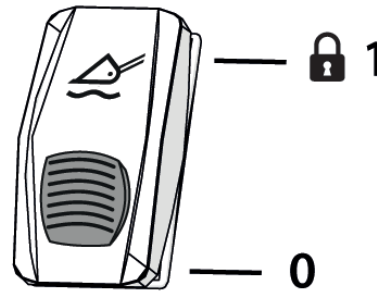

Figure: 150310-1

The indicator light on the display indicates that the function is active.



WARNING

The boom suspension works only if:

- Boom is down;
- Button is pressed;
- Vehicle speed is higher than 5 km/h

The boom suspension is automatically deactivated when the "dead man" function is activated on the joystick.

The suspension may also be used during the transport of loads, with the boom in transport position (fully retracted and in horizontal position).



WARNING

Activating the boom suspension, the boom may have a slight but sudden upward movement.

Before activating the boom suspension, make sure that the installed equipment and any load are properly secured to the vehicle and that there are no people, animals or objects within the operating range of the vehicle.



ATTENTION

The presence of the boom suspension does not involve the increase of the transport speed and vehicle movement. The speed must always be proportional to the ground, to the place of use and to the atmospheric conditions.



NOTE

The boom suspension is a device which entails an increase in the comfort of the vehicle, but it does not increase its safety characteristics.

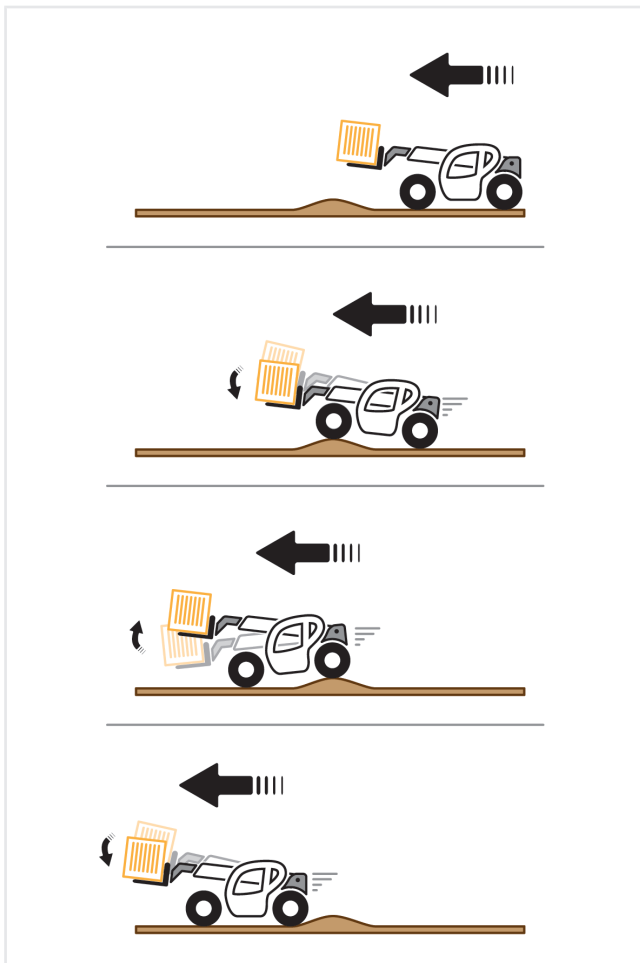

Figure: 150310-2

7.12.3 - Quick coupling *



NOTE

* The equipment quick coupling is an optional attachment.

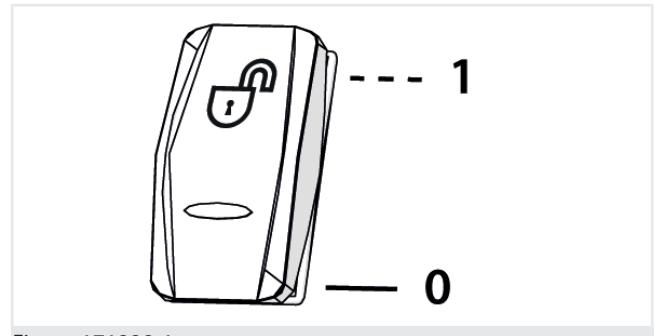

Figure: 171228-1

The equipment quick coupling allows the operator to install and fasten the equipment to the attachment holding plate directly from the cab.

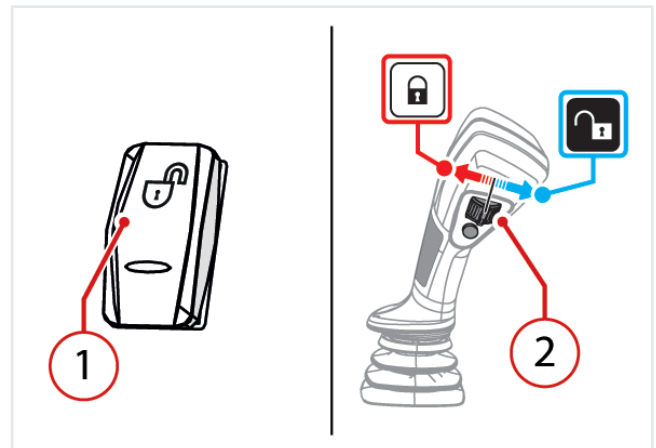

Figure: 171228-2

To use the quick coupling to install the equipment it is necessary to (fig. 171228-2):

- Carry out the normal hooking operations set out in paragraphs 1, 2, 3 and 4 of the chapter "Equipment installation".
- Press the Quick Coupling button "1" and at the same time operate the roller on the services joystick "2" to open the quick coupling.
- Keep the quick coupling open, tilt the plate upward to make sure that the equipment is fully resting on the attachment holding plate.
- Release the roller on the services joystick "2" and the Quick coupling button "1" to close the quick coupling and lock the equipment.
- If the equipment is not properly fastened, repeat the installation.



DANGER

Danger of load, equipment or tool falling.

Do not operate without having first properly fastened the equipment to the plate.

7.13 - Ventilation

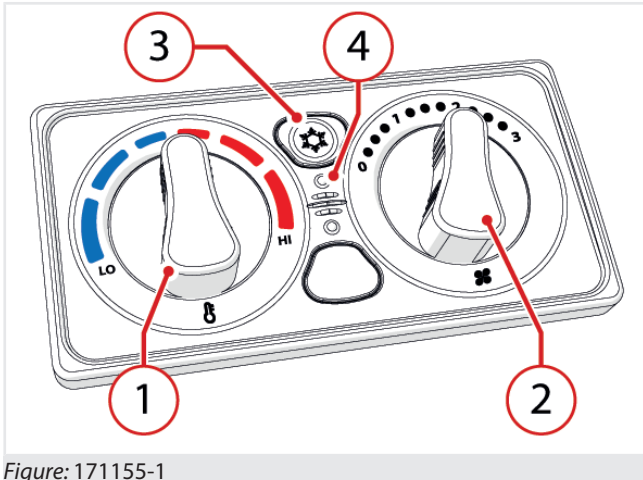

Figure: 171155-1

7.13.1 - Ventilation adjustment

To adjust the ventilation turn the knob "2" (fig. 171155-1).

Clicks indicate respectively:

- 0 - Off
- 1 - First speed
- 2 - Second speed
- 3 - Third speed

7.13.2 - Air temperature adjustment

To adjust the temperature of the air coming out of the vents, turn the knob "1" (fig. 171155-1):

- Turning the knob clockwise (in the red scale) the temperature increases.
- Turning the knob counterclockwise (in the blue scale) the temperature decreases until it is next to the outside temperature.

7.13.3 - Air conditioning *



NOTE

* Air conditioning is an optional accessory.

For a correct use of air conditioning, follow the following steps (fig. 171155-1):

- Check that all doors and windows are closed.
- Check that the heater is turned off by moving the lever towards the end of the blue scale.
- With the engine running, press the button "3" to turn on the air conditioning.
- Turn the knob to adjust the airflow "2" to select the desired intensity.

- Open and adjust the vents to obtain the best cooling according to the ambient temperature.
- Turn the temperature knob "1" to obtain the desired temperature.

The active air conditioning is signaled by the led "4" on (fig. 171155-1).



ATTENTION

Turn on the air conditioning two minutes, every 15 days, even in the colder seasons with the engine idling (without accelerating). In this way the moving parts, such as the compressor and the system in general are lubricated.

To keep the air conditioning system efficient keep the condenser clean.



DANGER

Do not loosen any hose of air conditioning systems in order to reach the capacitor since the contact between the skin and the refrigerant can cause frostbite.

For maintenance and deadlines, see the "Maintenance" chapter.

7.13.4 - Ventilation nozzles

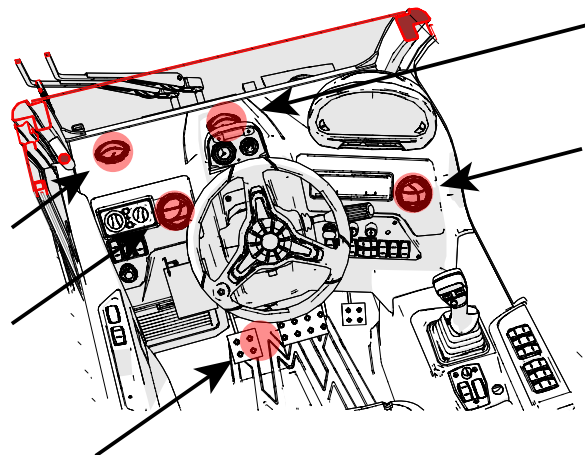

Figure: 171156-1

To open the air vents press on one side of these and adjust the air flow direction using the fins or rotating the vent.

To close the vents push the fins bringing them to the horizontal closing position.

7.14 - Levelling

7.14.1 - Spirit Level



NOTE

The levelling system may vary depending on the chosen configuration and set-up

The spirit level is located at the centre of the dashboard. It is used to verify the correct transverse levelling of the vehicle.

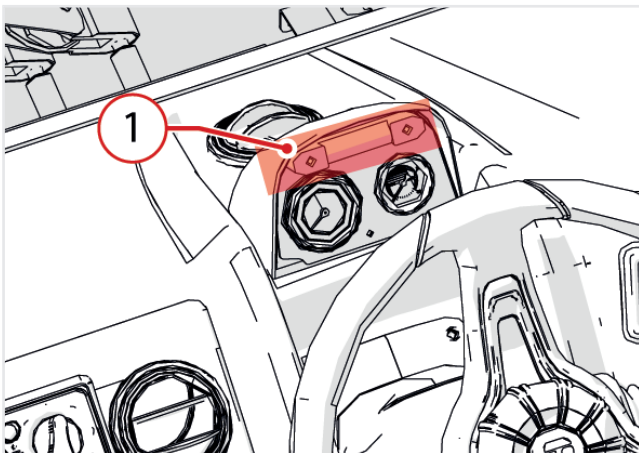

Figure: 171211-1

To safely operate, the spirit level must be at the centre, with a maximum approximation of 2° to the right or left.

In the standard spirit level, the angle exceeds 2° when the spirit level moves completely outside the 2 limit marks of 2°.



DANGER



DANGER OF TRANSVERSE TIPPING.

To safely operate, the spirit level must be at the centre, with a maximum approximation of 2° to the right or left.

7.14.2 - Transverse levelling *



NOTE

The transverse levelling device is an optional accessory.

The transverse levelling device allows to adapt the vehicle to the transverse inclination of the ground.

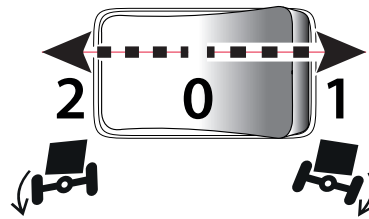

Figure: 171217-1

To level the vehicle it is necessary to:

- Position the load on the ground.
- Lower and fully retract the telescopic boom.
- Press the transverse levelling device button (fig. 171217-1):
 - From the right side "1" to tilt the vehicle to the right.
 - From the left side "2" to tilt the vehicle to the left.



DANGER



It is not possible to work with tilting greater than 2°. Danger of transverse tipping.

Use the spirit level in the cab to check the inclination of the vehicle.



DANGER

It is not possible to level the machine when the attachment holding plate is more than 2 meters high. Danger of transverse tipping. With the man basket connected, level the machine only when the boom is retracted and lowered.

7.15 - Outriggers *

7.15.1 - Outriggers warnings



NOTE

The Outriggers are present on the vehicle according to the model or of optional attachments.

The Outriggers feet allow to increase the stability of the vehicle during the working operations.

When using the vehicle with outrigger feet properly lowered, use the relative load charts.



WARNING



Danger of transverse tipping.

It is allowed to operate only if the vehicle transverse inclination is less than 2°.



DANGER

The sinking of the feet leads to the destabilization of the vehicle or of the load and consequent danger of vehicle tipping or load falling.

Before lowering the outrigger feet, place the vehicle in working position, make sure that the ground is firm and can support the weight of the vehicle without the outrigger feet sinking into the ground. See the chapter "Assessing the consistency of the work ground".



ATTENTION

Before proceeding with the transfer on road, lift and retract completely all outriggers.



NOTE

It is allowed to move the outriggers only with boom retracted at a height lower than 2.5 m (8.2 ft).

Only for vehicle with man basket pre-arrangement, it is possible to move the outriggers with the boom extended not more than 500 mm (19.69 in) and at a height less than 2.5 m (8.2 ft).

7.15.2 - Outriggers movement

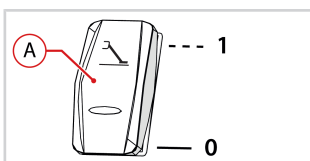

160615-1

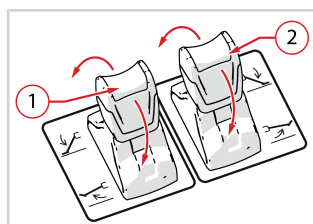

160615-2

To move the outriggers it is necessary to use the levers "1" and "2" (fig. 160615-2) located on the right instrument panel.

The controls are proportional compared to the outriggers movement.

- Lay the load on the ground.
- Lower and fully retract the telescopic boom.

- Press the button "A" to enable the use of levers "1" and "2".
- Press and hold down the button "A" to enable the outriggers movement and use:
 - The lever "1" to move the left outrigger.
 - The lever "2" to move the right outrigger.
 - Move the levers forward to lower the outriggers.
 - Move the levers backward to lift the outriggers.
- Check the correct leveling of the vehicle using the spirit level in the cab. The vehicle is correctly positioned on the outriggers when:
 - Both outriggers are lowered to the ground.
 - Both front wheels are off the ground.
 - The vehicle has a transverse slope less than 2°.



NOTE

The Outriggers icon on the vehicle display has different statuses.

Refer to the chapter: Outriggers icon * [▶ 86].

7.16 - Optional attachments

7.16.1 - Fan reversal *



NOTE

The fan reversal is an optional attachment.

The fan reversal allows precisely the radiator fan reversal to clean the radiator from any dirt deposits such as dust and straw.

The reversal is carried out automatically every 20 minutes, without having to stop the vehicle.

To activate the fan reversal manually operate on the dedicated button "1" (fig. 150306-1). The cleaning cycle is activated automatically pressing the button, which should therefore not be held down. The automatic fan reversal timer is also reset when the button is pressed.

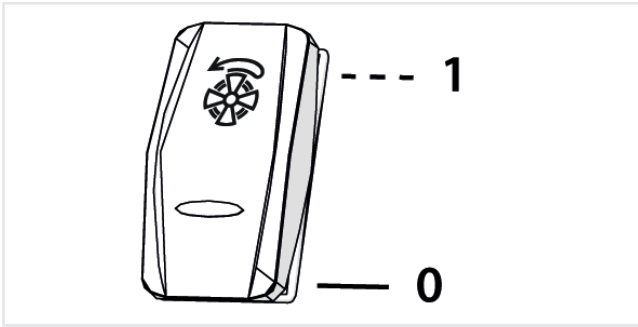

Figure: 150306-1

The fan will remain in the "cleaning" position (reversed motion) for a time set by the manufacturer.



ATTENTION

The fan reversal presence does not exempt the user from cleaning the fan, radiator and engine compartment, at the intervals indicated by regular maintenance.

7.16.2 - Pressure relief from hydraulic sockets *

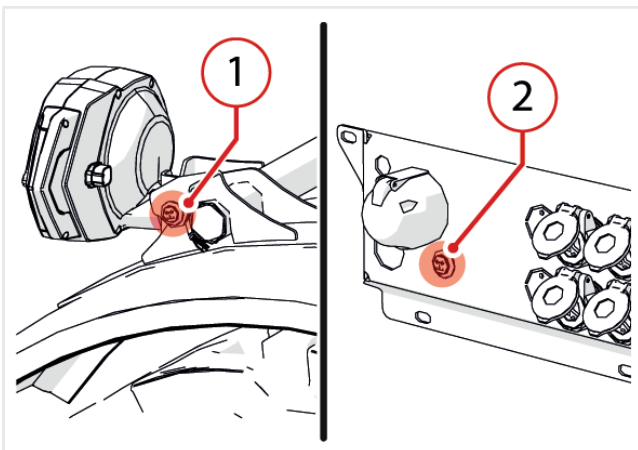

Figure: 180446-1

To facilitate the installation and removal of connections to the hydraulic sockets, it is possible to use the pressure relief from the hydraulic sockets.

Press the button "1" (fig. 180446-1) located on the left front light support for a few seconds to release pressure from the hydraulic sockets on the boom head.

If there are several hydraulic sockets, the pressure relief occurs cyclically at each activation of the button "1" (fig. 180446-1).

If present, press the button "2" (Fig. 180446-1) on the back of the vehicle for a few seconds to release pressure from the rear hydraulic sockets.

If there are several hydraulic sockets, the pressure relief occurs cyclically at each activation of the button "2" (fig. 180446-1).



NOTE

Pressure can also be released by pressing the button shown in fig. 150309-1.

7.16.3 - Rear hydraulic sockets *



NOTE

* The presence and number of rear hydraulic sockets present on the vehicle may vary depending on the optional equipment.

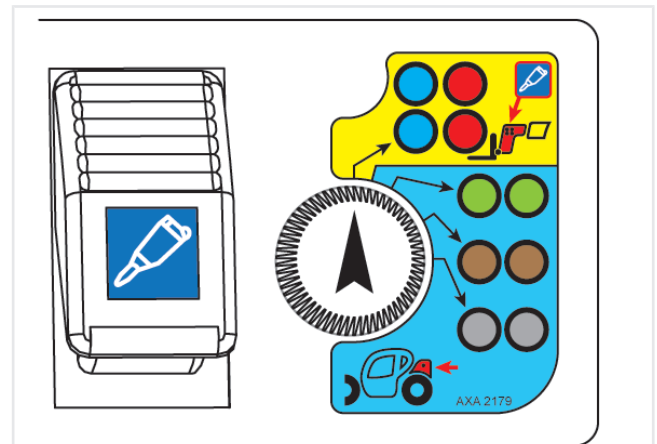

Figure: 150202-1

The hydraulic sockets switch allows to select which hydraulic sockets must be operated by the joystick and is present only on vehicles that are equipped with rear hydraulic sockets and on the telescopic boom head.

Turn the knob "1" (fig. 150202-1) to activate the different hydraulic sockets on the vehicle:

- A - Sockets on boom head
- B - Rear Green sockets
- C - Rear Brown sockets
- D - Rear Gray sockets

The selection of any optional outlets located on the boom is performed with the hydraulic sockets on the boom head "2" - See the next chapter.



NOTE

If there are no rear brown and gray sockets, if selected through the knob "1", the green socket will be activated.

**DANGER****Danger of moving the wrong hydraulic socket.**

Do not operate the hydraulic sockets using the joystick during the selection of the hydraulic socket. Make the selection of the hydraulic socket and use the joystick to control the hydraulic socket selected only at a later time.

After connecting the equipment to the hydraulic sockets before starting the job, check in a safe location that all the controls are working properly. During the test, be careful not to create danger or damage to persons, animals or things.

**WARNING**

Pay attention to the connections of the hydraulic socket: moving the service lever placed on the joystick forward, towards the open padlock (see Joystick chapter) oil will be sent to the sockets marked with the symbol "+".

7.17 - Remote Control *



NOTE

* The Remote control is an optional accessory.



NOTE

There are two types of remote controls, depending on the chosen vehicle configuration:

- Remote control with levers
- Remote control with joystick

7.17.1 - Remote control with levers: Description

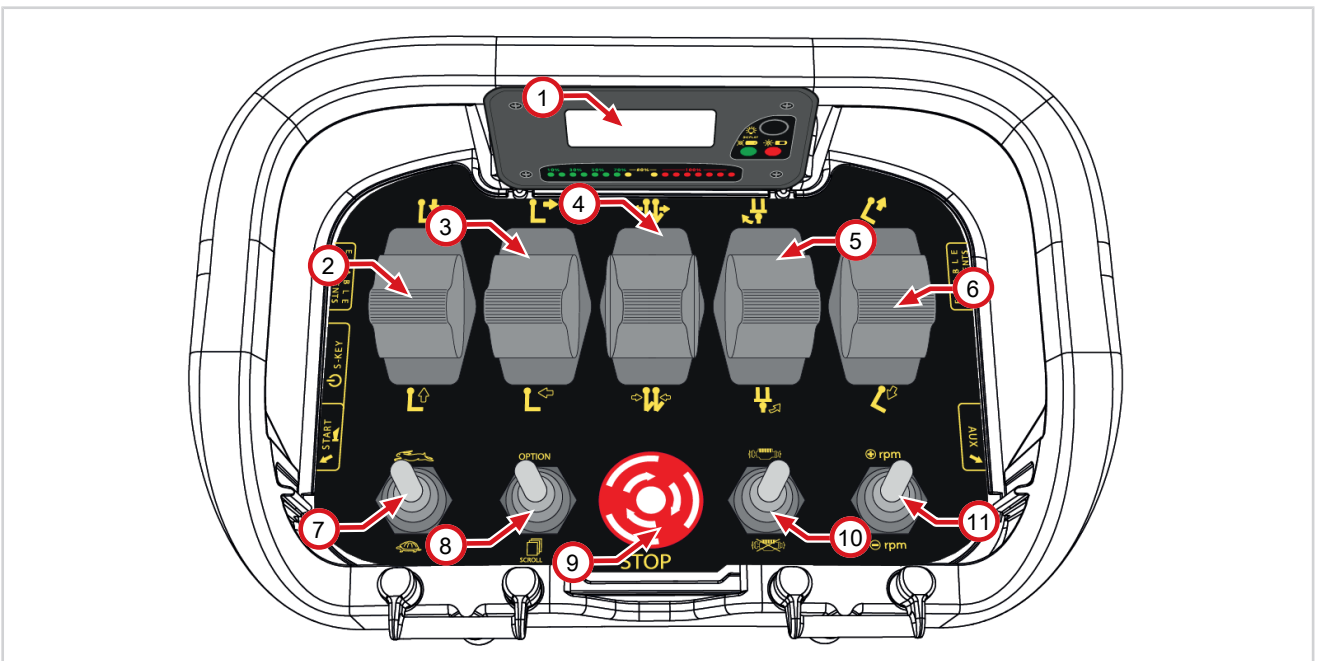

Fig. 160601-1

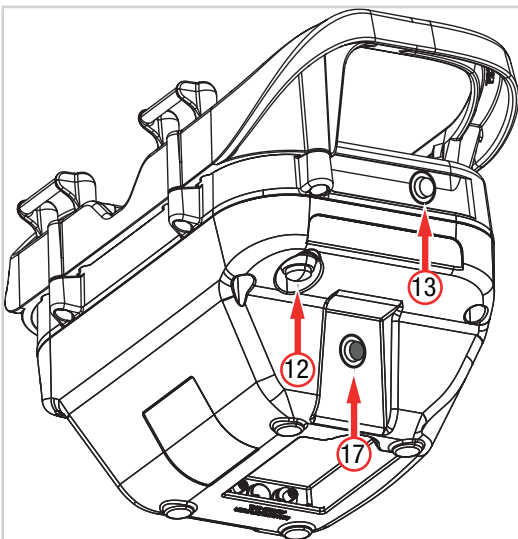

Fig. 160601-2

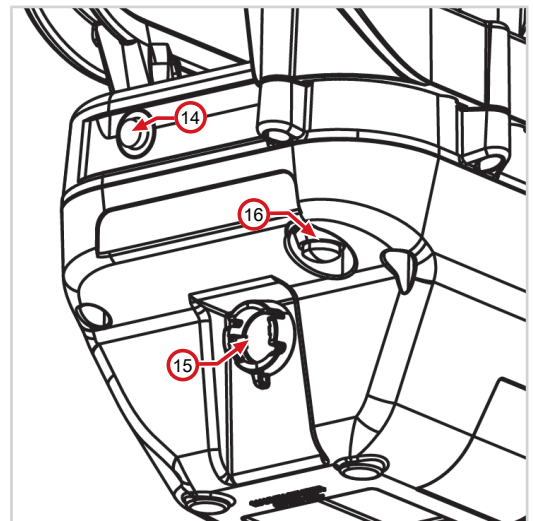
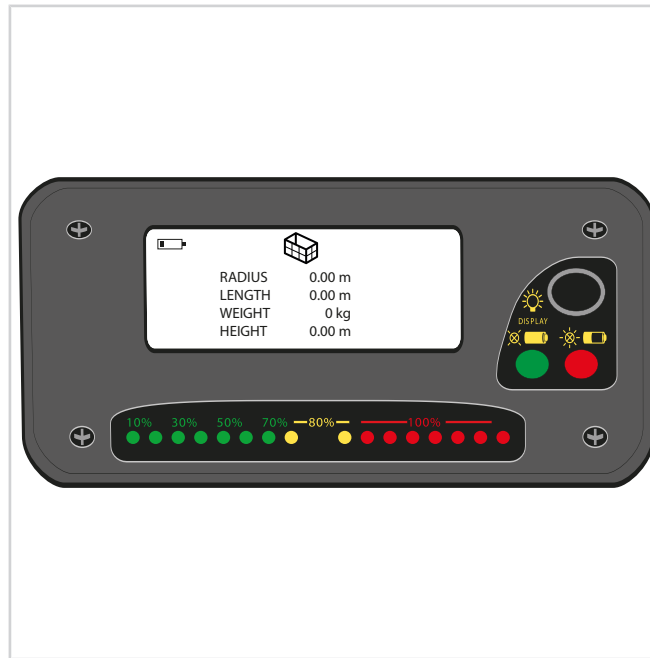

Fig. 160601-3

1	LCD display	9	Emergency stop button
2	Boom lowering / lifting lever	10	Vehicle ignition switch
3	Boom extension / retraction lever	11	Accelerator lever
4	Services lever	12	Electric contact on boom head button
5	Turret rotation lever (for rotating vehicles)	13	Deadman button
6	Up / down tilting lever	14	Deadman button
7	Movements speed lever	15	Remote control on/off key
8	Boom head solenoid valve lever	16	Remote control and horn enable button
17	Wired control connector		

Table 1: Remote control description

7.17.1.1 - Remote control display

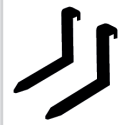

	Description
1	LCD display
2	Anti-tipping Led signal
3	Remote control status LED
4	Remote control battery status LED
5	Not used
WEIGHT	Current weight
RADIUS	Radius
HEIGHT	Load height from the ground
ANGLE	Boom angle
LENGTH	Boom extension length
	Forks operating mode icon









Description	
	Lifting accessory operating mode icon
	Basket operating mode icon
	Battery charge level
	Remote control signal level
	Fuel low level icon
	General alarm icon
	Chains error icon (present if the vehicle is prearranged with PLE)
	Levelness icon (present if the vehicle is prearranged with PLE)

Table 2: Display description and legend

7.17.1.2 - Remote control emergency stop button

The emergency stop button "9" (fig. 160601-1) turns off the diesel engine of the vehicle and the remote control, stopping all movements of the vehicle and of the equipment.

7.17.1.3 - Movements speed lever

The movements speed lever "7" (fig. 160601-1) allows to set the vehicle boom speed.



Move the lever up to set the fast movements (hare symbol)



Move the lever down to set the slow movements (turtle symbol)

Only slow movements are enabled when using the basket.

7.17.1.4 - Accelerator lever

The throttle lever "11" (fig. 160601-1) allows to maintain constant diesel engine revolutions of the vehicle.



Move the lever forward to increase the engine rpm of 200 rpm.



Move the lever backward to decrease the engine rpm of 200 rpm.

7.17.1.5 - Remote control on/off key

The on/off key "15" (fig. 160601-3) allows to turn on and turn off the remote control. To turn on the remote control, turn the knob from position O to position I.

7.17.1.6 - Remote control and horn enable button

The button "16" (fig. 160601-3) is used both to enable the remote control commands and to operate the horn of the vehicle.

7.17.1.7 - Deadman buttons

Buttons "13 and 14" (fig. 160601-2 and 160601-3) must be pressed to run boom functions (use any of these buttons).

7.17.1.8 - Boom control levers

The boom control levers are used to carry out various movements:

Boom lowering / lifting lever "2" (fig. 160601-1)



Boom down



Boom up

Boom extension / retraction lever "3" (fig. 160601-1)



Boom extension



Boom retraction

Services lever "4" (fig. 160601-1)



Services



Services

Turret rotation lever "5" (fig. 160601-1) [if present]



Turret counterclockwise rotation



Turret clockwise rotation

Tilting lever "6" (fig. 160601-1)



Tilting downwards



Upwards Tilting

7.17.1.9 - Electric contact on boom head button

The button "12" (fig. 160601-2) allows to activate the electrical contact on the boom head (if present). Press again the button to disable the electrical contact on the boom head.

7.17.1.10 - Boom head solenoid valve lever

The lever "8" (fig. 160601-1) allows to activate the solenoid valve on the boom head (if present).

7.17.1.11 - Wired control connection

The wired control cable is supplied to connect the receiver to the transmitter for working in environments where the remote control cannot be switched on or if the battery is dead.

Connect connector "A" to connector "17" on the remote control and to connector "B" on the vehicle.

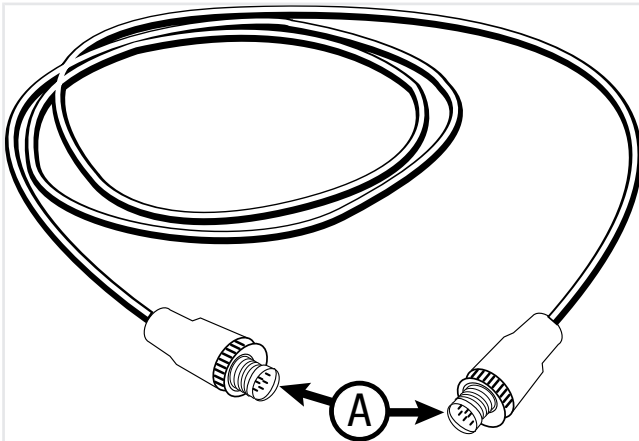

Figure: Wired control

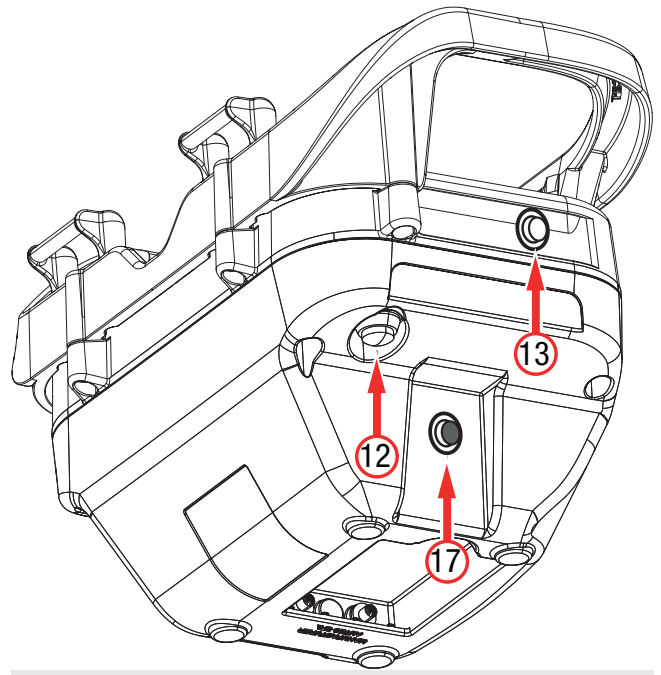

Figure: Wired control connection on the remote control

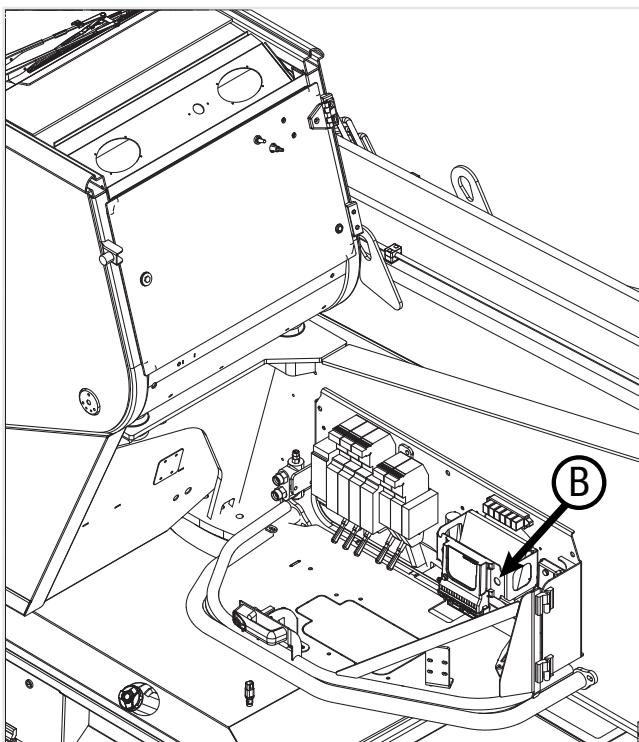

Figure: Wired control connection on the vehicle

7.17.2 - Remote control with joystick: Description

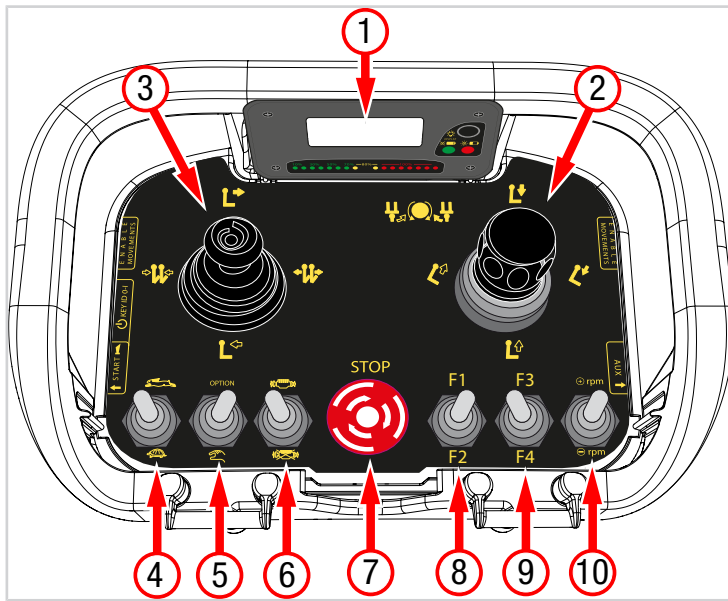

Fig. 160601- 4

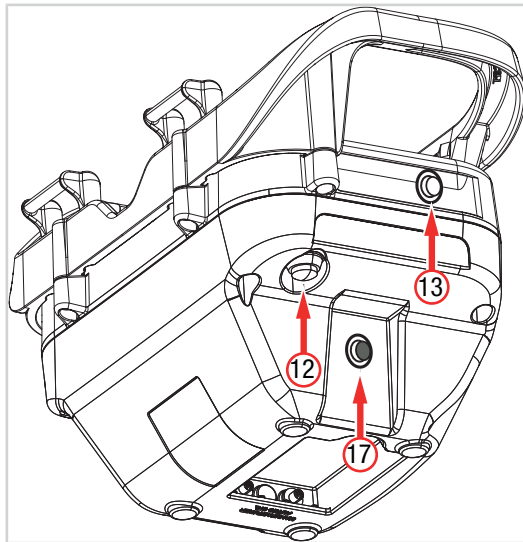

Fig. 160601- 5

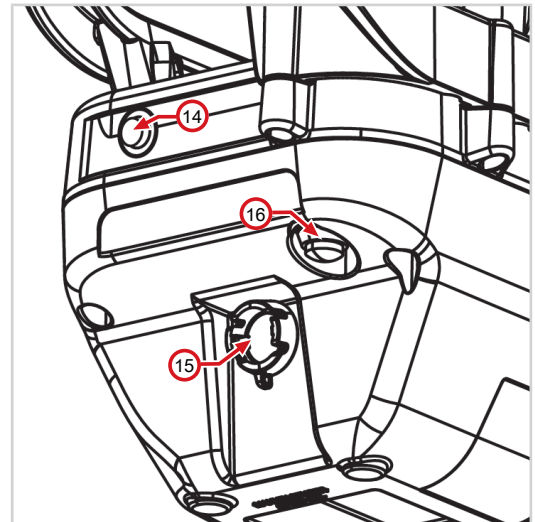
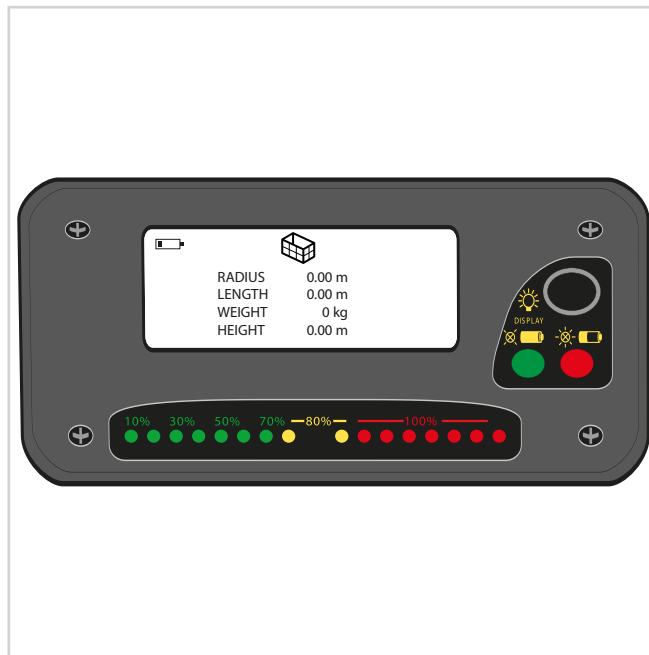





Fig. 160601- 6

1	LCD display	9	Vehicle equipment function lever (F3) (F4 NOT USED)
2	Joystick for boom lowering / lifting / down tilting / up tilting / services / turret rotation (for rotary machines)	10	Accelerator lever
3	Boom extension / retraction joystick /	12	Electric contact on boom head button
4	Movement speed lever (the hare function with basket equipment is disabled)	13	Deadman button
5	Boom head solenoid valve lever	14	Deadman button
6	Vehicle ignition switch	15	Remote control on/off key
7	Emergency stop button	16	Remote control and horn enable button
8	Vehicle equipment function lever (F1-F2)	17	Wired control connector

Table 3: Remote control description

7.17.2.1 - Remote control display



	Description
1	LCD display
2	Anti-tipping Led signal
3	Remote control status LED
4	Remote control battery status LED
5	Not used
WEIGHT	Current weight
RADIUS	Radius
HEIGHT	Load height from the ground
ANGLE	Boom angle
LENGTH	Boom extension length
	Forks operating mode icon
	Lifting accessory operating mode icon
	Basket operating mode icon
	Battery charge level





	Description
	Remote control signal level
	Fuel low level icon
	General alarm icon
	Chains error icon (present if the vehicle is prearranged with PLE)
	Levelness icon (present if the vehicle is prearranged with PLE)



Table 4: Display description and legend

7.17.2.2 - Remote control emergency stop button

The emergency stop button "7" (fig. 160601-4) turns off the diesel engine of the vehicle and the remote control, stopping all movements of the vehicle and of the equipment.

7.17.2.3 - Movements speed lever



The movements speed lever "7" (fig. 160601-1) allows to set the vehicle boom speed.

	Move the lever up to set the fast movements (hare symbol)
	Move the lever down to set the slow movements (turtle symbol)

Only slow movements are enabled when using the basket.

7.17.2.4 - Accelerator lever

The throttle lever "10" (fig. 160601-4) allows to maintain constant diesel engine revolutions of the vehicle.

	Move the lever forward to increase the engine rpm of 200 rpm.
	Move the lever backward to decrease the engine rpm of 200 rpm.

7.17.2.5 - Remote control on/off key

The on/off key "15" (fig. 160601-6) allows to turn on and turn off the remote control. To turn on the remote control, turn the knob from position O to position I.

7.17.2.6 - Remote control and horn enable button

The button "16" (fig. 160601-6) is used both to enable the remote control commands and to operate the horn of the vehicle.

7.17.2.7 - Deadman buttons

Buttons "13 and 14" (fig. 160601-2 and 160601-3) must be pressed to run boom functions (use any of these buttons).



7.17.2.8 - Boom control joystick "2"

The boom control joystick is used to carry out various movements:



Boom lowering / lifting joystick "2" (fig. 160601-4)

	Boom down
	Boom up

Turret rotation joystick "2" (fig. 160601-4) [if present]

	Turret anti-clockwise rotation
	Turret clockwise rotation



Tilting joystick "2" (fig. 160601-4)

	Tilting downwards
	Upwards Tilting

7.17.2.9 - Boom control joystick "3"

The boom control joystick is used to carry out various movements:

Boom extension / retraction lever "3" (fig. 160601-4)

	Boom extension
	Boom retraction

Service lever "3" (fig. 160601-4) used with F1-F2-F3 for Positive/Negative jib movements

	+ F1 Jib up movement + F2 Jib extension + F3 Jib anti-clockwise rotation
---	--



- + F1 Jib down movement
- +F2 Jib retraction
- +F3 Jib clockwise rotation

7.17.2.10 - Electric contact on boom head button

The button "12" (fig. 160601-5) allows to activate the electrical contact on the boom head (if present). Press again the button to disable the electrical contact on the boom head.

7.17.2.11 - Boom head solenoid valve lever

The lever "5" (fig. 160601-4) allows to activate the solenoid valve on the boom head (if present).



Confirm fastened
equipment



NOTE

With the baskets correctly installed it is not necessary to press ok.

7.17.2.12 - Vehicle equipment function levers

Levers "8" and "9" (fig. 160601-4) have the same function of the F1 - F2 - F3 buttons on the left-hand joystick in the cab.

7.17.2.13 - Wired control connection

The wired control cable is supplied to connect the receiver to the transmitter for working in environments where the remote control cannot be switched on or if the battery is dead.

Connect connector "A" to connector "17" on the remote control and to connector "B" on the vehicle.

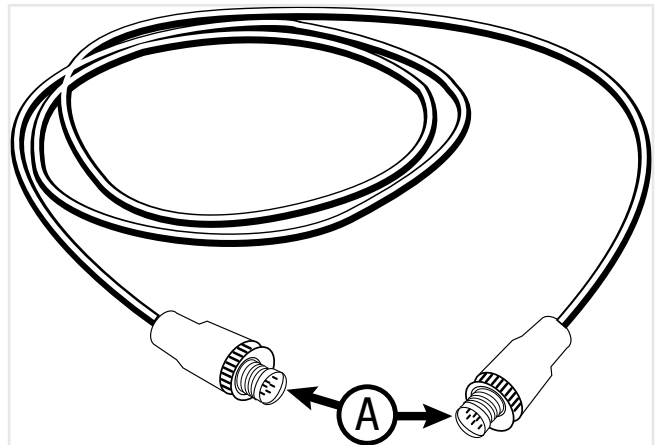

Figure: Wired control

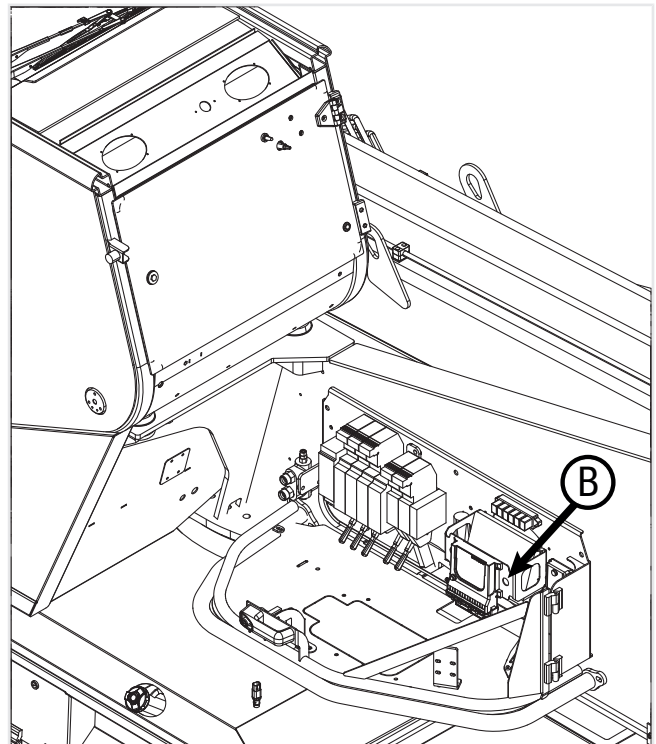

Figure: Wired control connection on the vehicle

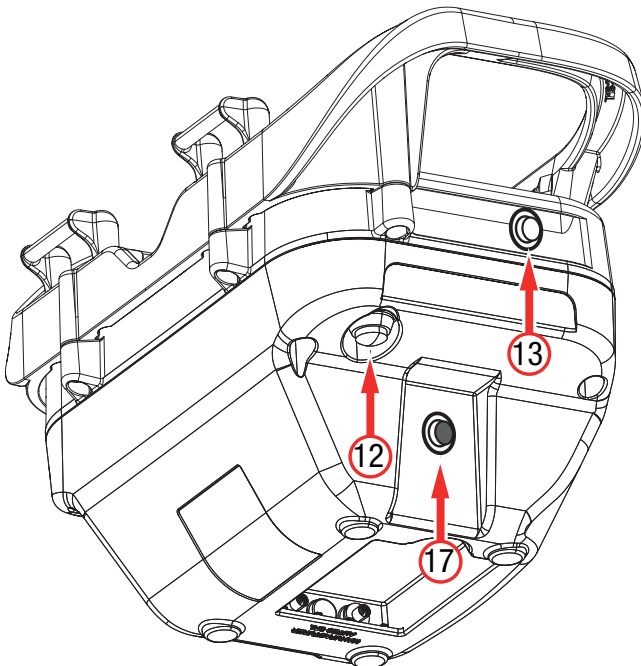

Figure: Wired control connection on the remote control

7.17.3 - Remote Control: Use

The vehicle, if prepared, can be used by the remote control.

The movements that can be performed from the remote control are:

- Telescopic boom extension/retraction.
- Telescopic boom Up/Down movement.
- Tilting.
- Services.

To use the vehicle by remote control carry out the following operations:

Operations on the vehicle:

Assemble the equipment on the vehicle, if not already installed. (Refer to the chapter "Equipment installation" and set the correct mode of use of the vehicle)

- Lay the load on the ground.
- Level the vehicle (if available).
- Place the vehicle on outriggers (if installed).
- Place the gear lever to neutral "N" position.
- Engage the parking brake.
- Press the switch "1" (fig. 150912-1) to enable the controls from the remote control. Pressing the switch will automatically shut down the vehicle engine.

Turn the vehicle ignition key in position "I" without starting the engine.

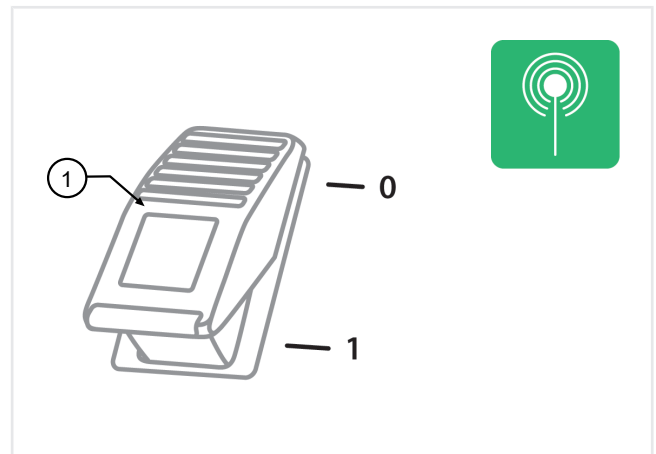

Figure: 150912-1

Operations on the remote control:

- Turn the remote control on/off knob "15" (fig. 150912-2) to position "1".
- Press the remote control on/off button "16" to enable the remote control.
- Move the vehicle on/off lever "10" (fig. 150912-3) up and hold it for 2 seconds.

The ON remote control indicator light will flash green until the remote control will remain on.

When switching on the remote control, it will emit an alert tone.

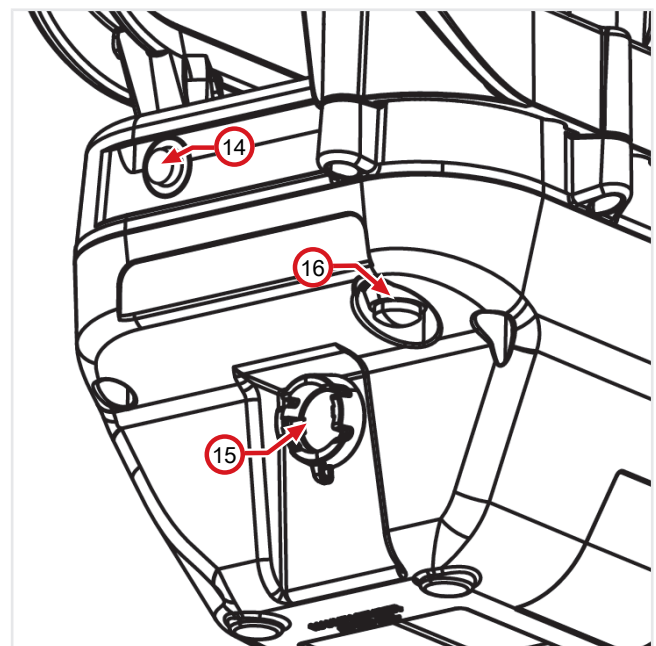

Figure: 150912-2

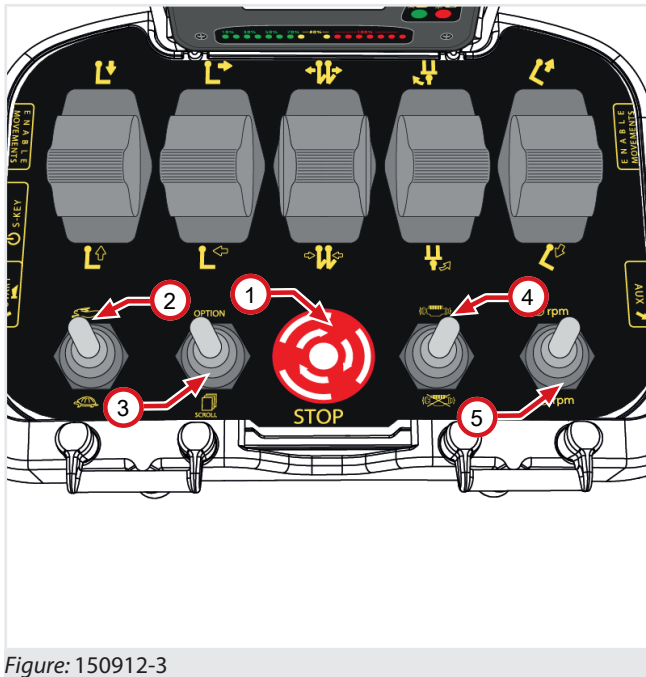

Figure: 150912-3



WARNING

Always remain at a safe distance from the vehicle and from the load, outside the area that would be occupied in case of vehicle overturning and load fall.

When using the vehicle with remote control:

- The emergency button in the cab is always active.
- The gear of the vehicle is inhibited.



NOTE

After 4 min of non-use of the remote control, the remote control and the vehicle will turn off.



ATTENTION

When using the vehicle with remote control, the buzzer and the red LED on the vehicle come into operation when the vehicle reaches the tipping limit.

To reset the vehicle in safe conditions, make movements that do not aggravate the stability depending on the type of equipment currently used.

7.17.4 - Remote Control: Turn off the vehicle and the remote control

To turn off the machine engine and the remote control, turn the ignition knob from position "1" to position "0".

7.17.5 - Remote Control: Receiver

The remote control receiver is installed on the rear of the vehicle. When the remote control is selected in the cab, the receiver turns on. For the operating specifications carefully read and learn the use and maintenance instructions of the remote control manufacturer.

7.17.6 - Remote Control: Recharge

At the seat side there is the remote control battery charger.

7.17.7 - Remote Control: Back-up

If the transmitter unit can not be used, it can be replaced by a Transmitting Unit called "BACK-UP UNIT", to be requested to Autec.

It is identical to the Unit that can no longer be used and is distinguished only by the presence of the word "BACK-UP UNIT" in the battery housing.



ATTENTION

Insert the "Key ID 0-1" or the "ID internal tx memory" of the transmitting unit that is no longer usable in the "BACK-UP UNIT" and perform the procedure for storing the address described below.

Storing the address

With the battery charged and the ignition key inserted in the "BACK-UP UNIT", carry out the following procedure:

- press the STOP button,
- Press the START button and keep it pressed until the green LED turns off,
- disengage the STOP button.

Now it is possible to start the Remote control and command the vehicle with the "BACK-UP UNIT" transmitting unit.

7.17.8 - Remote Control: Additional information



NOTE

For additional information on the use and maintenance of the remote control, refer to the specific manual of the remote control.

7.18 - Engine

7.18.1 - AdBlue®

AdBlue® is a registered trademark of Verband der Automobilindustrie (VDA).

AdBlue is used in the selective catalytic reduction (SCR) to reduce emissions of nitrogen oxides from the exhaust gases produced by vehicles equipped with a diesel engine.

The solution is non-toxic, non-flammable and is not dangerous to handle. However, the solution can be corrosive to some metals and must be stored and transported using the proper materials.



NOTE

Refer to the instructions on the packaging regarding transportation, handling or storage.

7.18.1.1 - AdBlue®: The risks of an AdBlue out of specification

The SCR systems are very sensitive to the quality of AdBlue used.

It is extremely important that the AdBlue complies with the specifications and has not been contaminated during transport, handling or storage.

A key aspect to consider is that the damage that can result from an AdBlue containing calcium or metals out of specification are not immediately visible, but appear after a certain time, and even after many kilometers.

In summary the problems that can arise from a low quality AdBlue are of two types: aging and poisoning of the catalyst

- Aging is typically given by the presence of substances that causes the catalyst to loose its efficiency and reduce its life and ability to operate (reducing the usable area). The catalyst is designed to last the lifetime of the vehicle while if AdBlue with parameters (e.g. Calcium) out of specification is used, it will last less and must be replaced with high costs.
- Poisoning is typically due to the presence of metals (e.g. Zinc or copper) or pollutants (which should never be present in the AdBlue) as it immediately ruins the catalyst and makes it unusable. The result is an immediate need to replace the catalyst in order to enable the SCR system operation again.

Therefore aging takes place slowly and stops the vehicle after a long time while poisoning is rather immediate and immediately stops the vehicle. Both,

however, require costly catalyst replacement and can be prevented only using high quality AdBlue without contaminants.

7.18.1.2 - AdBlue®: Specifications

Specifications of AUS32 (AdBlue®) Complying with DIN 70070

Urea 32.5 % - solution in water			
Characteristics	Min	Max	Reference unit
Urea content	31.8	33.2	% of weight
Density at 20°C	1.0870	1.0930	g/cm ³
Refractive index at 20°C	1.3814	1.3843	
Alkalinity as NH3	-	0.2	%
Biuret	-	0.3	%
Aldehyde	-	5	mg/kg
Insoluble	-	20	mg/kg
Phosphates (PO4)	-	0.5	mg/kg
Calcium	-	0.5	mg/kg
Iron	-	0.5	mg/kg
Copper	-	0.2	mg/kg
Zinc	-	0.2	mg/kg
Chromium	-	0.2	mg/kg
Nickel	-	0.2	mg/kg
Aluminum	-	0.5	mg/kg
Magnesium	-	0.5	mg/kg
Sodium	-	0.5	mg/kg
Potassium	-	0.5	mg/kg

7.18.1.3 - AdBlue® tank filling



WARNING

Danger of burns caused by boiling hot AdBlue®

In the following situations, the AdBlue® pipes are under pressure:

- With engine running
- After turning off the engine

Opening the fueling system, the leakage of boiling hot AdBlue®/DEF may cause burns.

- Cool the engine before opening the fueling system.

- Always wear protective gloves, clothing, and goggles to open the system.
- Slowly open the pipe fittings and the clamping elements of the system components.



WARNING

Damage to the engine caused by the presence of AdBlue® in the fuel

The AdBlue® must not be refilled into the fuel tank. Fill AdBlue® exclusively in the AdBlue® tank.

Avoid excessive filling of the AdBlue® tank.



WARNING

When opening the AdBlue® tank, small amounts of ammonia vapor may escape.

Fill the AdBlue® tank only in well-ventilated environments.

Avoid AdBlue® contact with skin, eyes or clothing.

Keep children away from the AdBlue®

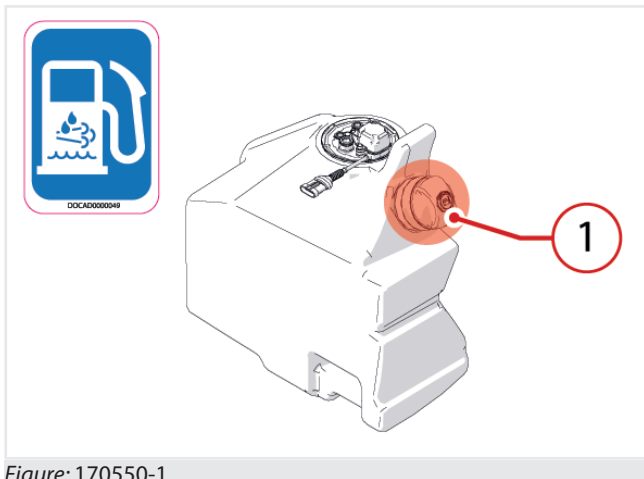

Figure: 170550-1

To top up the AdBlue level (fig. 170550-1) it is necessary to:

- Park the vehicle and turn off the engine.
- Allow the engine to cool down.
- Open the Ad-Blue tank cap "1".
- Fill up.
- Close the Ad-Blue tank cap.



Figure: 170550-2

7.18.1.4 - After run

The After run indicator is lit until the Urea circuit is operating and stays on until **90 seconds** after the machine engine was turned off.



In this period of time an electric pump will drain the urea circuit

7.18.1.5 - DPF regeneration



WARNING

DO NOT turn the engine off during the regeneration phase.

7.18.1.6 - AdBlue error list



NOTE

In case the vehicle is in error, contact a *Dieci* service center to solve the problem, indicating the error code reported.

For more information about the errors display, refer to the "Central instrument panel" chapter.

7.18.2 - FPT Series N Stage V engine



NOTE

The use and maintenance manual of the engine is an integral part of the documentation supplied with the vehicle.

Consult the engine manual or contact an authorized workshop for maintenance.

We recommend that you carefully read the information contained in the instruction manual and comply with them: in this it is possible to avoid accidents, enjoy the manufacturer's warranty and always have an engine in peak operating condition.

7.18.2.1 - Validation procedure



Figure: fig. 160801-1



Figure: fig. 160801-2



Figure: fig. 160801-3

If the engine shows an error to the exhaust gas treatment system, the validation procedure is started.



ATTENTION

Do not use the vehicle if the validation procedure screen is shown.

Contact the authorised service to resolve the problem.

The validation procedure includes 3 levels, in which the system carries out checks on the engine and on the exhaust gas treatment system to check its correct operation.

Each level of the validation procedure requires a time of 30 minutes, in which the system carries out the necessary checks. If the checks are successful, the validation procedure is terminated and the display will return to the HOME page display. Otherwise, the validation procedure will pass to the next level and the 30-minute countdown starts again.

7.18.2.2 - AdBlue® filter maintenance



NOTE

This operation requires the intervention by a trained maintainer.

Refer to DIECI Technical Support Service.

The AdBlue® filter is located inside the pump of the urea system, under the cover "1" (fig. 170110-1).

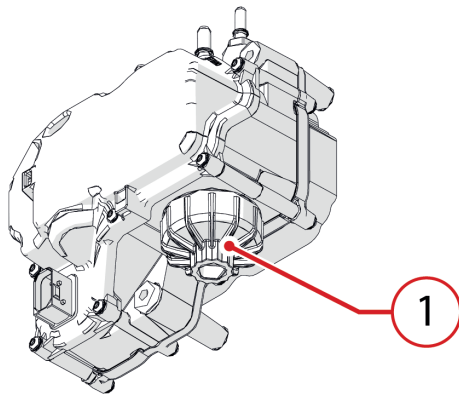

Figure: fig. 170110-1

7.18.2.3 - FPT Series N Stage V engine errors list



NOTE

In case the vehicle is in error, contact a *Dieci* service centre to solve the problem, indicating the error code reported.

For more information about the errors display, refer to the "Central instrument panel" chapter.

The ATS (After treatment System) consists of 3 different processes that can lead to an increase in the minimum rpm (Low Idle Up).



- **HC Accumulation**

To reduce the hydrocarbon accumulation, the engine control unit applies an increase in the Low Idle value from 850 rpm to 1,300 rpm; this strategy depends on receiving the Safe State signal from the vehicle control unit.

When the operator:

- Holds the joystick to perform boom movements;
- Removes the parking brake;
- Moves the vehicle.

The Low Idle value returns to its default value (850 rpm) and then increases again when the Safe State signal is received.

- **DPF Automatic Regeneration**

To reduce the particulate accumulation in the DPF, the engine control unit applies an increase in the Low Idle value from 850 rpm to 1,300 rpm; this strategy does not depend on receiving the Safe State signal from the vehicle control unit.

- **DPF Manual Regeneration**

To reduce the particulate accumulation in the DPF, if the automatic regeneration was not enough (DPF = 2 shown on the display), the operator can request a manual regeneration by using the corresponding button. This strategy depends on receiving the Safe State signal from the vehicle control unit. Therefore, when the operator:

- Holds the joystick to perform boom movements;
- Removes the parking brake;
- Moves the vehicle;

regeneration stops (**situation to be avoided until regeneration has been completed!**)



NOTE

During this operation it is strongly recommended not to leave the vehicle unattended



NOTE

The following chapters refer to vehicles for the agricultural sector.

The optional equipment for the agricultural sector are marked with the symbol (**).

9.1 - Agricultural applications



WARNING

The vehicle is not provided with a protective structure against harmful dust, aerosols and vapors. Adopt appropriate personal protective equipment even when using the vehicle in the cabin.

Refer to the packaging of the product used to use the appropriate protective equipment.



ATTENTION

The vehicle described in this manual is not designed for use with sprayers for noxious or hazardous substances; it is prohibited to use the vehicle for this purpose without adopting the proper protective equipment for the operator.



DANGER



Inhalation danger for operators and bystanders. For protection against harmful dust, aerosols and vapors, refer to the instructions provided by the manufacturer of chemicals, by the manufacturer of the sprayer and to the basic rules contained in this manual.

9.2 - Forest and forestry applications



WARNING

The vehicle is not provided with a protective structure against penetration of objects (OPS).

There are no optional attachments for its use in forestry applications.



DANGER

The main risks if the vehicle is used in forestry applications are falling trees on the cab and the penetration of objects in the space reserved to the operator.

The vehicle described in this manual is not designed for heavy-duty forestry use; it is forbidden to use it for this purpose.

9.3 - Caisson descent *



NOTE

The Caisson descent is an optional attachment for the agricultural sector, available only on vehicles with open center distributor.

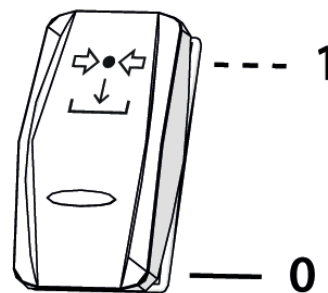

Figure: 150309-1

The Caisson Descent allows to use equipment or trailers with single-acting cylinders, if connected to the rear **YELLOW** hydraulic socket.

To put the socket under pressure it is necessary to:

- Select the rear **GREEN** coupler with the selector hydraulic coupler selector.
- Use the services control to lift the caisson.
- After reaching the desired height release the control. The trailer will remain stationary in that position.

To relieve pressure from the socket it is necessary to:

- Press the Caisson descent button (fig. 150309-1) and hold down until needed.

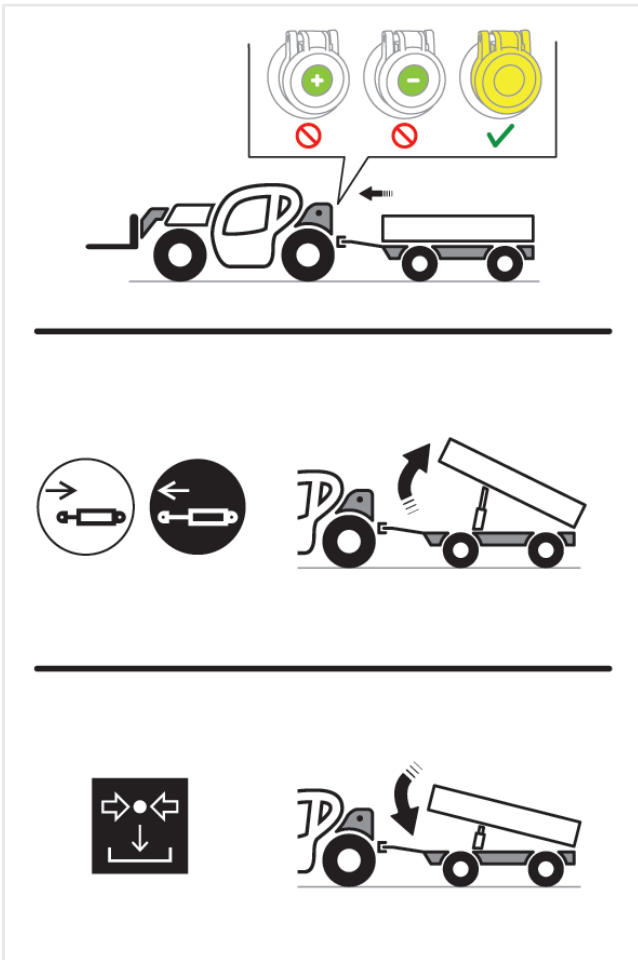

Figure: 150309-2



DANGER

When using the Caisson Descent, make sure that nobody is in range of the vehicle and if the trailer is connected to it. Danger of crushing.



ATTENTION

When using the Caisson Descent (YELLOW rear hydraulic socket), it is not allowed to use the GREEN rear hydraulic socket.

9.4 - Trailer descent **



NOTE

The Trailer descent is an optional attachment for the agricultural sector, available only on vehicles with closed centre distributor.

The Trailer Descent allows to use trailers or equipment with single-acting cylinders, with any hydraulic socket on the vehicle.

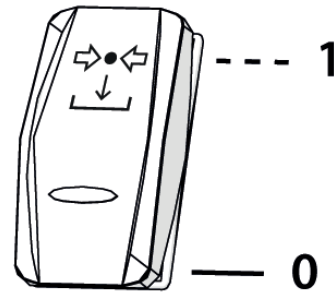

Figure: fig. 150308-1

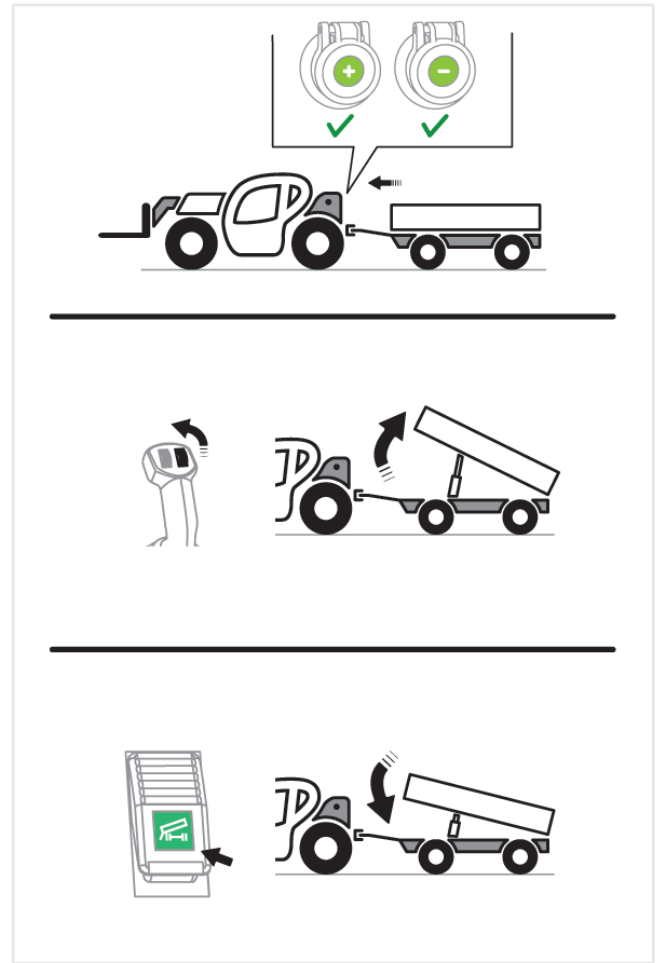

Figure: 150308-2

To put the socket under pressure it is necessary to:

- With the hydraulic sockets switch, select the rear socket on which the equipment or the trailer is installed.
- Use the services control to lift the caisson.
- After reaching the desired height release the control. The trailer will remain stationary in that position.

To relieve pressure from the socket it is necessary to:

- With the hydraulic sockets switch, select the rear socket on which the equipment or the trailer is installed.

- Press the Trailer Descent button (fig. 150308-1) and hold down until needed.



DANGER

Danger of crushing.

When using the Trailer Descent, make sure that nobody is in range of the vehicle and if the trailer is connected to it.

9.5 - Towing a trailer **



NOTE

The Trailer towing is an optional accessory for the agricultural sector.

9.5.1 - Warnings for towing a trailer



WARNING

Driving on roads with trailer is permitted only to vehicles approved as "Agricultural Tractors", subject to the exceptions permitted by the Highway Code in force in the country of use of the vehicle.



WARNING

Carefully follow the instructions contained in the user manuals of the mounted or towed vehicles or of the trailer.

It is forbidden to use the vehicle or the equipment and trailers installed unless all instructions have been followed.



ATTENTION

Use the correct point on the tractor to connect equipment. Use the tow hitches for trailers and the 3-point elevator for mounted or semi-mounted equipment. Do not use the 3-point elevator as a towbar.



WARNING

The vehicle steers more sharply than the object being towed.

During transport, pay attention when driving through bends.



WARNING

Leaving too abruptly causes high risk of tipping.

Follow all precautions listed below before towing equipment or a trailer with the vehicle.

- Check the correct operation of the braking system and signaling system of the vehicle and of the trailer.
- Check that the trailer complies with all relevant regulations in the country of use.
- Make sure that the safety cotter pin is correctly inserted inside the pin used on the tow hitch.
- The tow hitch must be selected based on the type of trailer or equipment to be towed in compliance with the indications of the vehicle registration document and on the label in the cab, or in accordance with the safety standards in force in the country of use.
- The maneuverability and safety of the vehicle depends on the correct adjustment of the tow hitch. Avoid towing trailers too heavy loads or trailers.
- After startup, slowly release the clutch to avoid jerky movements of the trailer or of the tool.
- During the movement of the trailer (uphill, downhill, travel) check that no one is near it. Danger of crushing.



DANGER

With disconnected trailer take the necessary precautions to prevent it from moving in an uncontrolled manner.

Do not remain in the area between the tractor and the towed vehicle.

9.5.2 - Towing a trailer on the road for AGRICULTURAL vehicles

It is permitted to tow a trailer on public roads with the vehicle only if all the following conditions are present:

- The vehicle is approved as an agricultural vehicle.
- The vehicle has an approved tow hitch.
- The vehicle has the label (Fig. 1-J0500) showing all the data on the hitch installed and the maximum towable weight.
- The rules regarding trailers towing on public roads, in force in the country of use of the vehicle, are observed.

9.5.3 - Towing a trailer on the road for CONSTRUCTION vehicles

It is not allowed to vehicles approved as construction vehicles to tow trailers on public roads, except for the cases permitted by the Highway Code in force in the country of use of the vehicle.

9.6 - Trailer braking

9.6.1 - Trailer braking system



NOTE

The trailer braking system is an optional accessory.

The trailer braking system is necessary to tow a trailer with a total mass greater than 3000 kg.

For towing trailers on public roads, refer to the plate in the cab (fig. 020819) and to the vehicle registration document.

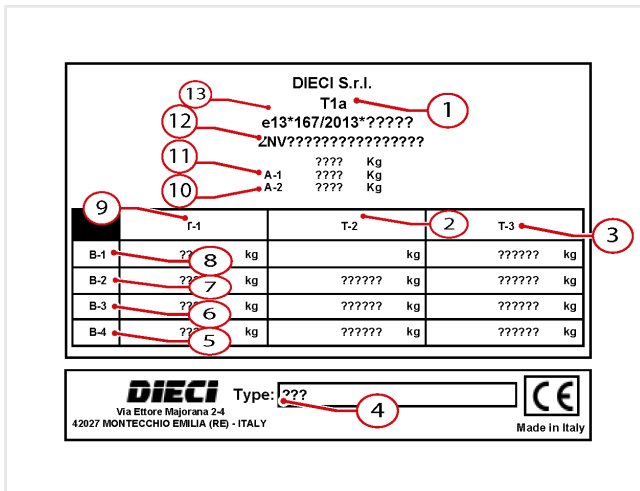

Figure: Fig. 020819

After connecting the trailer to the tow hitch of the vehicle, connect the braking system and the electrical system of the trailer to the vehicle through the special sockets (fig. 310719-2)

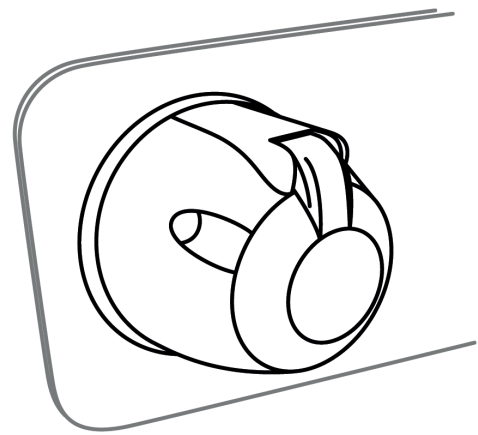

Figure: fig. 310719-2

When the vehicle is equipped with a trailer braking system, the "Trailer parking brake check" button (fig. 310719) and the braked trailer warning light (fig. 310719-1) are located in the cab.

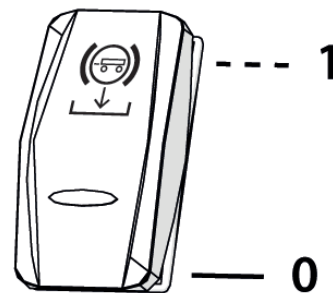

Figure: Fig. 310719

The braked trailer warning light (fig. 310719-1) comes on when the vehicle and trailer are braked with the parking brake. When the parking brake of the vehicle is released, the braked trailer warning light should go off.



Figure: fig. 310719-1

9.6.1.1 - Trailer parking braking check

The trailer braking check button (Fig. 310719) allows to temporarily release the brake of the trailer connected.

When the button (fig. 310719) is in position "1" the warning light (fig. 150208-1) must be off.

This function is used to check if the vehicle is able to keep the trailer stationary even on a slope; in order to avoid that during the trailer disconnection operations it will drag or push the vehicle to which it is connected.



DANGER

By activating the parking brake on the vehicle, the trailer connected to the vehicle is braked. Pressing the button "2" (fig. 180445-1) when the trailer braking circuit is connected to the vehicle, the trailer will be not braked; while the vehicle will continue to be braked thanks to the negative parking brake.

Pay utmost attention in the case of sloping ground. Place chocks under the trailer wheels to prevent accidental movement.



DANGER

Danger of crushing and damage to the vehicle.

Park the vehicle with trailer on a flat surface. If you need to park the vehicle with trailer on a slope, take appropriate precautions (wedges or auxiliary brakes) before carrying out trailer disconnection.

There are two types of trailer braking systems:

- Pneumatic trailer braking
- Hydraulic trailer braking

9.6.1.2 - Pneumatic trailer braking

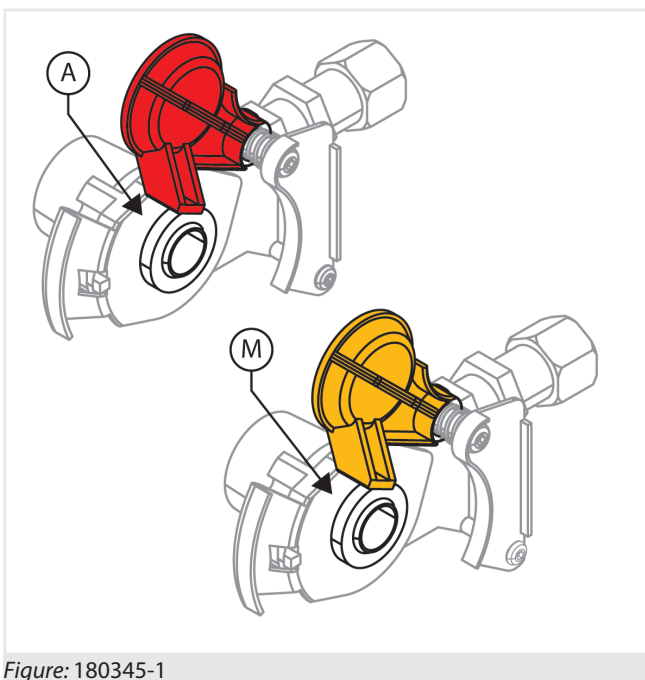

Figure: 180345-1

The pneumatic braking of EEC type includes two couplings:

Condition	Yellow (M)	Red (A)
Vehicle in motion with parking brake disengaged	No air	Yes air
Vehicle in motion with parking brake engaged	No air	No air
Vehicle in motion with parking brake disengaged and brake pedal pressed	Yes air	Yes air

The warning light (fig. 150208-1) comes on when the trailer is braked with the parking brake

The pressure gauge (fig. 150208-2) on the central instrument panel indicates the pressure of the trailer braking system.

The maximum pressure of the pneumatic system is **0.72 MPa** (104.4 psi).



150208-1



150208-2



DANGER

Do not move the vehicle until the warning light goes off because the trailer might not brake regularly.

Attach the trailer to the tow hitch of the vehicle, and then make the connections of the braking system of the trailer.

Adjust the braking control distributor (fig. 150208-3) depending on the type of trailer and load transported. The braking control distributor is located under the cab on the right side.

- Unscrew the locking dowl "1"
- Turn the ring nut to the "B" sign to anticipate the trailer braking.
- Turn the ring nut to the "A" sign to delay the trailer braking.

Fig.

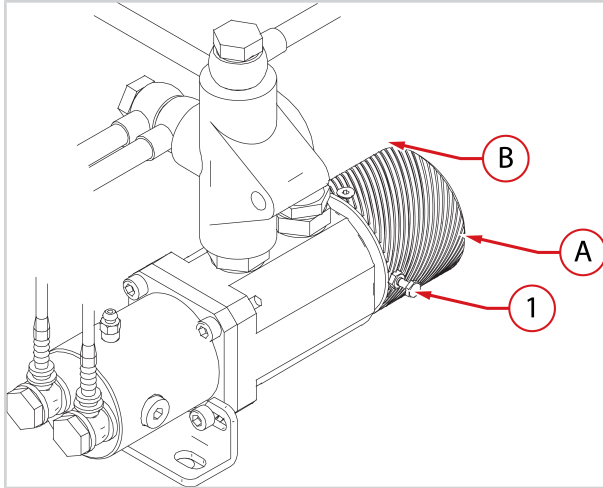

Fig. 150208-3

9.6.1.3 - Pneumatic braking type CUNA NC 144-04

(only for the Italian market)

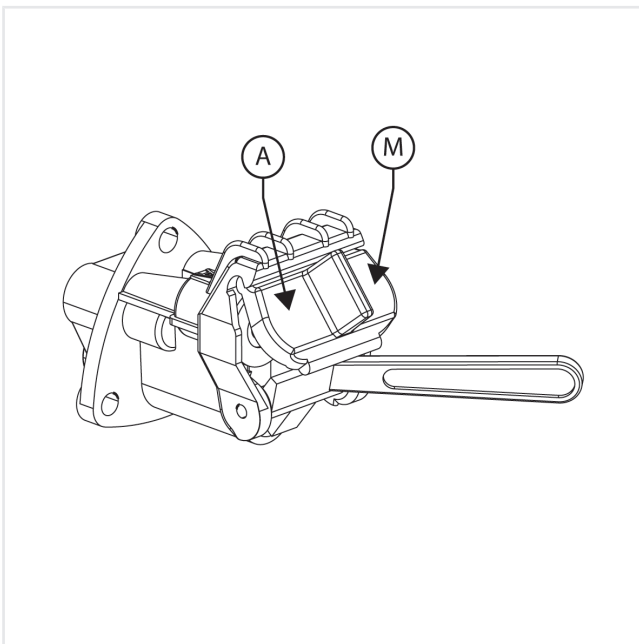

Figure: 180346-1

The pneumatic braking type CUNA has a single aluminium coupling:

Condition	Yellow (M)	Red (A)
Vehicle in motion with parking brake disengaged	No air	Yes air
Vehicle in motion with parking brake engaged	No air	No air
Vehicle in motion with parking brake disengaged and brake pedal pressed	Yes air	Yes air

9.6.2 - Hydraulic braking MR type

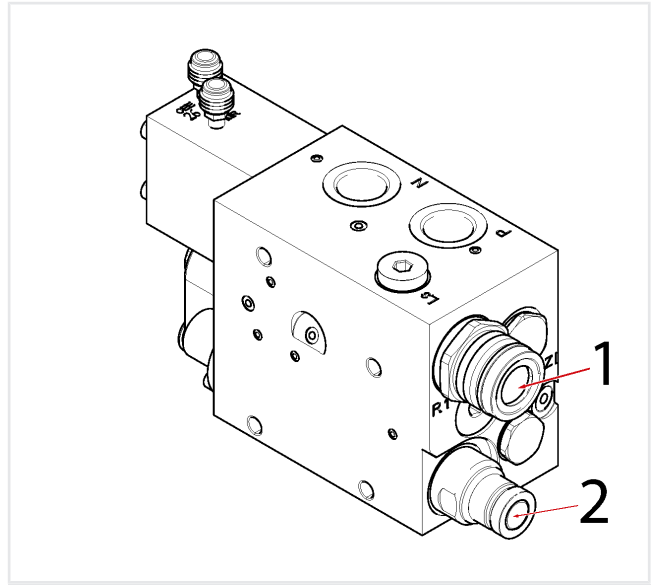

Figure: figure 160201-1

The trailer braking system acts proportionally to the pressure exerted on the brake pedal of the vehicle.

To connect the hydraulic braking system of the trailer to the vehicle system it is necessary (fig. 160201-1):

- Do the approaching operations to the trailer and connect it to the appropriate hitch for the vehicle trailers.
- Turn off the vehicle.
- Connect the braking circuit of the trailer to the hydraulic socket "1" and "2".
- Turn on the vehicle.

If the socket "2" is not used, it must be adequately protected with its cap.

To disconnect the hydraulic braking system of the trailer from the vehicle (fig. 160201-1):

- Place the vehicle and the trailer on level and non slope ground.



WARNING

Place the vehicle and the trailer on a non slope ground

If it is not possible to place the vehicle and the trailer on non slope ground, place wedges under the wheels of the trailer and engage the negative brake of the vehicle to prevent it from moving during the operation.

-
- Disconnect the tubes from the couplings "1" and "2".

- Continue the trailer release operations.

If the sockets "1" and "2" are not used they must be suitably protected by means of the appropriate caps.



NOTE

If the trailer has only one connection pipe, connect the pipe to the coupling "1" (EEC type trailer braking)

9.6.3 - Hydraulic braking type CUNA NC 344-05

(only for the Italian market)

The trailer braking operates under pressure; the hydraulic circuit of the vehicle provides a constant pressure to the trailer braking system.

By connecting the braking system of the trailer to the vehicle, the trailer is released from the parking brakes and can move.

The pressure is varied in proportion to the pressure exerted on the brake pedal of the vehicle.

The trailer brake valve (fig. 150212-1), located on the back of the vehicle, has a lever for the hydraulic braking activation and deactivation:

- When the lever is in "0" position the hydraulic braking is activated.
- When the lever is in "1" position the hydraulic braking is deactivated.

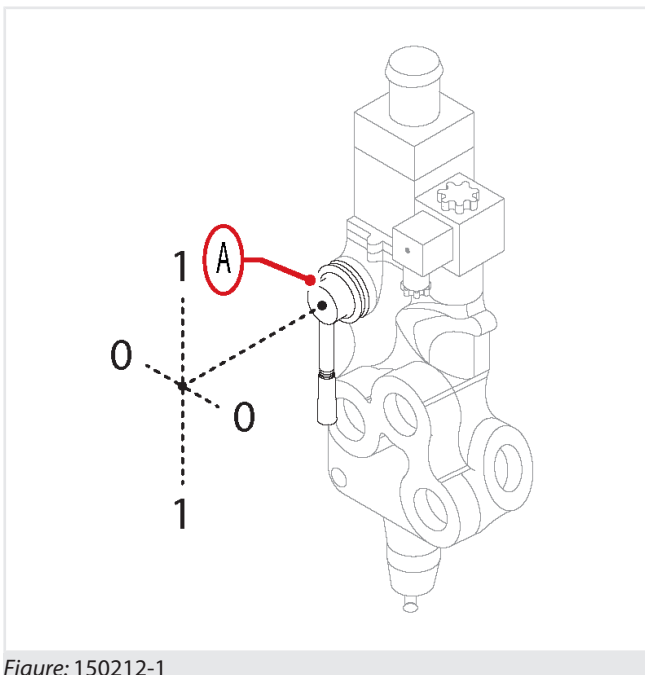

Figure: 150212-1



WARNING

With the trailer connected and lever "A" in position "0", the parking brake is enabled on the trailer.

In case of non-use of the trailer it is advisable to move the lever in the "1" position to prevent that the systems remains under pressure. Keeping the system under pressure entails an unnecessary loss of engine power, with consequent higher power consumption, and unnecessary heating of the hydraulic oil.

9.7 - Trailers electrical socket **



NOTE

* The trailer electrical socket is an optional accessory.

The trailer electrical socket (fig. 150220-1) allows to connect the lighting system of the trailer to the vehicle.

Connect the trailer to the vehicle through the Hitch for trailers before making the electrical connections.

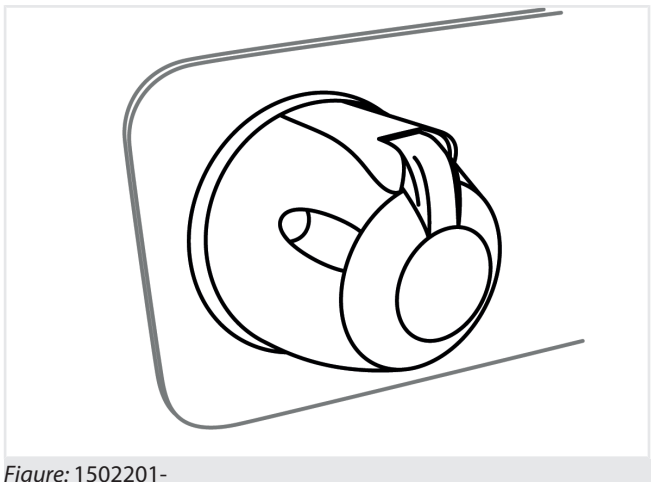

Figure: 1502201-

9.8 - Hitches for rear trailers **



NOTE

All different types of trailer hitches are optional accessories for the agricultural sector.

The trailer hitches are located in the rear part of the vehicle and may have different capacities depending on the customer's request.

The towing capacity is limited for each vehicle in accordance with the authorized weight to be towed, the traction force and the vertical load of the tow pin. These data are shown on the vehicle registration document.

Before moving the vehicle with the trailer ensure the correct positioning of the locking pin.

The pin of the rear hitch "1" (fig. 150213-1) is correctly positioned and locked when this passes through both sides of the hook "2" and is locked by its cotter pin "3".

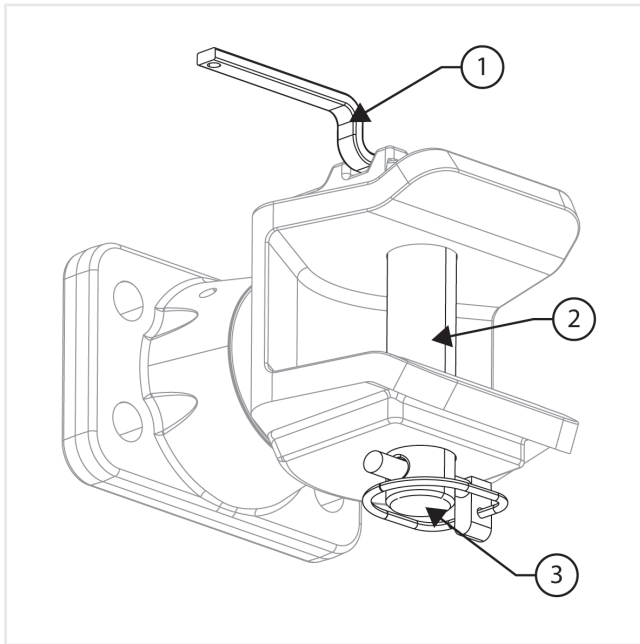
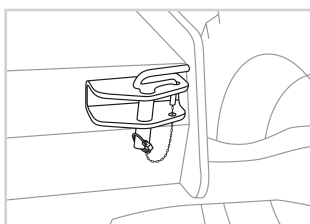

Figure: 150213-1



NOTE

Refer to the "Technical data" chapter to know the characteristics of the towing hook installed.



150213-2

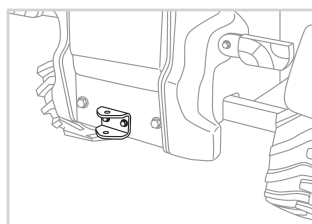

150213-3



DANGER

On the vehicle there are sheet metal hooks (fig. 150213-2 and fig. 150213-3) to facilitate the vehicle towing operations in case of emergency or breakdown.

It is forbidden to use these hitches for towing trailers, danger of damage to the vehicle and to the trailer as these hitches have capacity and resistance inadequate for this purpose.

9.9 - Height adjustable tow hitch adjustment **



NOTE

The Height adjustable tow hitch is an optional accessory for the agricultural sector.

The height adjustable tow hitch (fig. 150502-1) allows the operator to adapt the tow hitch according to the type or characteristics of the trailer towed.

To adjust the tow hitch height:

1. Hold the pin "1" and pull outward.
2. Keep the pin "1" pulled and lift the handle with safety lock "2"; in these conditions the hook is free to move in its guides.
3. Release the pin "1".
4. Lower or lift the hook "3" accompanying it by the handle "2".
5. After reaching the desired position, release the pin "1".
6. Lower the safety handle "2" until the hook "3" locks in the desired position.

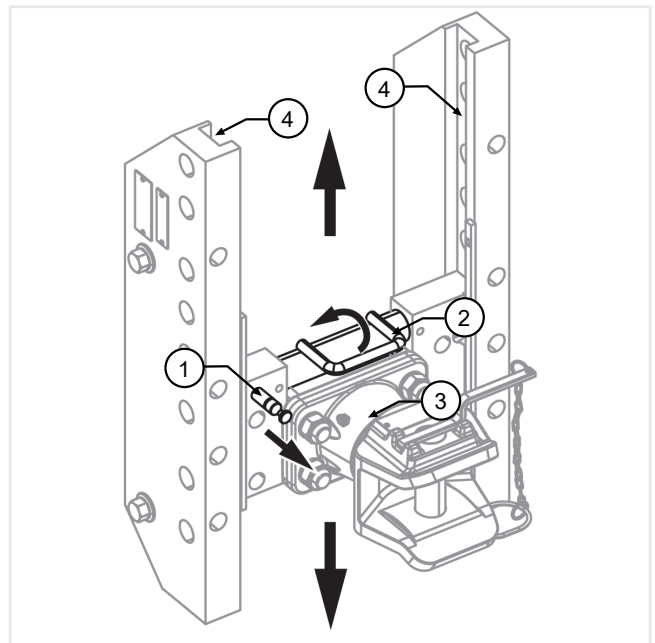

Figure: 150502-1



WARNING

The vehicle driving maneuverability and safety depends on the proper adjustment of the tow hitch.

The tow hitch located at the top increases the pulling capacity but also prevents the risk of tipping. Do not allow that the drawbar to position too tilted up.



DANGER

Be careful during the tow hitch height adjustment; danger of crushing of hands or feet.

Keep the guides "4" clean and lubricate according to the deadlines specified in the "Maintenance" chapter.

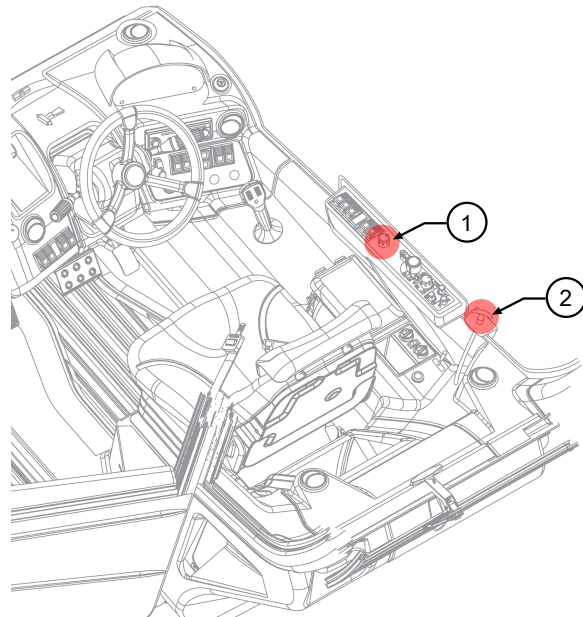

Figure: fig. 150503-2

9.10 - Pick-up hitch **



NOTE

The Pick-up hitch is an optional accessory for the agricultural sector.

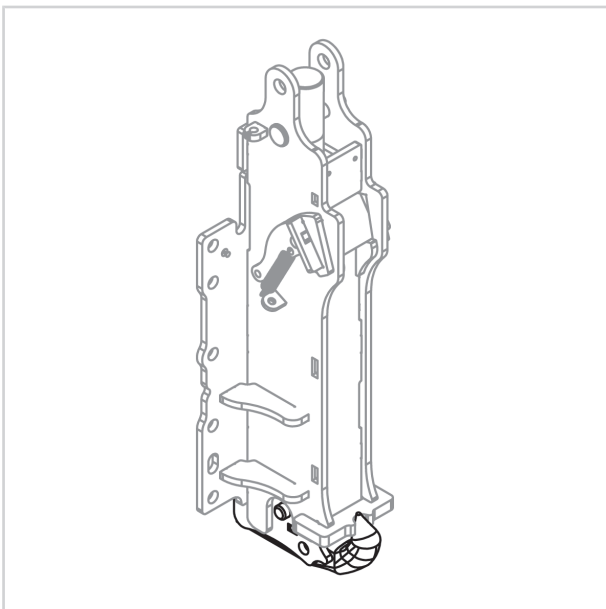

Fig. 150503-1

The pick-up hitch (fig. 150503-1) is placed in the rear of the vehicle and allows connecting the trailer to the vehicle directly from the cab.

To use the Pick-up hitch it is necessary to follow this procedure (fig. 150503-2):

1. Select the rear hydraulic socket to which is connected to the Pick-up hitch through the selector "1".
2. Pull the safety release "2" in the cab (the lever position can vary depending on the model of the vehicle).
3. Move the services roller on the joystick forward to bring down the Pick-up hitch.
4. Slowly reverse the vehicle to place the Pick-up hitch under the drawbar of the trailer.
5. Move the services roller on the joystick back to lift the Pick-up hitch and hook the trailer.
6. Lift the hook until the safety lock snaps.
7. Drive slowly to check that the hooking occurred successfully.

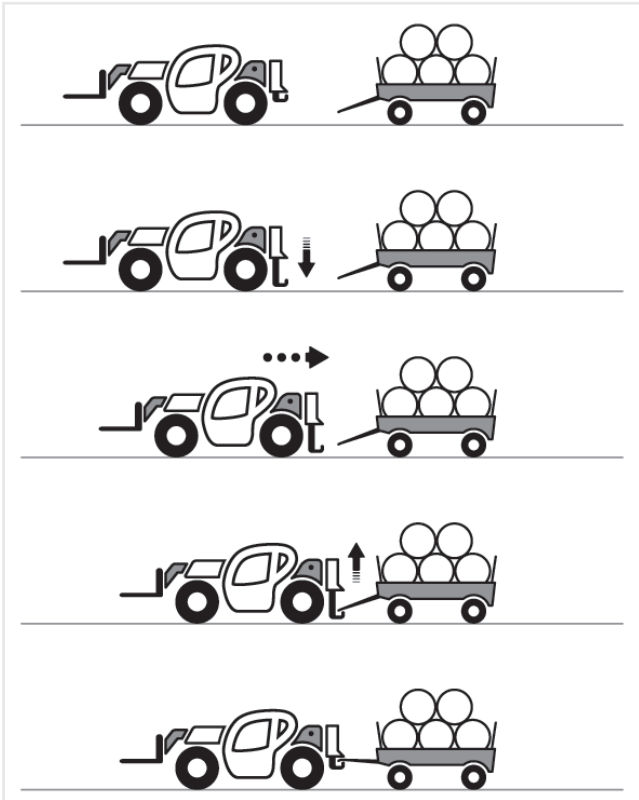













Figure: 150503-3



NOTE

The vehicle is supplied with the equipment useful for the vehicle use and maintenance.

	<p>Tool bag The tool carrier bag is made up of:</p>
	<p>Socket wrench</p>
	<p>Set of wrenches</p>
	<p>Screwdriver</p>
	<p>Lubricator</p>
	<p>Set of rubber plugs for quick couplings</p>
	<p>Rod for emergency recover pump (Only with man basket prearrangement)</p>
	<p>Adaptor cable for engine diagnostics (Only FPT engines Stage IIIB/Tier 4i version and following)</p>
	<p>Protruding load signal (only Italy)</p>
	<p>Rotating light</p>
	<p>Pin for vehicle tow hitch</p>
	<p>Pin for trailer hitch (only tractors)</p>

11.1 - General warnings on equipment use



DANGER

It is strictly forbidden to modify the structure of the equipment or adjust the safety devices of the various tool components.

- Only Equipment CE certified by the relative manufacturer can be used on *DIECI* vehicles, as well as equipment approved or falling within the technical limits set out by *DIECI S.r.l.* The guarantee is void if not approved equipment is used.
- The Tool does not require CE certification.
- *DIECI S.r.l.* liability shall not be involved if equipment use or modifications do not comply with the above mentioned requirements.



ATTENTION

The equipment installed on the vehicle may only be used:

- a) on consistent ground and with vehicle level with maximum tilt of 2°.
 - b) by competent and qualified personnel who must have read this manual. In the case of road use refer to the Use and Maintenance Manual of the vehicle making sure that the operator is in possession of a valid driver's license in accordance with the laws in force in the country of use (license B or higher for ITALY), and that the vehicle boom is in the fully retracted position.
- Some equipment be accompanied by instructions related to safety standards, connection and disconnection, operation and maintenance. Carefully read and fully implement these instructions prior to installation, use and maintenance of the equipment. In case of doubt, contact your local dealer.
 - Before starting to use the vehicle and related equipment, or before performing particularly complex or dangerous operations, it is absolutely necessary to practice in a clear work area free from obstructions.
 - In case of poor visibility of the zone use a person on the ground to coordinate the movements and operations and that monitors the area inviting people who might come, to go away. The

individual on the ground must stand at a safe distance from the vehicle in motion and alert, before any movement, any personal around.

- To prevent damaging hydraulic fittings when changing an equipment, stop the engine and wait a few seconds to remove pressure from the circuit. Always clean the fittings before their reinsertion.
- Check the cleanliness, protection and conditions of quick release joints in the equipment circuits and on the boom head daily.



DANGER

Never carry the equipment in the vicinity of an open flame.



DANGER

When using the vehicle, carefully follow the respective Load charts.

It is strictly prohibited to work without the respective load charts for the type of vehicle and installed equipment.

- The indications given by the anti-tipping system of the vehicle must be considered valid for standard working conditions, on flat and solid ground with well-operating and properly calibrated equipment. In any case, the values indicated by the load charts must be respected and never exceeded.
- It is mandatory, every time the equipment is used to insert the safety plugs to secure the equipment to the Attachment holding plate.
- If an attachment holding plate different from the original Dieci attachment holding plate is installed on the vehicle, a residual load will remain on the anti-tipping device of the vehicle as a safety factor.
- Refer to the manual of the manufacturer of the attachment holding plate installed if different than the original Dieci attachment holding plate.



ATTENTION

When moving the vehicle with equipment or man baskets installed, maintain a speed appropriate to the type of ground.

When driving on rough terrain it is advisable not to exceed 10 km/h (6,2 mph) to prevent vibration and pitching phenomena, damaging the equipment or the man basket installed on the vehicle.



WARNING

It is possible that in certain working conditions there is no interference between the attachment holding plate and/or the equipment and the vehicle chassis or wheels.

Pay due attention to prevent damage to the vehicle. Lift and extend the boom just enough to avoid interference.

11.1.1 - Equipment pre-use checks



NOTE

Refer to the pre-use safety procedures of the vehicle on which the equipment is installed.

Before every use and every time new equipment is installed on the vehicle:

- Check that the equipment is properly hooked to all the pins and the hooks are inserted in the correct position.
- There is no damage, deterioration, deformation of the equipment locking components.
- Check that the equipment and components are intact, perfectly operating and not damaged.
- Verify that the equipment capacity is more than the weight of the load to be moved.
- Verify the correct operation of the equipment and of the controls present in the vehicle cab on which the equipment is installed in a work zone free from personnel and obstacles.
- Verify the operation of all indicators and lights present inside the vehicle on which the equipment has been mounted.
- Check the tilting when empty.
- Check the oil level in the hydraulic circuit.
- Check that the safety symbols and stickers are clearly legible.
- Check the efficiency and operation of the safety devices.
- Visually check the state of welding, inspect the vehicle and check for cavities, cracks of the welding or base metal or other inconveniences.
- Check for any deformations and/or modifications of the material due to sudden temperature changes or damage from impacts.
- Check the equipment for wear.
- Verify the use mode relating to the installed equipment has been set on the vehicle.

- Verify that the Load charts relating to the vehicle and installed equipment are present on the vehicle.

In case of equipment with hydraulic connections:

- Check that the pipes are in good conditions and do not obstruct the movements of the boom or of the equipment.
- Verify the correct connection of the hydraulic pipes (if present) ensuring that the equipment functions are not inverted.

In case of equipment with electrical connections:

- Check that the cables are in good conditions and do not obstruct the movements of the boom or of the equipment.
- Clean and fasten all the electrical connections (if present). Check before each work shift that there are no loose, twisted, hardened or damaged electrical cables. Do not operate the operating vehicle if there are any loose, twisted, hardened or damaged electric cables.

In the event of radiocontrol pre-arrangement:

- Refer to the specific manual of the equipment for further checks.
- Verify the correct operation of the radiocontrol/push button control panel and the charge status of the batteries.

In case lifting equipment is used

- Refer to the specific manual of the equipment for further checks.
- Verify the integrity of the lifting hook, including relative catch, and of the hook bolt to the rope.

In case winches are used

- Refer to the specific manual of the equipment for further checks.
- Check that the rope is not damaged, cut, torn, frayed. On the contrary, do not use the equipment and replace it. (This check can be carried out by fully extending the lift boom and unrolling the winch rope). During this operation it is also possible to check the operation of the limit switch, which must lock the rope according to the procedure described in the specific paragraph.
- Verify the operation of the extensometric transducer of the mounted equipment (if present); to do this, try to lift a load slightly heavier than the nominal maximum capacity of

the equipment. In case the equipment is unable to lift the load, the transducer operates correctly, otherwise immediately interrupt the operation bringing the load to the ground and repair the equipment.

In case of using elevating work platforms

- Refer to the specific manual of the equipment for further checks.
- Verify the operation of the emergency button of the load limiter and of the area limiter at the beginning of each work cycle.
- Before using the platform ensure it is not wet, dirty with grease, oil, has icy surfaces or covered with other substances that can make its surface slippery. On the contrary, accurately clean and dry the platform surfaces. Danger of slipping and falling.
- The vehicle on which the equipment is installed must be braked and stabilized on solid ground. If outriggers (optional) are present, position them correctly on the ground before starting to operate.
- Before operating, make sure that the openings for access to the platform are in the closed position; always verify the correct engagement of the safety harnesses (PPE category III).



ATTENTION

All checks must be carried out by adequately trained personnel and registered on the control log.

If damage or malfunctioning is detected, comply with the instructions contained in this manual or in the manual of the equipment or basket or contact the DIECI Assistance Center to agree the actions to be taken.

If routine or extraordinary maintenance or technical adjustment of the equipment is required, contact exclusively personnel authorized by the DIECI Assistance Center and note the service intervention on the control log.

If the equipment is tampered with, the guarantee is voided and the Manufacturer is relieved of all liability.



DANGER

Operators who note anomalies on the equipment or on the vehicle on which it is installed, and it does not conform to safety regulations must suspend use and immediately inform the Person in charge.



NOTE

For road circulation, refer to the Use and Maintenance Manual of the vehicle on which the equipment is installed.

11.1.2 - Bucket warnings



WARNING

Pay special attention to the following indications on how to use the vehicle with a bucket.

- We recommend a limited and occasional use of the vehicle with bucket.
- Intensive use can damage the boom, so maintenance intervals should be halved.
- It is forbidden to push the bucket against the material with the extension movement.
- When pushing with the bucket against the material it is necessary to:
 - Keep the wheels straight;
 - Keep the boom closed;
 - Lower between the two chassis guides (if present);
 - Do not push the boom down lifting the two front wheels;
 - Do not excavate with the bucket
- It is forbidden to use buckets larger than those specified in the price list.
- It is forbidden to use buckets that are not "DIECI", in case you want to use buckets that are not "DIECI" contact the customer service.
- It is permitted to use the vehicle with the bucket only for carrying work.



ATTENTION

It is important that there is always visibility by the operator on the bucket work area. A bucket that is too large limits the operator's visibility and can damage the vehicle.

11.2 - Equipment installation procedure

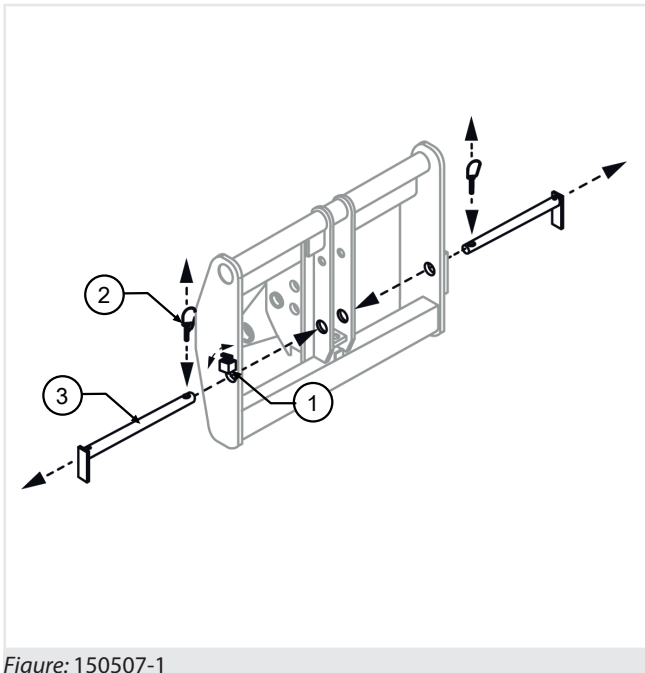

Figure: 150507-1

To properly install equipment carry out the following operations (fig. 150507-1):

1. Remove the safety plugs "3" (if installed) by removing the safety plugs "2" and lifting the lock pins "1".
2. Place the equipment on a flat not yielding surface, to be able to smoothly engage it with the attachment holding plate of the vehicle.
3. Place the vehicle with the boom lowered parallel to the tool. Approach the attachment holding plate to the accessory extending the telescopic boom. The vehicle can not extend the boom if it is completely lowered. Slightly raise the boom to be able to extend it.
4. Using the tilting movement, rotate the attachment holding plate downward. Bring the top of the plate under the locking hooks of the tool.
5. Slightly lift the boom and rotate the attachment holding plate upwards, thus making the equipment adhere to the attachment holding plate of the vehicle. During this operation, make sure that no person is in the vicinity of the equipment or the vehicle boom.
6. Turn off the engine and get out of the vehicle.
7. Lift the lock pin "1" and insert the safety pins "3" in their seats on attachment holding plate, passing through the corresponding slots of the equipment. If the two holes do not match, perform the steps described in chapter "Safety pin outline".
8. Fit the safety plug "2" on the pins just inserted.
9. In the event that the equipment needs electrical or hydraulic connections, refer to the chapters "Hydraulic connections" and "Electrical Connections [▶ 152]".
10. Once properly fixed the equipment, turn on the vehicle and set the correct mode of operation of the vehicle related to the newly installed equipment:
11. Consult the use and maintenance manual of the vehicle to set the correct mode of use.
12. Check that in the cab there is the load chart related to the vehicle and to the equipment just installed.

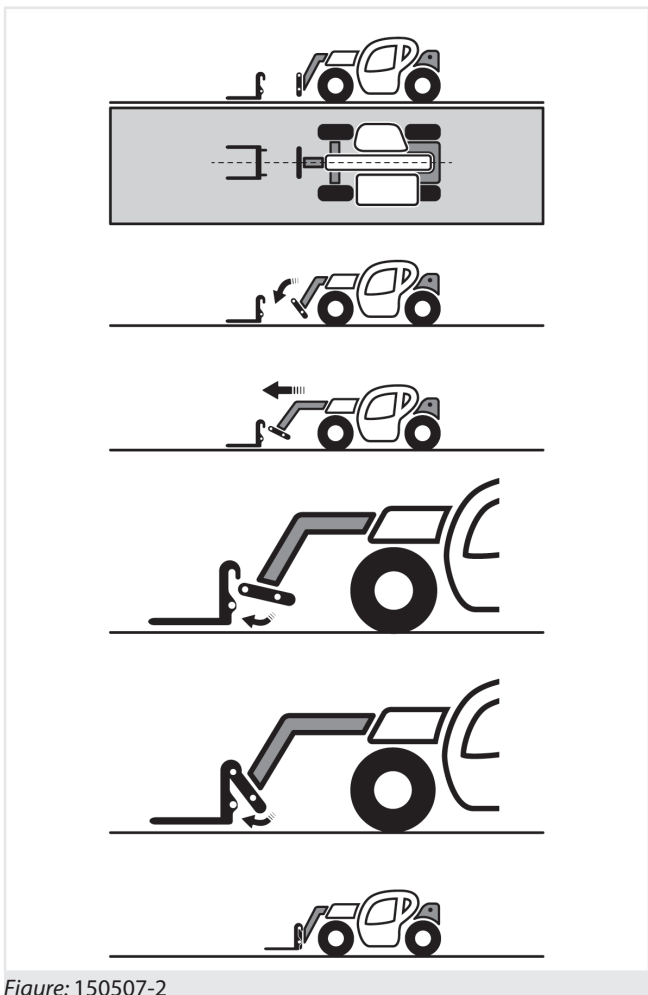

Figure: 150507-2



DANGER

In case, for deformation, the pin and the related safety pin do not reach the required position, it is absolutely forbidden to use the accessory as it may come off and fall to the ground dangerously.



DANGER

It is forbidden to operate without the safety pin installed on the attachment holding plate.



WARNING

When using an equipment that has electrical or hydraulic connections these must always be correctly connected to the vehicle. Failure to connect does not allow the proper operation of the safety devices with risk of damage to property and persons and risk of vehicle tipping.



DANGER

It is forbidden to operate with a mode of use of the vehicle not suitable for the type of equipment installed. The electro-hydraulic equipment will not work correctly and safety devices will not be in operation creating a risk of damage to property and people and the vehicle risk of tipping.



DANGER

It is forbidden to operate without the proper load chart related to the vehicle and to the equipment installed.

For more details on the accessory installation procedures or warnings, consult the use and maintenance manual of the accessory.



ATTENTION

Before each use, check that:

- a) The equipment is properly hooked to all the pins and hooks are inserted in the correct position.
- b) There is no damage, deterioration, deformation of the equipment locking components.
- c) If present, the electric cables or hydraulic hoses are in good condition and do not create hindrance while using the equipment.
- d) The mode of operation of the vehicle is consistent with the type of equipment installed.
- e) In the cab there are the load charts related to the vehicle and to the equipment installed.

11.3 - Hydraulic connections

11.3.1 - Warnings for hydraulic connections



NOTE

Before making the hydraulic connections, perform the "Equipment installation procedure" and check the equipment is correctly fixed to the vehicle.

Check the hydraulic pipes do not obstruct the movements of the vehicle or of the equipment as it may be damaged.

Consult the equipment manual to verify correct operation.



WARNING

When using an equipment that has electrical or hydraulic connections these must always be correctly connected to the vehicle. Failure to connect does not allow the proper operation of the safety devices with risk of damage to property and persons and risk of vehicle tipping.



NOTE

Always accurately clean the hydraulic connections before each coupling. If not used, both the hydraulic connections must be protected with adequate plastic caps.



WARNING

Do not use the vehicle or the equipment if the hydraulic pipes are worn or damaged, but repair or replace them.



WARNING

Once the hydraulic connections have been made, it is compulsory to verify that the controls are consistent with the operations carried out on the vehicle.

By inverting the connections, the accessory functions may be inverted compared to normal use, therefore, after having completed the equipment installation procedure, test the various functions in a free zone.



DANGER

Hydraulic liquid under pressure

Fine jets of hydraulic oil at high pressure can penetrate the epidermis. Keep hands and face at a safe distance from the pressurized fluid and wear goggles and protective gloves. Bring a piece of cardboard to the area of the suspected leak and then check for traces of liquid on the cardboard. If the liquid penetrates the skin immediately seek for medical advice.



DANGER

Hydraulic pressure

The leakage of hydraulic oil at operating pressure can cause injury: before connecting or disconnecting the hydraulic pipes, release the residual pressure from the hydraulic circuit. Prevent starting the engine with disconnected pipes.

11.3.2 - Type of hydraulic quick couplings

The hydraulic quick couplings at boom head can be of two types:

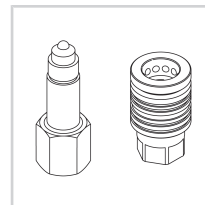

Push-Pull (fig. 150509-1)

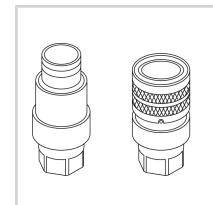

Flat-Face (fig. 150509-2)

11.3.3 - References for correct connection

To make the correct connection of the hydraulic fittings, each hydraulic plug or socket is marked with a color or symbol.

- The **red** plugs must be connected to the **red** sockets or those with the "+" mark.
- The **blue** plugs must be connected to the **blue** sockets or those with the "-" mark.

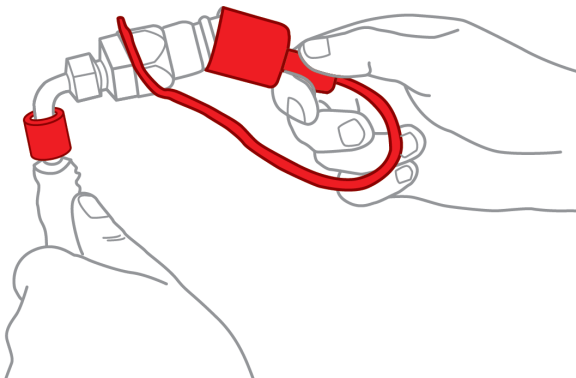

Figure: Cap and mark on the hydraulic sockets



Figure: Hydraulic sockets on boom head

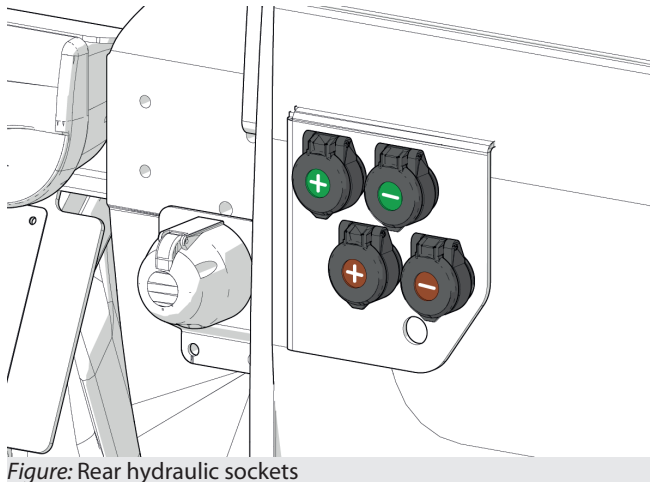

Figure: Rear hydraulic sockets



WARNING

Equipment with hydraulic connections made incorrectly have movements or functions that do not agree with the operator's controls and can cause damage to other operators, material handled or to the vehicle and equipment.

Always make sure that the hydraulic connections follow the indications given above for proper connection and that the movements and functions of the equipment comply with the operator controls.

11.3.4 - Push-Pull couplings connection

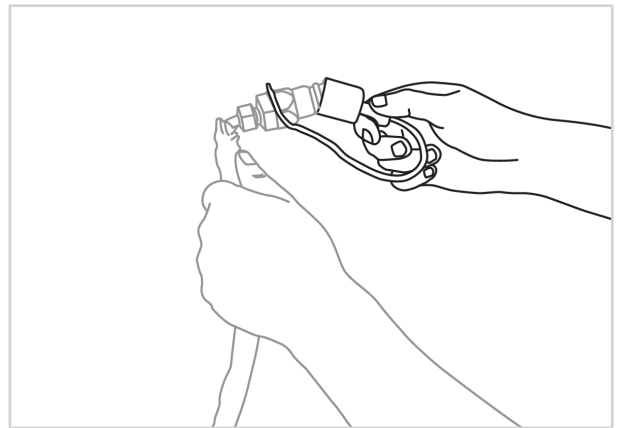

150510-1

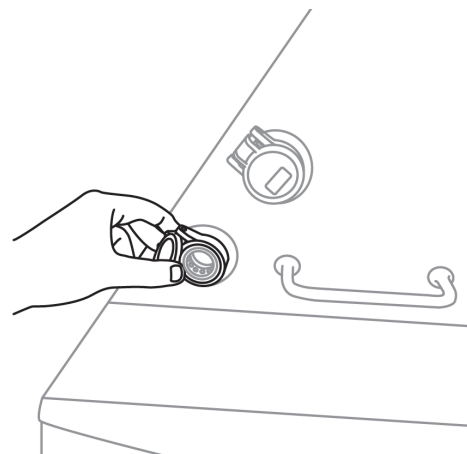

Figure: 150510-2

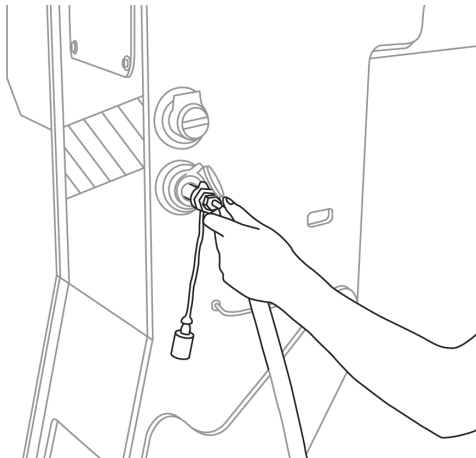

Figure: 150510-3

To connect the Push-Pull quick couplings to the sockets on the boom head:

1. Perform the equipment installation procedures described in the chapter: "Equipment installation procedure".
2. Turn off the vehicle.
3. In case of closed center distributor, discharge the system residue pressure (refer to chapter Closed center distributor: Relieve the pressure through the trailer Descent button).
4. Remove the protection cap from the equipment hydraulic plugs (fig. 150510-1).
5. Lift the protective cover for the hydraulic socket present on the boom head (fig. 150510-2).
6. Clean the plug and socket, if soiled.
7. Fit the plug inside the socket and press until the pipe is blocked (fig. 150510-3).
8. Check that the hydraulic pipe is correctly fixed.
9. Carry out the same operation for both pipes.



NOTE

Consult the equipment manual to verify correct operation.

11.3.4.1 - Push-Pull couplings connection when connected to a valve

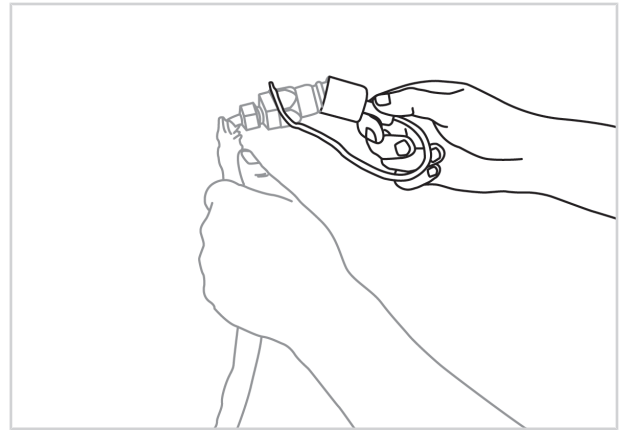

150511-1

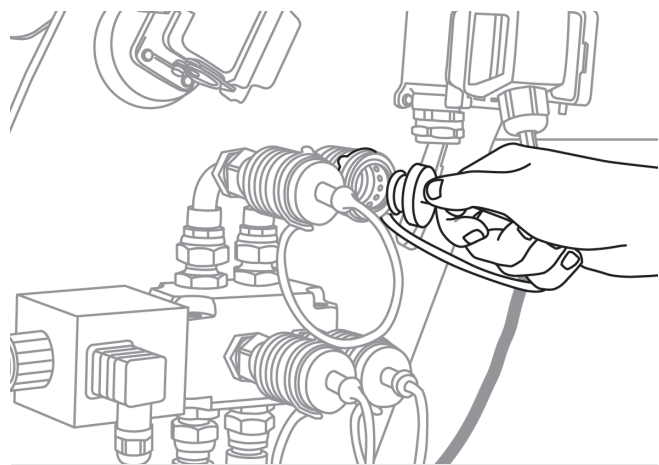

Figure: 150511-2

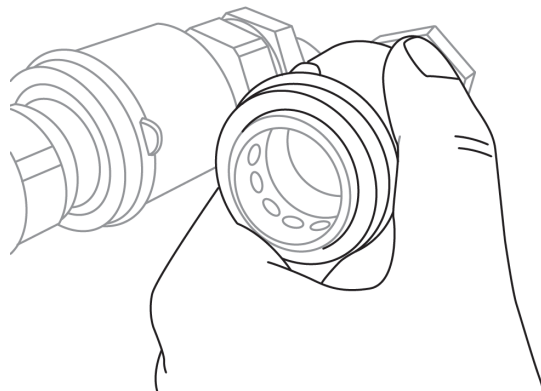

Figure: 150511-3

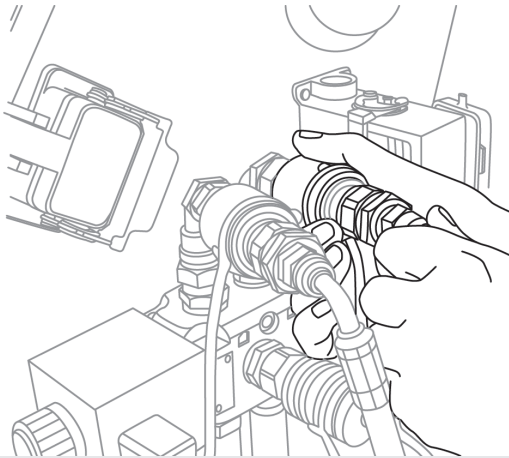

Figure: 150511-4

To connect the Push-Pull quick couplings to the valve on the boom head:

1. Perform the equipment installation procedures described in the chapter: "Equipment installation procedure".
2. Turn off the vehicle.
3. In case of closed center distributor, discharge the system residue pressure (refer to chapter Closed center distributor: Relieve the pressure through the trailer Descent button).
4. Remove the protection cap from the equipment hydraulic plugs (fig. 150511-1).
5. Remove the protection cap from the hydraulic sockets installed in the valve on the boom head (fig. 150511-2).
6. Clean the plug and socket, if soiled.
7. Push the ring on the valve socket towards the boom (fig. 150511-3).
8. Place the plug fully inside the socket and release the ring of the valve (fig.150511-4).
9. Check that the hydraulic pipe is correctly fixed.
10. Carry out the same operation for both pipes.



NOTE

Consult the equipment manual to verify correct operation.

11.3.5 - Flat-Face couplings connection

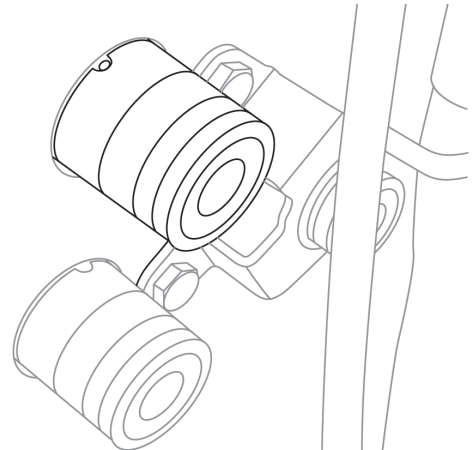

Figure: 150512-1

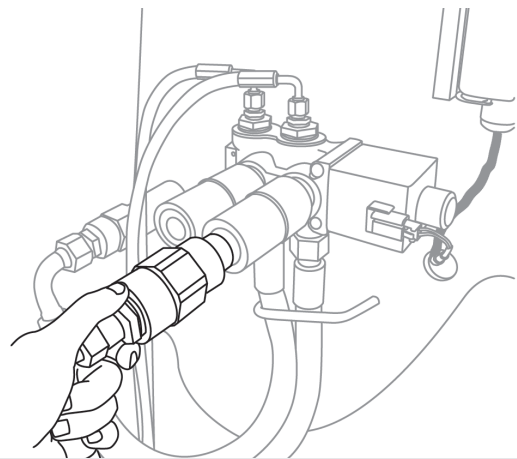

Figure: 150512-2

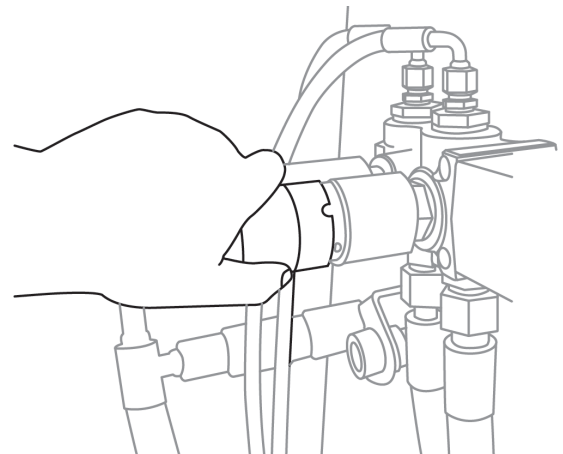

Figure: 150512-3

To connect the Flat-Face quick couplings:

1. Perform the equipment installation procedures described in the chapter: "Equipment installation procedure".
2. Turn off the vehicle.

3. In case of closed center distributor, discharge the system residue pressure (refer to chapter Closed center distributor: Relieve the pressure through the trailer Descent button).
4. Clean the plug and socket, if soiled.
5. Rest the plug at center of the socket and push the fully plug (fig. 150512-2), until the socket ring is lifted.
6. Turn the ring to block the plug inside the socket (fig. 150512-3).
7. Check that the hydraulic pipe is correctly fixed.
8. Carry out the same operation for both pipes.



NOTE

Consult the equipment manual to verify correct operation.

11.3.6 - Closed centre distributor: Relieve the pressure through the trailer Descent button*



NOTE

This operation is possible and it may be required only for vehicles fitted with "Closed centre distributor" and "Trailer descent".

Consequences



150501-1

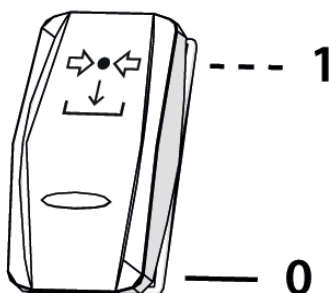

Figure: fig. 150501-2

To relieve pressure it is necessary to:

1. Move the ignition key of the vehicle to position "I" (fig. 150501-2).
2. Select the hydraulic socket still under pressure (if there is more than one hydraulic socket refer to the vehicle manual, chapter "Hydraulic sockets selection").

11.4 - Electrical Connections

11.4.1 - Warnings for electrical connections



DANGER

Before making the electrical connections, switch off the vehicle.

Do not use the vehicle or the equipment if the electrical cables are worn or damaged, but repair or replace them.



WARNING

Do not leave the boom plug hanging from the chain during work operations as this may be damaged impairing the vehicle correct operation when used without equipment.



ATTENTION

Before making the electrical connection, perform the "Equipment installation procedure" and check the equipment is correctly fixed to the vehicle.



WARNING

When using an equipment that has electrical or hydraulic connections these must always be correctly connected to the vehicle. Failure to connect does not allow the proper operation of the safety devices with risk of damage to property and persons and risk of vehicle tipping.

Consult the equipment manual to verify correct operation.



ATTENTION

Check that the electrical cable is not in a position that hampers the movements of the operating vehicle and of the equipment as it could be damaged.

11.4.2 - Procedure for connecting electrical connections

The electrical connections on the boom head may be at 6 or 24-pole, but the connection procedure is the same for both.

For equipment provided with electrical system carry out the following operations:

1. Perform the equipment installation procedures previously described.
2. Turn off the vehicle.
3. Disconnect the cover from the socket on the boom "1" (fig. 150512-1) lowering the 2 safety levers "2".

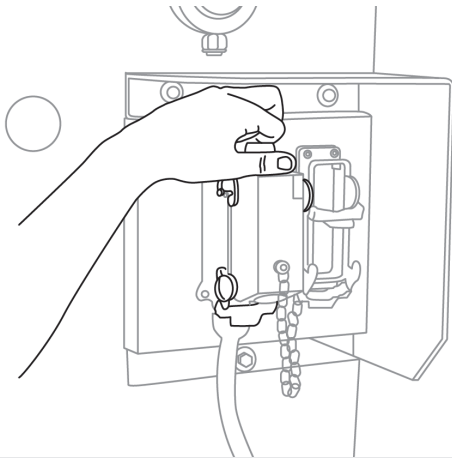

Figure: fig.150512-1

4. Remove the cover located on the boom socket and fit it in the dummy socket aside (fig. 150512-2) and fasten it with the appropriate levers.

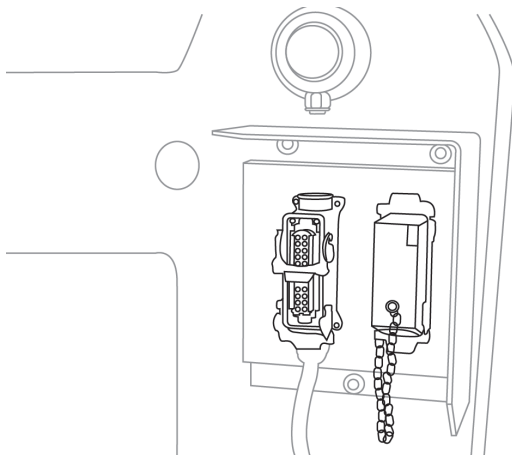

Figure: fig. 150512-2

5. Disconnect the plug from the dummy socket on the equipment "1" (fig. 150512-3) lowering the 2 safety levers "2" (fig. 150512-3).

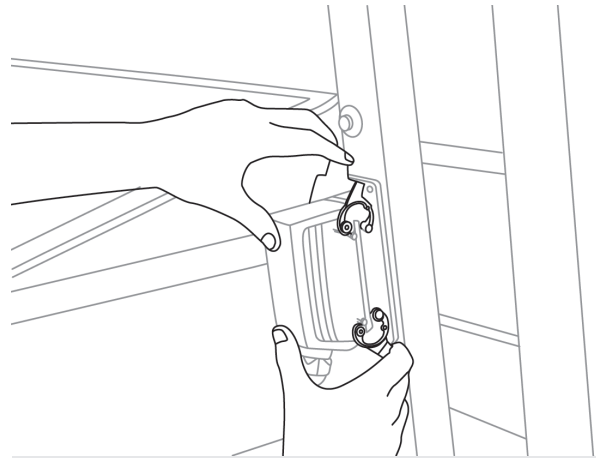

Figure: fig. 150512-3

6. Connect the plug of the equipment on the electrical socket of the boom, fastening it by lifting the 2 safety levers "1" (fig. 150512-4).

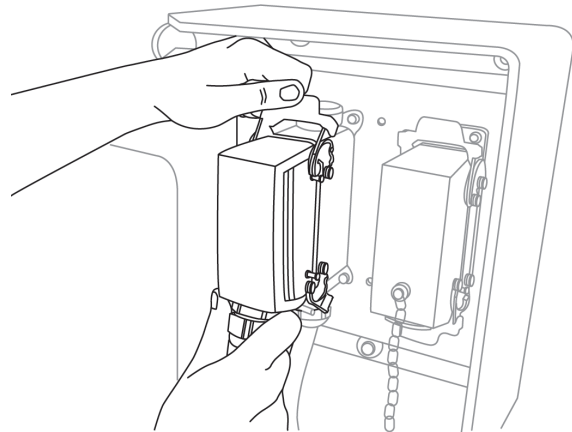

Figure: fig. 150512-4

7. Once the equipment is properly fixed, turn on the vehicle and set the correct mode of operation of the vehicle related to the newly installed equipment.
8. Check that in the cab there is the load chart related to the vehicle and to the equipment just installed.

11.5 - Equipment removal

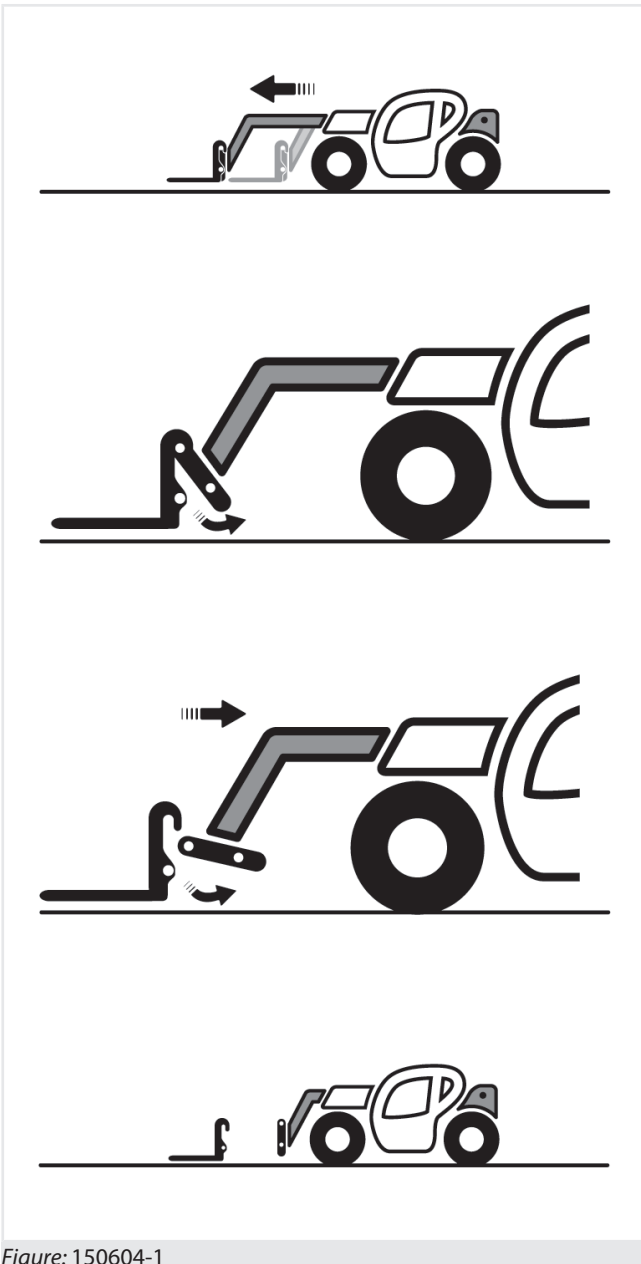

Figure: 150604-1

To store the accessory, once you finished using it, carry out the following operations:

1. Place the vehicle on a solid and level ground.
2. Position the equipment above a support platform to facilitate the handling and transportation of the single piece of equipment.
3. Lower and extend the vehicle boom of about one meter.
4. Turn off the engine.
5. Remove the electrical connections, if any (see the following chapter).
6. Remove the water connections, if any (see the following chapter).

7. Release the equipment following the reverse procedure of the equipment installation in accordance with the type of plate installed on the vehicle.
8. Turn on the vehicle and swing down in order to release the attachment holding plate from the equipment.
9. Once released the attachment holding plate, retract the vehicle boom.



NOTE

The accessory placed on the ground must always be appropriately marked and barriers and clearances must be laid on all sides of the area that it could occupy falling.



DANGER

After releasing the system pressure always wait for a minute before disconnecting the joints.

Always disconnect the hydraulic pipes and electrical cables of the equipment before releasing it from the vehicle. Otherwise it is possible to damage the pipes or cables and the tool may fall and be dragged.

11.5.1 - Electrical connections removal

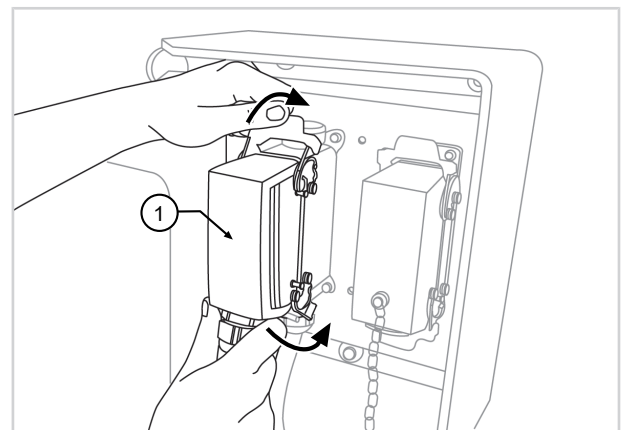

150514-1

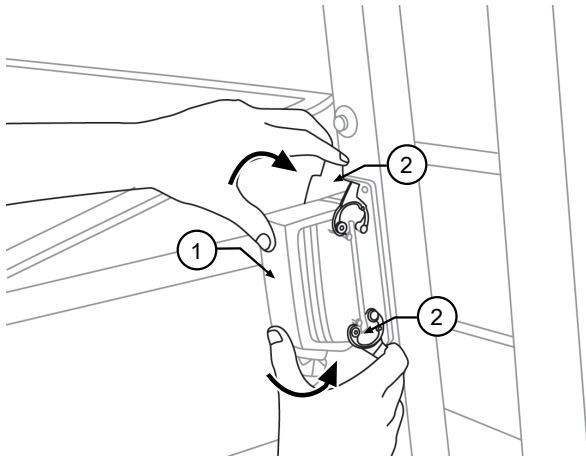

Figure: 150514-2

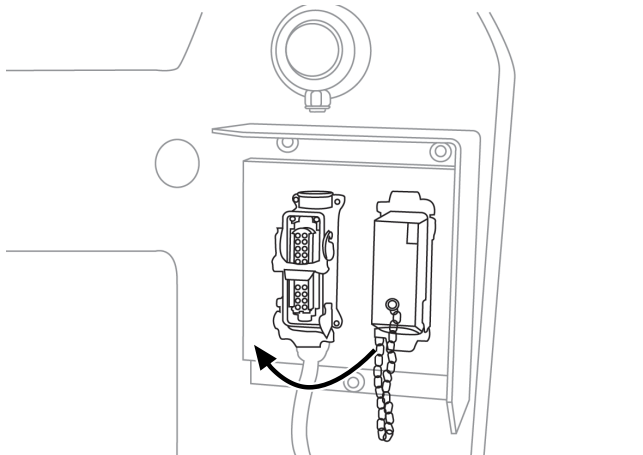

Figure: 150514-3

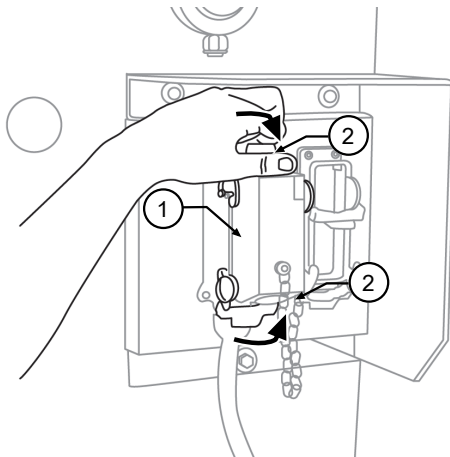

Figure: 150514-4

To remove the electrical connections from the equipment it is necessary to:

1. Follow steps 1, 2, 3 and 4 of the procedure to remove the equipment from the vehicle described in the previous chapter.
2. Disconnect the plug of the equipment from the boom lowering the two safety levers (fig. 150514-1).
3. Position the plug of the equipment on its dummy socket "1" (fig. 150514-2), fastening it with the safety levers "2".

4. Disconnect the cover located on the boom dummy socket and fit it in the electrical socket (fig. 150514-3).
5. Secure the cover to the socket on the boom "1" (fig. 150514-4) through the safety levers (fig. 150514-4).
6. Check that the electrical cables are not trapped in the attachment holding plate or that they can be crushed by the equipment when it will be placed on the floor.
7. Proceed with the subsequent operations to remove the equipment from the vehicle.

11.5.2 - Push-Pull couplings removal

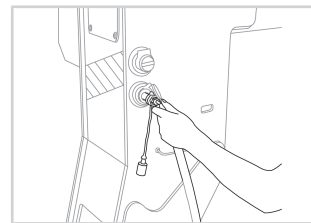

150513-1

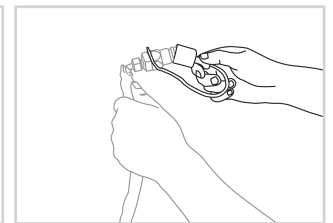

150513-2

To disconnect the Push-Pull quick couplings from the socket on the boom head it is necessary to:

1. Follow steps 1, 2, 3 and 4 of the procedure to remove the equipment from the vehicle described in the previous chapter.
2. If a closed center distributor is installed on the vehicle, carry out the procedures described in the "Closed center distributor: Relieve the pressure through the trailer Descent button *" chapter to release pressure in the hydraulic circuit.
3. Turn off the vehicle.
4. Pull the plug towards yourself to remove it from the socket (fig. 150513-1).
5. Clean the plug and socket, if soiled.
6. Fit the protection cap to the equipment hydraulic plugs (fig. 150513-2).
7. Carry out the same operation for both pipes.
8. Check that the hydraulic pipes are not trapped in the attachment holding plate or that they can be crushed by the equipment when it will be placed on the floor.
9. Proceed with the subsequent operations to remove the equipment from the vehicle.

11.5.2.1 - Push-Pull couplings removal when connected to a valve

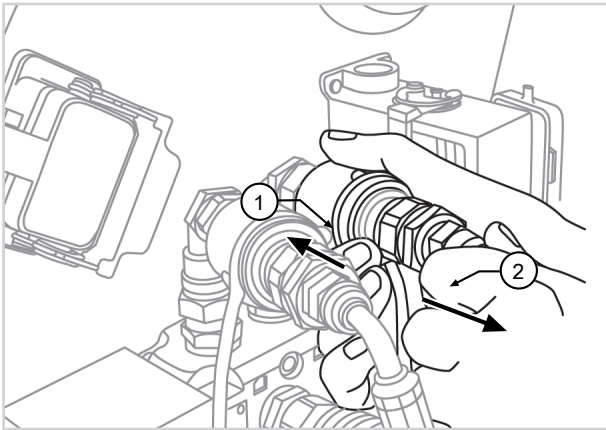

150515-1

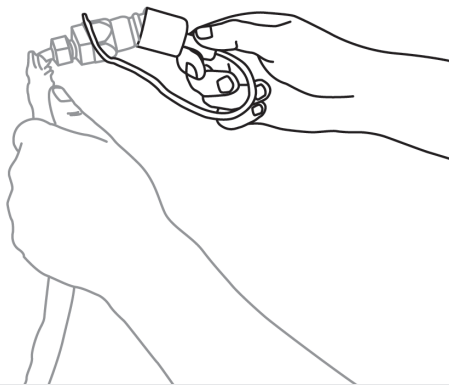

Figure: 150515-2

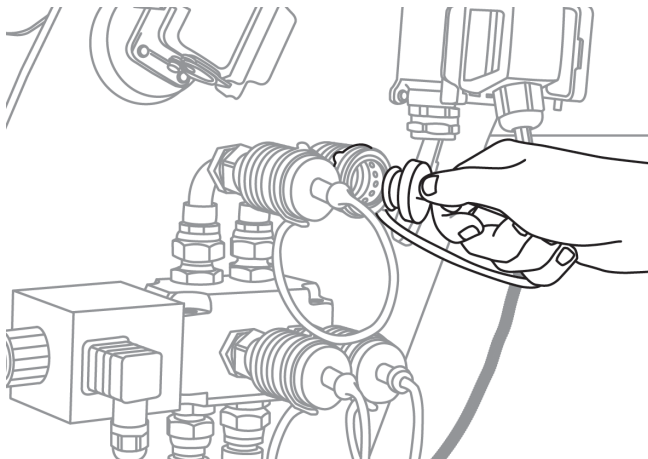

Figure: 150515-3

To disconnect the Push-Pull quick couplings from the valve on the boom head:

1. Follow steps 1, 2, 3 and 4 of the procedure to remove the equipment from the vehicle described in the previous chapter.

2. If a closed center distributor is installed on the vehicle, carry out the procedures described in the "Closed center distributor: Relieve the pressure through the trailer Descent button *" chapter to release pressure in the hydraulic circuit.
3. Turn off the vehicle.
4. Push the ring of the socket towards the vehicle boom "1" (fig. 150515-1).
5. Pull the plug towards yourself to remove it from the socket "2".
6. Clean the plug and socket, if soiled.
7. Fit the protection cap to the equipment hydraulic plugs (fig. 150515-2).
8. Fit the protection cap to the hydraulic sockets of the valve (fig. 150515-3).
9. Carry out the same operation for both pipes.
10. Check that the hydraulic pipes are not trapped in the attachment holding plate or that they can be crushed by the equipment plate when it will be placed on the floor.
11. Proceed with the subsequent operations to remove the equipment from the vehicle.

11.5.3 - Flat-Face couplings removal

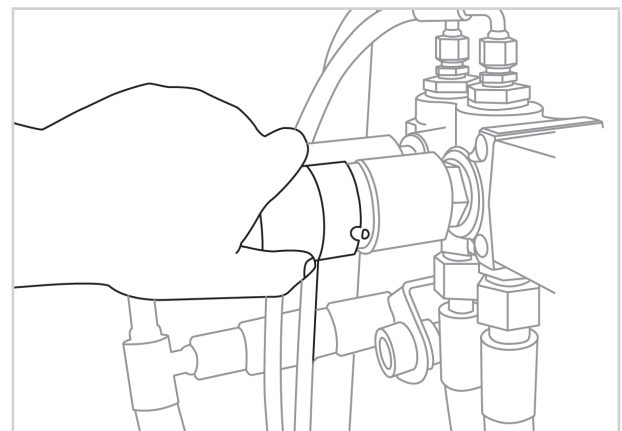

150516-1

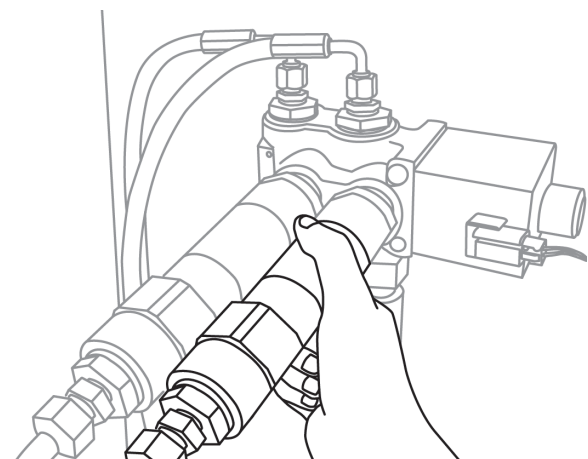

Figure: 150516-2

To disconnect the Flat-Face quick couplings:

1. Follow steps 1, 2, 3 and 4 of the procedure to remove the equipment from the vehicle described in the previous chapter.
2. If a closed center distributor is installed on the vehicle, carry out the procedures described in the "Closed center distributor: Relieve the pressure through the trailer Descent button *" chapter to release pressure in the hydraulic circuit.
3. Turn off the vehicle.
4. Turn the socket ring to match the recess with the position of the ball placed on the socket (fig. 150516-1).
5. Push the socket ring "1" (fig. 150516-2).
6. Pull off the plug "2" (fig. 150516-2).
7. Clean the plug and socket, if soiled.
8. Carry out the same operation for both pipes.
9. Check that the hydraulic pipes are not trapped in the attachment holding plate or that they can be crushed by the equipment when it will be placed on the floor.
10. Proceed with the subsequent operations to remove the equipment from the vehicle.

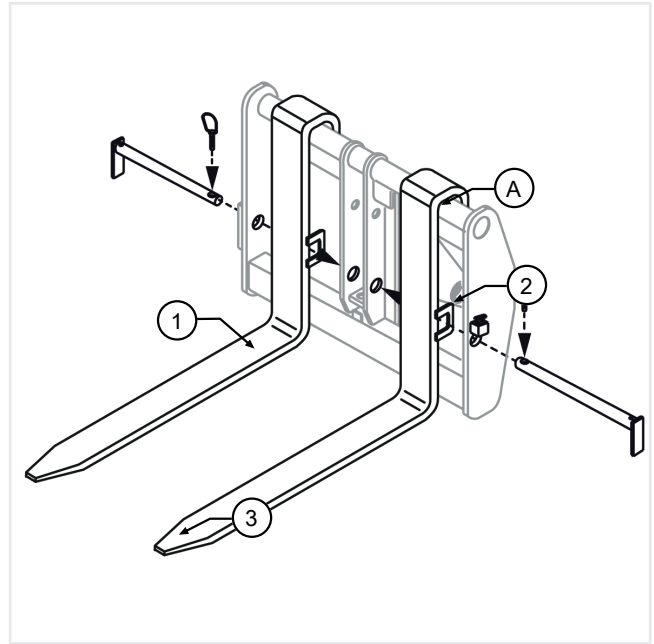

Figure: 150518-1

The data necessary for the identification of the forks are positioned on the right side of the forks, in the upper part "A" (fig. 150518-1).

Below are the identification data (their order may be different on the forks).

To ensure a prompt and efficient service when ordering parts or when requesting information or technical clarification always specify the identification details.

Therefore we recommend to note the data relating to the accessory in your possession in order to safely and quickly identify them in the future, in case of need.

11.6 - Forks

11.6.1 - Identification

The term "Forks" means the pair of forks to be installed on the vehicle.

The purpose of this equipment is the lifting and handling of a load from the ground upwards, and vice versa.



NOTE

The forks may be provided with a spreader/shifter that allows to position the distance between the forks more quickly and safely.

<i>Dieci</i> forks code
Manufacturer's Logo/Abbreviation
Manufacture Date/Batch
Maximum capacity (Kg)
Load application center of gravity (mm) *

* There may be more than one value depending on the load.

11.6.2 - Description

The forks (fig. 150518-1) consist of the following main components:

1. Forks
2. Eyelet

- Hole for mounting specially designed equipment



DANGER

It is strictly forbidden to use the Hole for fastening equipment, for the installation of equipment not expressly approved by Dieci or for a use other than that intended.

Vehicle tipping danger, damage to forks or falling materials.

11.6.3 - Forks check



NOTE

For the forks verification frequency refer to the "Control log".



ATTENTION

During maintenance and control, it is mandatory to use the appropriate Personal Protective Equipment.



WARNING

It is absolutely forbidden to carry out maintenance on the forks (e.g. welding, drilling, engraving, etc ...).

In the event of damage or deformation immediately replace the forks.

Check the forks thickness.

The maximum wear allowed is **10%** (fig. 150520-1).

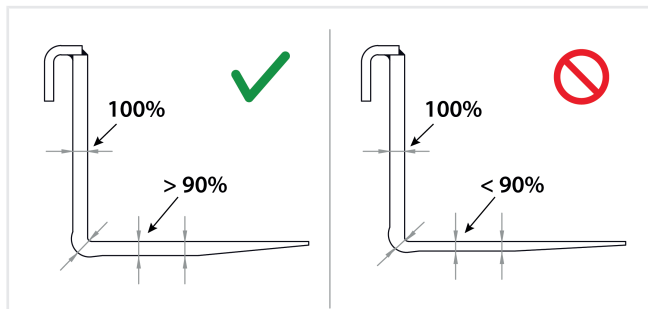

Figure: 150520-1

For example for a fork 70 mm thick, the thickness must not be less than 63 mm. (70 - 10% = 63)

For a quick check of the thickness of the forks, it is necessary to measure the thickness in the vertical part of the fork "1" (fig. 150520-2); this will be the

dimension to which refer for the fork thickness measurements "2" (fig. 150520-2). Make at least three measurements at several points.

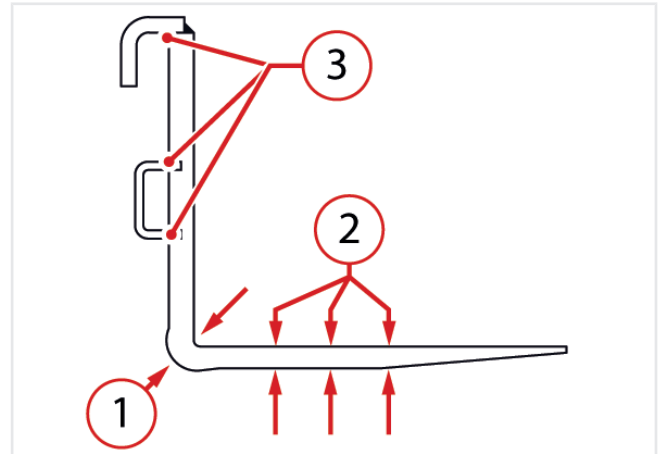

Figure: 150520-2

Verify the deformation of the forks

Verify that the two forks are parallel between them and that the distance from the ground is the same for both, or with difference of less than **3%** of the length of the fork (fig. 150520-3).

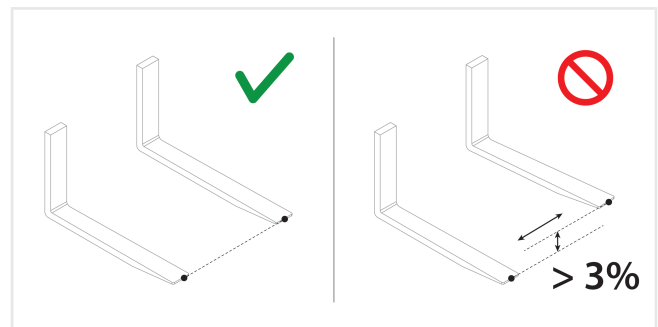

Figure: 150520-3

For example, for a fork 1800 mm long, the difference between the maximum permissible deformation of the fork tips will therefore be of 54 mm (1800 x 3/100 = 54).

Check the integrity of the welds

Check that all the welds on the forks "3" (fig. 150520-2) are in good conditions and have no cracks or anomalies.

11.6.4 - Forks use



ATTENTION

Before starting to use the equipment, inspect and test it as described in the section "Equipment pre-use check".



WARNING

It is absolutely forbidden to use the forks or any type of equipment, without securing it to the attachment holding plate with the appropriate safety plugs.



DANGER

Before each use, check the wear status of the forks, they could be worn out and not hold the load to be handled creating a dangerous situation.

Before starting to use the equipment, refer to the chapters:

- a) "Safety regulations"
- b) "Forks safe working procedures [▶ 160]"
- c) "Forks check [▶ 158]"

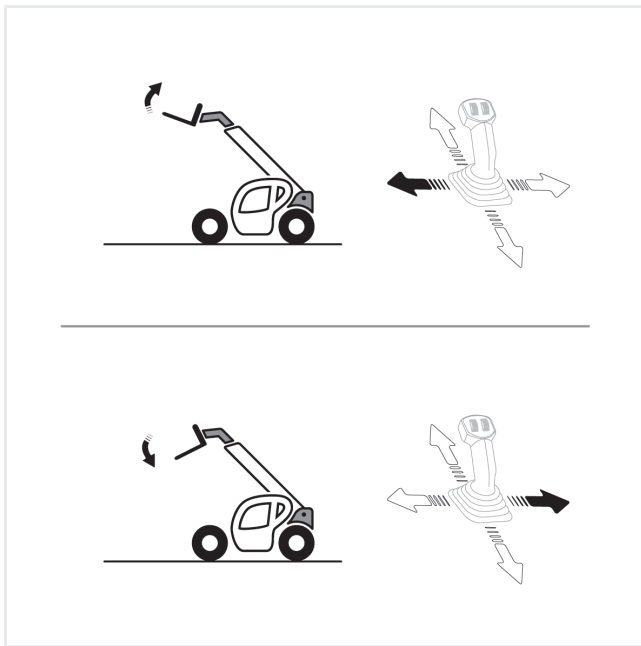

Figure: 150521-1

To use the forks it is sufficient to move the controls for the plate tilting.

By moving the joystick to the left, the tips of the forks will rise; by moving the joystick to the right, the tips of the forks will drop.

11.6.5 - Forks adjustment

To adjust the position of the forks it is necessary to:

- Deposit a load to the ground.
- Lower and fully retract the boom moving the forks to about 1 m above the ground.
- Turn off the vehicle.

- Get off the vehicle and manually move the forks to the desired width.

11.6.6 - Fork block

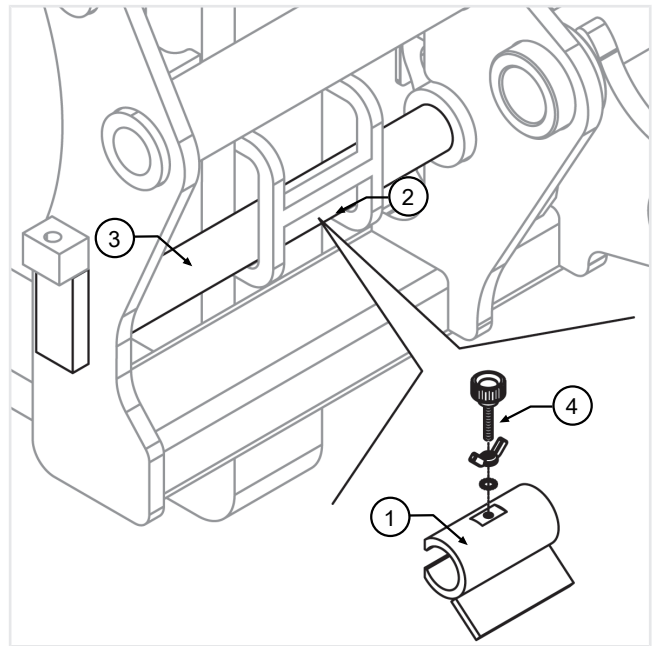

Figure: 150517-1

The Forks block prevents lateral movement of the forks once the desired setting has been chosen.

To engage the forks block (fig. 150517-1):

1. Perform the forks installation procedure on the fork carrier plate.
2. Place the forks block "1" in the eyelet of the forks "2".
3. Insert the plug "3" completely down in order to fit the eyelet "2" and the fork block "1".
4. Fasten the plug with the related safety stops.
5. After moving the fork laterally to the desired position, fix the position by tightening the screw "4".

11.6.7 - Fork extensions



ATTENTION

Before starting to use the equipment, inspect and test it as described in the section "Forks Safe Working Procedures".

Before starting to use the equipment, refer to the "Safety regulations" and "Safe Working Procedures" described in the manual of the vehicle on which the equipment is installed.

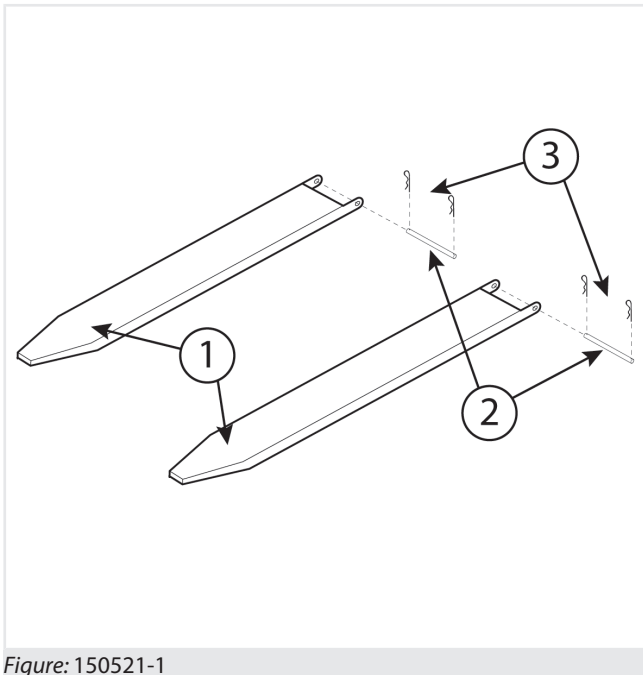

Figure: 150521-1

The fork extensions consists of the following main components (fig. 150521-1):

1. Extension
2. Fastener pin
3. Safety plug

Warnings for use

- Use the extensions only with the forks for which they were constructed.
- Before use, check their integrity.
- Always apply the pin with the related cotter pin.
- Do not use loads exceeding those indicated by the forks on which the fork extensions are mounted.
- Refer to the load chart of the forks to which are applied the fork extensions.
- Make sure of the load stability.
- Do not take the load with a single extension.
- Do not use extensions for purposes other than those for which they were constructed.

Installation

- Fit the extension on the forks after establishing the integrity of the extension and the forks.
- Put the fastener pin "2" with the related safety plug "3".



DANGER

Never use if the forks or the extensions if they are defective or show tampering signs.

Forks extension check

- At each use check the integrity of welds and repair if necessary.
- When the thickness of the lower metal sheet reaches 80% of its original thickness, the extension must be replaced.

11.6.8 - Forks safe working procedures

11.6.8.1 - General instructions on forks use



DANGER

Never lift a load slung with a single fork or with a board.

It is absolutely forbidden to use the forks with hooks, straps or other materials for handling suspended loads. Use the appropriate accessories (hook, winch, jib).

- Always set the forks fully under the load and move it to the transport position (forks at 300mm from the ground and tilted backwards, with fully retracted boom).
- The load diagrams are valid for centers of gravity indicated on the diagram. For a center of gravity at a greater distance, contact your dealer.
- Pay attention to the risk of crushing limbs when adjusting the forks manually.
- It is absolutely forbidden to increase the length or width of the forks with extensions not provided directly by the Manufacturer. In this case DIECI is raised from any responsibility regarding their use.
- Forks overloading and transverse stress are strictly prohibited.
- Place the forks to their maximum possible width depending on the load to be moved. Before lifting a load make sure that the width of the forks corresponds to that of the pallet or that these can withstand the weight of the load on the pallet. Forks set wide apart maintain a stable load.
- Place loads evenly on the forks, to obtain a stable balance. When lifting wide loads, or not centered and that are impossible to center, maneuver the vehicle with caution in order to prevent this from tipping. Use caution when lifting bars of considerable length.
- Do not raise the load with the tip of the forks facing downwards. The forks must always be with the tips pointing upwards; in this way the load will lean against the plate of the forks. A lifted

load can be tilted forward only if it must be placed on a stack or directly on a discharge surface.

- Do not use the vehicle to transport or move persons when the forks are assembled on it. Use suitable interchangeable equipment approved by Dieci.

11.6.8.2 - Load transport position with forks



Figure: 150527-1

To correctly transport a load with forks it is necessary to:

1. Fully retract the boom.
2. Lower the boom fully down so that the forks are at about 300 mm from the ground.
3. Tilt the fork tips upward.

11.6.8.3 - Picking up a load from the ground

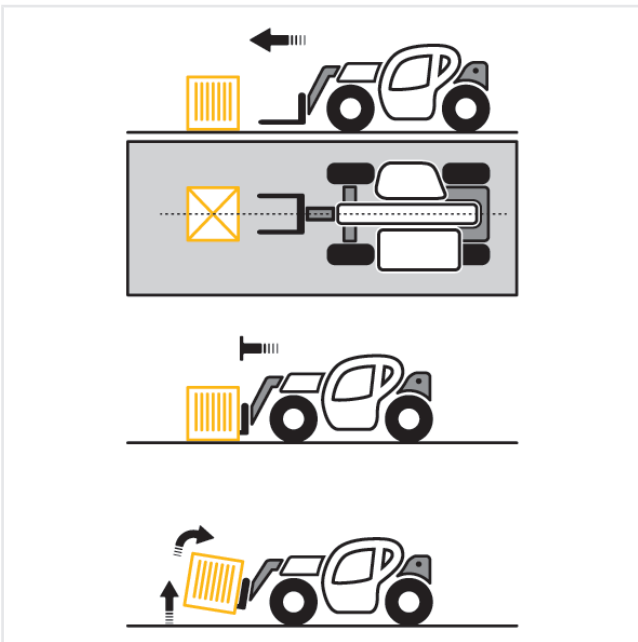

Figure: 150528-1

1. Slowly move the vehicle to the load to be lifted with the boom fully retracted and the forks in a horizontal position at the height of the lifting position. Keep the forks raised just enough to avoid contact with the ground.
2. Bring the forks under the load to be lifted up to the contact with the attachment holding plate.
3. Press the brake pedal and move the gear selector in neutral.
4. Slightly lift the load and tilt the attachment holding plate backward setting it in the transport position.



WARNING

Always observe the center of gravity of the load, tilt the forks enough to ensure stability and prevent the loss of the load during braking.



DANGER

Never carry a load with boom raised and/or removed.

11.6.8.4 - Picking up a load from a high position

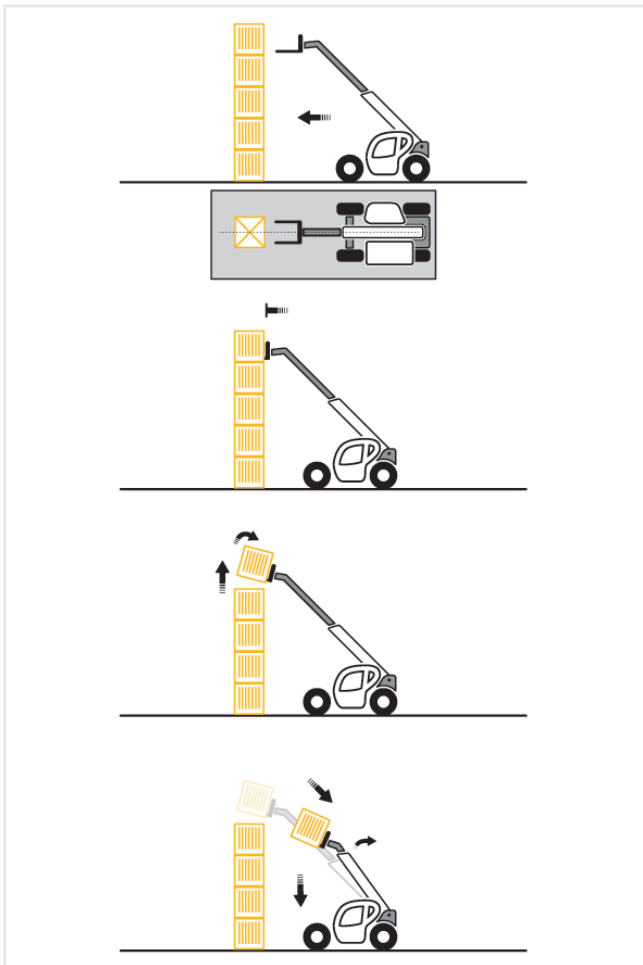

Figure: 150529-1

1. Make sure that the forks pass easily under the load.
2. Drive slowly and cautiously approaching the vehicle to the load placing it perpendicular to this with the forks horizontal. If necessary, use the inching pedal to approach slowly.
3. Always remember to keep the distance required to insert the forks under the load, between the stack and the vehicle.
4. Extend the boom for the shortest possible length.
5. After bringing the forks under the load to be lifted until it is in contact with the fork holding plate, press the brake pedal and move the gear selector in neutral.
6. Lift the load and tilt the fork holding plate to the transport position.
7. If possible lower the load without moving the vehicle.
8. Lift the boom to move the load away, then retract the extensions and lower the boom to set the load in the transport position.

9. If not possible, move the vehicle backward very slowly and very carefully, after moving the load away properly retract the extensions and lower the boom to set the load in the transport position.



WARNING

Always observe the center of gravity of the load, tilt the forks enough to ensure stability and prevent the loss of the load during braking.



DANGER

Danger of tipping

It is absolutely forbidden to pick up a load if the vehicle is not level.

Never carry a load with boom raised and/or removed.

11.6.8.5 - Positioning a load in a high position

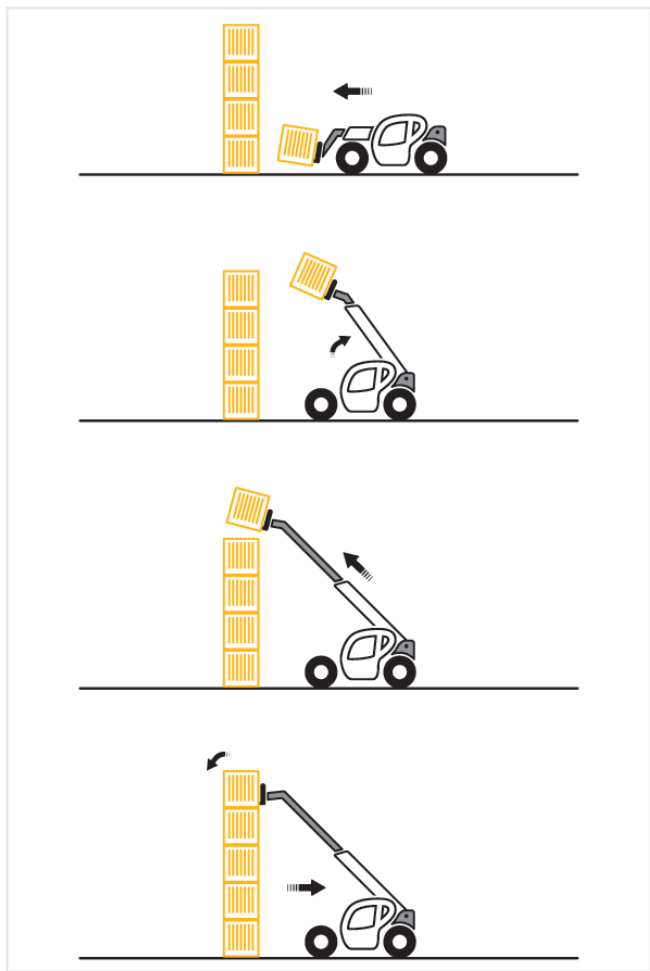

Figure: 150530-1

1. Bring the load in the transport position in front of the stack.

2. Lift and extend the boom to take the load above the stack. If necessary, move the vehicle towards the stack very slowly and very carefully. If necessary, use the inching pedal to approach slowly.
3. Press the brake pedal and move the gear selector in neutral.
4. Place the load horizontally and lay it on the stack, lower and retract the extensions to properly position the load.
5. Release the forks alternately retracting the extensions and lifting the boom; if possible make the vehicle move back very slowly and very carefully.



WARNING

Always observe the center of gravity of the load, tilt the forks enough to ensure stability and prevent the loss of the load during braking.



DANGER

Danger of tipping

It is absolutely forbidden to pick up a load if the vehicle is not level.

Never carry a load with boom raised and/or removed.



WARNING

Always observe the center of gravity of the load, tilt the forks enough to ensure stability and prevent the loss of the load during braking.



DANGER

Never carry a load with boom raised and/or removed.



NOTE

There are various interchangeable equipment such as grippers to facilitate the work with objects which are round, contact your DIECI dealer.

11.7 - Bucket

11.7.1 - Buckets identification

Buckets allow handling inert material.

To ensure a prompt and efficient service when ordering parts or when requesting information or technical clarification always specify the serial number.

Therefore we recommend to note the data relating to the accessory in your possession in order to safely and quickly identify them in the future, in case of need.

The data necessary for the identification of the buckets are positioned on the right side, in the upper part "A" (fig. 150522-1).

11.6.8.6 - Picking up a round load

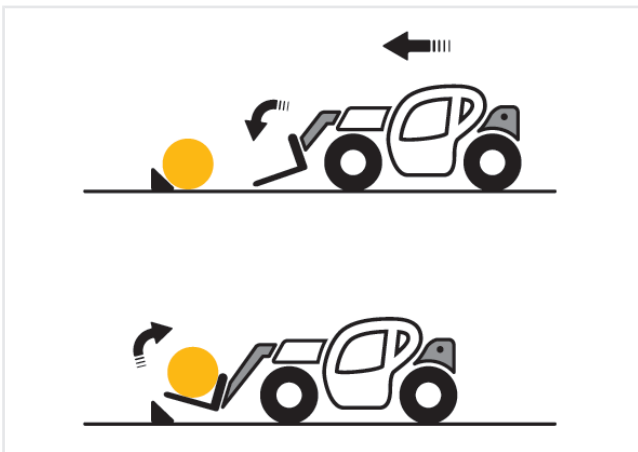

Figure: 150531-1

1. Tilt the forks forward and retract the telescopic boom, while inserting the forks under the load.
2. Rotate the fork carrier plate backward to slide the load. If necessary secure the load with wedges.

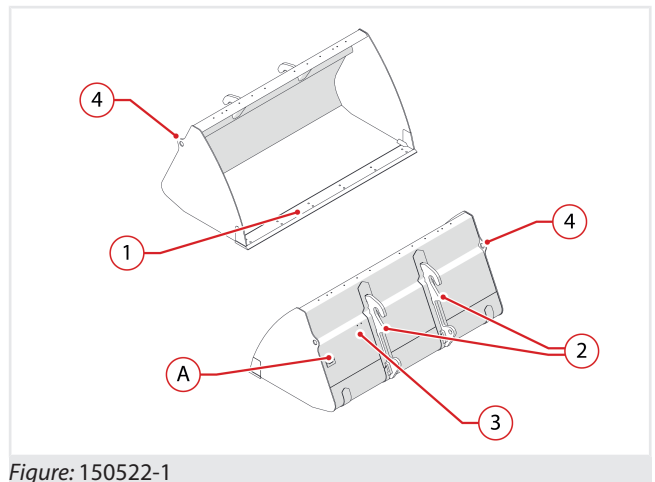

Figure: 150522-1

11.7.2 - Buckets description

All the buckets (fig. 150522-1) consist of the following components:

1. Blade
2. Hooks for plate connection
3. Tilt indicator
4. Hooks for lifting

11.7.3 - Buckets safety stickers

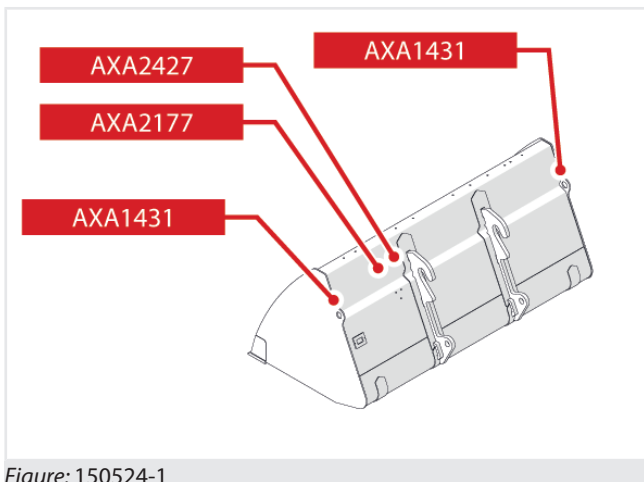

Figure: 150524-1

Safety stickers on buckets (fig. 150524-1):

- AXA2427 – Keep the safety distance from the equipment
- AXA2177 – Read the use and maintenance manual.
- AXA1431 – Lifting hook

11.7.4 - Bucket use



WARNING

Before starting to use the equipment, inspect and test it as described in the section “Equipment pre-use check”.

It is absolutely forbidden to use the forks or any type of equipment, without securing it to the attachment holding plate with the appropriate safety plugs.



DANGER

Before each use, check the wear status of the equipment, they could be worn out and not hold the load to be handled creating a dangerous situation.

Before starting to use the equipment, refer to the chapters:

- a) "Safety regulations"
- b) "Buckets Safe Working Procedures [▶ 166]"
- c) "Equipment pre-use checks [▶ 144]"



ATTENTION

Set the appropriate working mode of the vehicle during the bucket use. If this is not done properly, the anti-tipping device could start up and the movements will consequently stop during the bucket excavation or the loading.

To use buckets with Pegasus model vehicles, it is necessary to select the equipment on the anti-tipping device (fig. 171070-1). For the load charts of the Pegasus vehicle when using the bucket, refer to the fork diagram. Extending the boom beyond the letter "A", the loads are halved with respect to those shown on the fork diagram.



To use the buckets it is sufficient to move the plates tilting controls.

Moving the joystick to the left, the tip of the bucket will move up; moving the joystick to the right, the tip of the bucket will move down.

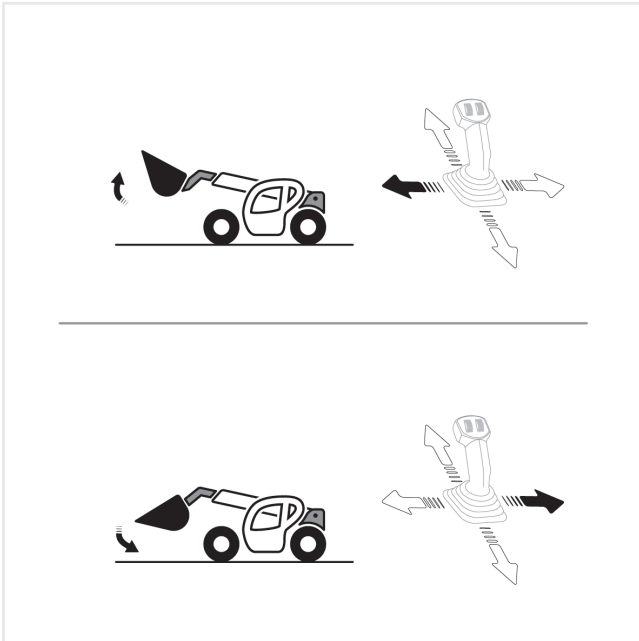

Figure: 150630-1



WARNING

Given the large size of the buckets, for some movements it will be necessary to remove the boom to prevent contact of the bucket with other parts of the vehicle. It is advisable to operate with the minimum possible extension of the boom.

11.7.5 - Fixed tilt indicator use

In the left part of the bucket there is the fixed tilt indicator (fig. 161030-1), this tool allows to know the angle of the bucket during use.

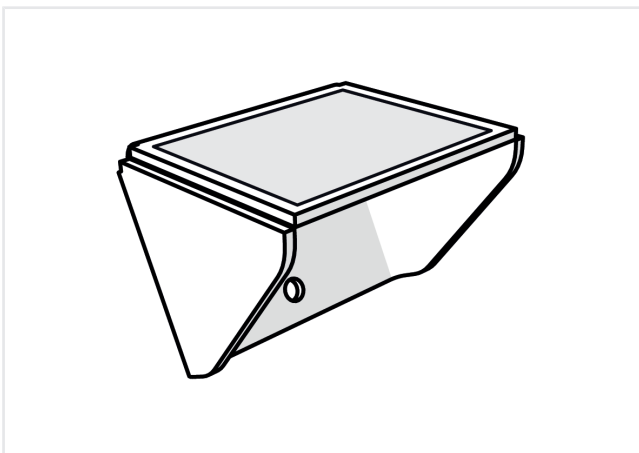

Figure: 161030-1

The bucket position can be determined based on the face shown by the fixed tilt indicator:

- **Upper visible face:** the bucket blade is turned upward
- **Face parallel to the ground:** the bucket is aligned to the ground

- **Lower visible face:** the bucket blade is turned downward

During the bucket loading phase, to obtain the maximum efficiency of the bucket it is appropriate to use the bucket aligned to the ground.

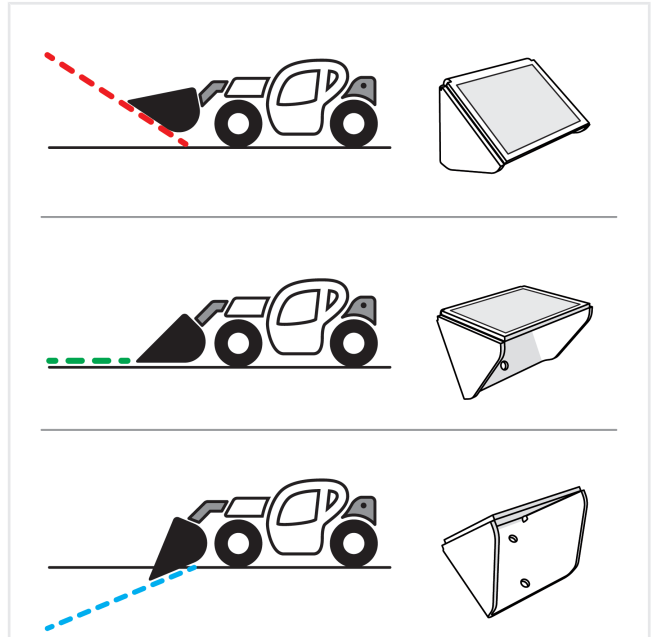

Figure: 161030-2

11.7.6 - Movable tilt indicator use *



NOTE

The movable tilt indicator is an optional accessory.

In the left part of the bucket there is the movable tilt indicator (fig. 161031-1), this tool allows to know the angle of the bucket during use.

It is composed of a pendulum "1" and by two indicators "2".

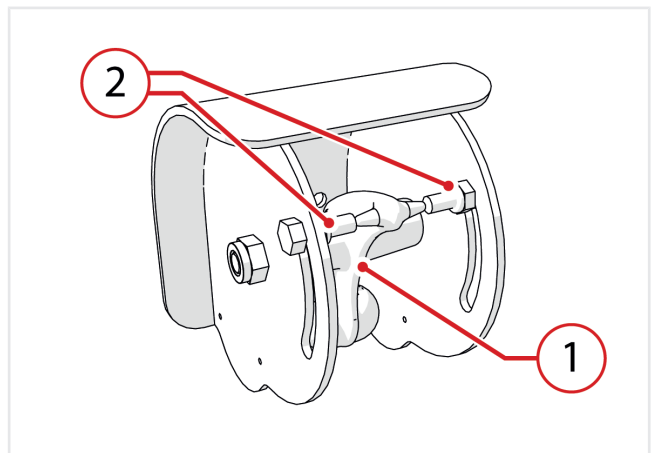

Figure: 161031-1

The bucket position is determined according to the position of the pendulum "1" compared to the indicators "2":

- **Pendulum above the indicators:** the bucket blade is turned upward
- **Pendulum at indicators level:** the bucket is aligned to the ground
- **Pendulum below the indicators:** the bucket blade is turned downward

During the bucket loading phase, to obtain the maximum efficiency of the bucket it is appropriate to use the bucket aligned to the ground.

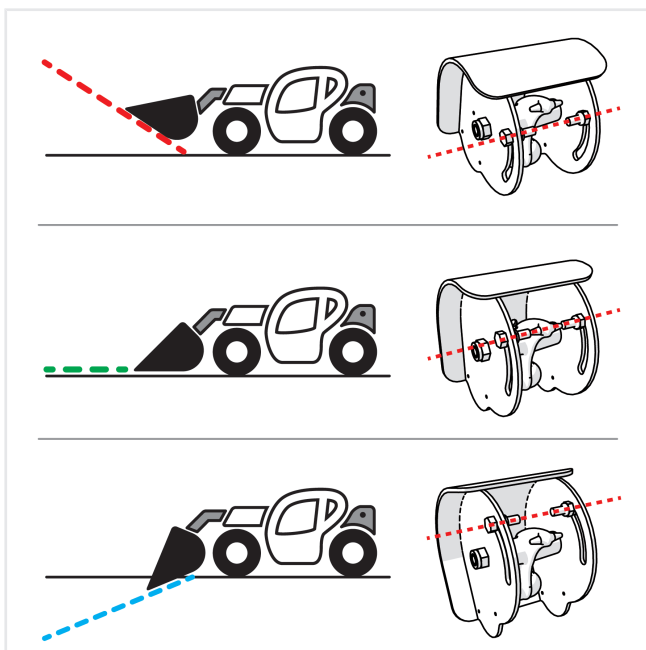

Figure: 161031-2

- Check the dimensions and characteristics of the work area and complete visibility of the load and of the surrounding area. Otherwise use a person on the ground assigned for signaling.

11.7.7.2 - Danger zones

The danger zones of the vehicle can be identified in the work area of the vehicle and of the bucket.

This area varies in size depending on:

- Load characteristics and size
- Load lifting height

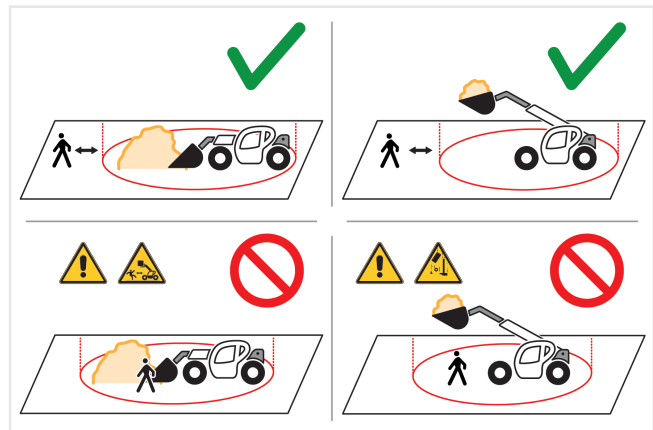

Figure: 150631-1



DANGER

Keep away from the vehicle during operation and from the aggregates to be moved, or from the excavation.

11.7.7 - Buckets Safe Working Procedures



DANGER

Do not change the structure of the equipment.



DANGER

Do not use the equipment for lifting persons, animals or things other than those specified.

11.7.7.1 - Checks before lifting

Before starting the operations, perform these checks and inspections to ensure greater safety for operators.

- Positioning of the vehicle and ground conditions.

11.7.7.3 - Bucket load

It is strictly forbidden to push or stack inert material with extended boom. It can cause serious damage to the vehicle.

It is strictly forbidden to push or stack material using the boom extension. It can cause serious damage to the vehicle.

It is strictly forbidden to make leveling or digging operations in reverse. It can cause serious damage to the vehicle.

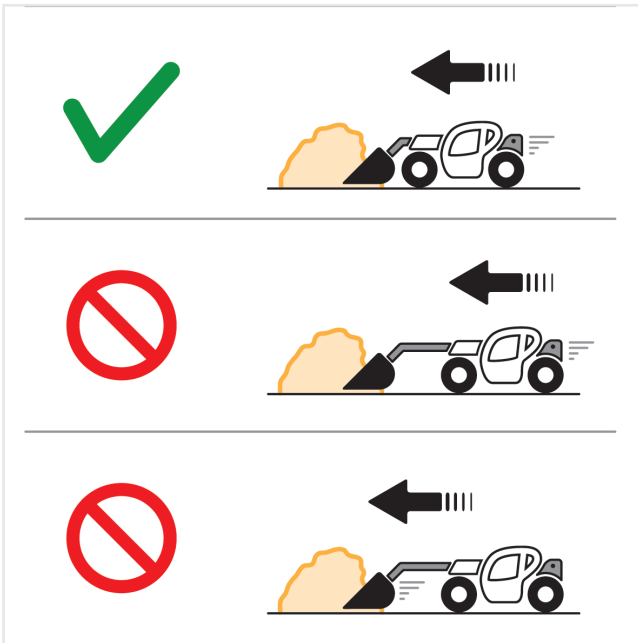

Figure: 150632-1

It is strictly forbidden to push or stack material with the vertical bucket planted in the ground.

11.7.7.4 - Bucket unloading



WARNING

It is strictly forbidden to repeatedly beat the swinging cylinder at closing limit switch to detach material attached to the bucket.

It can cause serious damage to the vehicle.



Figure: Vertical bucket use

11.7.7.5 - Carry a load with bucket

The correct vehicle movement position with the bucket equipment installed is:

- Bucket as close as possible to the ground
- Boom retracted as much as possible

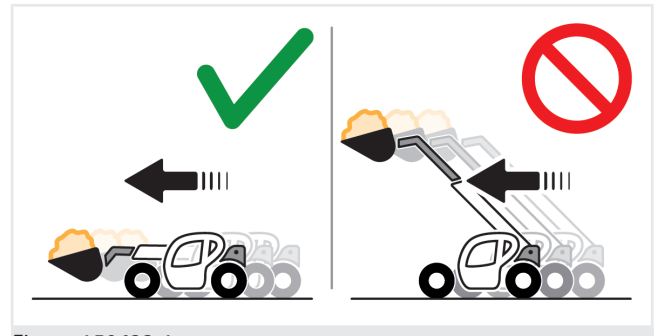

Figure: 150633-1



WARNING

It is advisable to keep the bucket at a height sufficient to be able to avoid roughness of the terrain along the way.

11.8 - Equipment lifting



WARNING

Make sure that the lifting device is adequate for the weight of the equipment to be lifted and that each device used for lifting and every accessory used is CE marked.

Make sure that the ropes, chains, straps and hooks are in good condition and with capacity adequate to the weight of the equipment to be lifted.

The weight of the equipment is shown on a special riveted metal plate; check the overall dimensions for the maximum and minimum height values from the ground and the weight allowed.

Position the hooks into the holes for the lifting locates at the top, at the center of gravity of the equipment.



DANGER

It is absolutely forbidden to transport the vehicle with the equipment still installed on it.

11.9 - Equipment transport



WARNING

Make sure that the capacity of the means of transport is adequate for the weight of the equipment to carry.

When loading or unloading an equipment from a means of transport, there is always the danger of vehicle overturning.

Use a truck or a trailer suitable for transport of the equipment.

When transporting the equipment it is advised to use a support platform for easier handling.

Then fasten the equipment with appropriate slinging systems, check that they are in good condition and appropriate for the weight and dimensions of the equipment.



DANGER

It is absolutely forbidden to transport the vehicle with the equipment still installed on it.

For details on the procedures to be followed during transport of the vehicle, refer to the Use and Maintenance Manual of the vehicle on which the equipment will be installed.

12.1 - Emergency procedure list

Emergency procedure	Additional information
Emergency procedure	7.10.4.1 Manually disable off the 2-gear hydrostatic transmission
	7.10.9.1 Deactivating the internal parking brake manually
	12.2 Vehicle towing
	12.2.1 Vehicle towing with electrical panel on
	12.3 Man basket recovery in case of failure for fixed vehicles
	12.3.1 Man basket recovery from cab
	14.4.6 Start up with auxiliary batteries
	14.4.6.1 Cable connection and engine start-up
	14.4.6.2 Cables removal

12.2 - Vehicle towing



DANGER

The vehicle towing is a delicate operation and the risks to the operator are high. The manufacturer's warranty is not applicable in case of incidents or accidents that occur during towing. If possible make repairs where the vehicle is located.

It is advisable that the towing operations are carried out by skilled personnel.

It is absolutely forbidden:

- Ever try to start the vehicle by pushing or towing.
- To tow the vehicle on public roads and for very long paths, if possible keep the yellow flashing light and the emergency lights in operation.
- To tow the vehicle on a slope.
- Stand between the towing vehicle and towed vehicle.



WARNING

With the engine off the steering wheel and brakes servo controls do not work. If it is not possible to keep the engine running while towing the vehicle take into account that the efforts to use the steering wheel will be much higher than normal.



ATTENTION

The vehicle towing can be made only in emergency conditions at a maximum speed of 4 km/h (2.5 mph) and for short distances up to 500 m (1640 ft).

To tow the vehicle over longer distances, contact *Dieci* service center.



ATTENTION

It is mandatory to tow the vehicle with a rigid towing bracket. The towing bracket must be designed for a tensile stress of 10 tonnes (22040 lb). Attach the towing bracket between towing vehicle and the vehicle in failure at the points prearranged for towing.



DANGER

Make sure that the weight of a towed vehicle not equipped with brakes never exceeds the weight of the vehicle that tows the vehicle. The distance required to stop the vehicle increases with the increase of the speed and of the load towed, in particular in the slope sections.

12.2.1 - Vehicle towing with electrical panel on

If it is necessary to tow the vehicle with the electrical panel in operation (for example, transmission failure) follow the following steps:

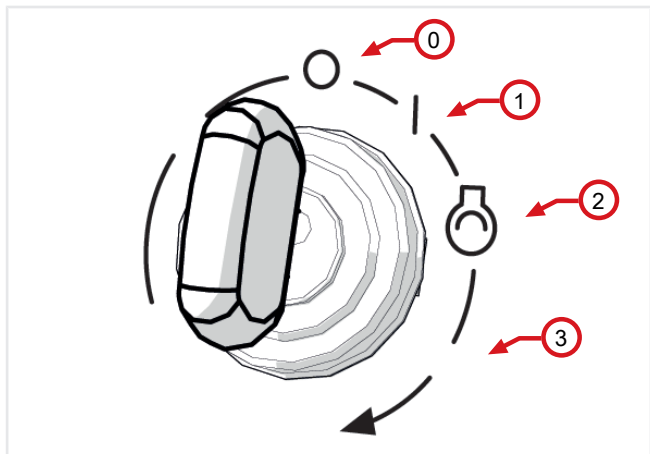

Figure: 150567-1

- Turn the vehicle off by turning the ignition key "0" (fig. 150567-1).

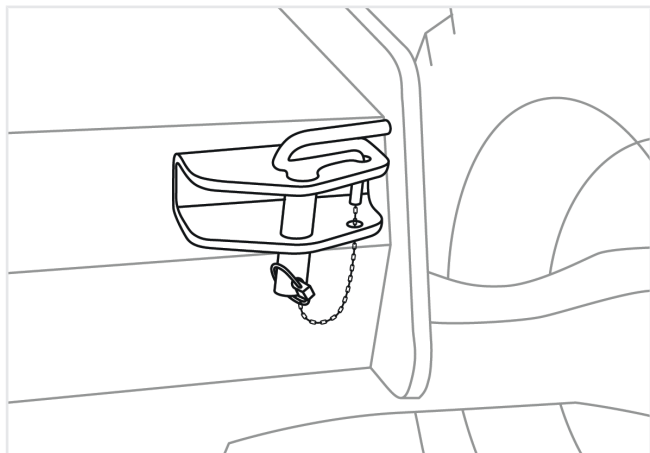

Figure: 150567-2

- Attach the towing bracket between towing vehicle and the vehicle in failure at the points prearranged for towing (fig. 150567-2).
- Make sure that the vehicle is in a stable configuration and lock the wheels with chocks to prevent accidental movement of the vehicle.
- Remove the lower protective casing by removing the screws with a wrench size **13**.

- Follow the steps described in the chapter "Manually disable the transmission".
- Switch on the electrical panel by turning the ignition key to position "1" (fig. 150567-1).
- Disengage the parking brake switch.
- Remove the wheels chock.
- During towing, remain seated in the driver's seat to prevent the parking brake from engaging automatically.

12.2.2 - Towing the vehicle with engine in failure

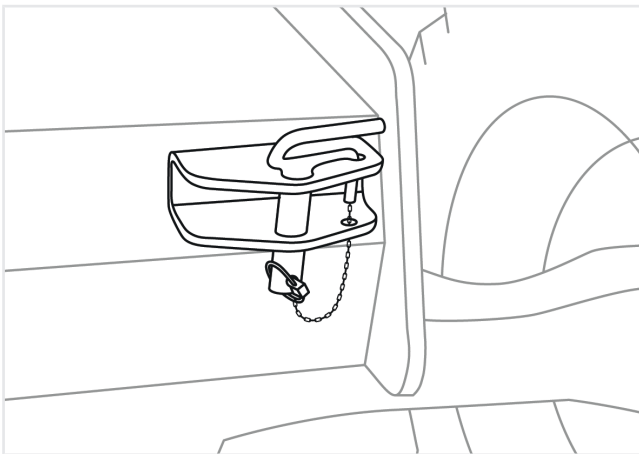

Figure: 150568-1

In case it is necessary to tow the vehicle with engine in failure, follow the following steps:

- Attach the towing bracket between towing vehicle and the vehicle in failure at the points prearranged for towing (fig. 150568-1).
- Make sure that the vehicle is in a stable configuration and lock the wheels with chocks to prevent accidental movement of the vehicle.
- Follow the steps in the section "Manually disable the parking brake on the vehicle front axle".
- Follow the steps described in the chapter "Manually disable the towing".



DANGER

With the engine off, the drive and parking brake are still active.

Towing the vehicle with active drive and brake can cause serious damage to the vehicle and create dangerous situations.

12.3 - Man basket recovery in case of failure for fixed vehicles

In the case of lack of motive force during use of the vehicle with man basket, which leads to the man basket locking, it is possible to operate with the manual system to return the boom and the operators on the ground in safe conditions. In order to carry out this emergency operation use the appropriate emergency pump.



DANGER

Under the emergency pump use conditions the anti-tipping systems are off. It is compulsory to refer to the load charts (found in the notebook in the cab and on the Use and Maintenance Manual) before performing any operation through the levers of the distributor. In this way it is possible, using the inclinometer and the letters on the boom, to know the exact location of the basket and of the work area within which it can operate. During the basket recovery there must not be no aggravating movements for the stability of the vehicle as there is a risk of tipping.



WARNING

Two qualified and experienced operators, authorized by the security officer, are required to complete the retraction operation.



DANGER

Do not ever try to get out of the man basket using makeshift equipment or using systems that expose to personal risk.

12.3.1 - Man basket recovery from cab



ATTENTION

This procedure is valid if the vehicle is operating correctly but for an illness or other causes, the operator on the basket is unable to return to the ground.

If it becomes necessary to recover the basket from the ground with the vehicle with engine in failure, refer to the chapter: "Man basket recovery in case of engine failure".



NOTE

To perform the man basket recovery procedure from the cab it is necessary to be in possession of the Recovery key.

The basket controls bypass function is performed by a key to give the possibility to the Safety Officer to extract the key to prevent deactivating the anti-tipping system during normal working conditions.



DANGER



Danger of tipping

The Recovery Key must be used only if all of the following conditions occur:

- a) By skilled and properly trained personnel
- b) For short periods of time
- c) If it is not possible to bring the basket to the ground through the basket controls.

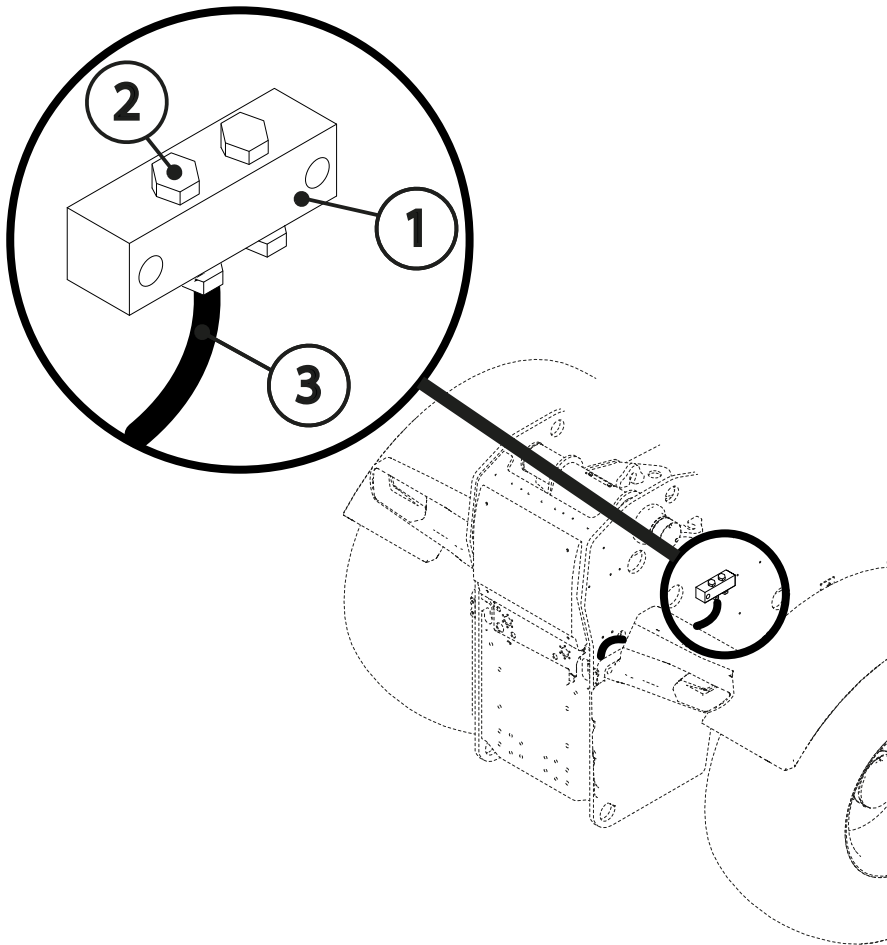

Figure: 160771-1

To carry out the basket recovery from the cab, perform the following procedure.

- Sit in the driver's seat and turn on the vehicle.
- Turn the Recovery key "1" to activate the controls in the cab.
- Keep the Recovery key "1" turned and use the joystick to:
 - Fully retract the boom.
 - Lower the boom to the ground.
- After the recovery, return to the starting conditions.

The collector "1" is used to lift the telescopic boom in case of malfunctioning and/or emergency.



1 - In case of malfunctioning and/or emergency, connect an external pump to the port "2" on pipe "3" in order to lift the boom.

- The oil in the external tank must be of the same type as the hydraulic oil in the machine circuit and as clean as possible.

2 - Once the necessary steps have been taken and after the boom has been lowered, restore the oil level.



WARNING

Before performing any maintenance operations set the vehicle in the maintenance position.

Use appropriate personal protective equipment during the various checking and maintenance operation of the vehicle.



WARNING

It is prohibited to carry out maintenance on the vehicle if this chapter has not been carefully read and learned.

To learn about maintenance operations and time, refer to the Maintenance Log.

All maintenance operations must be recorded on the appropriate Maintenance Log.

14.1 - Maintenance warnings

This vehicle has been designed and built to provide maximum performance, savings and facilitate its operation in various working conditions. Before delivery, the vehicle and the equipment were tested both by the Manufacturer and by the Dealer to ensure their maximum condition. In order to preserve these conditions and to ensure trouble free operation, it is important to perform routine maintenance, as specified in this Manual at a **DIECI** dealer at the frequency required.

This section of the Manual provides all the maintenance prescriptions necessary for maintaining the **DIECI** vehicle in perfect working condition.

It is recommended that all services must be carried out as part of the assistance program recommended by **DIECI**. Remember that the owner and/or user is responsible of keeping the vehicle and equipment in safe operating condition and able to operate.

It should be noted, also, that proper maintenance of vehicle and equipment not only improves reliability, but preserves its value over time.



ATTENTION

Maintenance or repairs not covered in this chapter and in the rest of the manual should be performed only by **DIECI Dealers.**

It is mandatory to have read and learned the "Safety" chapter before reading the "Maintenance" chapter.



WARNING

When operating in corrosive environments it is important to intervene with appropriate maintenance methods and timing in order to prevent excessive wear of the vehicle.



ATTENTION

Use appropriate personal protective equipment during the various checking and maintenance operations of the vehicle.



WARNING

In case of malfunction do not use the vehicle until it has been repaired.

14.1.1 - Avoid accidents during maintenance

- Always clean and tidy the workplace in order to carry out every operation safely.
- Do not leave tools or other instruments scattered in a disorderly manner in the workplace.
- Clean grease traces, oil or other substances that could cause you to slip.
- For the workplace safety put rags soaked with grease and/or other flammable materials in a secure container.
- Use only tools appropriate for the task and make sure to use them in the right way. The use of damaged, poor quality, faulty, makeshift tools or not suitable for use may cause serious injury.
- Do not hit the vehicle and the equipment or their parts with a hammer or any other instrument, as projected fragments could cause injury.
- If inspection or maintenance is carried out on vehicles or equipment which are still covered with mud, oil, etc., operators risk sliding or falling

and the visual analysis of components is made more difficult. Thoroughly clean the vehicle or equipment before every operation.

- Make sure about the maintenance procedures before starting the work.
- Keep the work area clean and dry.
- Replace worn or faulty components.
- Eliminate accumulations of grease oil and debris.
- The knurled metal sheets (bulb plates) and the cab floor are the only parts of the vehicle that can be stepped on. Use a ladder (suitable for the intended purpose) for maintenance of parts that cannot be reached from the ground.



DANGER

Do not carry out any maintenance operation with running engine or moving vehicle.

Should maintenance need to be performed with the engine running, ask at least two workers for help and observe the following instructions:

- One worker must always be seated in the driver's seat, ready to switch off the engine at any time.
- All workers must remain in contact with one another.
- Take care not to remain entrapped in components during the execution of operations performed on the fan, fan belt or other rotating parts.
- Do not touch levers or control pedals. Should a lever or pedal need to be moved, always warn operators first so they can move out of the dangerous area.
- Do allow instruments or other objects to fall into the vehicle rotating parts, as these parts may break and be projected out.
- The vehicle must be outdoors when the engine is running. The vehicle can be kept in a closed area only if it is properly ventilated and the vehicle is equipped with specific purifiers.



WARNING

In the case of operations to be performed by holding the boom raised, install the safety rod on the boom shaft.

If you need to perform repair or maintenance work under the vehicle, firmly support the movable parts with blocks and supports that are solid enough to support the weight.

- Store attachments removed from the vehicle in a safe place where they do not risk falling. Take precautions to prevent unauthorized persons from approaching the storage area.



DANGER

Do not rest metal parts on the battery.



DANGER

Danger of entanglement.

Damage may be caused by entanglement in moving parts. To prevent accidents it is compulsory to wear proper safety equipment for maintenance.



DANGER

Exhaust gas danger

Exhaust engine gases are toxic and can damage your health.

The vehicle must be outdoors when the engine is running.

The vehicle can be kept in a closed area only if it is properly ventilated and the vehicle is equipped with specific purifiers.



DANGER

Pressurized liquids danger

After operation, the engine cooling liquid is hot and under pressure. Contact with hot water and/or steam may cause serious burns.

- Do not attempt to loosen connections, pipes or hydraulic components when circuits are under pressure.
- Avoid possible injury caused by hot water jets.
- Do not remove the radiator cap until the engine has cooled down.
- Before removing the cap, release all of the pressure.
- Prevent burns caused by oil or other hot parts during inspection or discharge by allowing the oil and cap to cool down before beginning operation.
- Even after the oil has cooled down, slightly loosen the cover or cap before removing it to mitigate pressure inside.



DANGER

Burns danger

Attention to burns. Engine reduction gear oil and the hydraulic system, pipes, engine and other components heat up when the vehicle is used. Wait until all parts cool down before beginning maintenance or repair work.

- Fluids such as fuel or hydraulic oil under pressure can penetrate the skin and eyes causing serious injuries. Take care to avoid these risks when repairing or doing maintenance work on the vehicle.
- Discharge the pressure (using the hydraulic levers of the distributors) before disconnecting or repairing pipes and hydraulic parts.



DANGER

When a hydraulic pipe needs to be disconnected, slowly loosen the fittings to discharge residual pressure.



DANGER

Pressurized liquids danger.

Hydraulic energy accumulators are mounted on the vehicle. Before intervening on them, make sure to discharge any internal pressure. Danger of high pressure oil splashes.

- Before restarting the engine, ensure that all fittings have been properly tightened.
- Use a piece of cardboard to check for any leaks; make sure your body is adequately protected against pressurized fluids.
- Any fluids that penetrate the skin must be removed surgically. Should there be an accident, seek medical attention immediately.



DANGER

Corrosive substances danger

Never touch air conditioning coolant.

- If it comes into contact with eyes, air conditioning coolant may cause blindness; it may cause freezing if it comes into contact with skin.
- When cleaning with compressed air, serious injury may be caused by flying particles.
- Always wear protective goggles, a dust mask, gloves and other protective equipment.



WARNING

Adjusting and/or dismantling balancing and safety valves can be dangerous.

One of the above-mentioned valves may be removed only when the concerned jack is at rest and the hydraulic circuit is not under pressure.

All other operations must be carried out by qualified, authorized personnel only.



NOTE

Only use lubricants suggested by DIECI; never utilize used lubricants.

14.1.2 - Personal protective equipment for maintenance



WARNING

Always use the personal protective equipment most suitable to the checking or maintenance operation to be performed.

Icon	Description
	Wear protective goggles <ul style="list-style-type: none"> • Wear protective glasses in case of operations involving the use of compressed air.
	Wear safety shoes
	Wear protective gloves <ul style="list-style-type: none"> • Wear nitrile gloves in case of operations with grease, hydraulic oil or fuel.
	Wear protective clothing
	Wear a protective mask

- Reactivate the battery isolation switch.

14.4 - Battery



DANGER

To avoid the risk of explosion of the batteries:

- Keep sparks, free flames and cigarettes away from the top of the batteries because the gases that they can produce are highly flammable.
- Do not charge damaged batteries.
- Do not charge a hot battery.



DANGER



Batteries contain highly polluting substances that must not be dispersed in the environment.

Dead, old, damaged, batteries etc. must be properly disposed of.



DANGER

The battery contains sulfuric acid electrolyte which is a corrosive substance and must be treated with caution because it can cause poisoning and severe burns.

Keep out of the reach of children.

Avoid contact with skin and eyes.



ATTENTION

Wear protective clothing, gloves and safety glasses. In case of contact with eyes or skin, rinse immediately with plenty of water and seek medical attention. If swallowed, contact a doctor immediately.

- Do not overturn or tilt the battery as acid could come out.
- Charge the battery in a well ventilated area and always disconnect the power before removing the clamps.
- To check the charge status always use a voltmeter or a densimeter. If it is necessary to check the electrolyte level, use a flashlight, never a flame.
- Never place a metal object between the clamps to check the battery charge.

- Do not generate sparks with the cable clamps while charging the battery or starting the engine of the vehicle with an auxiliary battery.
- Check that the vent caps or covers are fitted correctly and firmly.
- Clean the top of the battery, check that the clamps are tight and cover them with a thin layer of petroleum jelly.
- In case of frozen battery this should be stored in a warm place to defrost. Do not use and do not recharge it: risk of explosion.
- In normal conditions the battery is kept charged by the alternator of the vehicle. If this becomes completely exhausted due to prolonged disuse or because at the end of its life the alternator loses its capacity to "regenerate". The battery must be replaced and recharged using a special battery charger tool.



WARNING

Before performing any maintenance on the vehicle, disconnect the power supply to the electric circuit of the vehicle by pressing the battery isolation switch.

14.4.1 - Low maintenance batteries

The low-maintenance batteries have been studied to avoid maintenance interventions in ordinary and normal use of the battery. In case of discharge check the electrolyte level. For technical specifications contact the supplier or the manufacturer.

14.4.2 - "Zero" maintenance batteries

They are batteries that do not allow maintenance intervention.

When the battery is discharged it must be replaced. For technical specifications contact the supplier or the manufacturer.



DANGER

Do not carry out maintenance or recovery operations on "zero" maintenance batteries.

14.4.3 - Battery: Instructions for recharging

- A battery is fully charged if at constant temperature the density of the electrolyte and the measured voltage at the poles does not increase within 2 hours.

- Each recharge will be good as good are the general conditions of the battery. This means that an old battery, after charging, will not have the same life and efficiency of a new battery.
- The simplest charging method is to charge at constant power.
- At the end of the charging, the battery charger voltage increases and creates gasification. It is recommended to use simple battery chargers with minimum current control and timer.
- If the battery has a low electrolyte level restore it to the minimum level (just above the plates limit) then charge them. After the charging is completed, fill to the maximum level (to prevent leakage).
- Overcharging must be avoided because:
 - It is a loss of energy which causes the dissociation of water.
 - It produces loss of active mass for the electrodes deterioration
 - It creates a risk of explosion.
- If sulfated batteries are recharged without voltage limitation, they will boil and warm up with a risk of explosion.
- For old batteries (in most cases sulfated) charge with great caution. Even with 13.8 Volts there is the possibility of a temperature increase.

Follow these instructions to recharge the battery:

1. Disconnect the cables of the vehicle from the battery to protect the electrical system of the vehicle.
2. Place the battery at a safe distance from the vehicle.
3. If possible, remove the caps.
4. Check the electrolyte level, if possible.
5. Clean the poles.
6. Make sure the room is sufficiently ventilated.
7. Limit the charging current to a maximum of 1/10 of the battery capacity (Ah).
8. Connect the battery to the charger.
9. Connect the charger to the mains.
10. Turn on the battery charger.
11. The battery temperature must not exceed 55°C.
12. After finishing switch off the battery charger.
13. Disconnect the battery charger from the mains.
14. Disconnect the battery from the charger.
15. Check the electrolyte level, if possible.
16. Refit the caps.

14.4.4 - Electrical battery isolator



WARNING

Use this switch only when the engine is stopped.

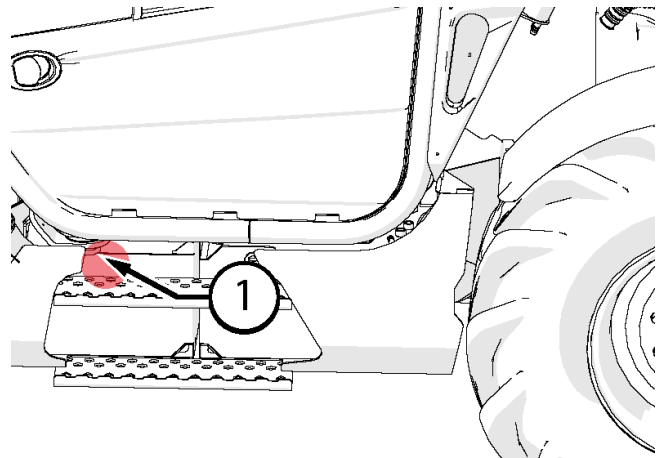

Figure: 160901-1

The battery isolation switch "1" (160901-1) allows the operator to isolate the battery from the electrical circuit in case of emergency or during maintenance operations.

To isolate the battery:

- Turn off the engine.
- Press button "1" to disconnect the battery.



DANGER

The warning light next to the battery isolation switch indicates that the engine control unit is still powered for about 500 seconds; it is forbidden to carry out maintenance work, such as welding or other operations potentially dangerous for the vehicle electronics.

The electric battery isolator switch is located above the last access step to the cab.

14.4.5 - Battery: Replacement

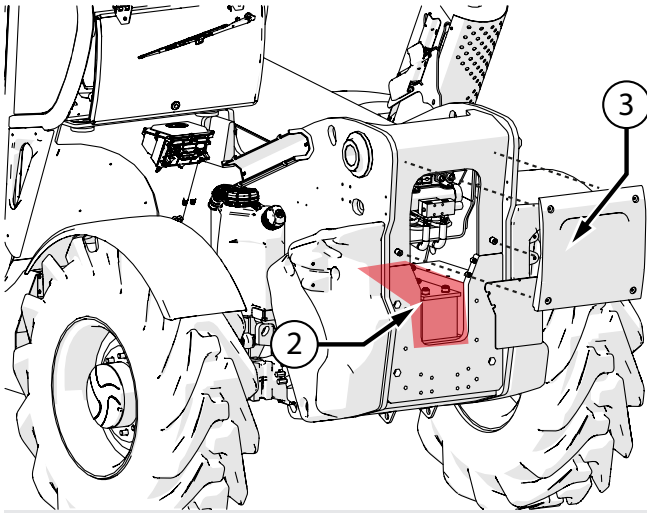

Figure: 150732-1

The vehicle is equipped with a battery located on the rear central part of the chassis "2" (fig. 150732-1). To reach the battery remove the protection housing "3".

Before removing the battery disconnect it from the electrical circuit through the appropriate battery isolation switch, following the instructions given in the relevant chapter.

To remove the battery:

- Place the vehicle in the service position as described in the "Setting the vehicle for maintenance" section.
- To access the battery it is necessary to remove the protection guards.
- Disconnect the NEGATIVE cable (black) from the battery.
- Disconnect the POSITIVE cable (red) from the battery.
- Remove the battery from the vehicle.
- Place the new battery.
- Connect the POSITIVE (red) cable to the battery.
- Connect the NEGATIVE (black) cable to the battery.
- Reactivate the battery isolation switch.
- Close the engine hood.

14.4.6 - Start up with auxiliary batteries



WARNING

Start-up with auxiliary batteries is an operation that requires two properly trained and qualified operators.

An error in executing the operations can cause serious damage to the vehicle, to property and people.

- When starting the engine using another vehicle, connect the accumulators in parallel. When connecting the cables, avoid contact between the positive cable "+" and the negative cable "-".
- Wear the necessary personal protective equipment before starting the operation.
- Take care to avoid contact between the vehicle to be started and the vehicle that must supply power to prevent sparks and explosions of hydrogen produced by the accumulators. The accumulator explosion causes serious damage and injury.
- Make sure not to exchange the ignition cables and first connect the earth cable (-) and then the positive cable (+).
- Be very careful when removing the ignition cables; to ensure that the cables disconnected from the accumulator do not touch other parts of the vehicle to avoid explosions caused by hydrogen.
- Cables and grippers must be proportional to the current load to be transferred. The accumulator to be used for the start-up must have a capacity greater than or at least equal to that of the standard accumulator installed.
- Check the cables and grippers for corrosion or damage. Make sure the grippers are tightly gripping the terminals.
- Be very careful during the different operations: direct or indirect contact with live parts can result in injury and sometimes even in death.
- When starting the engine, the operator must be in the driver's seat so as to keep the vehicle under control.
- All these operations must be carried out by skilled and trained personnel.

14.4.6.1 - Cable connection and engine start-up

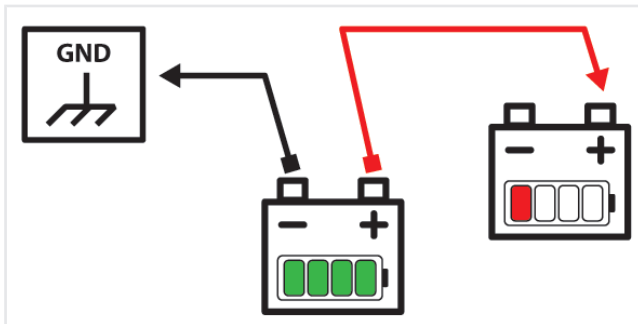

Figure: 150539-1

1. Make sure the ignition key is in position "O".
2. Connect the cable from the negative clamp "-" of the charged battery to the earth block of the vehicle to start-up.
3. Connect the positive terminals "+" of the two batteries to each other.
4. If a charged battery installed on a properly running vehicle is used, start the engine of the latter and run it at high rpm.
5. Start the engine of the failed vehicle.

14.4.6.2 - Cables removal

With the engine running remove the cables in reverse order of the connection.

1. Disconnect the positive cable "+" first from the battery used for starting and then from the low battery.
2. Disconnect the negative cable "-" from the earth of the running engine and therefore from the fully charged battery.

14.5 - Fuel



DANGER



Never add different types of fuel such as petrol or alcohol to diesel.



It is forbidden to refuel while the engine is running.

It is forbidden to smoke when refueling.



DANGER



Inhale diesel fumes for the least time possible as they are dangerous carcinogens for your health.

Before handling fuel and filling the tank, comply with the following regulations:

- Clean the area around the fuel cap. Refill the fuel tank at the end of every day to reduce condensation when the vehicle is at rest.
- Water and sediments must be removed before they reach the engine.
- Do not use antifreeze to remove water from diesel fuel.
- Do not rely on a filter to remove water from diesel fuel.
- Never leave the tank without a cap and always lock it. Should you lose the original cap, replace it with an original spare. Not just any cap is suitable.
- Keep the fuel pump gun under control while filling the tank.
- Do not inspect the tank with a flame.
- Do not fill up the tank completely. Leave room for expansion and immediately clean any spillage.
- In the event of fuel leaks due to breakage, stop the leak as quickly as possible, do not use the vehicle and contact DIECI customer service.

14.5.1 - Specifications for recommended fuel



NOTE

To achieve good performance, see the engine manual of the vehicle to know the best features.

14.5.2 - Cleaning and storing fuel

It is important for the fuel to be kept clean.

The advice provided below will help maintain fuel quality.

- Never use zinc-coated containers.
- Never clean the inside of containers or power supply system components with cloths that may leave deposits.
- The cistern capacity must allow intervals between refueling not to be too long. A capacity of 3000 liters is sufficient for an average sized company.
- The storage cistern must be covered and placed on a support that is high enough to allow the vehicle refueling by means of gravity. A large basin for collection must be placed under the cistern in case of fuel leakage. The cistern must have an opening large enough to allow someone to access it for cleaning purposes.

- The delivery tap must be larger at the bottom in order to trap any deposits; it must also be equipped with a removable filter. The cistern should be tilted 40 mm per meter towards the sedimentation drain plug.
- The fuel barrels must be covered when stored to prevent water infiltration. The barrels should be slightly tilted slightly, so that any water will run to the upper rim. The fuel barrels should not be stored for too long before being used.
- If the barrels are kept outside, their caps must be tightly closed to prevent water from seeping in.
- After refueling the storage cisterns or barrels, it is recommended to allow the fuel to set for at least two hours, thereby allowing any sediment of water and impurities to be deposited before the fuel is used.

14.5.3 - Refuelling

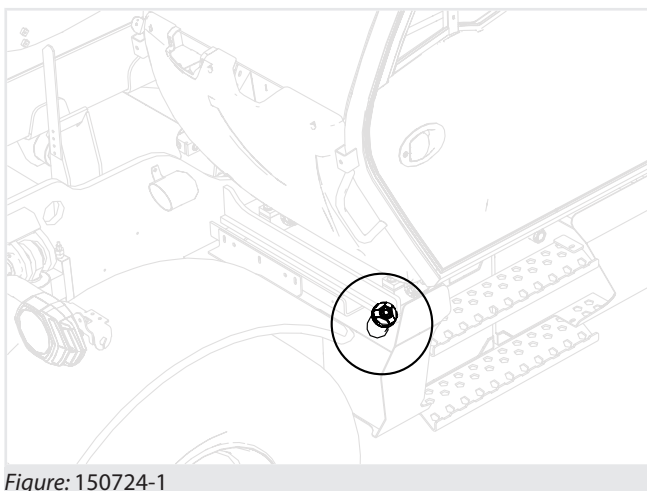

Figure: 150724-1

When refueling (fig. 150724-1) it is necessary to:

- Park the vehicle and turn off the engine
- Open the fuel cap
- Refuel
- Close the fuel cap

14.5.4 - Fuel tank: Cleaning

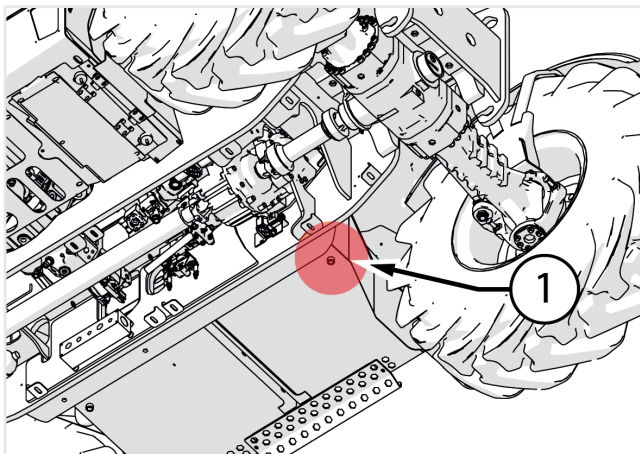

Figure: 150725-1

With the vehicle in the maintenance position:

- Place a suitable container under the fuel tank.
- Remove the plug from under the tank (fig. 150725-1) and drain the fuel to remove impurities present in the tank.
- Put back the cap and fill with clean fuel.

14.6 - Safety stickers: Inspection

- Check that all safety stickers are intact and in good condition.



NOTE

Refer to the chapter "Safety Stickers Cleaning" for cleaning the safety stickers.

14.7 - Lubrication

Lubricate the points shown in the figure until grease comes out and clean the lubricators from dirt or deposits.

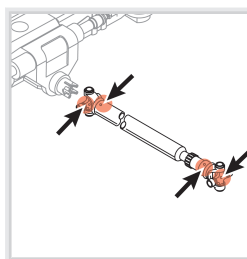

Drive shafts lubrication points.

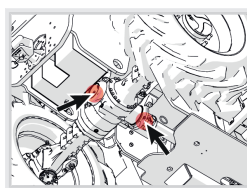

Swinging axle lubrication points.

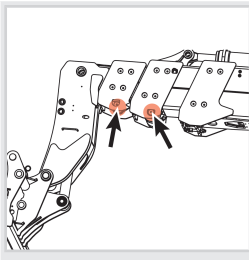

Boom with chains lubrication points.

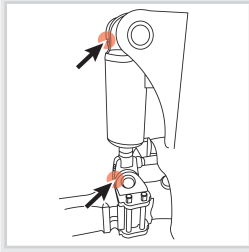

Levelling cylinder lubrication points.

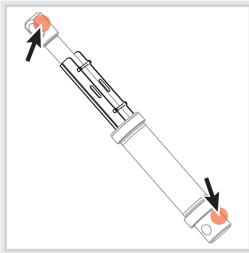

Lifting cylinder lubrication points.

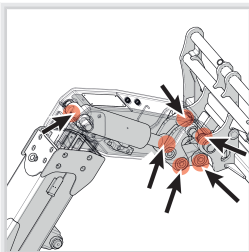

Counter lever and swing cylinder lubrication points.

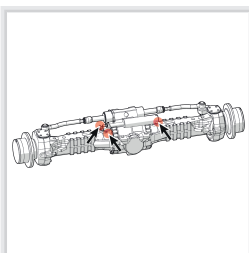

External parking brake cylinder lubrication points.

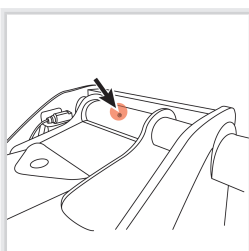

Boom-chassis pin lubrication points.

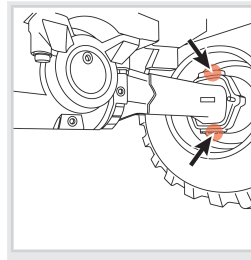

Wheels lubrication points.

14.7.1 - Automatic lubrication system



NOTE

The automatic lubrication system is an optional accessory.

14.7.1.1 - Controls

The following table describes the command and control devices for the centralized lubrication systems with pause - work timer and pause - sensor timer.

The devices on the Timer are highlighted in the figure.

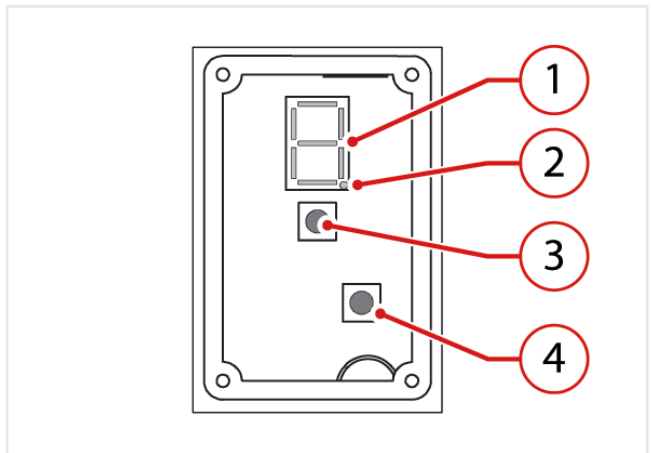

Figure: 180101-1

	Type	Description
1	Display	<ul style="list-style-type: none"> • During the time setting procedure it displays the parameters set. • During the normal operation of the system, the LEDs that make up the display light up alternately.
2	Display led	It lights up when the lubrication system is electrically powered.
3	TEST button	<p>It can be pressed applying a light pressure, on the writing "push", on the timer access cover.</p> <p>When pressed during the normal operation of the pump it starts the set working cycle, carrying out an operation test.</p>

Type	Description
	Once the work cycle is completed, the timer returns to automatic operation. When pressed during the timer programming, it is possible to scroll through the selections.
4 ENTER button	<ul style="list-style-type: none"> Pressed for 3 seconds starts the digital programming procedure. Pressed briefly during the programming phase, it allows to modify the P (pause) or L (work) values.

14.7.1.2 - Timer programming

The operations that must be performed for the digital programming of the control timer are summarized below.



NOTE

Remember that if the power supply is interrupted, the timer will save the internal data in a digital memory with virtually unlimited duration over time. When the power supply is restored, the timer reloads the previously saved data and resumes the time counting from the point where it was interrupted, and from the condition in which it was

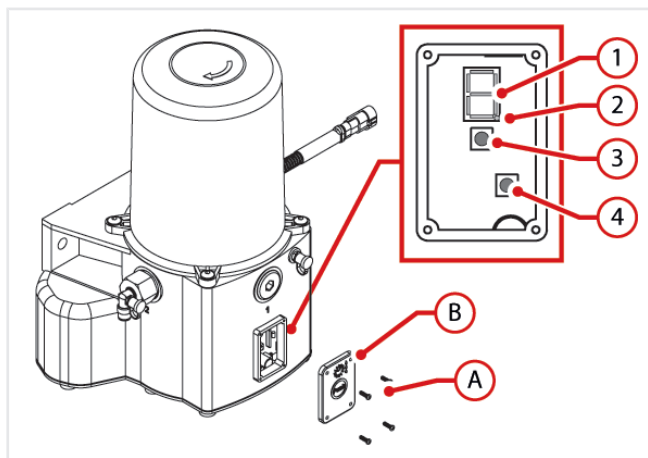

Figure: 180102-1

N	Operation	Effect
1	Loosen the fastening screws "A" and remove the access cover "B" to the timer	The Timer for digital programming is accessed.
2	Press and hold the ENTER button for 3 seconds	The display turns on and the letter P (Pause time) is displayed.

N	Operation	Effect
3	Briefly press the ENTER button	The display shows the value set for parameter P.
4	Pressing the TEST button	Every time the display is pressed, the digits or letters shown in the Pause time settings table are displayed sequentially.
5	Briefly press the ENTER button to confirm the setting chosen	The value shown on the display is stored as current value of parameter P and the display shows the letter P again.
6	Press the TEST button to switch between the P and L parameters display	The display shows the letter L (Work time). NOTE: remember that pressing the TEST button alternates the display of the letters P or L.
7	Briefly press the ENTER button	The display shows the value set for parameter L.
8	Pressing the TEST button	Each the display is pressed, the digits or letters shown in the Work time settings table are displayed sequentially.
9	Briefly press the ENTER button to confirm the setting chosen	The value shown on the display is stored as current value of parameter L and the display shows the letter L again.
10	Press and hold the ENTER button for 3 seconds	The display turns off and the timer is ready to work with the new parameters set.
11	Reassemble the timer access cover "B" and tighten the fastening screws "A"	The pump is ready to work.

The electric pump in the version with control timer is delivered to the customer with the following default settings:

Models	Pause time	Work time
Pegasus 45.30	Turret – 6 Carriage – 8	Turret – 6 Carriage – 3
Pegasus 50.21	Turret – 6 Carriage – 6	Turret – 3 Carriage – 6
Fixed	8	2

Display	Time
0	5 min
1	10 min
2	15 min
3	30 min
4	1 h
5	2 h
6	3 h
7	4 h
8	5 h
9	6 h
A	7 h
B	8 h
C	9 h
D	10 h
E	11 h
F	12 h

Table 5: PAUSE (P) times setting table

Display	Time
0	20 sec
1	40 sec
2	1 min
3	1.5 min
4	2 min
5	2.5 min
6	3 min
7	3.5 min
8	4 min
9	4.5 min
A	5 min
B	5.5 min
C	6 min
D	6.5 min
E	7 min
F	8 min

Table 6: WORK (W) times setting table

14.7.1.3 - Tank filling

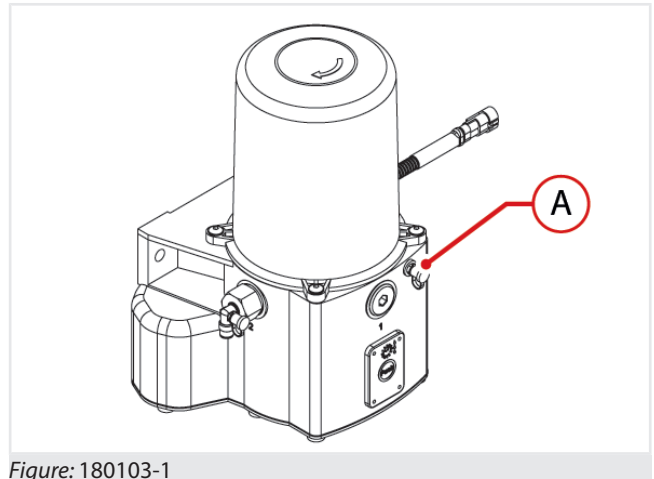

Figure: 180103-1

The pump tank is filled using the lubricator "A".

Remove the cap from the lubricator and, using the appropriate dispenser, fill the tank up to the maximum level (**MAX**) indicated by the adhesive strip attached to the tank.

For the characteristics of the lubricant to be used, refer to the following paragraph.

During the tank filling, the air contained in it is discharged to the outside through the appropriate vent. Make sure that the vent, placed at the rear of the tank, is not clogged.

14.7.1.4 - Lubricants

It must be remembered that the automatic greasing system is designed to work with lubricants having maximum NLGI 2 grade

- Use lubricants compatible with the NBR gasket
- The components of the systems that are supplied with lubricant in them are supplied with NLGI 2 grade lubricant

A comparison table related to the classification of NLGI (National Lubricating Grease Institute) and ASTM (American Society for Testing and Materials) lubricants, limited to the values for automatic greasing systems, is shown below.

Range description	NLGI grade	ASTM penetration at 25°C in 1/10 mm
Fluid greases	0	445 – 475
Semi-fluid greases	0	400 – 430
Semi-fluid greases	0	355 – 385
Soft grease	1	310 – 340
Medium grease	2	265 – 295

Table 7: Compatible lubricants table

For more information on the technical characteristics and safety measures to be taken, consult the Product Safety Data Sheet (Directive 93/112/EEC) concerning the type of lubricant chosen and supplied by the manufacturer.

14.7.1.5 - Operation check

Perform the following check after a long period of vehicle downtime:

- Check that the lubricant in the tank is above the minimum level.
- Disconnect one or more secondary pipes from the bearing points.
- Press the manual start button (TEST).
- Repeat the operation described in the previous step until the lubricant correctly reaches all the disconnected bearing points.
- Re-engage the piping to the bearing points.

In case the system does not work properly, consult the ANOMALIES chapter.

14.7.1.6 - Filter replacement

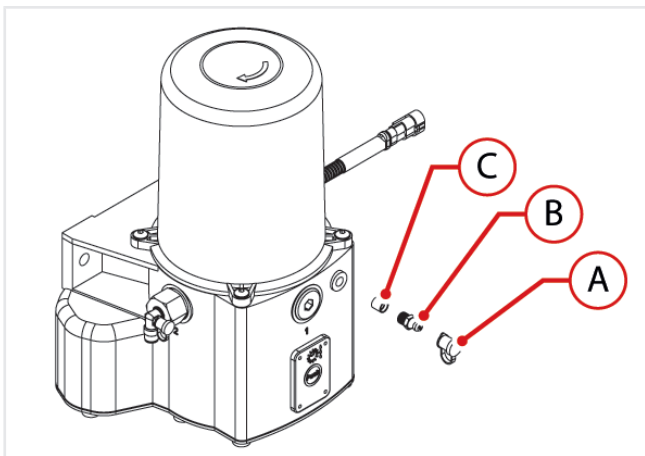

Figure: 170104-1

For maintenance of the tank filling filter, remove the plug "A", the lubricator "B" and the filter "C".

Check the condition of the filter and if necessary clean it using compressed air.

If it is still dirty after having carried out the cleaning operation, replace it.

Then, reassemble the filter "C", the lubricator "B" and the plug "A".

To tighten the lubricator "B", use a maximum torque of 6Nm.

14.7.1.7 - Operating anomalies

This chapter informs maintenance personnel about:

- the possible anomalies that may occur during the operation of the system;
- the reason that caused the failure to start or stop the system;
- possible remedies to be adopted.

No.	Anomaly	Code	Cause	Remedy to be taken
1	The pump motor does not work	1.01	Current is not supplied	Check the power supply system, checking the status of the fuse
		1.02	The electronic board does not work	Replace the electronic board
		1.03	The gear motor does not work	Replace the gear motor
2	The pump does not send lubricant	2.01	The tank is empty	Fill the tank with clean lubricant
		2.02	Air bubbles in the lubricant	Disconnect the primary pipe from the connection fitting to the pumping element. Operate the pump according to the manual operating cycle until lubricant completely free of air bubbles comes out from the fitting
		2.03	Use of unsuitable lubricant	Replace the lubricant with suitable lubricant
		2.04	Clogged pumping element suction	Remove the pumping element and clean the suction ducts
		2.05	The pumping element piston is worn out	Replace the pumping element
		2.06	The delivery valve of the pumping element is blocked	Replace the pumping element

No.	Anomaly	Code	Cause	Remedy to be taken
3	The pump works but lubricant does not arrive to the bearing points	3.01	Pipes disconnected	Check the condition of the pipes and the relative connections to the fittings. Replace worn pipes
		3.02	Progressive distributor blocked	Replace the distributor or clean it

No.	Anomaly	Code	Cause	Remedy to be taken
8	The pump starts the lubrication phase but it stops immediately	8.01	Defective engine or high output absorption	Allow to cool for a few minutes and then try again: if the problem persists, contact the Customer Service

Table 8: Table of anomalies

No.	Anomaly	Code	Cause	Remedy to be taken
4	The lubricant is distributed to the bearing points in irregular doses	4.01	The distributor is not correctly connected to the bearing points	Check the dosages with the system diagram
		4.02	Wrong pause time setting	
5	The display LED is not turned on.	5.01	The supply voltage is not correct	Check that the supply voltage is between 20V DC and 30V DC and then intervene on the supply circuit
6	Pressing the TEST button the engine does not operate	6.01	The engine is not correctly connected to the timer	Check the wiring that connects the electric motor to the timer and then restore the correct connection
		6.02	The engine does not work correctly	Check that the motor is not short-circuited or that it absorbs a current exceeding 7A. Replace the gear motor.
7	The display LEDs rotate but the motor does not work	7.01	Defective motor	Contact the Customer Service

14.8 - Preliminary maintenance operations

14.8.1 - Prepare the vehicle in the "Maintenance position"



WARNING

Before performing maintenance work on your vehicle, do the following:

- Park the vehicle on flat, even ground.
- Engage the parking brake.
- Lower and fully retract all mobile parts (booms, shovels, etc.).
- If the maintenance operation requires the mobile parts to remain up, apply the safety rod.
- Run the engine at a minimum for 60 seconds to cool it down.
- Release residual pressure from the hydraulic system.
- Switch off the key in the ignition switch.
- Remove the ignition key.
- Hang up a sign that indicates maintenance work is underway. This sign can be hung on the cab door and inside it on the controls.
- Set up barriers and spacers to prevent unauthorized personnel from approaching the vehicle.
- Disconnect the battery isolation switch.
- Allow the engine to cool down.

14.9 - Engine maintenance



NOTE

For the engine maintenance operations, refer to its manual.

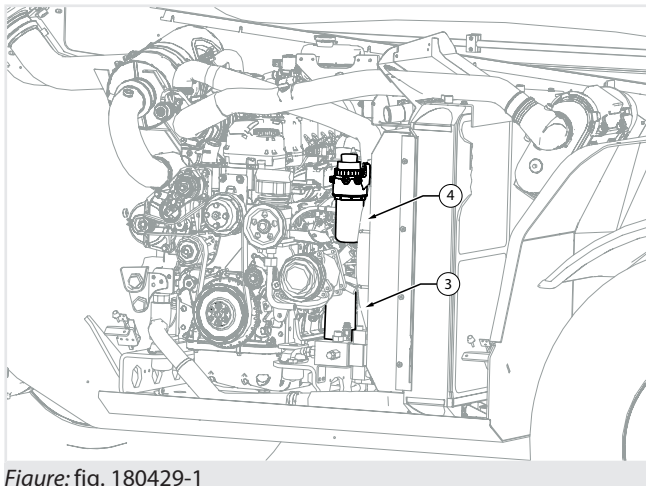
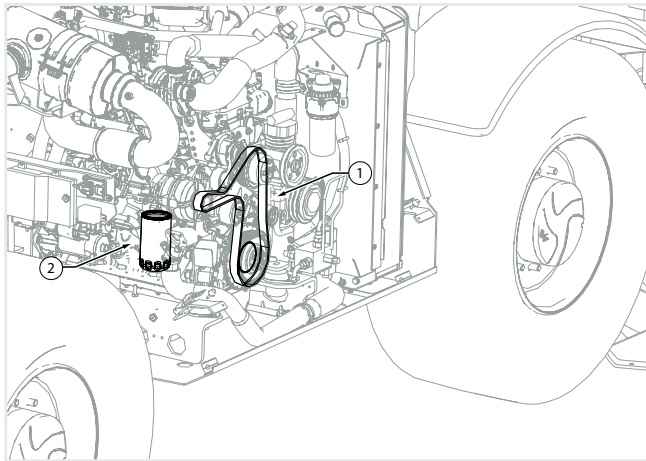

Figure: fig. 180429-1

14.9.1 - Belts: Check and adjustment

Check that the belt "1" (fig. 180429-1) does not have cuts, cracks or rubbing signs; when in doubt, install a new belt.

Make sure that the belt is properly fit on the pulleys and that the tensioner is working properly.

NOTE! If the belt does not appear in good condition, replace it with a new one.

14.9.2 - Fuel filter: Replacement

In the engine compartment there are the fuel pre-filter "4" (fig. 180429-1) and the fuel filter "3".

NOTE! Refer to the engine manual for the fuel filter replacement operations.

14.9.3 - Engine oil filter: Replacement

The engine oil filter "2" is present in the engine compartment (fig. 180429-1).

NOTE! Refer to the engine manual for the operations to replace the engine oil filter.

14.9.4 - Engine oil: Check and filling up

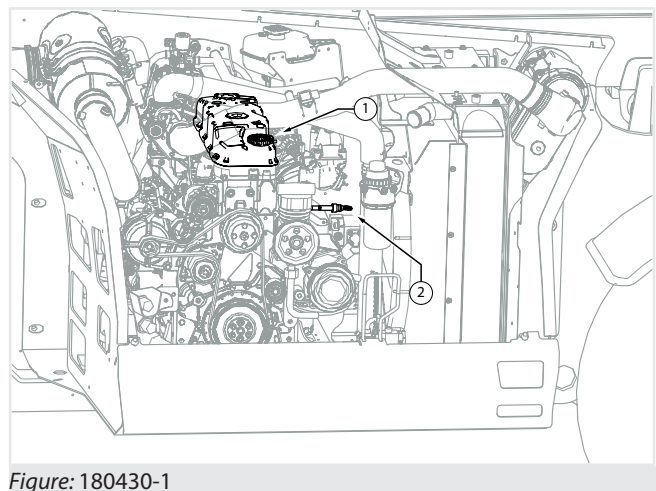

Figure: 180430-1

- Check the level with the vehicle on level ground and the engine turned off. Wait at least 5 minutes to allow the oil to settle into the sump.
- Pull out the dipstick "2" (fig. 180430-1), clean it and insert it back fully down.
- Pull out again the dipstick "2" and check that the oil level is between the "MIN" and "MAX" mark.
- Put back the dipstick and insert it fully down.
- If necessary, add oil from the cap on the engine "1".

For the amount and type of oil, refer to the engine manual.



WARNING

Do not fill beyond the "MAX" mark; if the amount is excessive, oil burns with production of smoke and possible damage to the DPF.

Never operate the engine with the oil level below the "MIN" mark.

14.10 - Air filter: Cartridges cleaning and replacement



ATTENTION

The inspection, cleaning and replacement must be carried out with the vehicle in the maintenance position.

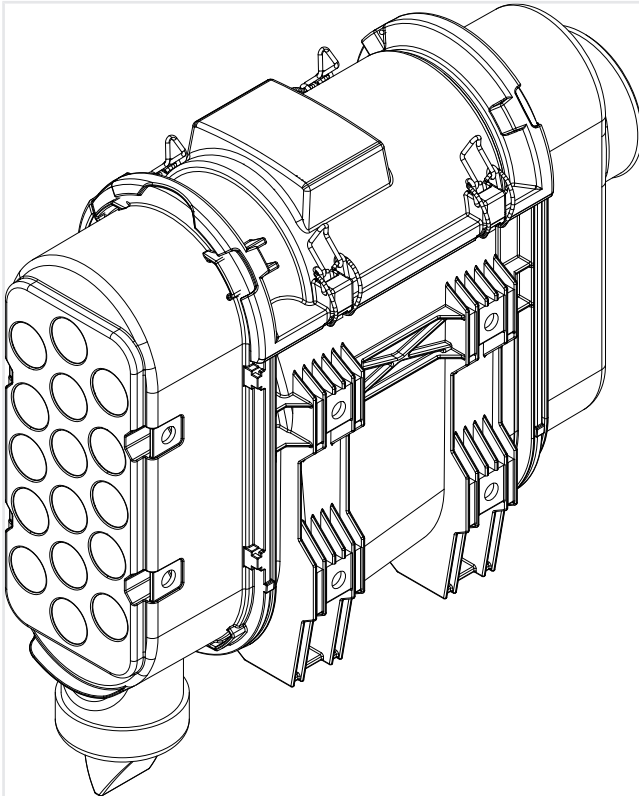

Figure: 150615-1

An air filter (fig. 150615-1) in bad conditions results in the reduction of power, excessive fuel consumption and reduced engine life.



150615-2

A clogged filter is signalled by the indicator light (fig.150615-2) located on the dashboard of the vehicle; after the clogging indication it is possible to continue operating for a period not longer than 10 hours. The maintenance must however be performed at the frequency required.



WARNING

When the clogging is indicated, it is possible to continue working for not more than one hour.

It is recommended to:

- Clean the filters only when the indicator light indicates clogging or at the frequency required. Unnecessary and too frequent cleaning exposes the elements to damage by handling that can allow dust and dirt to pass through the filtering stage and cause engine damage.
- In case the filter elements are in contact with liquids of any kind they must be replaced.
- Periodically check the intake sleeves, replace them immediately in case they are damaged or deteriorated.
- Periodically check the tightness of the bolts and clamps. Air must not be allowed to get into the engine circulation without having first gone through the filter.

For the complete efficiency of the filter it is recommended to operate with the filter complete with all its parts and components, assembled in the correct way.

Each deteriorated part must be replaced as soon as possible.



ATTENTION

For the complete efficiency of the filter it is recommended to operate with the filter complete with all its parts and components.

Each deteriorated part must be replaced as soon as possible.

It is absolutely forbidden to operate without the engine air filter.

The engine sucks air constantly during its use; dust particles entering in circulation may cause serious damage.

For proper cleaning of the filter it is necessary to:

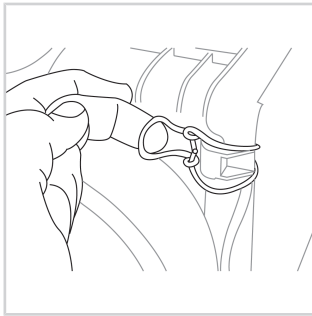

150615-3

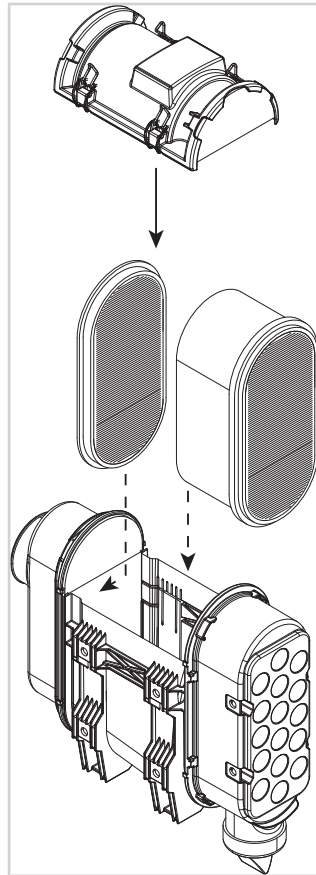

150615-4

- Prepare the vehicle in the maintenance position.
- Open and lock the hood.
- Open the filter cover (fig. 150615-3) pulling the locking levers located on the four corners.
- Lift the cover and remove the cartridges from inside the filter (fig. 150615-4).
- Use a wet lint-free cloth to clean the box and the cover.
- Clean or replace the filters. The filter cleaning is carried out with compressed air, up to **3 bar** (43.5 psi), at a distance of not less than **150 mm** (5.9 in), taking care not to damage the filtering element.
- Reassemble everything carrying out the same operations in reverse.

14.11 - Radiator maintenance

14.11.1 - Air recirculation grids and nets

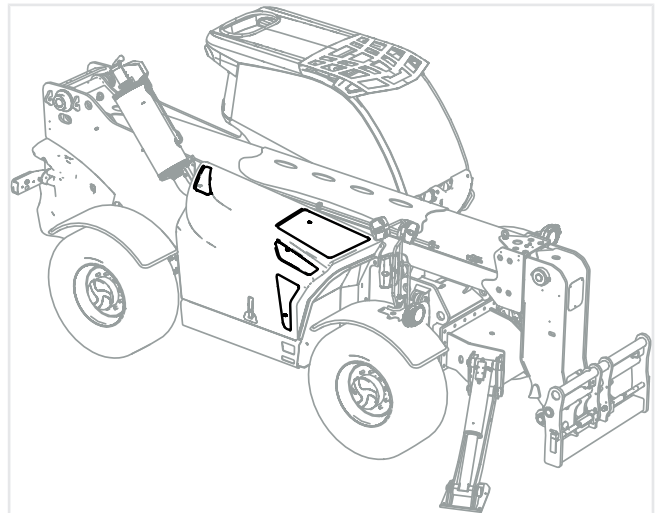

Figure: fig.180431-1

Check that the air recirculation grids and nets (fig. 180431-1) are clean and free from dirt:

For cleaning use a jet of air at low pressure from the inside to the outside of the vehicle.

14.11.2 - Radiator: Checking and cleaning

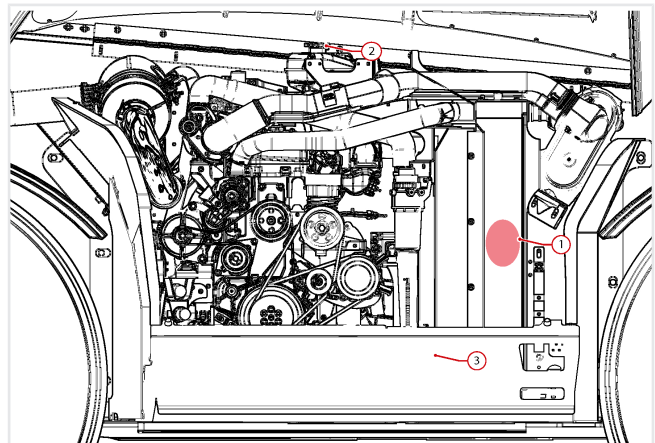

Figure: 180432-1

The oil and water radiator "1" (fig. 180432-1) involve the following steps:

Radiators check

- Check that the fins are not deformed; in that case straighten with caution.
- Check that the fins have not accumulated dirt and that they are not obstructed.

Radiators cleaning

- Prepare the vehicle in the maintenance position.

- Clean the radiator from dirt and impurities accumulated between the cooling fins. For cleaning use compressed air with pressure not exceeding 7 bar directed from the inside towards the outside.
- If necessary, apply a detergent solution and then remove it with a pressure washer.

14.11.3 - Radiator: Liquid filling up and replacement



DANGER

Do not remove the filling cap of the radiator when the system is hot, otherwise it could cause leakage of boiling coolant. Once the system has cooled, turn the filling cap to the first mark and wait until the pressure has completely exhausted before proceeding.

Danger of burns and injuries.



DANGER

The coolant can be toxic. Avoid contact with skin, eyes or clothing. Rinse thoroughly with water in case of contact with skin and eyes. Consult a doctor immediately.

If not reused, dispose of in accordance with local environmental regulations.

Filling up

- Prepare the vehicle in the maintenance position.
- Open the engine hood.
- Slowly unscrew the filling cap "2" (fig. 180432-1) anti-clockwise until it reaches the safety switch cover.
- Exhaust the residual pressure and steam.
- Add the coolant up to the level of 30 mm (1.2 in) below the cap.
- Put back the cap.
- Close the engine hood.

Coolant replacement

- Prepare the vehicle in the maintenance position.
- Open the engine hood.
- Remove the discharge sleeve "3" (fig. 180432-1) to drain water from the radiator.

- Remove the filling cap "1" to speed draining.
- Allow the cooling system to completely drain.
- Rinse the radiator with clean demineralised water introducing it from the filling cap "1" and making it flow out from the orifice of the sleeve "2". If necessary, add detergent.
- Check the condition of sleeves and their fittings, replace them if necessary.
- Once cleaning has been completed, refit the drain sleeve "2".
- Fill the cooling system from the filler cap "1" until the level is 30 mm (1.2 in) below the cap with the coolant previously prepared.
- Close the filler cap.
- Close the engine hood.
- Start the engine at idle speed for a few minutes.
- Make sure there are no leaks, check the level and add more liquid if necessary.

14.12 - Hydraulic system maintenance

14.12.1 - Hydraulic oil: Check and replacement

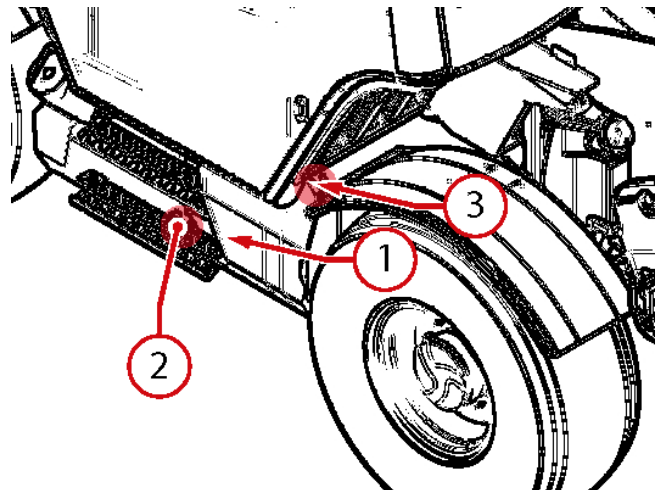

Figure: fig.150980-1

The hydraulic oil tank is located on the rear side of the vehicle, in the central part "1" (fig. 150980-1).

The level can be checked through the transparent cap placed on the right side of the vehicle "2".

The level is correct when the oil is visible from the transparent cap "2" with all the cylinders of the vehicle in the transport position.



NOTE

See the chapter "Technical data" to know the amount and type of recommended oil.

Oil check

To keep the vehicle in normal operation conditions, it is necessary to keep the oil level in best conditions.

To properly check the oil level in the tank it is necessary to:

- Prepare the vehicle in the maintenance position.
- Make sure that all cylinders and jacks of the vehicle are retracted (e.g. telescopic boom fully retracted and lowered, attachment holding plate tilted down as much as possible to avoid contact with chassis or tyres). In this way all the oil of the hydraulic circuit will be sent in the tank.
- Check the oil level through the transparent cap "2". Under the best conditions, the oil level reaches the middle of the transparent indicator.
- If necessary, remove the cap "3" and add oil until it reaches the proper level.

Oil change

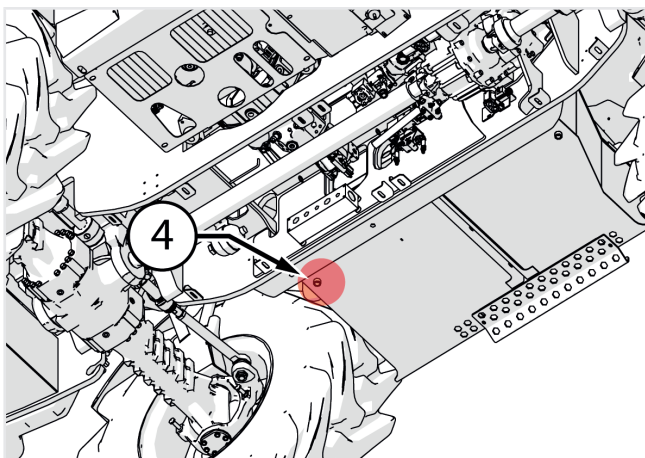

Figure: 150735-2

To change the oil in the tank it is necessary to:

- Prepare the vehicle in the maintenance position.
- Make sure that all cylinders and jacks of the vehicle are retracted (e.g. telescopic boom fully retracted and lowered, attachment holding plate tilted down as much as possible to avoid contact with chassis or tyres). In this way all the oil of the hydraulic circuit will be sent in the tank.
- Place a container under the drain plug (located under the tank).
- Remove the filling cap "3"
- Remove the drain plug to let the oil drain "4".

- Put back the drain plug "4".
- Fill the tank with the oil indicated
- Check the level through the indicator "2" after starting the engine and operated all hydraulic controls to remove air bubbles, if any.
- If necessary, top up the level.

14.12.2 - Hydraulic oil intake filter: Replacement

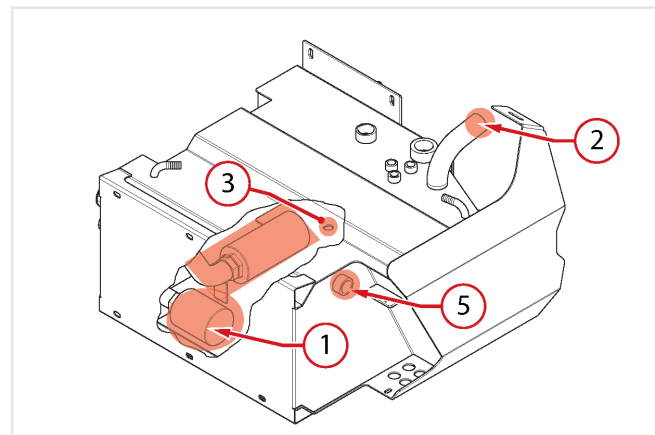

Figure: 150736-1

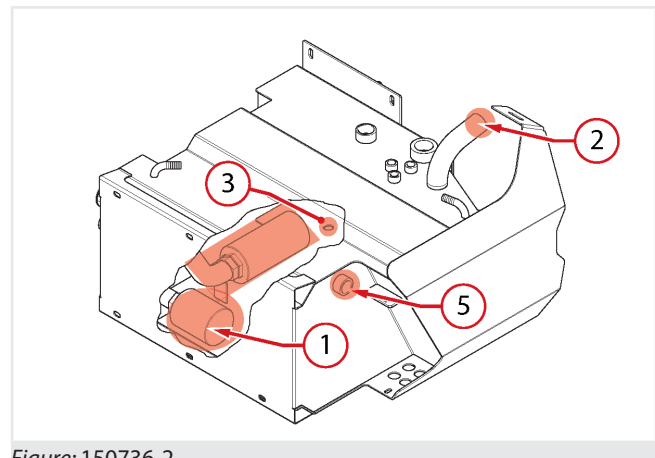

Figure: 150736-2

The internal hydraulic oil intake filters "1" (fig. 150736-1) are located inside the hydraulic oil tank; to replace them, completely empty the tank. It is therefore advisable to carry out the replacement of the intake filters in conjunction with the oil change.

To replace the intake filter, carry out the following operations (fig. 150736-1 and fig. 150736-2):

- Prepare the vehicle in the maintenance position.
- Make sure that all cylinders and jacks of the vehicle are retracted (e.g. telescopic boom fully retracted and lowered, attachment holding plate

tilted down as much as possible to avoid contact with chassis or tyres). In this way all the oil of the hydraulic circuit will be sent in the tank.

- Place a container under the drain plug (located under the tank).
- Remove the filler cap "2".
- Remove the drain plug to let the oil drain "3".
- After completely draining the oil, remove the flange "4" to access to the intake filters.
- Unscrew the intake filters "1" located inside the tank with an adjustable spanner.
- Install new filters and tighten with a wrench.
- Put back the drain plug "3".
- Fill the tank with the oil indicated.
- Check the level through the indicator "5" after starting the engine and operated all hydraulic controls to remove air bubbles, if any.
- If necessary, top up the level.

14.12.3 - Hydraulic oil return filter

To replace the hydraulic oil filter (fig. 150736-2) carry out the following operations:

- Prepare the vehicle in the maintenance position.
- Turn on the vehicle and lift the boom just enough to insert the safety rod on the lifting cylinder rod.
- Turn off the engine and remove the ignition key, place a sign in the cab showing "Maintenance in progress".
- Allow engine and hydraulic oil to cool down.
- Insert the "boom support" safety rod on the rod of the lifting cylinder, apply appropriate safety supports to the telescopic boom.
- Place a container under the oil filter to collect the oil that may spill during the change.
- Replace the filter, lightly oil the gasket and tighten by hand for 3/4 of a turn.

14.13 - 2 speed transmission maintenance

14.13.1 - Oil change: Inspection

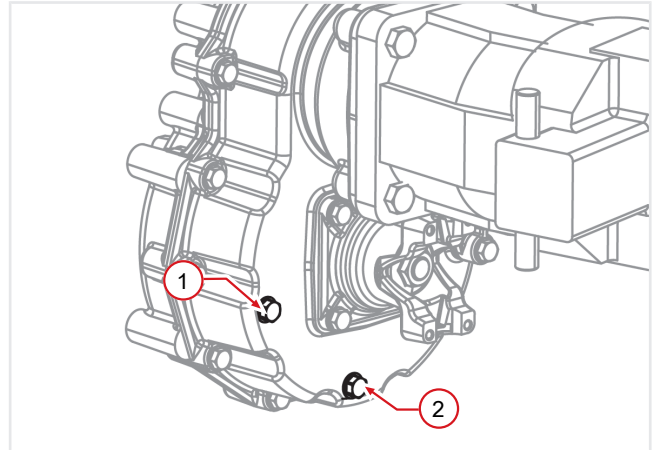

Figure: 150619-1

- Set the vehicle in the maintenance position.
- Place a container under the gearbox.
- Take the level cap off "1" (fig. 150619-1), oil must leak out from the hole.
- If necessary, top-up through the hole of the cap until the oil seeps through

14.13.2 - Oil change: Check and replacement

- Set the vehicle in the maintenance position.
- Place a container under the gearbox.
- Remove the level cap "1" (fig. 150619-1) and the drain plug "2".
- Allow the oil to completely drain out.
- Refit the drain plug and tighten it securely.
- Top-up with approved type of oil from cap "1" until the oil seeps through.

14.14 - Brakes maintenance

14.14.1 - Brake: Inspection

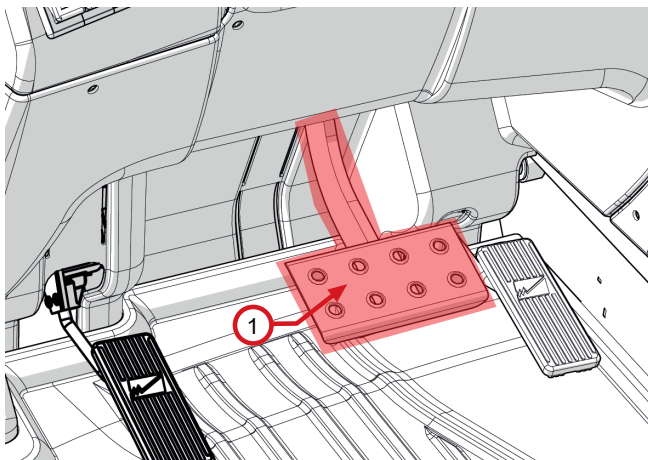

Figure: 180420-1

Visually check that the joints of the pedals (fig. 180420-1) are not damaged and that the pedal stroke is not excessive or too elastic.



DANGER

If irregularities in braking are noticed, contact qualified personnel to verify the cause of the trouble.

The braking parts also safeguard the operator's safety, do not intervene personally on the braking system trying to eliminate possible anomalies.

14.14.2 - Brakes oil: Check and replacement

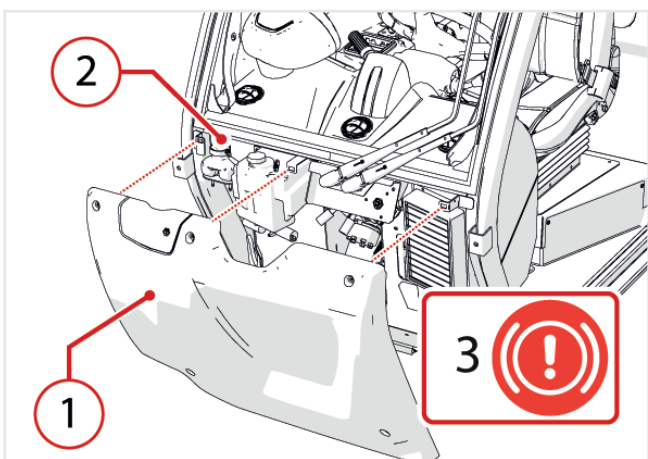

Figure: 180421-1

When the indicator light "3" (Brake fluid level low) flashes on the central instrument, it means that the brake fluid level has dropped below the minimum (MIN) and therefore it must be restored.

To access the tank, remove the front protection housing of the cab "1" (fig. 180421-1) and check that the oil level is always above the minimum level (MIN) indicated on the tank "2". If necessary top up from the cap.

WARNING! If the light "3" stays on even after adding oil, contact a Dieci authorized service center to solve the problem.

A slight lowering of the level is due to normal wear of the brake discs.

Do not press the brake pedal until the topping up is completed. Make sure the tank is closed before acting on the pedal.

14.15 - Wheel maintenance

14.15.1 - Epicycloidal reduction gear oil: Check and replacement

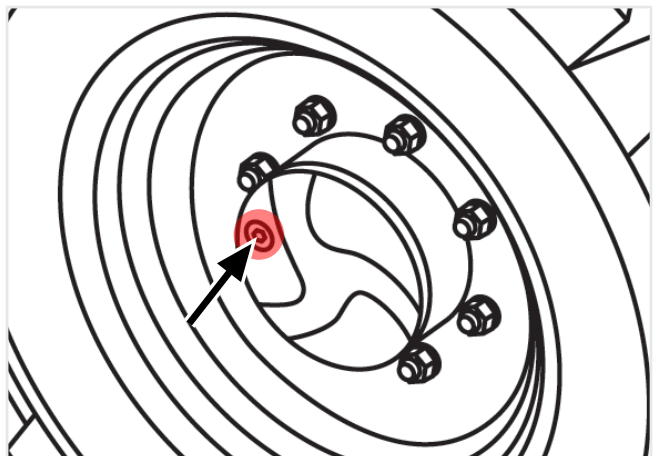

Figure: 150577-1

The oil cap of the epicycloidal reduction gear is located on the wheel hub (fig. 150577-1):

When checking the oil level it is necessary to:

- Prepare the vehicle in the maintenance position.
- Turn the wheel for the oil cap to be in the horizontal position (9 o'clock).
- Place a container to collect the oil.
- Remove the cap and verify that the oil seeps from the hole.
- If necessary, top-up through the same hole.
- Close the cap and tighten it securely.

When replacing the oil it is necessary to:

- Prepare the vehicle in the maintenance position.
- Turn the wheel for the oil cap to be in the lowest possible position (6 o'clock).
- Place a container to collect the oil.
- Remove the cap and let the oil drain completely.

- Turn the wheel and bring the cap to the horizontal position (9 o'clock).
- Fill through the same cap with new oil until it seeps through.
- Close the cap and tighten it securely.

14.15.2 - Wheel nuts tightening



NOTE

Tighten the nuts at the intervals required in the maintenance table.

Use the corresponding table to know the correct tightening torque.

Always tighten the nuts in opposing position, not consecutively.

After installing the wheel, tighten the nuts between the wheel and the axles. Then check the nut torque every day until the torque is stabilized.

The number of axle columns must match the number of nuts tightened. Then all the nuts on each wheel must be installed otherwise the vehicle can not operate.

In case of wheel replacement the vehicle or the raised side can be placed on the ground only with wheels installed and properly tightened.

The nuts tightening must be made first with the vehicle, or part of it, raised from the ground then with vehicle resting on the ground.

Only use **DIECI** original nuts for tightening the wheels. If you lose even one nut contact the **DIECI** service center.

14.15.2.1 - Wheel nuts tightening: Inspection

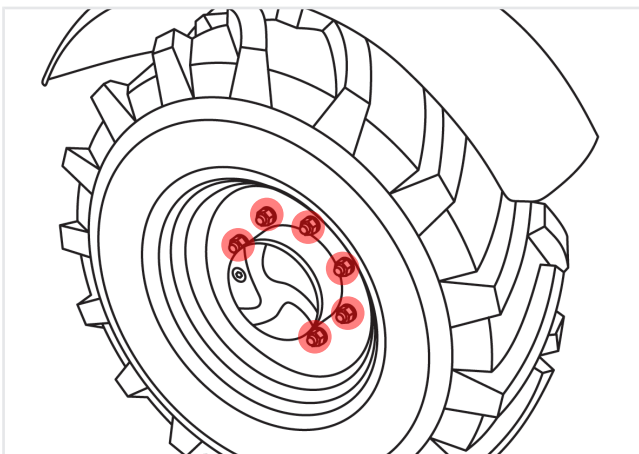

Figure: 150578-1

Check that the nuts of the front and rear wheels are tightened well, using a torque wrench (with a torque multiplier, if necessary).

Tapered nut	Torque
M18x1.5	360 N·m (339,02 ft·lbs)
M22x1.5	650 N·m (545,38 ft·lbs)

14.15.3 - Tires



ATTENTION

The diagrams notebook in the cab and in the "Technical data" chapter show the tires available for your vehicle model and the relative inflation pressures.



ATTENTION

On receiving the vehicle check the air pressure of the tires.

- Check the tire pressure regularly. The pressure must be checked with cold tires.
- The tire pressure must always be at the levels indicated.
- Check the size of the tires installed and the canvass amount for the correct inflation pressure.



DANGER

Tires showing cuts or excessive wear must be replaced immediately.

- At each use, check that the tire shoulders are not damaged.
- Keep oil, grease and corrosive liquids away from the tires to avoid deterioration of the rubber.
- To obtain the maximum efficiency do not use tires with more than 80% of tread wear.



WARNING

Inflating or operating on the tires can be dangerous.

To operate on tires or install them, contact specialized personnel.

In any case, to prevent serious or fatal injuries, follow the safety precautions below.

- The vehicle wheels are very heavy. Handle with care and make sure that, once stored, they can not fall and injure someone.
- Never try to repair a tire on a public road or highway.

- Make sure the jack is placed on a solid and flat surface.
- Make sure the jack is adequate for lifting the vehicle.
- Use ratchet jacks or other locking means suitable to support the vehicle during the tires repair.
- Do not place any part of the body under the vehicle.
- Do not start the engine while the vehicle is on the jack.
- Never hit a tire or a rim with a hammer.
- Make sure the rim is clean, without rust and undamaged. Do not weld, solder, repair in any way or use a damaged rim.
- Do not inflate a tire unless the rim is mounted on the vehicle or secured in such a way that it cannot move in case the tire or rim should break suddenly.
- Do not inflate any tire over the pressure indicated by **DIECI**. If the bead chafer does not settle on the rim, when arriving to this pressure deflate the tire and lubricate again with a solution of soap and water, inflate again. Do not use oil or grease. An inflation greater than permitted with bead chafer not settled may break the bead or rim with explosive force sufficient to cause serious injury.
- After installing the wheel, tighten the nuts between the wheel and the axles. Then check the nut torque every day until the torque is stabilized.



ATTENTION

When fitting a new or repaired tire, use a valve adapter of spring type with distant pressure gauge that allows the operator to stay well away from the tire during inflation.

Use a safety cage.

14.15.3.1 - Tire pressure: Inspection

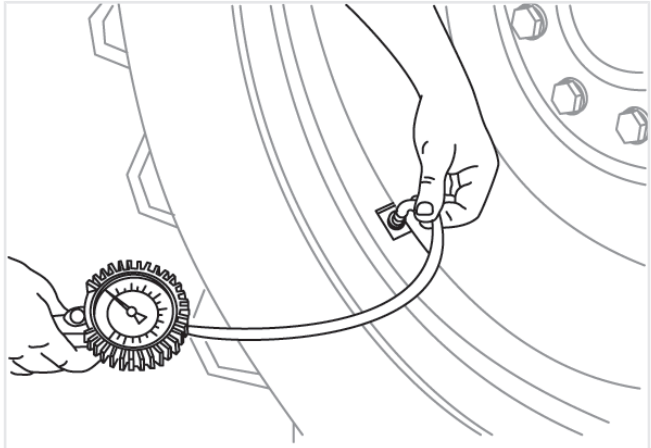

Figure: 150578-1

Verify and adjust the pressure of the front and rear tires.

Check that the tread and the sides are not damaged.

Connect a pressure gauge to the tire valve and verify that the inflation pressure is correct.

14.15.3.2 - Tires filled with urethane



NOTE

Tires filling with urethane is an optional accessory.

Consult your dealer in case of doubts or information on your vehicle.



DANGER

It is not permitted to fit tires inflated with polyurethane foam unless authorized by the manufacturer.

With tires filled with urethane it is forbidden to travel on the road.







ATTENTION

The maximum permitted speed with tires filled with urethane is 20 km/h (12.4 mph).

14.15.3.3 - Pneumatic symbols key

Icon	Description
	Tire dimension Indicate the tire pressure.
	Tread pattern

Icon	Description
	Indicates the design with which the tire tread is carved.
	Load index and Speed index The load index corresponds to the maximum load that the tire can support. The speed index indicates the maximum speed at which the tire can bear the weight corresponding to its load index.
	Tire pressure For most vehicle models, tire pressure is the same for all wheels.
	Front axle tire pressure For some vehicle models, the tires must be inflated with different pressures between the front axle and the rear axle.
	Rear axle tire pressure For some vehicle models, the tires must be inflated with different pressures between the front axle and the rear axle.

14.16 - Lighting

The vehicle lighting must always be efficient and fully functional. Its operation must be checked every day. In case of damage to the lighting system immediately replace the damaged part. Immediately replace a burned out bulb.



ATTENTION

Refer to the "Maintenance" chapter before making any adjustments or maintenance.



NOTE

The bulbs are very fragile. Handle with care.
The low beam bulbs must not be handled with bare hands.

14.16.1 - Headlight

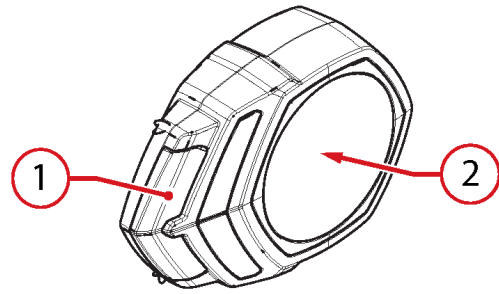

Figure: 150301-1

1	Direction indicator - 21 W
2	Front side light- 4 W
2	Low beam and high beam light - 60/55 W H4

To access the bulbs:

- Prepare the vehicle in the maintenance position.
- Turn off the battery isolation switch to disconnect power to the electrical system.
- Remove the power supply connector on the back of the light.
- Remove the front of the headlight by loosening the screws placed in the rear cap.

To close the headlight operate in the reverse order, paying attention to correct positioning of the sealing gasket.

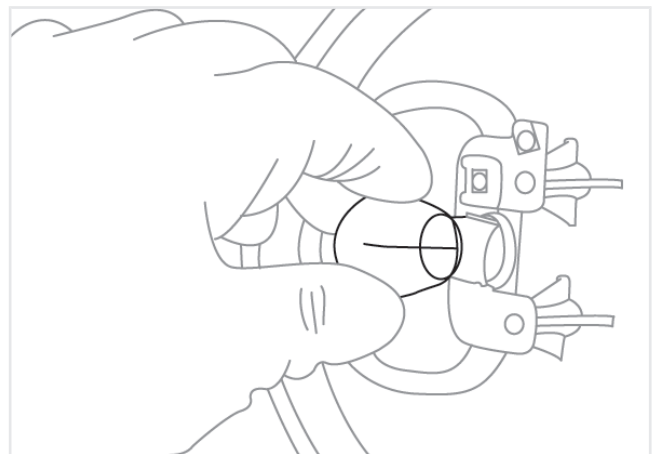

Figure: 150302-1

Direction indicator bulb replacement

- Press the top of the bulb (fig. 150302-1).
- Turn the bulb, keeping it pressed, to release it from the lock.
- Perform the same procedure to insert the new bulb.

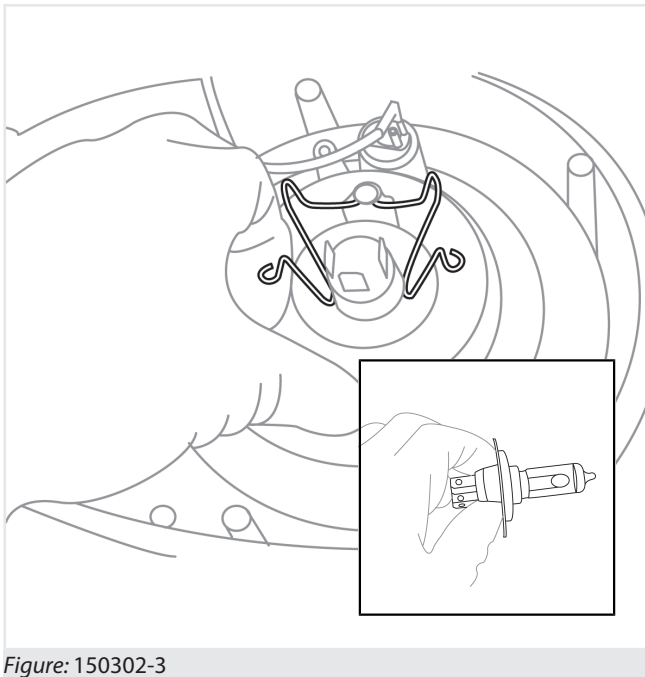

Figure: 150302-3

Low/high beam light bulb replacement

- Remove the electrical connector pulling it towards you.
- Lift the locking tabs (fig. 150302-3) moving them sideways to release the bulb.
- After replacing the bulb, proceed in the reverse order to lock and connect it again. Observe the joints of the lamp for proper insertion.

14.16.2 - Tail light

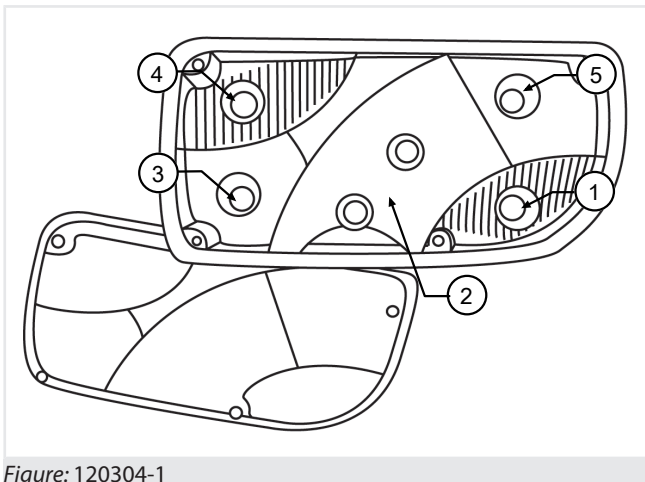

Figure: 120304-1

- | | |
|---|----------------------------|
| 1 | Reversing light - 21 W |
| 2 | Rear side light- 5 W |
| 3 | Braking light - 21 W |
| 4 | Direction indicator - 21 W |
| 5 | Rear fog light - 21 W |

To access the bulbs:

1. Prepare the vehicle in the maintenance position.
2. Turn off the battery isolation switch to disconnect power to the electrical system.
3. Remove the power supply connector on the back of the light.
4. Remove the front of the headlight by loosening the screws placed in the cap.

To close the headlight operate in the reverse order, paying attention to correct positioning of the sealing gasket.

Tail light bulb replacement.

- Press the top of the bulb.
- Turn the bulb, keeping it pressed, to release it from the lock.
- Perform the same procedure in reverse order to insert the new bulb.

14.16.3 - Work light *



NOTE

* The work light is an optional accessory.

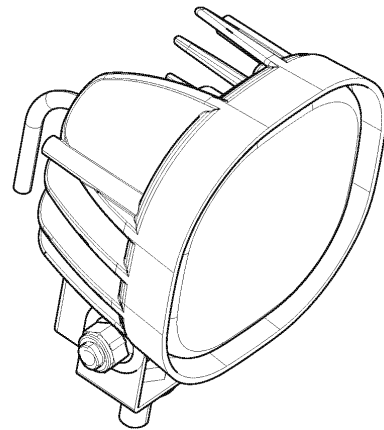

Figure: 150305-1

The work light (fig. 150305-1) does not require maintenance.

14.16.4 - Led work light*



NOTE

* The LED work light is an optional accessory.

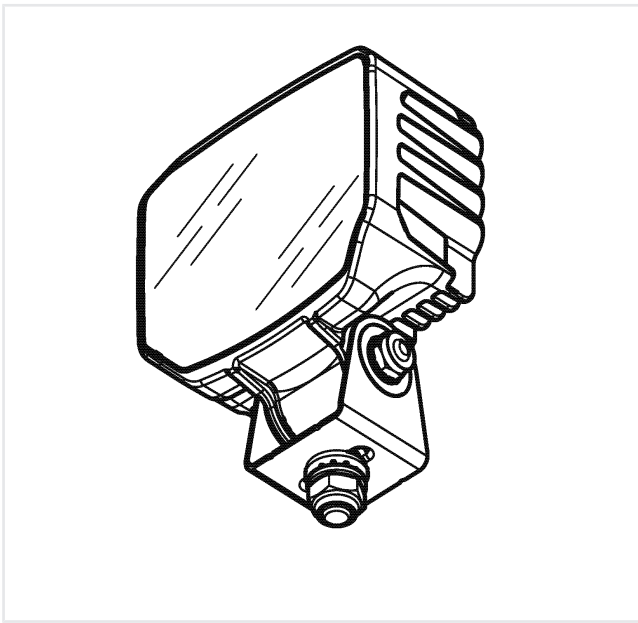

Figure: 150305-1

The LED work light (fig. 150303-1) does not require maintenance.

14.17 - Window washer fluid tank

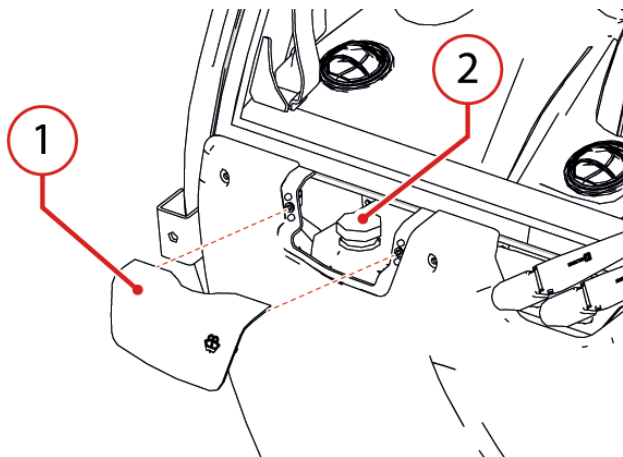

Figure: 150466-1

The washer fluid tank is located on the front external right side of the cab (fig. 150466-1).

To add liquid to the tank:

1. Remove the cover with magnetic inserts "1".
2. Remove the filling cap "2"
3. Add washing fluid to fill the tank.
4. Put back the cap.
5. Reassemble the cover.



ATTENTION

During the winter, mix antifreeze fluid to the water.

14.18 - Ventilation system maintenance

14.18.1 - Cab ventilation filter: Cleaning and replacement



DANGER

Do not use diesel fuel, gasoline, solvents or water to clean the cartridges, as this may damage the filtering material.



WARNING

If the vehicle is used in environments particularly rich of dust (barns, etc.), the filter life is reduced to 100 hours.



WARNING

In case of malfunction of the ventilation system, check the filter clogging.

In the event that the malfunction continues despite the filter replacement, contact DIECI service centre.



DANGER

Do not use the vehicle without a cab filter.

The entry of dust into the cab may involve risks to the health of the operator and breakage of the ventilation system.

Internal air filter replacement

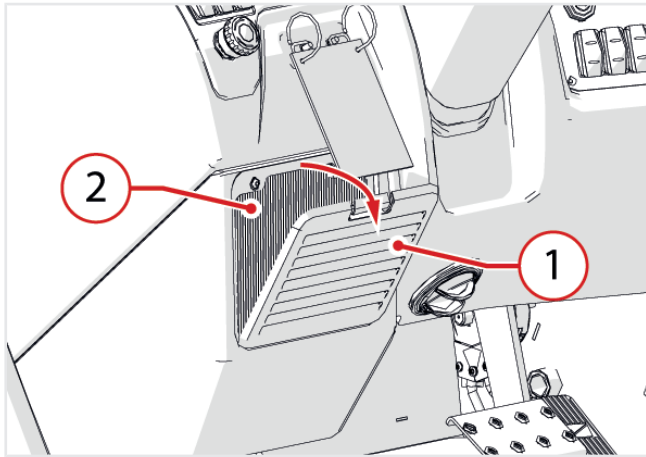

Figure: 180444-1

To replace the internal air filter in the cab, it is necessary to (fig. 180444-1):

- Open the cover "1",
- Remove and replace the filter "2",
- Reassemble the cover "1".

Replacement of external air filter

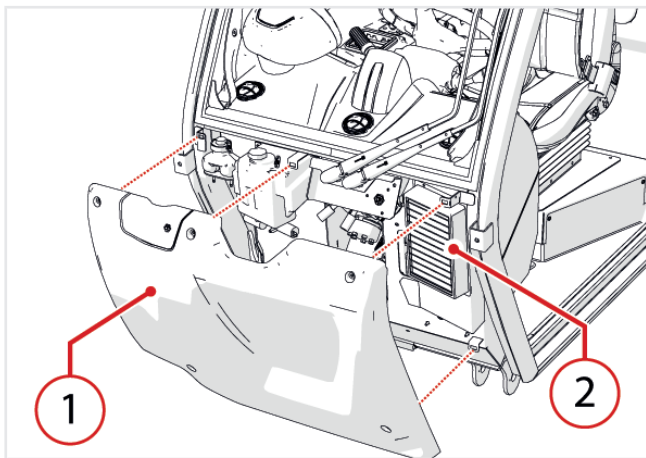

Figure: 180444-2

To replace the external air filter in the cab, it is necessary to (fig. 180444-2):

- Open the front protection housing "1",
- Remove and replace the filter "2",
- Put back the front protection housing "1".

14.18.2 - Air conditioning: Cleaning *



NOTE

* Air conditioning is an optional accessory.

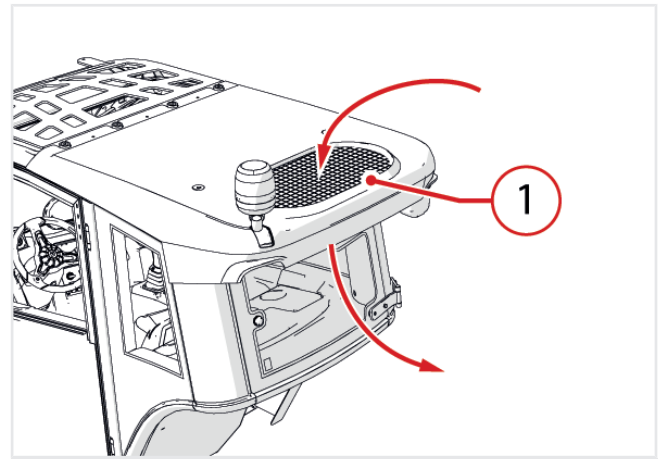

Figure: 180445-1

To clean the air conditioning radiator, it is necessary to (fig. 180445-1):

- Prepare the vehicle in the maintenance position.
- Clean the air conditioning radiator "1" directing compressed air at a maximum pressure of 7 bar, from the top downwards, in the direction opposite to that of the normal flow of air. The air flow must be perpendicular to the radiator surface.
- Remove dirt from under the air conditioning radiator.



ATTENTION

Be careful not to damage the radiator fins while cleaning.

Check that the fins are not deformed; in that case straighten with caution.

14.19 - Boom maintenance

14.19.1 - Sliding blocks maintenance

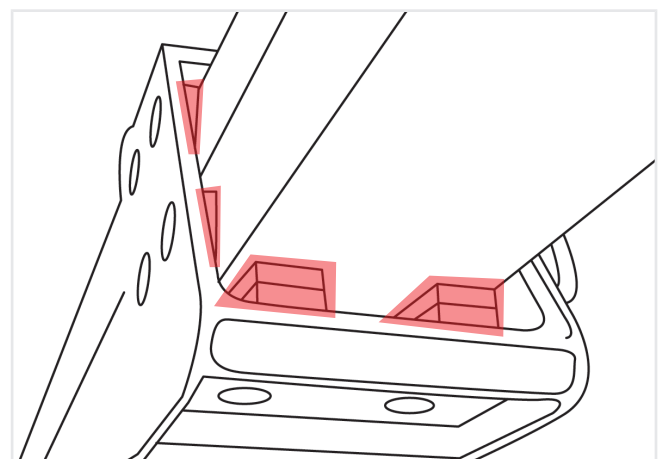

Figure: 150571-1

Worn sliding blocks can lead to oscillations and clearances between one extension and the other with consequent loss of precision in the movements and danger of load falling.

- For the deadlines see the summary table at the beginning of the chapter.
- With severe working conditions the wear is greater.



ATTENTION

Maintenance to the telescopic boom sliding blocks must be performed by authorized **DIECI** service.

14.19.2 - Boom lubrication with grease

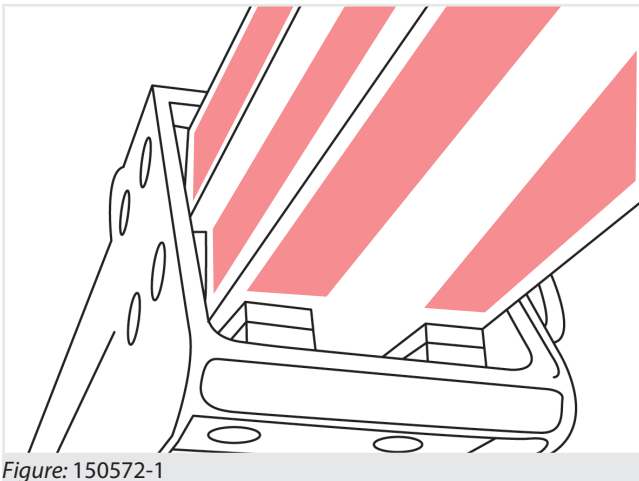

Figure: 150572-1

The boom sliding blocks must be kept lubricated to prevent as much as possible the deterioration and maintain soft movements.

- If the grease layer is thin or if impurities (sand, dust, shavings, etc ...) are present, proceed as follows:
- Prepare the vehicle in the maintenance position.
- Turn on the vehicle.
- Fully extend the boom and keep it in horizontal position.
- Turn off the engine and remove the ignition key, place a sign in the cab showing "maintenance in progress".
- Disconnect the battery using the battery cut-off switch.
- Remove the layer of grease and impurities on the surface of the extensions with a cloth.
- Use a brush to apply a layer of approved type grease on all four sides of the extensions.
- Turn on the vehicle.

- Fully retract and extend the boom several times to evenly distribute the grease.
- Turn off the vehicle.
- Remove excess grease.



ATTENTION

Use only lubricants recommended by **DIECI**, different lubricants may cause severe damage to the sliding surfaces.



WARNING

During the grease visual check and application the vehicle must be turned off and the key removed from the cab to avoid accidental operation.



NOTE

See the "Maintenance Log" chapter to know the maintenance intervals timing.

When using the vehicle in severe conditions, very dusty environment requires a more frequent greasing.

14.20 - Cylinders block valves maintenance

The block valves for cylinders prevent uncontrolled movement of the pistons of the cylinders in the event of hydraulic pressure failure or bursting of a hose.

The valves are installed directly on the cylinders.



DANGER

During the checking operations do not allow any person to stay within the radius of action of the vehicle.

Check the valves individually.

In case of malfunction do not use the vehicle until it has been repaired.

Boom lifting cylinders:

- Start the engine. Make sure that the parking brake is engaged and the transmission is in neutral.
- Lift the boom to approximately 45°.

- With the engine running at 1400 rpm, lower the boom. During the boom movement stop the engine.

The boom movement must slow down and then stop when the engine slows down and stops.



DANGER

If the boom continues to move after stopping the engine, the lifting cylinders block valve is faulty.

Remove the fault as soon as possible, contact the *DIECI* service center.

Boom extension cylinder:

- Start the engine. Make sure that the parking brake is engaged and the transmission is in neutral.
- Lift and fully extend the boom.
- With the engine running at 1400 rpm, retract the boom. During the boom movement stop the engine.

The boom movement must slow down and then stop when the engine slows down and stops.



DANGER

If the boom continues to move after stopping the engine, the extension cylinders block valve is faulty.

Remove the fault as soon as possible, contact the *DIECI* service center.

Forks tilting cylinders:

- Start the engine, take a load on the forks (for example, a load of bricks or some bales of hay).
- Tilt the forks fully upward.
- Engage the parking brake and set the transmission into neutral.
- Tilting the boom away from the ground sufficiently to allow the forks to tilt forward.
- With the engine running at 1400 rpm, operate the control lever to tilt the plate forward. During the forks movement stop the engine.

The tilting movement must slow down and then stop when the engine slows down and stops.



DANGER

If the forks continue to move after stopping the engine, the tilting cylinders block valve is faulty.

Remove the fault as soon as possible, contact the *DIECI* service center.

Leveling and oscillating block cylinders (if any):

- Position the vehicle on a perfectly horizontal surface.
- Make sure that the parking brake is engaged and the transmission is in neutral.
- Make sure the vehicle is in carriage mode.
- Lift the boom about 15 cm from the ground and level the vehicle so that the chassis is perfectly parallel to the surface (check the level in the cab).
- Check that, without intervening on the leveling control, the vehicle maintains this position even after a prolonged use.



DANGER

If the chassis continues to move after stopping the engine, the leveling cylinders block valve is faulty.

Remove the fault as soon as possible, contact the *DIECI* service center.



NOTE

Do not level the vehicle with boom raised and/or removed.

Outriggers cylinders (if present)

- Start the engine. Make sure that the parking brake is engaged and the transmission is in neutral.
- Place the vehicle on outriggers.
- Level the vehicle with the outriggers.
- Fully extend the boom.
- With the engine running at idle speed, rotate the vehicle turret.



DANGER

If the outriggers continue to move after stopping the engine, the outriggers cylinders block valve is faulty.

Remove the fault as soon as possible, contact the *DIECI* service center.

- Close the drain plug "3".
- Load new oil from the filler cap "1", up to make oil seep out from the level cap "2".

Put back the caps and tighten down.



WARNING

Replace oil in the differential axles after the first 100 hours of use.

Failure to replace the running-in oil will compromise the correct operation of the differential axles

14.21 - Differential Axles Maintenance

14.21.1 - Differential axles oil: Check and replacement

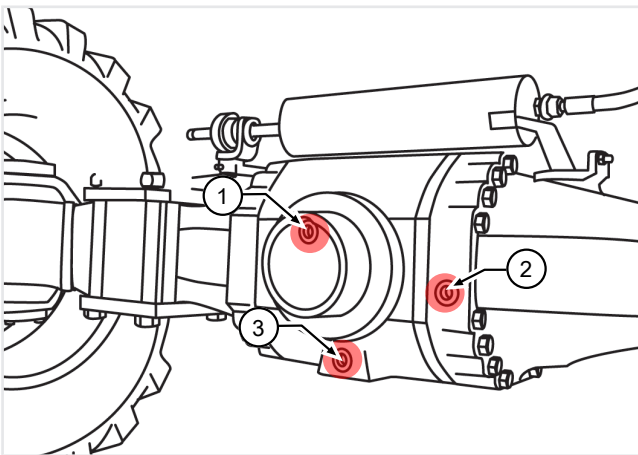

Figure: 150579-1

The filler, level and drain caps are located in the central part of the front and rear differential axle (fig. 150579-1):

When checking the oil level it is necessary to:

- Prepare the vehicle in the maintenance position.
- Place a container for the oil recovery under the level plug "2" to collect any leaks.
- Open the level cap "2". In the best conditions oil must seep out from the hole.
- If necessary, open the cap "1" and top up to make oil seep out from the level cap "2".
- Put back the caps and tighten down.

When replacing the oil it is necessary to:

- Prepare the vehicle in the maintenance position.
- Place a container for the oil recovery under the drain plug "3" to collect any leaks.
- Open the filler cap "1" and then the drain cap "3".
- Drain off all the oil.

14.22 - Hydraulic fittings tightening torques

Inserts with 60° nose - BSP thread

Thread	1/18.28	1/4.19	3/8-19	1/2-14	5/8-14	3/4-14	1"-11	1"1/4-11	121/2-11
(N·m)	12-14	14-16	25-28	45-60	55-70	90-110	120-140	170-190	200-245

Inserts with 60° nose - METRIC thread

Thread	10x1	12x1.5	14x1.5	16x1.5	18x1.5	22x1.5	26x1.5	28x1.5	30x1.5
(N·m)	12-14	13-15	15-18	25-28	27-30	50-60	60-75	80-100	110-130

SERIES DIN RANGE „L“

Thread	12x1.5	14x1.5	16x1.5	18x1.5	22x1.5	26x1.5	30.2	36x1.5	45x1.5	52x1.5
(N·m)	13-15	15-18	25-28	27-30	50-60	30-75	85-105	120-140	170-190	190-230

SERIES DIN RANGE „S“

Thread	14x1.5	16x1.5	18x1.5	20x1.5	22x1.5	24x1.5	30x2	36x2	42x2	52x2
(N·m)	15-18	25-28	27-30	43-54	50-62	60-75	90-110	125-145	170-190	200-245

14.23 - Torque specifications - fasteners

14.23.1 - Torque specifications - fasteners: Fine pitch

	Coefficient of friction	4.8		5.8		6.8		8.8		10.9		12.9	
		Preload (N)	Tightening torque: (Nm)	Preload (N)	Tightening torque: (Nm)	Preload (N)	Tightening torque: (Nm)	Preload (N)	Tightening torque: (Nm)	Preload (N)	Tightening torque: (Nm)	Preload (N)	Tightening torque: (Nm)
M8	0.10	9798	10.87	12248	13.59	14697	16.31	19596	21.75	27557	30.58	33069	36.70
	0.14	9080	13.53	11349	16.91	13619	20.29	18159	27.05	25536	38.04	30643	45.65
M10	0.10	15297	21.13	19121	26.41	22945	31.69	30594	42.25	43023	59.42	51627	71.30
	0.14	14175	26.27	17719	32.84	21263	39.41	28350	52.55	39867	73.89	47841	88.67
M10	0.10	16384	22.12	20480	27.66	24575	33.19	32767	44.25	46079	62.23	55295	74.67
	0.14	15222	27.80	19027	34.75	22833	41.70	30443	55.61	42811	78.20	51373	93.84
M12	0.10	22021	35.83	27526	44.79	33031	53.75	44041	71.67	61933	100.78	74320	120.94
	0.14	20406	44.53	25507	55.66	30609	66.79	40812	89.06	57391	125.24	68870	150.29
M12	0.10	23334	37.26	29167	46.57	35001	55.88	46667	74.51	65626	104.78	78751	125.74
	0.14	21669	46.70	27087	58.38	32504	70.06	43338	93.41	60945	131.36	73134	157.63
M14	0.10	31610	59.04	39513	73.80	47415	88.57	63220	118.09	88903	166.06	106684	199.27
	0.14	29346	73.92	36682	92.40	44019	110.89	58692	147.85	82535	207.91	99043	249.49
M16	0.10	42581	89.78	53227	112.23	63872	134.67	85163	179.56	119760	252.51	143712	303.02
	0.14	39588	113.06	49485	141.32	59382	169.59	79176	226.12	111341	317.98	133609	381.57
M18	0.10	51457	124.03	64322	155.03	77186	186.04	102914	248.06	144723	348.83	173668	418.59
	0.14	47752	155.02	59690	193.78	71628	232.53	95503	310.05	134302	436.00	161162	523.20
M18	0.10	55415	130.17	69269	162.72	83123	195.26	110830	260.35	155855	366.12	187026	439.34
	0.14	51578	164.67	64472	205.84	77366	247.01	103155	329.35	145062	463.15	174075	555.77
M20	0.10	65534	173.72	81918	217.16	98301	260.59	131068	347.45	184315	488.60	221178	586.32
	0.14	60886	218.17	76108	272.71	91329	327.26	121772	436.34	171243	613.61	205491	736.33
M20	0.10	70115	181.58	87643	226.97	105172	272.36	140229	363.15	197198	51.68	236637	612.82
	0.14	65319	230.55	81649	288.19	97979	345.82	130638	461.10	183710	648.42	220452	778.10

	Coefficient of friction	4.8		5.8		6.8		8.8		10.9		12.9	
		Preload (N)	Tightening torque: (Nm)	Preload (N)	Tightening torque: (Nm)	Preload (N)	Tightening torque: (Nm)	Preload (N)	Tightening torque: (Nm)	Preload (N)	Tightening torque: (Nm)	Preload (N)	Tightening torque: (Nm)
M22	0.10	81221	236.88	101526	296.10	121831	355.32	162442	473.76	228433	666.23	274120	799.48
	0.14	75534	298.75	94417	373.43	113301	448.12	151068	597.49	212439	840.22	254927	1008.27
M22	0.10	86164	246.02	107705	307.53	129246	369.04	172329	492.05	242337	691.94	290804	830.33
	0.14	80332	313.41	100415	391.76	120498	470.11	160664	626.82	225933	881.46	271120	1057.75
M24	0.10	98516	308.56	123145	385.70	147773	462.84	197031	617.12	277075	867.83	332490	1041.40
	0.14	91693	390.33	114617	487.92	137540	585.50	183387	780.67	257887	1097.82	309465	1317.38
M24	0.10	104079	319.62	130099	399.52	156119	479.43	208152	639.23	292723	898.92	351268	1878.71
	0.14	97096	408.12	121370	510.15	145644	612.18	194192	816.24	273083	1147.84	327699	1377.41
M27	0.10	127922	448.43	159903	560.54	191884	627.65	255845	896.87	359782	1261.22	431738	1513.46
	0.14	119185	569.67	148981	712.09	178778	854.51	238370	1139.34	335208	1602.20	402250	1922.64
M30	0.10	16818	623.80	201022	779.75	241226	935.70	321635	1247.60	452299	1754.43	542759	2105.32
	0.14	149957	795.14	187446	993.93	224936	1192.72	299914	1590.29	421754	2236.34	506105	2683.61

14.23.2 - Torque specifications - fasteners: Coarse pitch

	Coefficient of friction	4.8		5.8		6.8		8.8		10.9		12.9	
		Preload (N)	Tightening torque: (Nm)	Preload (N)	Tightening torque: (Nm)	Preload (N)	Tightening torque: (Nm)	Preload (N)	Tightening torque: (Nm)	Preload (N)	Tightening torque: (Nm)	Preload (N)	Tightening torque: (Nm)
M3	0.10	1220	0.54	1525	0.68	1830	0.82	2440	1.09	3431	1.53	4117	1.84
	0.14	1126	0.60	1407	0.83	1689	1.00	2252	1.34	3167	1.88	3800	2.26
M3.5	0.10	1638	0.84	2048	1.05	2457	1.26	3276	1.68	4608	2.36	5529	2.84
	0.14	1511	1.03	1889	1.28	2267	1.54	3023	2.05	4251	2.89	5101	3.47
M4	0.10	2115	1.25	2644	1.56	3173	1.88	4231	2.50	5950	3.52	7140	4.22
	0.14	1951	1.53	2439	1.91	2926	2.29	3902	3.06	5487	4.30	6584	5.16
M5	0.10	3462	2.46	4327	3.08	5192	3.70	6923	4.93	9736	6.93	11683	8.32
	0.14	3197	3.02	3996	3.78	4795	4.53	6394	6.04	8991	8.50	10789	10.20
M6	0.10	4875	4.24	6093	5.30	7312	6.35	9749	8.47	13710	11.92	16452	14.30
	0.14	4499	5.19	5624	6.48	6749	7.78	8998	10.37	12654	14.59	15184	17.51
M7	0.10	7135	6.97	8918	8.71	10702	10.45	14269	13.94	20066	19.60	24079	23.52
	0.14	6600	8.60	8250	10.76	9899	12.90	13199	17.21	18561	24.20	22274	29.04
M8	0.10	8947	10.20	11184	12.75	13421	15.30	17894	20.41	25164	28.70	30197	34.44
	0.14	8266	12.54	10332	15.67	12398	18.80	16531	25.07	23247	35.26	27897	42.31
M10	0.10	14245	20.11	17806	25.14	21367	30.16	28489	40.22	40063	56.56	48075	67.87
	0.14	13167	24.76	16459	30.95	19751	31.14	26335	49.52	37033	69.64	44440	83.56
M12	0.10	20767	34.43	25958	43.03	31150	51.64	41533	68.86	58406	96.83	70087	116.20
	0.14	19204	42.42	24005	53.03	28806	63.63	38408	84.84	54011	119.31	64814	143.17
M14	0.10	28390	54.77	35487	68.46	42585	82.15	56780	109.53	79847	154.03	95816	184.84
	0.14	26261	67.56	32827	84.45	39392	101.34	52522	135.13	73860	190.02	88632	228.03
M16	0.10	39242	85.14	49053	106.43	58863	127.72	78484	170.29	110369	239.47	132442	287.36
	0.14	36364	105.80	45455	132.26	54546	158.71	72729	211.61	102274	297.58	122729	357.09
M18	0.10	47533	117.48	59416	146.85	71300	176.22	95066	234.96	133687	330.41	160424	396.49
	0.14	43986	145.16	54983	181.45	65979	217.74	87972	290.32	123711	402.26	148453	489.92
M20	0.10	61238	166.08	76548	207.61	91857	249.13	122476	332.17	172232	467.11	206678	560.54

	Coefficient of friction	4.8		5.8		6.8		8.8		10.9		12.9	
		Preload (N)	Tightening torque: (Nm)	Preload (N)	Tightening torque: (Nm)	Preload (N)	Tightening torque: (Nm)	Preload (N)	Tightening torque: (Nm)	Preload (N)	Tightening torque: (Nm)	Preload (N)	Tightening torque: (Nm)
	0.14	56747	206.39	70934	257.98	85121	309.58	113494	412.78	159601	580.47	191522	696.56
M22	0.10	76305	227.22	95382	284.02	114458	340.82	152610	454.43	214608	639.05	257530	766.85
	0.14	70792	283.79	88490	352.74	106188	425.69	141584	567.58	199102	798.16	238923	957.80
M24	0.10	88232	287.16	110291	358.94	132349	430.73	176465	574.31	248154	807.63	297784	969.15
	0.14	81762	356.84	102202	446.05	122643	535.26	163524	713.68	229955	1003.61	275946	1204.33
M27	0.10	115779	420.40	144724	525.05	173668	930.06	231558	840.08	325628	1181.36	390753	1417.63
	0.14	107442	525.08	134302	656.35	161162	787.62	214883	1050.16	302179	1476.79	362615	1772.15
M30	0.10	141000	572.83	176249	716.03	211499	859.24	281999	1145.65	396561	1611.08	475873	1933.29
	0.14	130771	714.49	163463	893.11	196156	1071.73	261541	1428.97	367792	2009.49	441351	2411.39

Local Dealers can supply original spare parts as well as advice and instructions for their installation and use.

Use only original spare parts when they are required.

The use of non-original spare parts may cause damage to other parts of the vehicle. Customers are advised to purchase all original spare parts required only from an authorized Agent or Dealer.

DIECI s.r.l. does not consider itself liable for damage deriving from the use of non-original spare parts.

15.1 - Spare parts supply

DIECI s.r.l. guarantees the supply of original spare parts or alternatives for 10 years from the date of the last model produced of the series concerned.

15.2 - Assistance to owner / operator

In order to obtain a good service from your Dealer, please obtain of these fundamental data before contacting the service center:

1. Specify your name, address and telephone number.
2. Indicate the model and serial number of the vehicle chassis.
3. Indicate the date of purchase and the hours of operation.
4. Explain the nature of the fault.

Note that only DIECI Dealers can access the resources at DIECI site for customer service. Moreover, they are able to offer a variety of programs with regard to warranty, maintenance at a fixed price, safety checks, including tests

15.3 - Technical Assistance Service address

Dieci Technical Assistance Service

Via E. Majorana, 2/4

42027 Montecchio Emilia (RE) ITALY

Tel. +39 0522 869611

Fax +39 0522 869744

service@dieci.com



WARNING

The interventions for the elimination of faults can only be carried out by trained personnel.

Do not work on failures if the "Safety regulations", "Safe Working Procedures" and "MAINTENANCE" have not been read and understood before.



This symbol indicates that the trouble experienced may NOT be resolved without the intervention of a **DIECI** Service authorized workshop



16.1 - Engine

PROBLEM	CAUSE	SOLUTION	
It does not set in motion	Direction of travel lever engaged	Place the lever in neutral	
	Parking brake deactivated	Activate it	
	No fuel	Fill the tank	
	Battery isolation switch disconnected	Connect the battery isolation switch	
	Low Battery	Recharge the battery or replace it	
	Fuse failure	Replace the fuse	
	Other	Consult the Use and Maintenance manual of the engine	



16.2 - Hydraulic transmission system

PROBLEM	CAUSE	SOLUTION	
The vehicle does not go in any direction	Insufficient hydraulic oil level	Check the hydraulic oil level	
	Hand throttle engaged	Release the hand throttle	
	The sensor built-in the seat does not report the presence of the operator	Sit properly at the driver's seat	
	The movement selection lever is not engaged	Engage the lever to the desired position	
	The outriggers are lowered (if installed)	Raise all outriggers fully up	
	Parking brake in operation	Disengage the brake	
	Electrical circuit failure	Repair the circuit	
	Hydrostatic transmission failure	Repair or replace the transmission	
The vehicle loses speed	The transmission ByPass tap has been opened (if installed)	Close the ByPass tap	
	Hydraulic oil intake filter clogged	Remove the oil filter and replace it	
	Inching pedal failure	Check the correct operation of the pedal and the valve	



16.3 - Brakes

PROBLEM	CAUSE	SOLUTION	
The vehicle does not brake	Lack of oil in the oil - brakes tank	Refill the tank and / or Purge the system	
	Loss of fluid from the circuit	Check for leaks	
	Brake discs worn	Replace the brake discs	
	Brake master cylinder failure	Repair or replace	
	Unsuitable fluid in the circuit or in the differential sump	Check the brake oil specifications indicated	

16.4 - Steering wheel

PROBLEM	CAUSE	SOLUTION	
The vehicle runs sideways The wheels are not aligned	The wheels are not correctly aligned	Align them	
	Steering selection error	Put back the lever in a different steering mode	
	Control distributor failure	Repair or replace the distributor	
	Leakage from the steering wheel hydraulic cylinders	Replace the gaskets	

16.5 - Telescopic boom

PROBLEM	CAUSE	SOLUTION	
The vehicle does not lift the load	They safety systems have activated	See the "Anti-tipping device" chapter	
	Electrical system failure	Check the fuses and electrical system	
	Hydraulic oil level in the tank insufficient	Top up	
	Relative hydraulic pump failure	Repair or replace the pump	
	Distributor low calibration	Check and re-calibrate the distributor	
	Lifting cylinders internal leak	Replace the gaskets	
The boom does not extend	"The safety systems have activated (Indicator light and audible alarm in operation)"	See the "Anti-tipping device" chapter	

PROBLEM	CAUSE	SOLUTION	
The boom does not come down	"The safety systems have activated (Indicator light and audible alarm in operation)"	See the "Anti-tipping device" chapter	

17.1 - Anti-tipping device errors list



NOTE

In case the vehicle is in error, contact a **Dieci** service centre to solve the problem, indicating the error code reported.

For more information about the errors display, refer to the "Central instrument panel" chapter.

Icon	Example	Description
	000	SAR errors ALGA errors

Error code	Description
SAR ERRORS	
11	CRC error in the memory area that contains the software
12	CRC error in the memory area that contains the parameters
13	Program flow control error
14	Data exchange error between the two micro controls
15	Out of range +7Vdc, +18Vdc power supply voltage error
16	Internal power supply voltage of the first channel out of range 4.8 Vdc, 5.2Vdc error
17	Internal power supply voltage of the second channel out of range 4.8 Vdc, 5.2Vdc error
21	Cut Off1 output status consistency error
22	Cut Off 2 output status consistency error
23	WDO1 output status consistency error
24	Output 1 status consistency error
25	Output 2 status consistency error
26	WDO2 output status consistency error
31	Load cell A: CRC error of the load cell internal parameters.
32	Load cell A: <ul style="list-style-type: none"> • Off range signal reading error (10 - 990) • With Vishay cell: <ul style="list-style-type: none"> – ± 12.55 mV/V – Sensor not installed

Error code	Description
	<ul style="list-style-type: none"> – Faulty sensor (power supply or CRC error sensor temperature table) – Sensor code not aligned with the supply voltage – Faulty A/D converter
33	Load cell A: Internal off range offset reading error (466-526)
34	Load cell A: Internal 5Vdc power supply error
35	Load cell A <ul style="list-style-type: none"> • Thermal calibration not present error • (Valid only with Vishay cell) Temperature reading outside the permitted limits, typically -20° +85°
36	Load cell A: LIN bus message check error
37	Load cell A: Transmitted data CRC error
38	Load cell A <ul style="list-style-type: none"> • LIN bus message receiving error • (Valid only with Vishay cell) CAN-BUS messages receiving time-out
39	Load cell A: LIN bus message control meter error
41	Load cell B: CRC error of the load cell internal parameters
42	Load cell B: <ul style="list-style-type: none"> • Off range signal reading error (10 - 990) • With Vishay cell: <ul style="list-style-type: none"> – ± 12.55 mV/V – Sensor not installed – Faulty sensor (power supply or CRC error sensor temperature table) – Sensor code not aligned with the supply voltage – Faulty A/D converter
43	Load cell B: Internal off range offset reading error (526-586)
44	Load cell B: Internal 5Vdc power supply error
45	Load cell B <ul style="list-style-type: none"> • Thermal calibration not present error • (Valid only with Vishay cell) Temperature reading outside the permitted limits, typically -20° +85°
46	Load cell B: LIN bus message check error
47	Load cell B: Transmitted data CRC error

Error code	Description
48	Load cell B: <ul style="list-style-type: none"> • LIN bus message receiving error • (Valid only with Vishay cell) CAN-BUS messages receiving time-out
49	Load cell B: LIN bus message control meter error
51	Too big difference between the readings of load cells A and B
52	Too big difference between load rates detected by channels 1 and 2
61	Outriggers on the ground double safety input consistency error.
62	Closed boom reading safety double input consistency error
63	Mode selector inputs consistency error
64	Exclusion key active at the start up error
65	Movements in block reset input active at the start up error.
66	Frequency feedback signal reading error
67	External actuator 1 feedback signal reading error
68	External actuator 2 feedback signal reading error
71	Analogue signal from joystick out of range reading error
72	Pressure transducer for joystick reset check reading error
73	CAN BUS messages receiving from the optional external unit error
81	Buttons pressed at the start up error
ALGA ERRORS	
90	Message Counter error (10FF80E3)
91	Message Timeout error (10FF80E3)
92	Message Counter error (18FFF0E3)
93	Message Timeout error (18FFF0E3)
94	SARL response error, different response value
95	Calibration pin not connected any more during the calibration phase
96	Safe Road Travelling Position inconsistency error
97	Internal errors to the panel available
98	Internal errors to the panel available
99	Internal errors to the panel available

17.2 - Braking circuit errors list



NOTE

In case the vehicle is in error, contact a *Dieci* service center to solve the problem, indicating the error code reported.

For more information about the errors display, refer to the "Instrument panel" chapter.

Icon	Example	Description
	00000000	Parking brakes errors or brakes failure

Code	Description
100	Service brake low oil level reporting (brake oil tank)
101	Parching brake system failure
102	Parking brake accumulator low pressure

17.3 - VCM errors

VEHICLE ERROR CODES			
ERROR CODE	DESCRIPTION	VEHICLE REACTION	CHECK
1.1	SARL plausibility error; TippingAlarm1 and TippingAlarm2 signals are inconsistent	No boom movement, except retraction. All movements reactivate from bypass key	Check the correct operation of SARL (HD/SW); check wiring
1.2	Open circuit fan reversal solenoid valve	Fan reversal does not work	Check the solenoid resistance, check wiring
1.3	(Ground or positive) short circuit fan drive solenoid valve	Fan drive function disabled (if to ground) or unintentionally activated (if to positive)	Check the solenoid resistance, check wiring
1.4	Open circuit fan drive solenoid valve	Fan drive function does not work	Check the solenoid resistance, check wiring
1.5	Open circuit top switch 1 solenoid valve	Top switch 1 function does not work	Check the solenoid resistance, check wiring
1.6	(Ground or positive) short circuit top switch 2 solenoid valve	Top switch 2 function disabled (if to ground) or unintentionally activated (if to positive)	Check the solenoid resistance, check wiring
1.7	Open circuit top switch 2 solenoid valve	Top switch 2 function does not work	Check the solenoid resistance, check wiring
1.8	Plausibility error of overload system: OverloadAlarm1 (digital) and OverloadAlarm2 (CAN BUS) signals are inconsistent	No boom movement, except retraction and auxiliary A (if winch only). All movements reactivate from bypass/recovery key or during calibration	Check the correct operation of SARL unit (HD/SW); check wiring
1.9	Battery voltage out of range	Power from battery disabled (for vehicles with DA/PS6/DRC transmission); safe/limited mode transmission (for vehicles with AoP transmission)	Check wiring
1.10	Voltage of output 8 of VCM out of range	Power to sensor disabled (for vehicles with DA/PS6/DRC transmission); safe/limited mode transmission (for vehicles with AoP transmission)	Check wiring
1.11	RPM+ key (in the cab or on the remote control) activated during engine start	RPM+ function disabled until the key is released	Check that the key has not been accidentally activated, check the key, check wiring
1.12	RPM- key (in the cab or on the remote control) activated during engine start	RPM- function disabled until the key is released	Check that the key has not been accidentally activated, check the key, check wiring
1.13	Linear joystick EV1 (rear hydraulic socket) activated during engine start	EV1 function disabled until the key is released	Check that the linear joystick has not been accidentally activated, check the linear joystick, check wiring

VEHICLE ERROR CODES			
1.14	Linear joystick EV2 (rear hydraulic socket) activated during engine start	EV2 function disabled until the key is released	Check that the linear joystick has not been accidentally activated, check the linear joystick, check wiring
1.15	Linear joystick EV3 (rear hydraulic socket) activated during engine start	EV3 function disabled until the key is released	Check that the linear joystick has not been accidentally activated, check the linear joystick, check wiring
1.16	Linear joystick EV1 (rear hydraulic socket): value out of range	EV1 function disabled	Check minimum and maximum values at linear joystick output; check wiring
1.17	Linear joystick EV2 (rear hydraulic socket): value out of range	EV2 function disabled	Check minimum and maximum values at linear joystick output; check wiring
1.18	Linear joystick EV3 (rear hydraulic socket): value out of range	EV3 function disabled	Check minimum and maximum values at linear joystick output; check wiring
1.19	FNR column switch plausibility error	FNR column switch disabled: transmission does not work	Check the outputs from FNR column switch; check wiring
1.20	FNR column switch not in neutral during engine start	FNR column switch disabled: transmission does not work until the column switch is released	Check that FNR column switch has not been accidentally activated; check that FNR column switch is not locked in forward gear and reverse gear; check wiring
1.21	Accelerator pedal out of range/open circuit/short circuit/plausibility error	Pedal disabled (if vehicle with DA and PS6 transmission); safe/limited mode transmission (if vehicle with AoP transmission)	Check that the pedal is calibrated; check that the pedal outputs are not out of range; check wiring
1.22	Inching pedal out of range/open circuit/short circuit/plausibility error	Transmission in safe/limited mode (if vehicle with AoP transmission)	Check that the pedal is calibrated; check that the pedal outputs are not out of range; check wiring
1.23	Incompatibility between tag ID and ID saved in the control unit BMS27	Only the error is displayed	Check that the sensor head reads the equipment tag; check that the tag has not been replaced; check that BMS27 control unit has not been replaced
1.24	The first and the second mechanical gear are both disengaged (only if software version from VCM to 0.4)	The first gear engaged is displayed	Check wiring

DISTRIBUTOR ERROR CODES			
ERROR CODE	DESCRIPTION	VEHICLE REACTION	CHECK
2.1	Open circuit deadman solenoid valve	All boom movements disabled	Check the solenoid resistance, check wiring
2.2	Open circuit joystick servo-control solenoid valve	Movements of hydraulically-controlled boom disabled	Check the solenoid resistance, check wiring
2.3	(Ground or positive) short circuit boom extension solenoid valve	Boom extension disabled	Check the solenoid resistance, check wiring
2.4	Open circuit boom extension solenoid valve	Boom extension does not work	Check the solenoid resistance, check wiring
2.5	Out of range boom extension solenoid valve feedback	Boom extension does not work correctly	Check the solenoid resistance, check wiring
2.6	(Ground or positive) short circuit boom retraction solenoid valve	Boom retraction disabled	Check the solenoid resistance, check wiring
2.7	Open circuit boom retraction solenoid valve	Boom retraction does not work	Check the solenoid resistance, check wiring
2.8	Out of range boom retraction solenoid valve feedback	Boom retraction does not work correctly	Check the solenoid resistance, check wiring
2.9	(Ground or positive) short circuit auxiliary A solenoid valve	Auxiliary A disabled	Check the solenoid resistance, check wiring
2.10	Open circuit auxiliary A solenoid valve	Auxiliary A does not work	Check the solenoid resistance, check wiring
2.11	Out of range auxiliary A solenoid valve feedback	Auxiliary A does not work correctly	Check the solenoid resistance, check wiring
2.12	(Ground or positive) short circuit auxiliary B solenoid valve	Auxiliary B disabled	Check the solenoid resistance, check wiring
2.13	Open circuit auxiliary B solenoid valve	Auxiliary B does not work	Check the solenoid resistance, check wiring
2.14	Out of range auxiliary B solenoid valve feedback	Auxiliary B does not work correctly	Check the solenoid resistance, check wiring
2.15	Open circuit boom lower slowing solenoid valve	Boom lower is always slow	Check the solenoid resistance, check wiring

TRANSMISSION AND STEERING WHEEL ERROR CODES			
ERROR CODE	DESCRIPTION	VEHICLE REACTION	CHECK
3.1	(Ground or positive) short circuit hydrostatic motor proportional solenoid valve	Current to hydrostatic pump solenoid valves reduced; hydrostatic motor disabled; transmission in safe/limited mode	Check the solenoid resistance, check wiring
3.2	Open circuit hydrostatic motor proportional solenoid valve	Current to hydrostatic pump solenoid valves reduced; hydrostatic motor does not work; transmission in safe/limited mode	Check the solenoid resistance, check wiring
3.3	Out of range hydrostatic motor proportional solenoid valve feedback	Current to hydrostatic pump solenoid valves reduced; hydrostatic motor does not work correctly; transmission in safe/limited mode	Check the solenoid resistance, check wiring
3.4	(Ground or chassis) short circuit hydrostatic pump forward gear proportional solenoid valve	Forward gear disabled	Check the solenoid resistance, check wiring
3.5	Open circuit hydrostatic pump forward gear proportional solenoid valve	Forward gear does not work	Check the solenoid resistance, check wiring
3.6	Out of range hydrostatic pump forward gear proportional solenoid valve feedback	Current to forward gear solenoid reduced; transmission in safe/limited mode	Check the solenoid resistance, check wiring
3.7	(Ground or chassis) short circuit hydrostatic pump reverse gear proportional solenoid valve	Reverse gear disabled	Check the solenoid resistance, check wiring
3.8	Open circuit hydrostatic pump reverse gear proportional solenoid valve	Reverse gear does not work	Check the solenoid resistance, check wiring
3.9	Out of range hydrostatic pump reverse gear proportional solenoid valve feedback	Current to reverse gear solenoid reduced; transmission in safe/limited mode	Check the solenoid resistance, check wiring
3.10	Rpm sensor failure on hydrostatic motor (only AoP transmission)	Currents to hydrostatic pump solenoid valves reduced; transmission in safe/limited mode	Check the sensor, check wiring
3.11	(Ground or positive) short circuit crab steering solenoid valve	If crab mode active: it remains always active (if to positive) or the detent keeps it active (if to ground); if crab mode not active: it can be accidentally activated or never activated	Check the solenoid resistance, check wiring
3.12	Open circuit crab steering solenoid valve	If crab mode active: the detent keeps it active; if crab mode not active: it does not activate	Check the solenoid resistance, check wiring

TRANSMISSION AND STEERING WHEEL ERROR CODES			
3.13	(Ground or positive) short circuit concentric steering solenoid valve	If conc. mode active: it remains always active (if to positive) or the detent keeps it active (if to ground); if conc. mode not active: it can be accidentally activated or never activated	Check the solenoid resistance, check wiring
3.14	Open circuit concentric steering solenoid valve	If concentric mode active: the detent keeps it active; if concentric mode not active: it does not activate	Check the solenoid resistance, check wiring
3.15	(Ground or positive) short circuit detent solenoid valve	Detent function disabled (if to ground) or steering may accidentally change (if to positive)	Check the solenoid resistance, check wiring
3.16	Open circuit detent solenoid valve	Detent function does not work, therefore the steering mode does not change	Check the solenoid resistance, check wiring
3.17	(Ground or positive) short circuit DA hydrostatic motor directional solenoid valve	Function disabled (if to ground) or always activated (if to positive)	Check the solenoid resistance, check wiring
3.18	DA hydrostatic motor directional solenoid valve Open circuit	Directional function does not work	Check the solenoid resistance, check wiring
3.19	Motor Brake Pressure Defeat solenoid valve (Ground or positive) short circuit Danfoss hydrostatic	Limited hydrostatic pump forward gear and reverse gear solenoid valves; Brake Pressure Defeat solenoid valve disabled (if to ground) or always active (if to positive); transmission in safe/limited mode	Check the solenoid resistance, check wiring
3.20	Open circuit Danfoss hydrostatic motor Brake Pressure Defeat solenoid valve	Limited hydrostatic pump forward gear and reverse gear solenoid valves; Brake Pressure Defeat solenoid valve does not work; transmission in safe/limited mode	Check the solenoid resistance, check wiring
3.21	(Ground or positive) short circuit parking brake solenoid valve	Parking brake always engaged (if to ground) or always released (if to positive)	Check the solenoid resistance, check wiring
3.22	Open circuit parking brake solenoid valve	Parking brake always engaged	Check the solenoid resistance, check wiring
3.23	Plausibility error parking brake solenoid valve (the brake state does not match the pressure switch information)	Parking brake does not work correctly	Check the solenoid resistance, check wiring
3.24	Out of range value movement pump pressure sensor (Agri Farmer and Icarus only)	Does not work	Check the sensor, check wiring

RFID ERROR CODES (equipment self-identification system)			
ERROR CODE	DESCRIPTION	VEHICLE REACTION	CHECK
4.1	Generic RFID error: antenna disabled, buffer overflow, reader error, reading error, writing error, TAG error	The vehicle automatically switches to forks mode	Check the reader; check the TAG, check wiring
4.2	The reader does not send messages on CAN BUS line (CAN Timeout)	The vehicle automatically switches to forks mode	Check the reader, check wiring

JOYSTICK ERROR CODES			
ERROR CODE	DESCRIPTION	VEHICLE REACTION	CHECK
5.1	The joystick does not send or receive messages on the line CAN BUS (CAN Timeout)	Joystick disabled	Check the joystick
5.2	The joystick does not send or receive messages on the CAN BUS line (CAN Timeout) but access to the memory is possible	Joystick disabled	Check the joystick
5.3	Tilting up/down: signal 1 out of range	Tilting disabled	Check if there is a drift in the relevant signal
5.4	Tilting up/down: signal 2 out of range	Tilting disabled	Check if there is a drift in the relevant signal
5.5	Tilting up/down: plausibility error (signals 1 and 2 are incompatible with each other)	Tilting disabled	Check both signals
5.6	Up/down movement: signal 1 out of range	Up/down movements disabled	Check if there is a drift in the relevant signal
5.7	Up/down movement: signal 2 out of range	Up/down movements disabled	Check if there is a drift in the relevant signal
5.8	Up/down movements: plausibility error (signals 1 and 2 are incompatible with each other)	Up/down movements disabled	Check both signals
5.9	Extension/retraction: signal 1 out of range	Extension/retraction disabled	Check if there is a drift in the relevant signal
5.10	Extension/retraction: signal 2 out of range	Extension/retraction disabled	Check if there is a drift in the relevant signal
5.11	Extension/retraction: plausibility error (signals 1 and 2 are incompatible with each other)	Extension/retraction disabled	Check both signals
5.12	Forward/backward gear roller: signal 1 out of range	Transmission does not work	Check if there is a drift in the relevant signal
5.13	Forward/backward gear roller: signal 2 out of range	Transmission does not work	Check if there is a drift in the relevant signal
5.14	Forward/backward gear roller: plausibility error (signals 1 and 2 are incompatible with each other)	Transmission does not work	Check both signals
5.15	Auxiliaries: signal 1 out of range	Auxiliaries do not work	Check if there is a drift in the relevant signal
5.16	Auxiliaries: signal 2 out of range	Auxiliaries do not work	Check if there is a drift in the relevant signal
5.17	Auxiliaries: plausibility error (signals 1 and 2 are incompatible with each other)	Auxiliaries do not work	Check both signals

JOYSTICK ERROR CODES			
5.18	Continuous oil key timeout	Continuous oil does not work	Check the key
5.19	Neutral N key timeout	Neutral disabled	Check the key
5.20	Top switch key timeout	Top switch function disabled	Check the key
5.21	Deadman key timeout	Deadman function disabled (no boom movements)	Check the key
5.22	Continuous oil function activated during engine start	Continuous oil disabled (does not work) until the key is released	Make sure that the key has not been accidentally activated, check the key
5.23	Top switch function activated during engine start	Top switch function disabled (does not work) until the key is released	Make sure that the key has not been accidentally activated, check the key
5.24	Deadman function activated during engine start	Deadman function disabled (does not work) until the key is released	Make sure that the key has not been accidentally activated, check the key
5.25	The joystick does not send the BJM signal (CAN Timeout)	Joystick disabled	Check joystick messages on CAN; check wiring
5.26	The joystick does not send the EJM signal (CAN Timeout)	Joystick disabled	Check joystick messages on CAN; check wiring

JOYSTICK ERROR CODES			
ERROR CODE	DESCRIPTION	VEHICLE REACTION	CHECK
6.1	Anti-tipping system: plausibility error	Boom functions disabled except retraction; the functions can be enabled again using the bypass key	Check the Liberty Link; check the VCM; check wiring
6.2	Load sensing system: plausibility error	Boom functions disabled except retraction; the functions can be enabled again using the bypass key	Check the Liberty Link; check M92; check wiring
6.3	The VCM control unit does not send the VCMTOLL message (0x18FF1021): CAN timeout		Check the Liberty Link; check the VCM; check wiring
6.4	Liberty Link (LL) control unit does not send message LLToVCM (0x18FF1102): CAN timeout		Check the Liberty Link; check the VCM; check wiring

BMS27 ERROR CODES (lifting equipment and baskets)			
ERROR CODE	DESCRIPTION	VEHICLE REACTION	CHECK
7.1	Load cell: plausibility error (signals 1 and 2 are incompatible with each other)	Boom functions disabled except retraction and auxiliary A (winch rope descent); the functions can be enabled again using the bypass key	Check the load cell; check that it is calibrated; check BMS27; check VCM; check wiring
7.2	Load cell: signal 1 out of range	Boom functions disabled except retraction and auxiliary A (winch rope descent); the functions can be enabled again using the bypass key	Check the load cell; check that it is calibrated; check BMS27; check signal drift; check wiring
7.3	Load cell: signal 2 out of range	Boom functions disabled except retraction and auxiliary A (winch rope descent); the functions can be enabled again using the bypass key	Check the load cell; check that it is calibrated; check BMS27; check signal drift; check wiring
7.4	Load cell not calibrated	Boom functions disabled except retraction and auxiliary A (winch rope descent); the functions can be enabled again using the bypass key	Check BMS27; calibrate
7.5	Linear joystick, signal out of range	Boom functions disabled	Check the joystick; check that the joystick is calibrated; check the signal drift; check BMS27; check wiring
7.6	Linear joystick activated upon start-up	Boom functions disabled until the joystick is released	Check that the joystick has not been accidentally activated, check that it is not locked, check wiring

BMS27 ERROR CODES (lifting equipment and baskets)			
7.7	Boom up/down movement selector activated upon start-up	Boom up/down movements disabled until the selector is released	Check that the selector has not been accidentally activated, check that it is not locked, check wiring
7.8	Boom extension/retraction selector activated upon start-up	Boom extension/retraction disabled until the selector is released	Check that the selector has not been accidentally activated, check that it is not locked, check wiring
7.9	Boom auxiliary selector activated upon start-up	Boom auxiliaries disabled until the selector is released	Check that the selector has not been accidentally activated, check that it is not locked, check wiring

VDC ERROR CODES (TERA7 display controller)			
ERROR CODE	DESCRIPTION	VEHICLE REACTION	CHECK
8.1	VDC does not send the VCMTOLL signal (0x184): CAN Timeout	VDC functions disabled	Check the VDC; check the VCM, check wiring
8.2	Central VDC key pressed upon start-up	Relevant VDC key disabled until it is released	Check that the key has not been accidentally activated, check that it is not locked, check wiring
8.3	MENU VDC key pressed upon start-up	Relevant VDC key disabled until it is released	Check that the key has not been accidentally activated, check that it is not locked, check wiring
8.4	ESC VDC key pressed upon start-up	Relevant VDC key disabled until it is released	Check that the key has not been accidentally activated, check that it is not locked, check wiring
8.5	Speed limitation VDC key pressed upon start-up	Relevant VDC key disabled until it is released	Check that the key has not been accidentally activated, check that it is not locked, check wiring
8.6	Manual accelerator VDC key pressed upon start-up	Relevant VDC key disabled until it is released	Check that the key has not been accidentally activated, check that it is not locked, check wiring
8.7	Drive mode VDC key pressed upon start-up	Relevant VDC key disabled until it is released	Check that the key has not been accidentally activated, check that it is not locked, check wiring

17.4 - BCM errors

VEHICLE ERROR CODES			
ERROR CODE	DESCRIPTION	VEHICLE REACTION	CHECK
1.1	SARL plausibility error; TippingAlarm1 and TippingAlarm2 signals are inconsistent	No boom movement, except retraction. All movements reactivate from bypass key	Check the correct operation of SARL (HD/SW); check wiring
1.2	Open circuit fan reversal solenoid valve	Fan reversal does not work	Check the solenoid resistance, check wiring
1.3	(Ground or positive) short circuit fan drive solenoid valve	Fan drive function disabled (if to ground) or unintentionally activated (if to positive)	Check the solenoid resistance, check wiring
1.4	Open circuit fan drive solenoid valve	Fan drive function does not work	Check the solenoid resistance, check wiring
1.5	Open circuit top switch 1 solenoid valve	Top switch 1 function does not work	Check the solenoid resistance, check wiring
1.6	(Ground or positive) short circuit top switch 2 solenoid valve	Top switch 2 function disabled (if to ground) or unintentionally activated (if to positive)	Check the solenoid resistance, check wiring
1.7	Open circuit top switch 2 solenoid valve	Top switch 2 function does not work	Check the solenoid resistance, check wiring
1.8	Plausibility error of overload system: OverloadAlarm1 (digital) and OverloadAlarm2 (CAN BUS) signals are inconsistent	No boom movement, except retraction and auxiliary A (if winch only). All movements reactivate from bypass/recovery key or during calibration	Check the correct operation of SARL unit (HD/SW); check wiring
1.9	Battery voltage out of range	Power from battery disabled (for vehicles with DA/PS6/DRC transmission); safe/limited mode transmission (for vehicles with AoP transmission)	Check wiring
1.10	Voltage of output 8 of VCM out of range	Power to sensor disabled (for vehicles with DA/PS6/DRC transmission); safe/limited mode transmission (for vehicles with AoP transmission)	Check wiring
1.11	RPM+ key (in the cab or on the remote control) activated during engine start	RPM+ function disabled until the key is released	Check that the key has not been accidentally activated, check the key, check wiring
1.12	RPM- key (in the cab or on the remote control) activated during engine start	RPM- function disabled until the key is released	Check that the key has not been accidentally activated, check the key, check wiring
1.13	Linear joystick EV1 (rear hydraulic socket) activated during engine start	EV1 function disabled until the key is released	Check that the linear joystick has not been accidentally activated, check the linear joystick, check wiring

VEHICLE ERROR CODES			
1.14	Linear joystick EV2 (rear hydraulic socket) activated during engine start	EV2 function disabled until the key is released	Check that the linear joystick has not been accidentally activated, check the linear joystick, check wiring
1.15	Linear joystick EV3 (rear hydraulic socket) activated during engine start	EV3 function disabled until the key is released	Check that the linear joystick has not been accidentally activated, check the linear joystick, check wiring
1.16	Linear joystick EV1 (rear hydraulic socket): value out of range	EV1 function disabled	Check minimum and maximum values at linear joystick output; check wiring
1.17	Linear joystick EV2 (rear hydraulic socket): value out of range	EV2 function disabled	Check minimum and maximum values at linear joystick output; check wiring
1.18	Linear joystick EV3 (rear hydraulic socket): value out of range	EV3 function disabled	Check minimum and maximum values at linear joystick output; check wiring
1.19	FNR column switch plausibility error	FNR column switch disabled: transmission does not work	Check the outputs from FNR column switch; check wiring
1.20	FNR column switch not in neutral during engine start	FNR column switch disabled: transmission does not work until the column switch is released	Check that FNR column switch has not been accidentally activated; check that FNR column switch is not locked in forward gear and reverse gear; check wiring
1.21	Accelerator pedal out of range/open circuit/short circuit/plausibility error	Pedal disabled (if vehicle with DA and PS6 transmission); safe/limited mode transmission (if vehicle with AoP transmission)	Check that the pedal is calibrated; check that the pedal outputs are not out of range; check wiring
1.22	Inching pedal out of range/open circuit/short circuit/plausibility error	Transmission in safe/limited mode (if vehicle with AoP transmission)	Check that the pedal is calibrated; check that the pedal outputs are not out of range; check wiring
1.23	Incompatibility between tag ID and ID saved in the control unit BMS27	Only the error is displayed	Check that the sensor head reads the equipment tag; check that the tag has not been replaced; check that BMS27 control unit has not been replaced
1.24	The first and the second mechanical gear are both disengaged (only if software version from VCM to 0.4)	The first gear engaged is displayed	Check wiring

HYDRAULIC DISTRIBUTOR ERROR CODES			
ERROR CODE	DESCRIPTION	VEHICLE REACTION	CHECK
2.1*	(Ground or positive) short circuit boom lower solenoid valve	Boom lower disabled by switching off proportional and venting solenoid valve	Check the solenoid resistance, check wiring
2.2*	Open circuit boom lower solenoid valve	Boom lower does not work	Check the solenoid resistance, check wiring
2.3*	Open circuit boom lower solenoid valve feedback	Boom lower does not work correctly	Check the solenoid resistance, check wiring
2.4*	Plausibility error boom lower solenoid valve: command and feedback not plausible	Boom lower disabled by switching off venting solenoid valve	Check wiring
2.5*	Plausibility error boom lower solenoid valve: not controlled but reel not in neutral	Boom lower disabled by switching off venting solenoid valve	Check the reel position; check wiring
2.6*	Plausibility error boom lower solenoid valve: controlled but reel in neutral	Boom lower disabled	Check the reel position; check wiring
2.7*	(Ground or positive) short circuit boom up solenoid valve	Boom up disabled by switching off proportional and venting solenoid valve	Check the solenoid resistance, check wiring
2.8*	Open circuit boom up solenoid valve	Boom up does not work	Check the solenoid resistance, check wiring
2.9*	Open circuit boom up solenoid valve feedback	Boom up does not work correctly	Check the solenoid resistance, check wiring
2.10*	Plausibility error boom up solenoid valve: command and feedback not plausible	Boom up disabled by switching off venting solenoid valve	Check wiring
2.11*	Plausibility error boom lower solenoid valve: not controlled but reel not in neutral	Boom up disabled by switching off venting solenoid valve	Check the reel position; check wiring
2.12*	Plausibility error boom up solenoid valve: controlled but reel in neutral	Boom up disabled	Check the reel position; check wiring
2.13*	(Ground or positive) short circuit boom extension solenoid valve	Boom extension disabled by switching off proportional and venting solenoid valve	Check the solenoid resistance, check wiring
2.14*	Open circuit boom extension solenoid valve	Boom extension does not work	Check the solenoid resistance, check wiring
2.15*	Open circuit boom extension solenoid valve feedback	Boom extension does not work correctly	Check the solenoid resistance, check wiring
2.16*	Plausibility error boom extension solenoid valve:	Boom extension disabled by switching off venting solenoid valve	Check wiring

HYDRAULIC DISTRIBUTOR ERROR CODES			
	command and feedback not plausible		
2.17*	Plausibility error boom extension solenoid valve: not controlled but reel not in neutral	Boom extension disabled by switching off venting solenoid valve	Check the reel position; check wiring
2.18*	Plausibility error boom extension solenoid valve: controlled but reel in neutral	Boom extension disabled	Check the reel position; check wiring
2.19*	(Ground or positive) short circuit boom retraction solenoid valve	Boom retraction disabled by switching off proportional and venting solenoid valve	Check the solenoid resistance, check wiring
2.20*	Open circuit boom retraction solenoid valve	Boom retraction does not work	Check the solenoid resistance, check wiring
2.21*	Open circuit boom retraction solenoid valve feedback	Boom retraction does not work correctly	Check the solenoid resistance, check wiring
2.22*	Plausibility error boom retraction solenoid valve: command and feedback not plausible	Boom retraction disabled by switching off venting solenoid valve	Check wiring
2.23*	Plausibility error boom retraction solenoid valve: not controlled but reel not in neutral	Boom retraction disabled by switching off venting solenoid valve	Check the reel position; check wiring
2.24*	Plausibility error boom retraction solenoid valve: controlled but reel in neutral	Boom retraction disabled	Check the reel position; check wiring
2.25*	(Ground or positive) short circuit tilting down solenoid valve	Tilting down disabled by switching off proportional and venting solenoid valve	Check the solenoid resistance, check wiring
2.26*	Open circuit tilting down solenoid valve	Tilting down does not work	Check the solenoid resistance, check wiring
2.27*	Open circuit tilting down solenoid valve feedback	Tilting down does not work correctly	Check the solenoid resistance, check wiring
2.28*	Plausibility error tilting down solenoid valve: command and feedback not plausible	Tilting down disabled by switching off venting solenoid valve	Check wiring
2.29*	Plausibility error tilting down solenoid valve: not controlled but reel not in neutral	Tilting down disabled by switching off venting solenoid valve	Check the reel position; check wiring
2.30*	Plausibility error tilting down solenoid valve: controlled but reel in neutral	Tilting down disabled	Check the reel position; check wiring

HYDRAULIC DISTRIBUTOR ERROR CODES			
2.31*	(Ground or positive) short circuit tilting up solenoid valve	Tilting up disabled by switching off proportional and venting solenoid valve	Check the solenoid resistance, check wiring
2.32*	Open circuit tilting up solenoid valve	Tilting up does not work	Check the solenoid resistance, check wiring
2.33*	Open circuit tilting up solenoid valve feedback	Tilting up does not work correctly	Check the solenoid resistance, check wiring
2.34*	Plausibility error tilting up solenoid valve: command and feedback not plausible	Tilting up disabled by switching off venting solenoid valve	Check wiring
2.35*	Plausibility error tilting up solenoid valve: not controlled but reel not in neutral	Tilting up disabled by switching off venting solenoid valve	Check the reel position; check wiring
2.36*	Plausibility error tilting up solenoid valve: controlled but reel in neutral	Tilting up disabled	Check the reel position; check wiring
2.37*	(Ground or positive) short circuit auxiliary A solenoid valve	Auxiliary A disabled by switching off proportional and venting solenoid valve	Check the solenoid resistance, check wiring
2.38*	Open circuit auxiliary A solenoid valve	Auxiliary A does not work	Check the solenoid resistance, check wiring
2.39*	Open circuit auxiliary A solenoid valve feedback	Auxiliary A does not work correctly	Check the solenoid resistance, check wiring
2.40*	Plausibility error auxiliary A solenoid valve: command and feedback not plausible	Auxiliary A disabled by switching off venting solenoid valve	Check wiring
2.41*	Plausibility error auxiliary A solenoid valve: not controlled but reel not in neutral	Auxiliary A disabled by switching off venting solenoid valve	Check the reel position; check wiring
2.42*	Plausibility error auxiliary A solenoid valve: controlled but reel in neutral	Auxiliary A disabled	Check the reel position; check wiring
2.43*	(Ground or positive) short circuit auxiliary B solenoid valve	Auxiliary B disabled by switching off proportional and venting solenoid valve	Check the solenoid resistance, check wiring
2.44*	Open circuit auxiliary B solenoid valve	Auxiliary B does not work	Check the solenoid resistance, check wiring
2.45*	Open circuit auxiliary B solenoid valve feedback	Auxiliary B does not work correctly	Check the solenoid resistance, check wiring
2.46*	Plausibility error auxiliary B solenoid valve: command and feedback not plausible	Auxiliary B disabled by switching off venting solenoid valve	Check wiring

HYDRAULIC DISTRIBUTOR ERROR CODES			
2.47*	Plausibility error auxiliary B solenoid valve: not controlled but reel not in neutral	Auxiliary B disabled by switching off venting solenoid valve	Check the reel position; check wiring
2.48*	Plausibility error auxiliary B solenoid valve: controlled but reel in neutral	Auxiliary B disabled	Check the reel position; check wiring
(*) Bucher distributor with PWM solenoid valve and passenger basket			
2.1**	(Ground) short circuit boom up/down movement solenoid valve	Boom up/down movement disabled by switching off proportional and venting solenoid valve	Check the solenoid resistance, check wiring
2.2**	Plausibility error boom up/down movement solenoid valve: command and feedback not plausible	Boom up/down movement disabled by switching off venting solenoid valve	Check wiring
2.3**	Plausibility error boom up/down movement solenoid valve: not controlled but reel not in neutral	Boom up/down movement disabled by switching off venting solenoid valve	Check the reel position; check wiring
2.4**	Plausibility error boom up/down movement solenoid valve: controlled but reel in neutral	Boom up/down movements disabled	Check the reel position; check wiring
2.5**	(Ground) short circuit boom extension/retraction solenoid valve	Boom extension/retraction disabled by switching off proportional and venting solenoid valve	Check the solenoid resistance, check wiring
2.6**	Plausibility error boom extension/retraction solenoid valve: command and feedback not plausible	Boom extension/retraction disabled by switching off venting solenoid valve	Check wiring
2.7**	Plausibility error boom extension/retraction solenoid valve: not controlled but reel not in neutral	Boom extension/retraction disabled by switching off venting solenoid valve	Check the reel position; check wiring
2.8**	Plausibility error boom extension/retraction solenoid valve: controlled but reel in neutral	Boom extension/retraction disabled	Check the reel position; check wiring
2.9**	(Ground) short circuit tilting solenoid valve	Tilting disabled by switching off proportional and venting solenoid valve	Check the solenoid resistance, check wiring
2.10**	Plausibility error tilting solenoid valve: command and feedback not plausible	Tilting disabled by switching off venting solenoid valve	Check wiring

HYDRAULIC DISTRIBUTOR ERROR CODES			
2.11*	Plausibility error tilting solenoid valve: not controlled but reel not in neutral	Tilting disabled by switching off venting solenoid valve	Check the reel position; check wiring
2.12**	Plausibility error tilting solenoid valve: controlled but reel in neutral	Tilting disabled	Check the reel position; check wiring
2.13**	(Ground) short circuit auxiliary solenoid valve	Auxiliary disabled by switching off proportional and venting solenoid valve	Check the solenoid resistance, check wiring
2.14**	Plausibility error auxiliary solenoid valve: command and feedback not plausible	Auxiliary disabled by switching off venting solenoid valve	Check wiring
2.15**	Plausibility error auxiliary solenoid valve: not controlled but reel not in neutral	Auxiliary disabled by switching off venting solenoid valve	Check the reel position; check wiring
2.16**	Plausibility error auxiliary solenoid valve: controlled but reel in neutral	Auxiliary disabled	Check the reel position; check wiring
(**) Danfoss distributor with PVG solenoid valves and passenger basket			

BOOM ANGLE AND EXTENSION SENSOR ERROR CODES			
ERROR CODE	DESCRIPTION	VEHICLE REACTION	CHECK
11.1	Angle and extension sensor does not send message 0x1B0: CAN Timeout	No boom functions in passenger basket mode. Some/all functions can be reactivated using the recovery key or during calibration	Check CAN BUS messages of the sensor; check wiring
11.2	Angle and extension sensor does not send message 0x1B1: CAN Timeout	No boom functions in passenger basket mode. Some/all functions can be reactivated using the recovery key or during calibration	Check CAN BUS messages of the sensor; check wiring
11.3	Boom angle: signal 1 out of range	No boom functions in passenger basket mode. Some/all functions can be reactivated using the recovery key or during calibration	Check drift of signal 1 (value too high or too low)
11.4	Boom angle: signal 2 out of range	No boom functions in passenger basket mode. Some/all functions can be reactivated using the recovery key or during calibration	Check drift of signal 2 (value too high or too low)
11.5	Boom length: signal 1 out of range	No boom functions in passenger basket mode. Some/all functions can be reactivated using the recovery key or during calibration	Check drift of signal 1 (value too high or too low)
11.6	Boom length: signal 2 out of range	No boom functions in passenger basket mode. Some/all functions can be reactivated using the recovery key or during calibration	Check drift of signal 2 (value too high or too low)
11.7	Plausibility error boom angle: signals 1 and 2 are not consistent	No boom functions in passenger basket mode. Some/all functions can be reactivated using the recovery key or during calibration	Check both signals
11.8	Plausibility error boom length: signals 1 and 2 are not consistent	No boom functions in passenger basket mode. Some/all functions can be reactivated using the recovery key or during calibration	Check both signals
11.9	Generic error (internal failure of boom angle and extension sensor)	No boom functions in passenger basket mode. Some/all functions can be reactivated using the recovery key or during calibration	Check boom angle and extension sensor
11.13	Communication error: CAN RX overflow, PDO not processed	No boom functions in passenger basket mode. Some/all functions can be reactivated using the recovery key or during calibration	Check boom angle and extension sensor
11.16	Manufacturer error: wire broken, length reading error, Hall sensor reading error	No boom functions in passenger basket mode. Some/all functions can be reactivated using the recovery key or during calibration	Check boom angle and extension sensor

LEVELNESS SENSOR ERROR CODES			
ERROR CODE	DESCRIPTION	VEHICLE REACTION	CHECK
12.1	Levelness sensor does not send message 0x196: CAN Timeout	No boom functions in passenger basket mode. Some/all functions can be reactivated using the recovery key or during calibration	Check CAN BUS messages of the sensor; check wiring
12.9	Generic error (internal failure of levelness sensor)	No boom functions in passenger basket mode. Some/all functions can be reactivated using the recovery key or during calibration	Check the levelness sensor
12.13	Communication error: CAN RX overflow, PDO not processed	No boom functions in passenger basket mode. Some/all functions can be reactivated using the recovery key or during calibration	Check the levelness sensor

REMOTE CONTROL ERROR CODES			
ERROR CODE	DESCRIPTION	VEHICLE REACTION	CHECK
13.1	The remote control does not send message 0x18A: CAN Timeout	Remote control disabled (keys and levers): boom movements and accelerator disabled	Check CAN BUS messages of the remote control; check wiring
13.2	The remote control does not send message 0x28A: CAN Timeout	Remote control disabled (levers): boom movements disabled	Check CAN BUS messages of the remote control; check wiring
13.3	Remote control boom up/down movement lever activated upon start-up	Movement disabled until the lever is released	Check that the lever has not been accidentally activated, check that it is not locked, check wiring
13.4	Remote control boom extension/retraction movement lever activated upon start-up	Movement disabled until the lever is released	Check that the lever has not been accidentally activated, check that it is not locked, check wiring
13.5	Remote control boom auxiliary lever activated upon start-up	Movement disabled until the lever is released	Check that the lever has not been accidentally activated, check that it is not locked, check wiring
13.6	Remote control tilting up/down movement lever activated upon start-up	Movement disabled until the lever is released	Check that the lever has not been accidentally activated, check that it is not locked, check wiring
13.7	Deadman switch (at least one) activated upon start-up	Boom movements disabled until the switch is released	Check that the switch has not been accidentally activated, check that it is not locked, check wiring
13.8	Auxiliary switch activated upon start-up	Top switch disabled until the switch is released	Check that the switch has not been accidentally activated, check that it is not locked, check wiring
13.9	Generic error (internal failure detected by the remote control)	Remote control disabled (keys and levers): boom movements and accelerator disabled	Check the remote control
13.10	Current error (internal failure detected by the remote control)	Remote control disabled (keys and levers): boom movements and accelerator disabled	Check the remote control
13.11	Voltage error (internal failure detected by the remote control)	Remote control disabled (keys and levers): boom movements and accelerator disabled	Check the remote control
13.12	Temperature error (internal failure detected by the remote control)	Remote control disabled (keys and levers): boom movements and accelerator disabled	Check the remote control
13.13	Communication error (internal failure detected by the remote control)	Remote control disabled (keys and levers): boom movements and accelerator disabled	Check the remote control
13.14	Device error (internal failure detected by the remote control)	Remote control disabled (keys and levers): boom movements and accelerator disabled	Check the remote control

REMOTE CONTROL ERROR CODES			
13.15	Specific manufacturer error (internal failure detected by the remote control)	Remote control disabled (keys and levers): boom movements and accelerator disabled	Check the remote control

Cleaning the vehicle and all its components is fundamental for it to be kept in proper working order.

18.1 - Vehicle cleaning

Proceed as follows for a correct cleaning process:

- Switch the engine off, remove the ignition key and wait until the various components cool down.
- Wear the suitable protective clothing (gloves, masks, overalls, etc.).
- Do not use flammable liquids, acids or products that may chemically attack the vehicle components.
- Use water to soften dirt that sticks to the surface.
- Ask your **DIECI** dealer for touch-up paint to repair minor defects in the vehicle bodywork.
- Check that all the safety stickers are present. Replace any that have been lost or removed for cleaning purposes.
- Use a pressure washer to clean the external part of the vehicle and the engine compartment, bearing the following in mind:
 - Make sure the top-up caps (radiator, oil tank, fuel tank, etc.) are closed well.
 - Protect the control boxes and connectors from water infiltrations.
 - Do not operate with a pressure and water temperature that exceeds 100 bar and 80°, respectively.
 - Hold the washer nozzle at a minimum distance of 40 cm from the relative surface.
 - Do not direct the jet at any single point but wash with wide strokes.
 - The inside of the vehicle is delicate and cannot be cleaned with a pressure washer.

Electrical components

- If a pressurized jet is used, try not to wet the electrical components, such as the alternator and the starter motor.
- If water accidentally falls into the electrical system, it could cause the vehicle to malfunction.
- Do not use water or steam to clean the electrical system, sensors and connectors.

Mechanical Components

- Do not clean the moving elements or hot surfaces, allow all parts to cool as a temperature change could damage them.

18.2 - Glasses cleaning

- The cab windows, lights and wing mirrors must be washed often with soapy water.
- After washing has been completed, dry thoroughly; do not leave any stains or marks which may limit or obstruct the driver's visibility.

18.3 - Cleaning the cab

- Clean soft upholstery in the cab with a cloth that has been dipped in a solution of water and detergent and then thoroughly wrung.
- The driver's seat and the floor must be cleaned with a vacuum cleaner and/or a stiff brush. If necessary, use a damp cloth to remove any stubborn stains.
- Clean the seat belt with a sponge that has been soaked in hot soapy water, and let it dry on its own.
- Fabric-covered seats must be cleaned with a stiff brush or vacuum cleaner. Plastic seats must be cleaned with a damp cloth.



WARNING

Pay attention to electrical components.

Do not use water jets inside the cab.



WARNING

Do not use products containing alcohol to clean the interior lining of the cab.

18.4 - Safety stickers cleaning



ATTENTION

To ensure proper interpretation verify that they are in the correct position and that they are always kept clean.

Clean the safety stickers when they are dirty, covered with mud, concrete or debris.



WARNING

It is absolutely forbidden to clean the messages on the vehicle and equipment using solvents or gasoline.

The labels may become discolored. The labels in addition to those of care and safety must always be treated in the same way.



DANGER

Always check the good condition of the anchors (ropes, chains, wedges, etc...).

Make sure that the lifting equipment is adequate for the weight of the vehicle to be lifted.

NOTE! The weight and dimensions of the vehicle are shown in the “Technical data” chapter; check the overall dimensions for the maximum and minimum height values from the ground and the weight allowed.

The vehicle is fitted with lifting points, marked by special symbols (fig. 150522-1).

Attach the ropes at the points indicated in the figure, paying utmost attention during the lifting phases. Slowly proceed with the lifting.

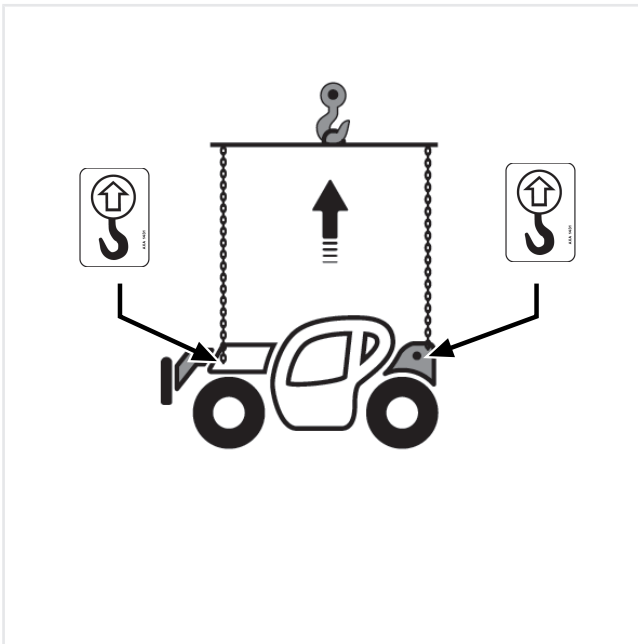

Figure: 150522-1

- Retract and lower the telescopic boom completely.
- Engage the parking brake, place and the movement selection lever at “N” and switch off the vehicle.
- Close all windows and the cab door.



DANGER

Before lifting the vehicle, make sure no unauthorized personnel are in the surrounding area.



ATTENTION

Lifting cables with a minimum unit capacity of 6 tons (13220 lb) are required.

Before lifting the vehicle, make sure to:

- Remove any attachments installed on the vehicle.



WARNING

Always check the good condition of the anchors (ropes, chains, wedges, etc...).

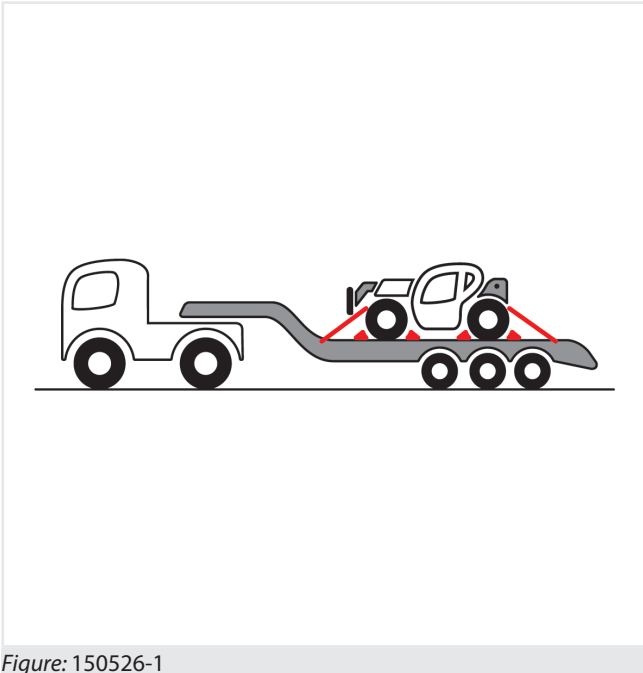

Figure: 150526-1

NOTE! The weight and dimensions of the vehicle are shown in the “Technical data” chapter; check the overall dimensions for the maximum and minimum height values from the ground and the weight allowed.

Pay attention to the following when loading the vehicle onto a trailer:

- Before using ramps or trailers to load the vehicle on, remove any mud, ice or oil that could cause accidents.
- Check that the axle and the transport vehicle can withstand the overall weight of the vehicle and any loaded equipment.
- Check the overall dimensions of the vehicle for minimum and maximum heights from the ground and the weight allowed.
- Carefully handle the vehicle onto the transport vehicle.
- Make sure local regulations are observed when transporting the vehicle on public roads.



DANGER

When loading or unloading a vehicle from a transport vehicle, there is always the risk of the vehicle overturning sideways; therefore, have another person on the ground to control the operations.

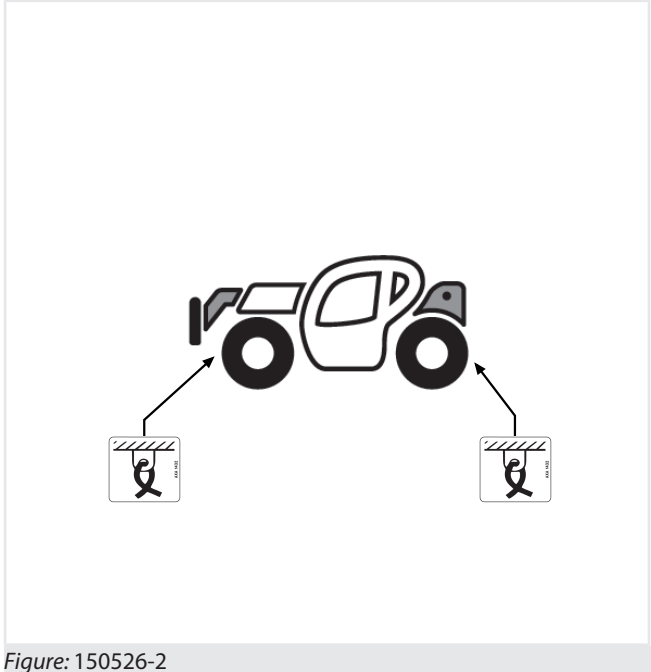

Figure: 150526-2

Take the following precautions when loading or unloading a vehicle:

1. Choose solid and level ground.
2. Remove any attachments installed on the vehicle.
3. Lower and fully retract the telescopic boom
4. Use a platform or a ramp.
5. Always select the slowest speed.
6. Load the vehicle on to the transport vehicle, making sure that the ramps are positioned properly and safely.
7. Once the vehicle is in a safe position, switch the engine off and engage the parking brake.
8. Close all windows and the cab door.
9. Anchor the vehicle to the transport vehicle with chains or cables through the relative hooks (fig. 150526-2).
10. Apply wedges to the front and rear wheels of the transport vehicle.

21.1 - Long period of inactivity

If the vehicle must be stored for a long period of time (over a week), certain precautions must be complied with to protect it:

- Clean the vehicle.
- Lubricate all the lubricators.
- Check the tires and inflate them to the recommended pressure.
- Clean the fuel system and change the filter cartridges.
- Store any equipment.
- Use the battery isolation switch to deactivate the electrical circuit.
- Realign and lower all the mobile parts of the vehicle completely.
- Close and lock all the windows.
- Close and lock the door.

21.2 - Long period of inactivity

If the vehicle must be stored for a long period (more than two months), certain precautions must be complied with to protect it:

- Clean the vehicle.
- Touch up the paint where necessary to prevent rust.
- Lubricate all the lubricators.
- Check whether any parts are worn or damaged and replace them, if necessary.
- Check the tires and inflate them to the recommended pressure.
- Drain the oil from the engine and replace it with new oil.
- Clean the fuel system and change the filter cartridges.
- Empty the fuel tank as usual and fill it with ten liters of special fuel for prolonged inactivity. Run the engine for ten minutes so the new solution can distribute evenly.
- Store any equipment.
- Use the battery isolation switch to deactivate the electrical circuit.
- Realign and lower all the mobile parts of the vehicle completely.
- Apply a layer of light grease on the uncovered rods of the hydraulic cylinders.
- Cover the exhaust opening.
- Close and lock all the windows.

- Close and lock the door.

21.3 - Restarting the vehicle

Preparing the vehicle after a long period of inactivity:

- Inflate the tires to the correct pressure.
- Remove the jack stands from under the axles.
- Fill the fuel tank.
- Check the radiator coolant level.
- Check the level of the various oils.
- Fit a fully charged battery.
- Remove the cover of the exhaust pipe.
- Remove the layer of grease on the exposed cylinder rods.
- Start the engine and check that all the controls work properly.
- Let the engine run for a few minutes.
- Verify the efficiency of the brake system.

- Waste material should not be dispersed in the environment but rather disposed of appropriately. Used lubricants, batteries, rags dirty with grease, brake pads etc. should be handed over to specialized companies authorized to dispose of polluting waste.
- Improper waste disposal poses a threat to the environment. The following are potentially dangerous waste: lubricants, fuel, cooling, filters and batteries.
- Do not spill or pour waste onto the ground, into the sewers or into water beds.
- Contact your local authority or collection centers for information for how to recycle or dispose of waste properly.

22.1 - Ecological considerations

A few helpful recommendations are listed below. Learn about current legislation in force in your country.

Ask suppliers for information about lubricating oils, fuels, antifreeze products, detergents, etc., about their effects on people and on the environment as well as on information regarding the regulations to be observed when using, stocking and disposing of such products.

- Do not refill the tanks using unsuitable jerry cans or pressurized combustible fueling systems as they may cause leaks and loss of significant amounts of liquid.
- Modern lubricating oils contain additives. Do not burn contaminated combustible oils and/or oils used in conventional heating systems.
- Take care not to spill used engine cooling fluids, engine and transmission lubricating oils, hydraulic oil, brake oil etc. while pouring or draining them. Store them safely and, when it is time, dispose of them in compliance with current legislation or with local facilities.
- Modern antifreeze liquids and their solutions, such as antifreeze and other additives should be replaced every two years. Make sure such liquids are not absorbed by the soil; they should be collected and disposed of appropriately.
- Do not intervene directly with the air conditioning systems (Optional), by opening them. These systems contain gas which must not be released into the atmosphere. Contact your dealer or an expert who has the necessary special equipment and who would, in any case, have to refill the system.
- Immediately repair any leaks or faults in the cooling or engine hydraulic systems.

22.2 - Protect the environment

It is illegal to pollute sewers, water sources or soil. Use only authorized dumping grounds centers, including the areas designated by the local authorities or workshops equipped with the necessary tools for the disposal of used oils. If in doubt, contact your local authority for relevant instructions.

To demolish the vehicle or the equipment, dismantle all components and keep the different types of materials separate for sending to the relative collection centers.

The following types of materials may be present:

- Ferrous materials (carpentries and mechanical components)
- Plastic materials (gaskets, belts, protections)
- Electric materials (cables, windings and similar)
- Oils and lubricants (hydraulic oil, reduction gear lubricants, lubricating greases)

24.1 - Components legend

Name	Sheet	Function
A134	15	Inv. control unit Condenser fans
A201	1	Basket control unit (Danfoss MC050)
A219	15	A/C Control unit
A241	1	SARL control unit
A670	1	Vehicle control unit (Danfoss MC050)
B1	1	Battery
B130	11	Seat microswitch
B139	12	Stop lights microswitch
B192	11	Brakes oil level
B205	15	Air conditioning system pressure switch
B400	14	Door microswitch
B504	10	Left front lowered outrigger microswitch
B512	11	Diesel fuel float
B513	11	Hydraulic oil filter pressure switch
B534	5	Engaged gear microswitch
B535	11	2nd engaged gear pressure switch
B542	11	Servo brake accumulator pressure switch
B550	10	Right front lowered outrigger microswitch
B554	11	Negative brake pressure switch
B558	6	Front axle alignment proxy
B559	3	Load cell
B560	6	Rear axle alignment proxy
B583	2	Scr of delta pressure sensor
B602	10	Left front closed outrigger microswitch
B603	10	Right front closed outrigger microswitch
B616	8	Levelness sensor
B634	15	Transmission oil radiator thermistor
B638	2	Air filter clogged
B642	15	Engine H2O radiator thermistor
B643	6	Closed boom microswitch
B680	2	UREA heating SV
B682	2	Temperature sensor downstream the catalyst
B683	4	SCR downstream Nox sensor w/ECU
B684	2	Temperature sensor upstream the catalyst
B686	2	Humidity sensor
B688	2	Diesel decanting sensor
B706	5	Brake pedal
B728	8	Extension angle sensor
B746	11	Air flow sensor
B778	11	Hydrostatic motor pressure and temperature sensor
B842	2	Doc upstream temperature sensor
B843	4	Urea quality sensor

Name	Sheet	Function
B844	4	DOC upstream Nox sensor w/ECU
B849	2	Doc downstream temperature sensor
B854	15	Boom oil radiator thermistor
B905	11	Transmission oil radiator thermostat
B909	11	Hydraulic oil filter pressure switch 2
B999	17	Hydraulic brake pressure switch
C1	3	Condenser
RH	16	Right rear headlight (optional)
E102	14	Right front work light
E103	14	Right rear work light
E104	14	Left front work light
E118	14	Left rear work light
E147	14	Overhead Light
E224	12	Pressure gauge lighting
E240.1	11	Red ARB warning light
E240.2	11	Yellow ARB warning light
E240.3	11	Watchdog warning light
E277	14	Left rear perimeter light
E328	14	IVECO M warning lights
E375	14	Starled footboard lighting bar
E524	12	Plate light
E727	9	Rotating light remote control
E819	14	Boom work light
E832	14	Starled ladder lighting bar
E910	14	Perimeter work light 1
E911	14	Perimeter work light 2
E96	13	Rotating light
F1	14	Rear work lights fuse
F11	5	Fuse +15 services - parking brake
F12	5	Fuse +15 services - cab controls
F13	11	Fuse +15 services - internal lighting
F130	2	Fuse +30 battery
F14	11	Fuse +15 services- sensors
F140	1	Electronic battery isolator fuse
F15	6	Fuse +15 serv. - levelling
F16	6	Fuse +15 services- Pneumatic seat
F17	14	Fuse +15 services - electrical and optional contact switch
F18	14	Fuse +15 services - electric window
F184	15	Heating selector fuse
F19	6	Fuse +15 services - rear SV + trailer
F2	14	Front work lights fuse
F20	17	Liberty link fuse
F21	1	Fuse +15/54 key - Radio switch

Name	Sheet	Function
F22	1	Fuse +15 key - Ign. DANA / Alternator
F23	1	Optional fuse
F24	1	Fuse +15/54 key - Starter anti-restart/cab mushroom-head pushbutton
F25	14	Boom head work light relay
F26	13	Fuse +15 services + rotating light switch
F27	1	Fuse +15 services- SAR control unit
F28	14	Fuse +15 services - Mirrors/radio adjustment
F29	13	Fuse +15 services - Front wiper
F3	13	Fuse +30 - Redundant ALGA instrument
F30	13	Fuse +15 services - Perimeter lights
F31	13	Fuse +15 services - rear-lateral wipers
F32	12	Fuse +15 services - Brake lights microswitch
F33	12	Front sidelights fuse Right + Rear Left
F34	12	Front sidelights fuse Left + Rear Right
F35	14	Fuse +30 - overhead light, radio and lights switch, combination light
F36	16	Fuse +30 gps kit and immobilizer
F37	12	Reverse gear light/ buzzer fuse
F38	7	Aux pump fuse
F39	1	Supply fuse Udc1 Danfoss
F391	16	Wireless lubricator fuse
F392	1	Fuse +50 start from panel
F393	1	Fuse +30 compressor relay
F394	15	Fuse +15 compressor and heating
F395	11	Fuse + 15 ALGA redundant services
F396	15	A/C condensate 1A solenoid valve fuse
F397	15	A/C condensate 2A solenoid valve fuse
F398	17	Fuse not used
F4	6	Outriggers consent fuse
F40	12	Low beam lights fuse
F41	5	Fuse +30 - Brake pedal pressure switch
F42	12	High beam lights fuse
F43	12	Horn fuse
F44	12	Fuse +30 - warning
F5	14	Fuse +30 - Heated mirrors
F50	1	Fuse VP ECU vehicle/basket
F51	15	Evaporator fan fuse
F541	1	Cab general fuse
F7	5	Pneumatic braking SV. fuse
F755	1	Cab general fuse
F8	14	Fuse +30 - Power socket
F858	1	Fuse +30 starter panel
F9	3	Fuse +30 - FPT diagnostics/ALGA instrument
FA10	2	ECU power supply fuse

Name	Sheet	Function
FA4	2	Start control fuse
FA5	2	Sensor power supply relay fuse
FA6	2	Diesel filter pre-heating relay fuse
FA7	4	Fuse +30 rotating light switch
FA8	2	FTP sensors fuse
FA9	2	Exhaust flap fuse
FG1	1	Alternator fuse
FG2	1	Pre-heating relay fuse
G529	1	Alternator
K1	6	Outriggers consent relay
K10	1	Temp. Micro seat/Starter anti-restart
K11	6	Arm relay 30°/S. cut-off 1 from SARL
K13	1	Service consent relay/engine stop command
K15	5	Relay +15 services - parking brake
K153	1	Services relay
K16	6	Distributor SV relay
K17	5	FNR SV relay
K18	12	Low beam lights relay
K19	12	Horn relay
K2	14	Front work light relay
K20	12	High beam lights relay
K21	12	Reverse gear light / buzzer relay
K22	14	Boom head work light relay
K23	12	Relay +15 services - Brake lights microswitch
K24	7	Aux pump relay
K25	1	Supply relay Udc1 Danfoss
K265	12	Direction indicators intermittent
K27	14	Brake lights relay
K28	3	Hydraulic power SV reduction relay
K29	6	Relay +15 serv. - levelling
K3	14	LH-RH heated mirrors relays
K30	6	Low boom NC S. relay
K31	14	Overhead light relay
K4	5	Trailer brake SV relay
K5	14	Rear work lights relay
K530	2	Starter motor relay
K531	2	Diesel filter pre-heating relay
K547	1	Air preheating relay
K6	5	Pneumatic braking SV relay
K672	2	Sensor power supply relay
K8	13	Engine stop control relay/Emerg. Mushroom-head button Basket
K829	2	Start consent relay
K830	2	ECU relay

Name	Sheet	Function
K9	15	AC compressor temp
M112	13	Front window wiper
M117	13	Front window washer
M119	13	Rear window washer
M122	13	Rear window wiper
M129	15	Heating motor
M133	15	Condenser fan 1
M152	6	Pneumatic seat
M195	15	Condenser fan 2
M378	13	Lateral window wiper
M405	13	Lateral window washer
M410	14	Electric window motor
M520	1	Starter motor
M555	15	A/C compressor
M641	15	Radiator double speed fan
P101	1	AL-GA Agri Sar tool
P149	14	Left speaker
P150	14	Right speaker
P216	11	ARB Buzzer
P502	12	Reverse gear buzzer
P503	12	Horn
P864	2	After treatment warning light
Q220	6	Joystick servo-controls SV
Q420	15	Trailer solenoid valve
Q489	7	Aux pump Sv.
Q507	10	Right front outrigger lowering SV
Q508	10	Left front outrigger lifting solenoid valve
Q509	10	Left front outrigger lowering solenoid valve
Q514	10	Outrigger general solenoid valve
Q515	10	Right front outrigger lifting SV
Q516	5	1st mechanical gear SV
Q518	10	Left levelling SV
Q518.	10	Left levelling SV
Q519	10	Right levelling SV
Q519.	10	Right levelling SV
Q521	5	2nd manual gear solenoid valve
Q523	5	Parking brake solenoid valve
Q527	5	Forward gear solenoid valve
Q528	5	Reverse gear solenoid valve
Q618	17	Hammer solenoid valve
Q705	17	Boom suspension solenoid valve
Q711	9	Directional service
Q712	9	Boom up/down movement SV

Name	Sheet	Function
Q713	9	Boom up/down movement directional
Q714	9	Tilting up/down SV
Q715	9	Tilting up/down directional
Q716	9	Services SV
Q717	9	Boom extension / retraction directional
Q725	8	Cut-off solenoid valve 1
Q725	9	Cut-off solenoid valve 1
Q765	8	PWM A boom extension
Q766	8	PWM B boom extension
Q767	8	PWM A AUX/Service
Q768	8	PWM B AUX/Service
Q789	9	Boom extension/retraction SV
Q829	17	Rear SV 1
Q830	17	Rear SV 2
Q833	17	Hydr. brake solenoid valve
Q871	17	Rear SV 3
Q881	6	Inching SV
Q929	8	Boom lower slowing solenoid valve
R0	1	Filter pre-heater
R1	3	Heating element
R127	14	Heated rear window
R138	5	Inching pedal sensor
R2	3	Heating element
R233	5	Accelerator pedal
R2A	16	Inductance
R2A	16	Inductance
R4	3	Heating element
R423	8	CAN OPEN end of line heating element
R5	3	Heating element
R533	2	Diesel filter heater
R837	17	Right mirror heating
R981	10	Left levelling 6A diode
R982	10	Right levelling 6A diode
R983	10	General levelling 6A diode
S0	1	El. battery isolator
S105	6	Outriggers consent button
S106	13	Rear work lights switch
S108	12	Warning switch
S109	7	Levelling button
S110A	5	Mechanical gear shift button
S110B	5	Max Vg switch
S113	6	Left front outrigger
S114	6	Right front outrigger

Name	Sheet	Function
S115	13	Rotating light switch
S120	13	Rear window wiper and washer switch
S121	5	Parking brake switch
S126	15	Fan speed selector
S131	17	Rear SV selector
S132	6	Trailer button
S136A	6	Wheels alignment button
S136B	6	Electric steering reset
S137	5	Gear switch
S140	12	Lights column switch
S141	1	Starter panel
S143	13	Remote Control Switch
S146	1	Unstable key for operations restoring
S148	13	Front work lights switch
S169	6	Boom suspension switch
S171	15	Fan reversing button
S202	17	Steering selector
S204	1	Cab mushroom-head emergency pushbutton
S206	13	Boom work light switch
S227	5	Accelerator switch
S228	5	Trailer brake SV button
S235	14	Perimeter headlight switch
S246	14	Mirror heating switch
S281	14	Electric mirror adjustment selector
S295	1	FTP regeneration inhibit switch
S303	6	Quick coupling button
S326	5	Eco/Normal switch
S329	1	Regeneration request button
S364	13	Wiper-washer switch on boom side
S376	15	Frost protection thermostat sensor
S411	14	Electric window button
S421	15	Front pressure relief button
S611	3	Cab joystick
S828	2	Recovery button
S836	1	Battery disconnecter
S918	14	Electrical contact switch
S919	1	Basket recovery key selector
LEFT	16	Left rear light (optional)
SXA	16	Rear left light
W151	14	Radio
X165	14	Electrical socket
X263	3	Multilink 2
X283	3	Multilink 1

Name	Sheet	Function
X685	2	Dosing urea connector
X762	6	
X838	17	Right mirror movement and heating
XDA	16	Rear right light
	12	Lights switch

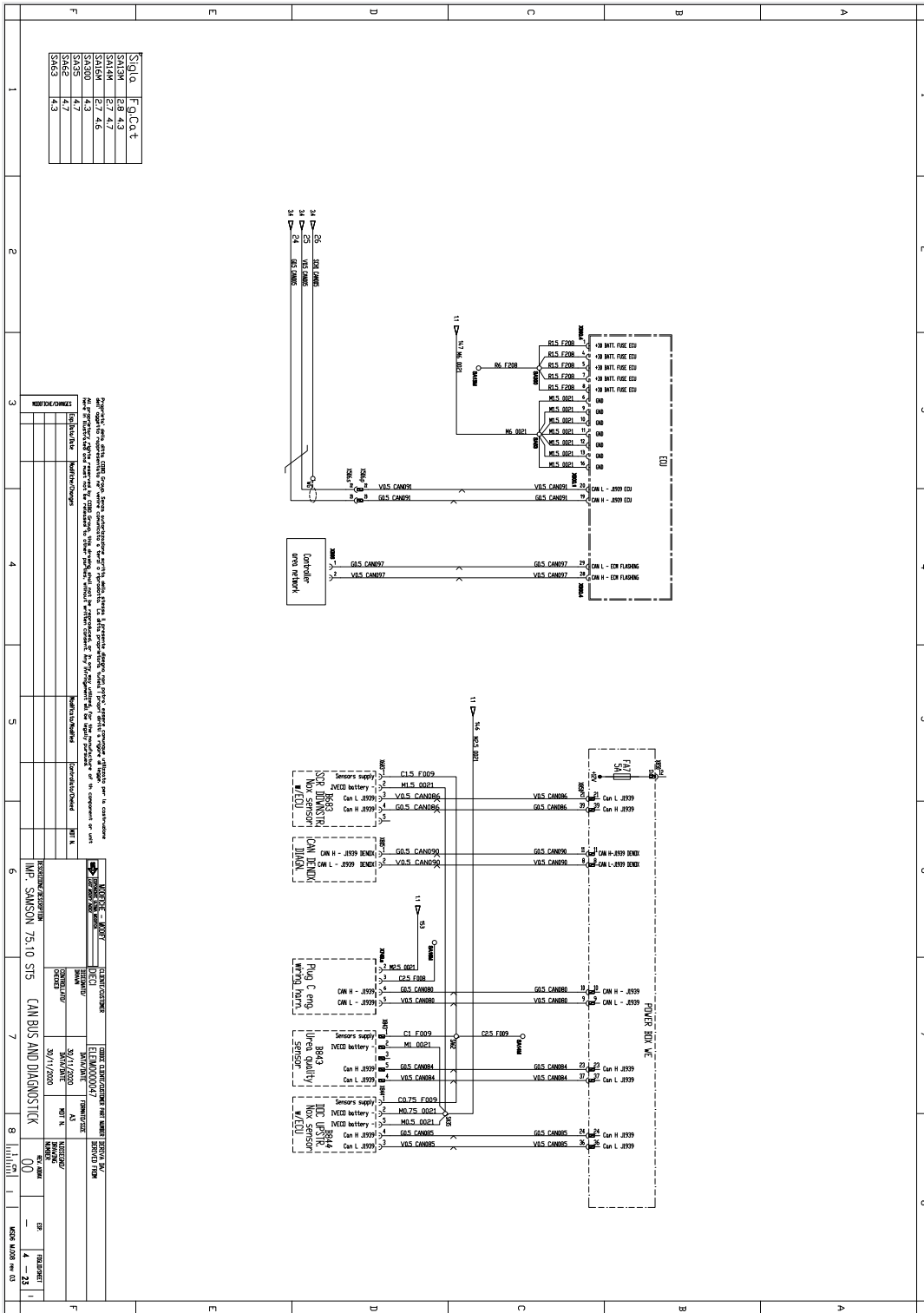

Figure: Wiring diagram 04

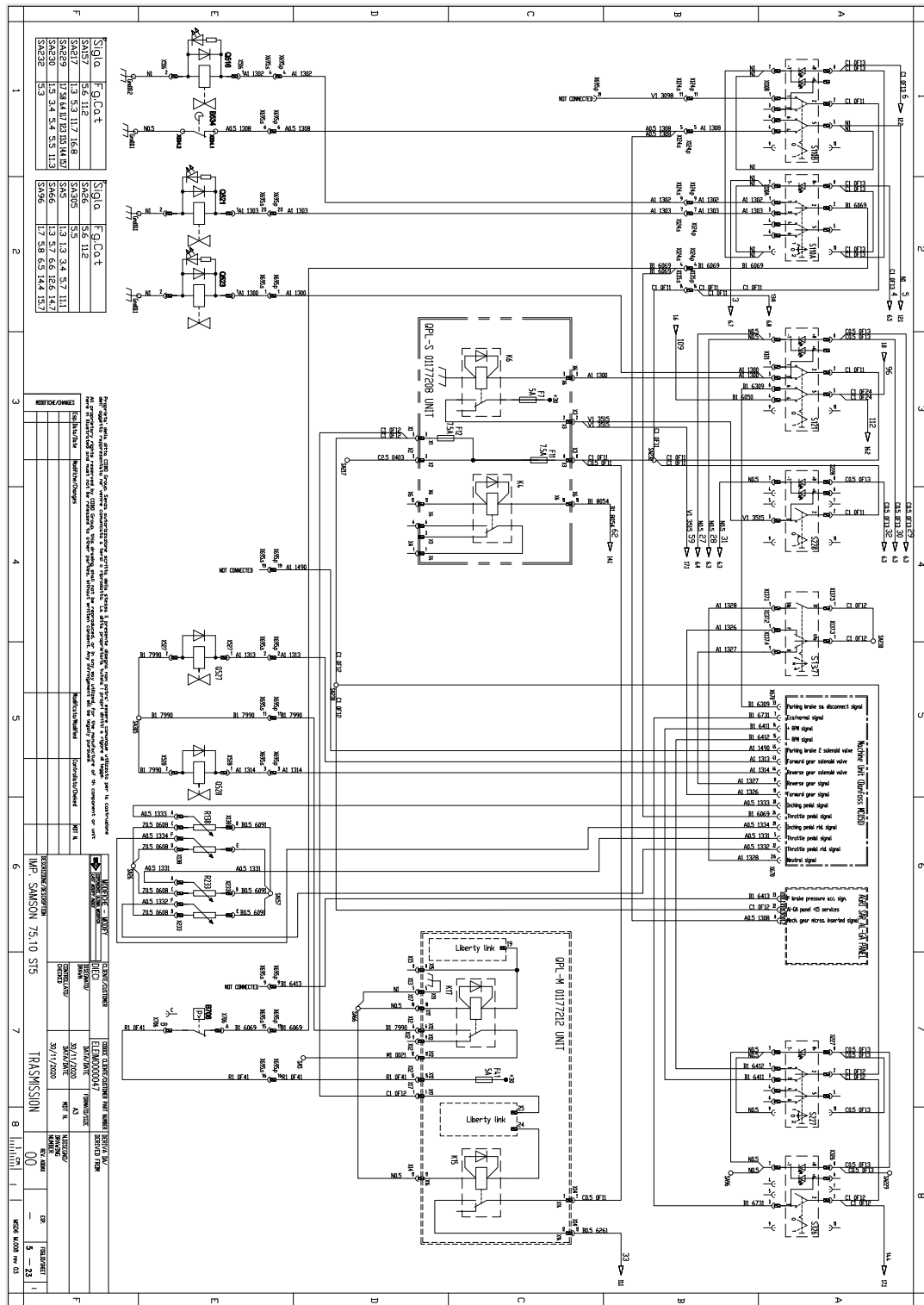

Figure: Wiring diagram 05

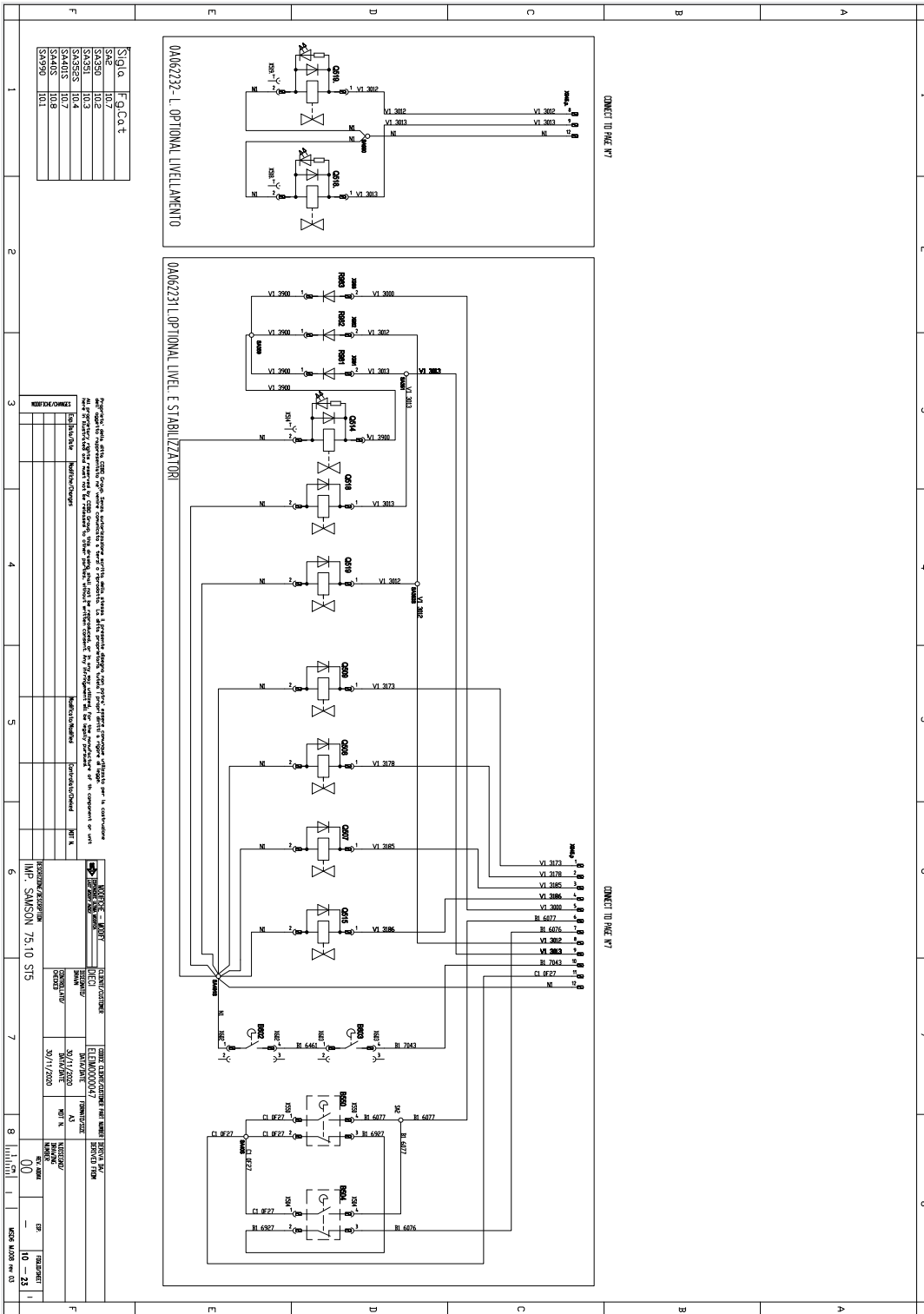

Figure: Wiring diagram 10

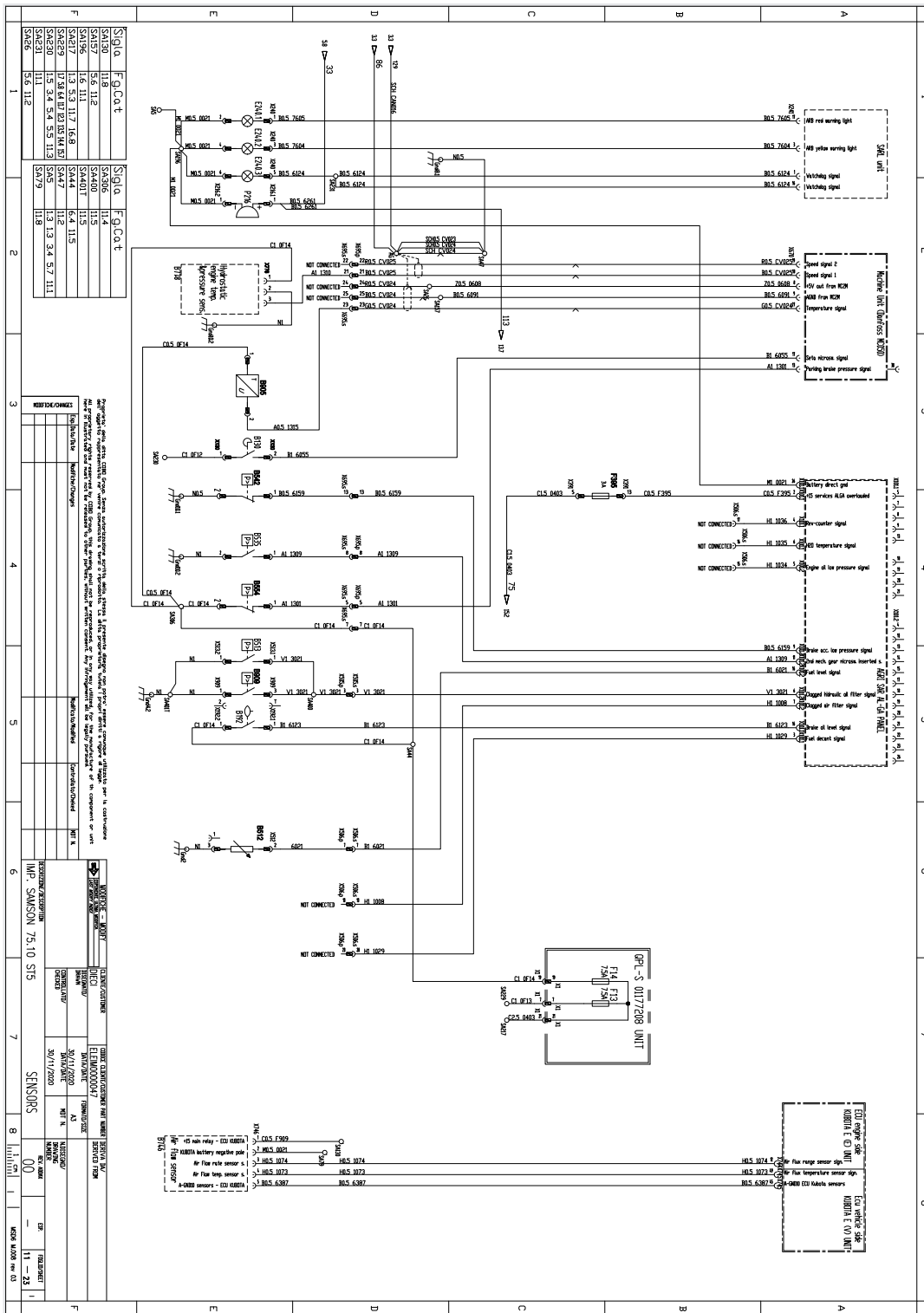

Figure: Wiring diagram 11

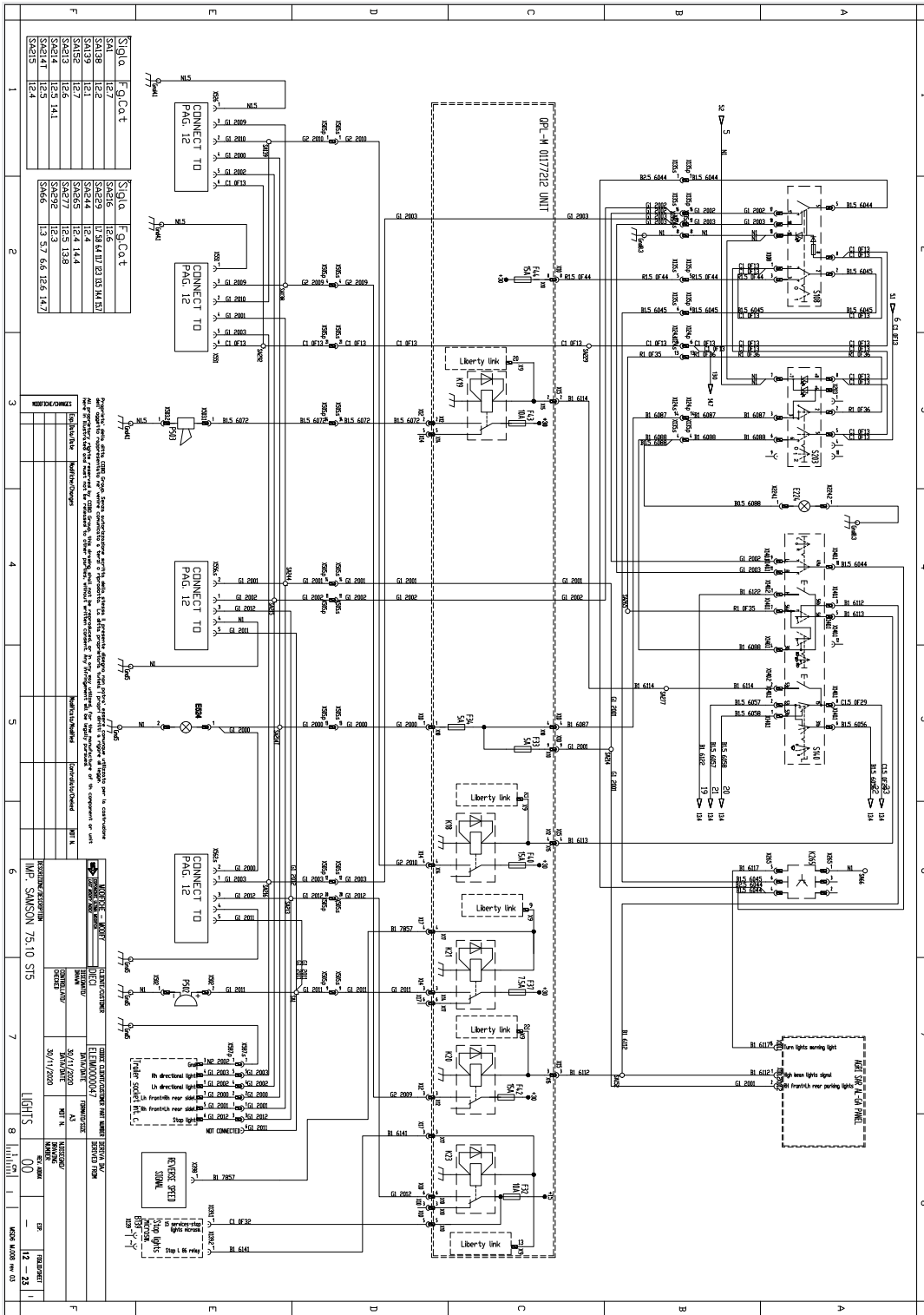

Figure: Wiring diagram 12

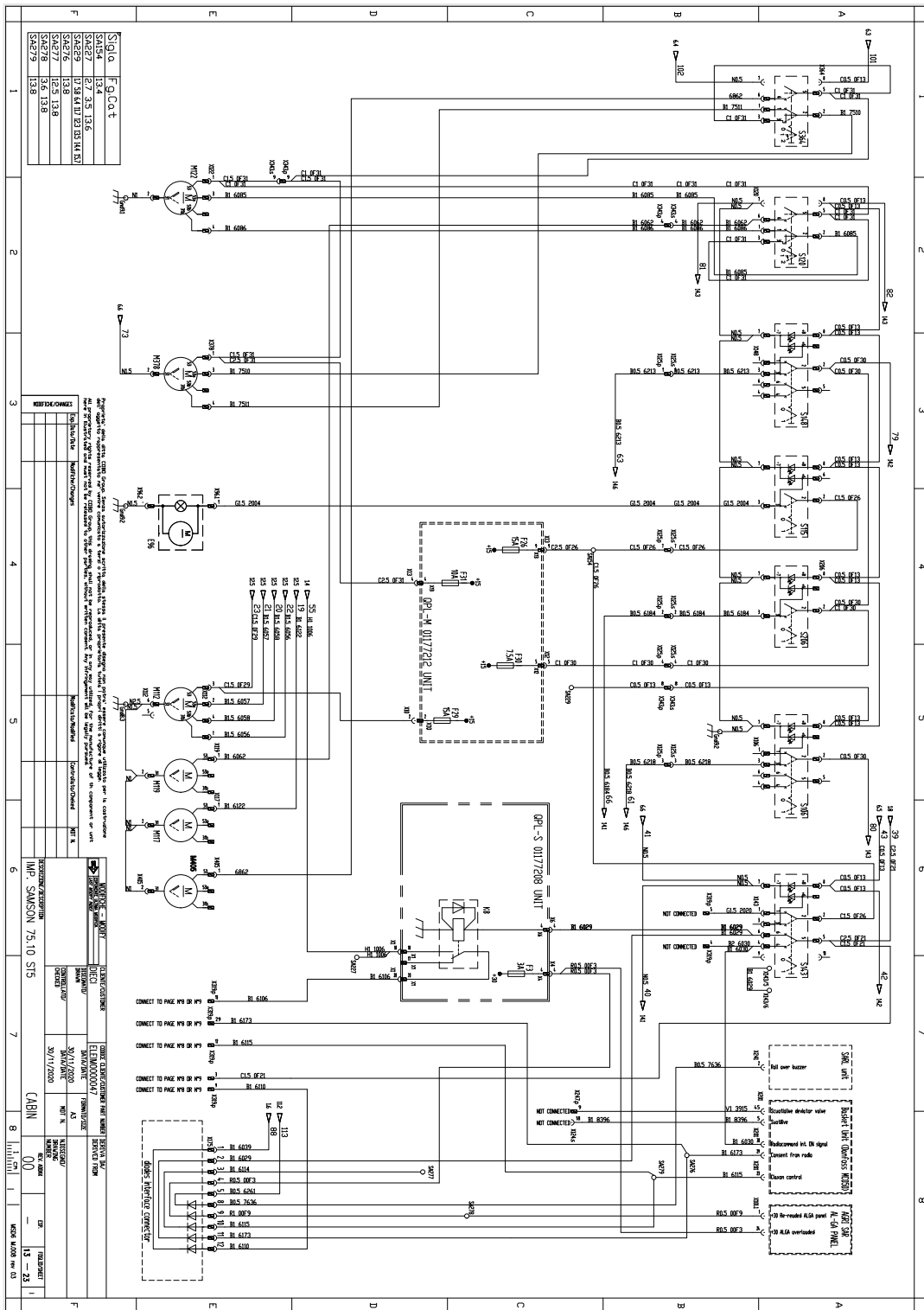

Figure: Wiring diagram 13

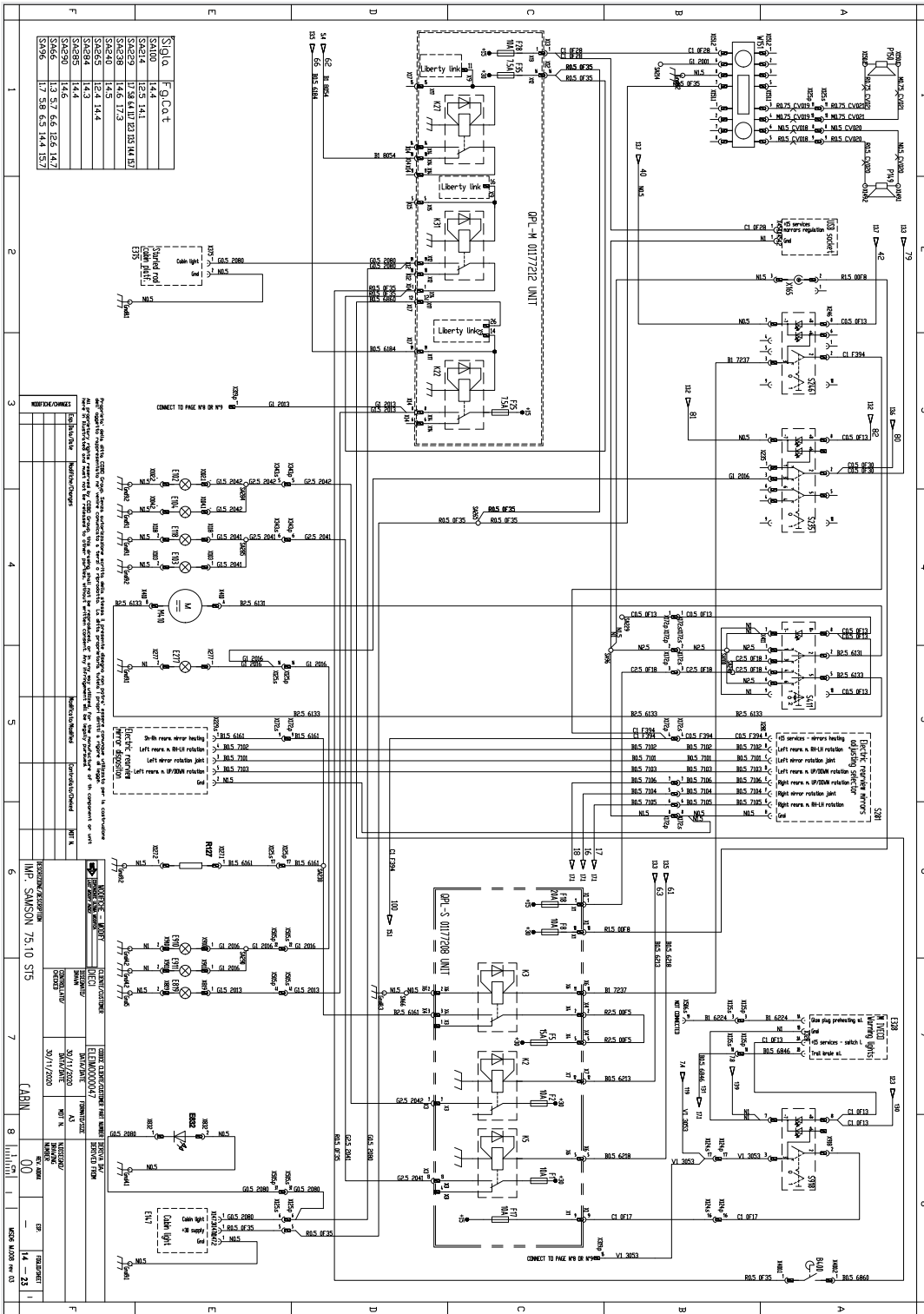

Figure: Wiring diagram 14

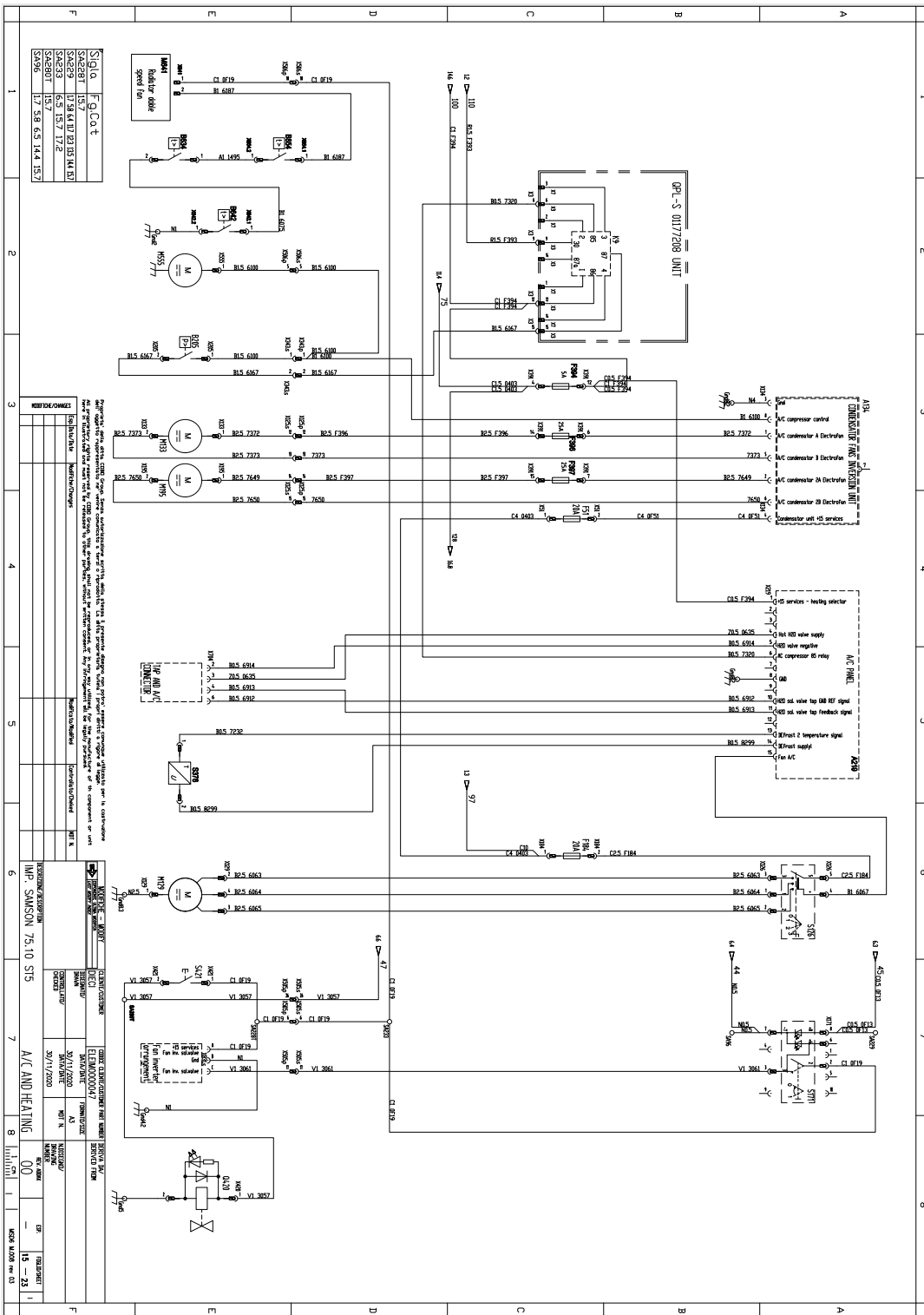

Figure: Wiring diagram 15

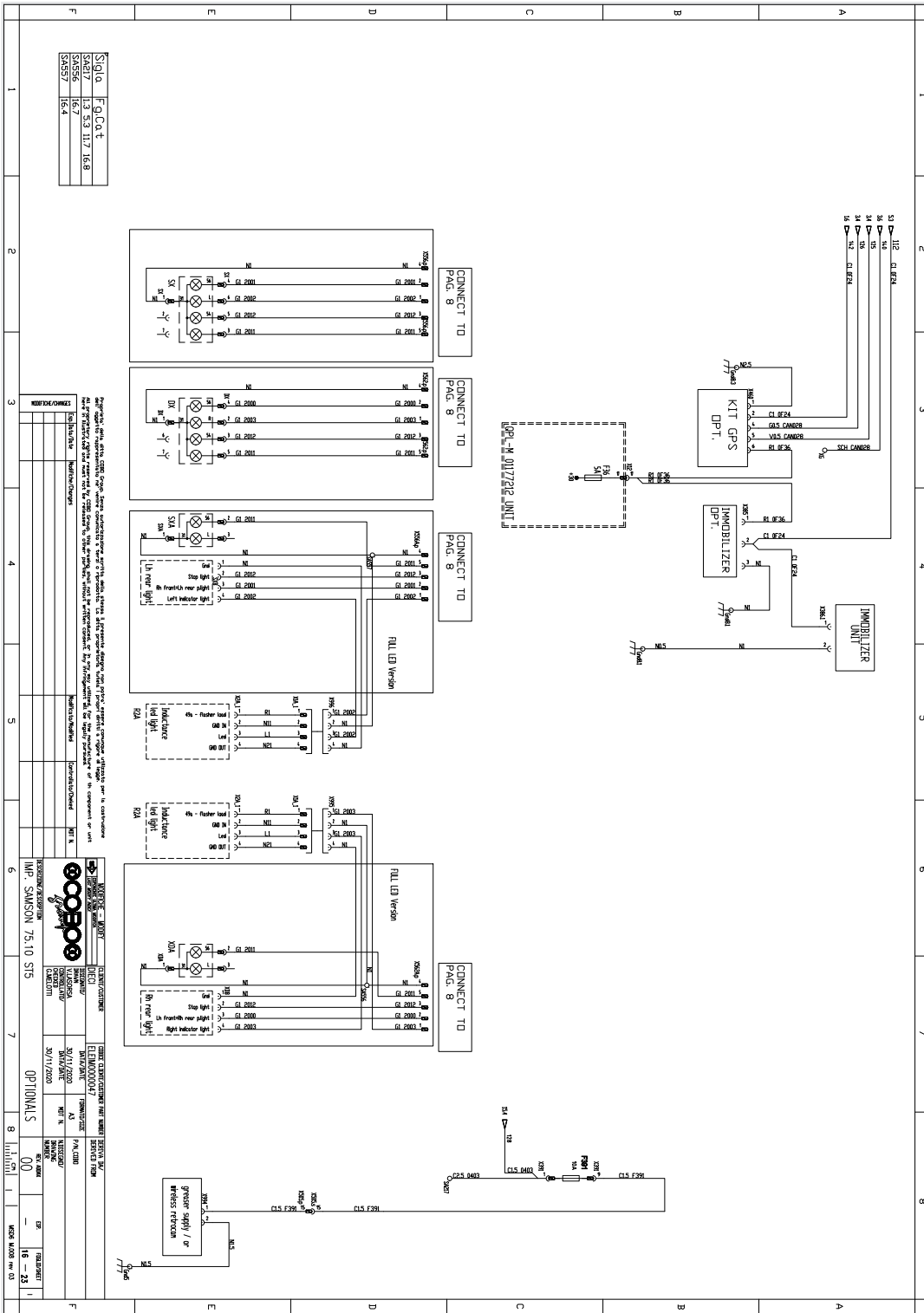

Figure: Wiring diagram 16

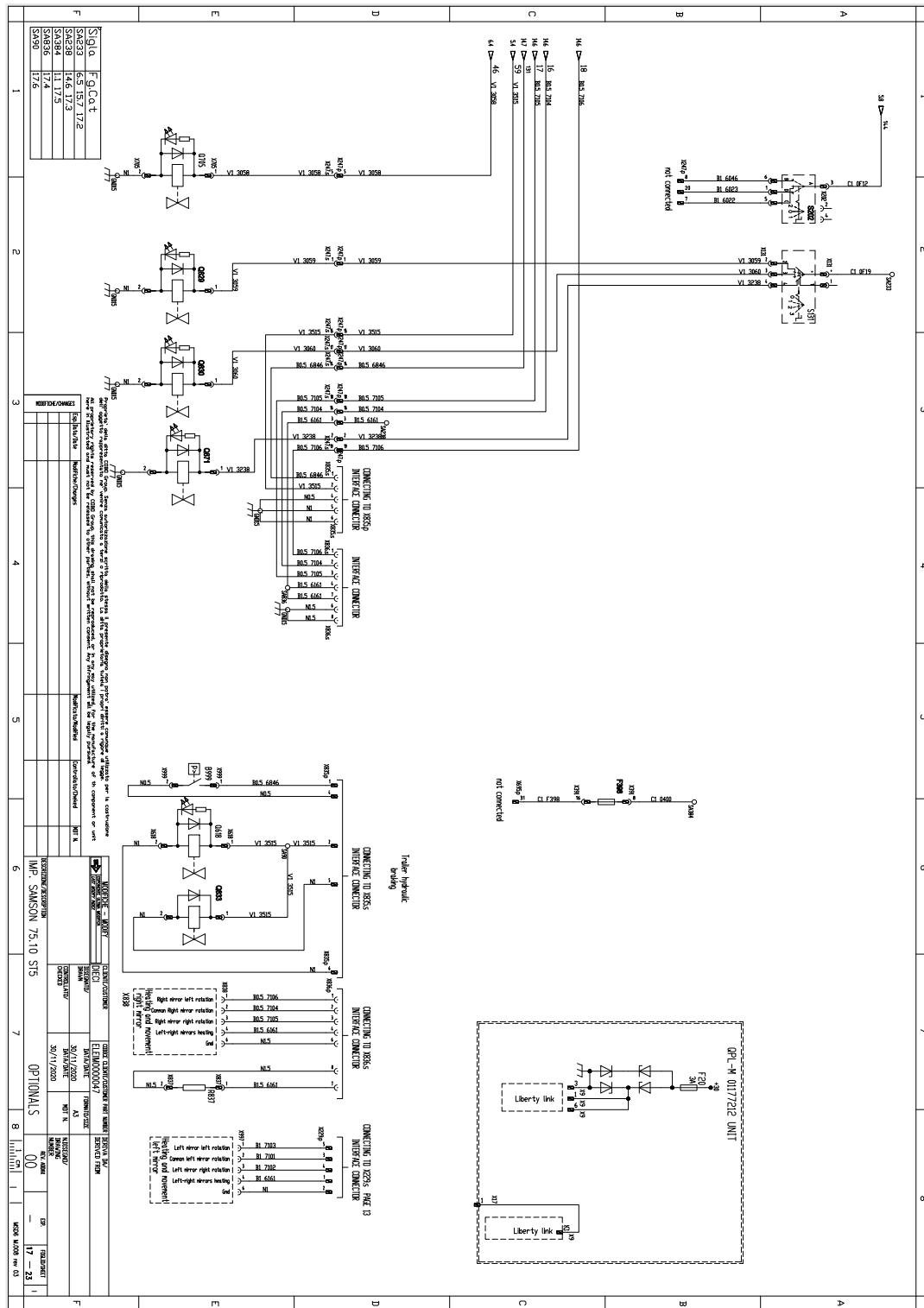

Figure: Wiring diagram 17

25.1 - Components legend

Position	Description
1	Diesel engine
2	Hydrostatic pump
3	Hydrostatic motor
4	Inching valve
5	Intake filter
6	Double gear pump
7	Intake filter
8	Return filter
9	Unloading valve
10	Priority valve
11	Levelling valve
12	Levelling cylinders
13	Fan hydraulic motor
14	Brake valve: parking and gearbox
15	Pressure switch
16	Pressure switch
17	3-way valve
18	Two-speed gearbox
19	Brake servo pump
20	Steering selecting valve
21	Power steering
22	Exhaust collector
23	Oil radiator
24	Distributor
25	Joystick servo control
26	Block valve
27	Lifting cylinder
28	Compensation cylinder
29	Tilting cylinder
30	Extension cylinder
31	Exhaust valve
32	Auxiliary sockets
33	Boom down control valve
34	Exhaust collector
35	Pressure switch
36	Servo brake accumulator
37	Cab pressure gauge
38	Exchange valve
39	Piston accumulators
40	Flow divider
41	Lifting device valve
42	Lifting device jacks

Position	Description
43	Diverter valve
44	Outriggers and levelling valve
45	Outriggers cylinders
46	Fan reversal valve

Agricultural/Industrial version optional	
(1)	Rear or boom head auxiliary sockets
(1a)	Trailer descent (for closed-centre distributor only)
(2)	Boom suspension
(3)	Three-point elevator
(4)	Fan reversal
(5)	Outriggers

25.2 - Hydraulic diagrams

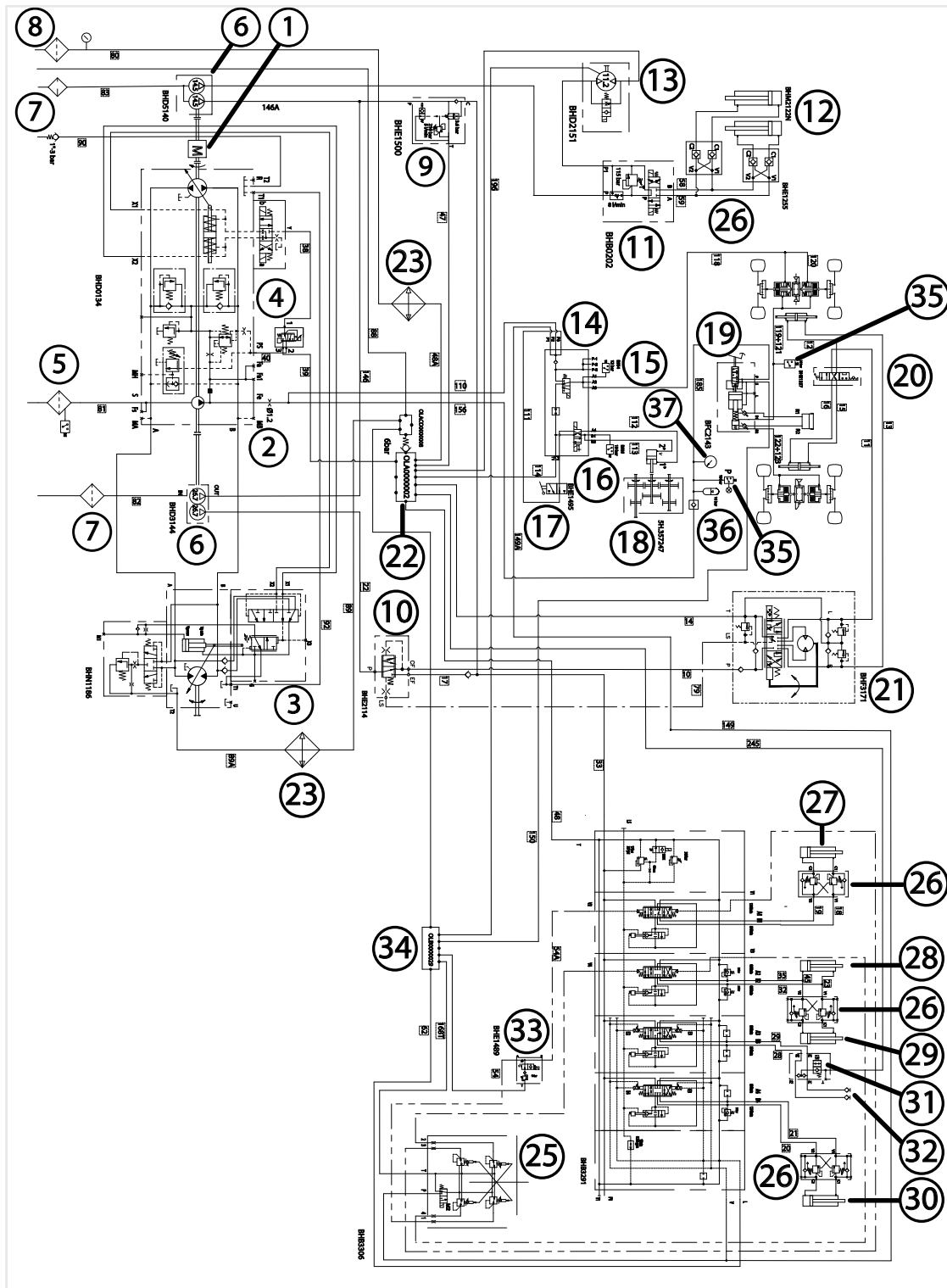

Figure: Hydraulic diagram

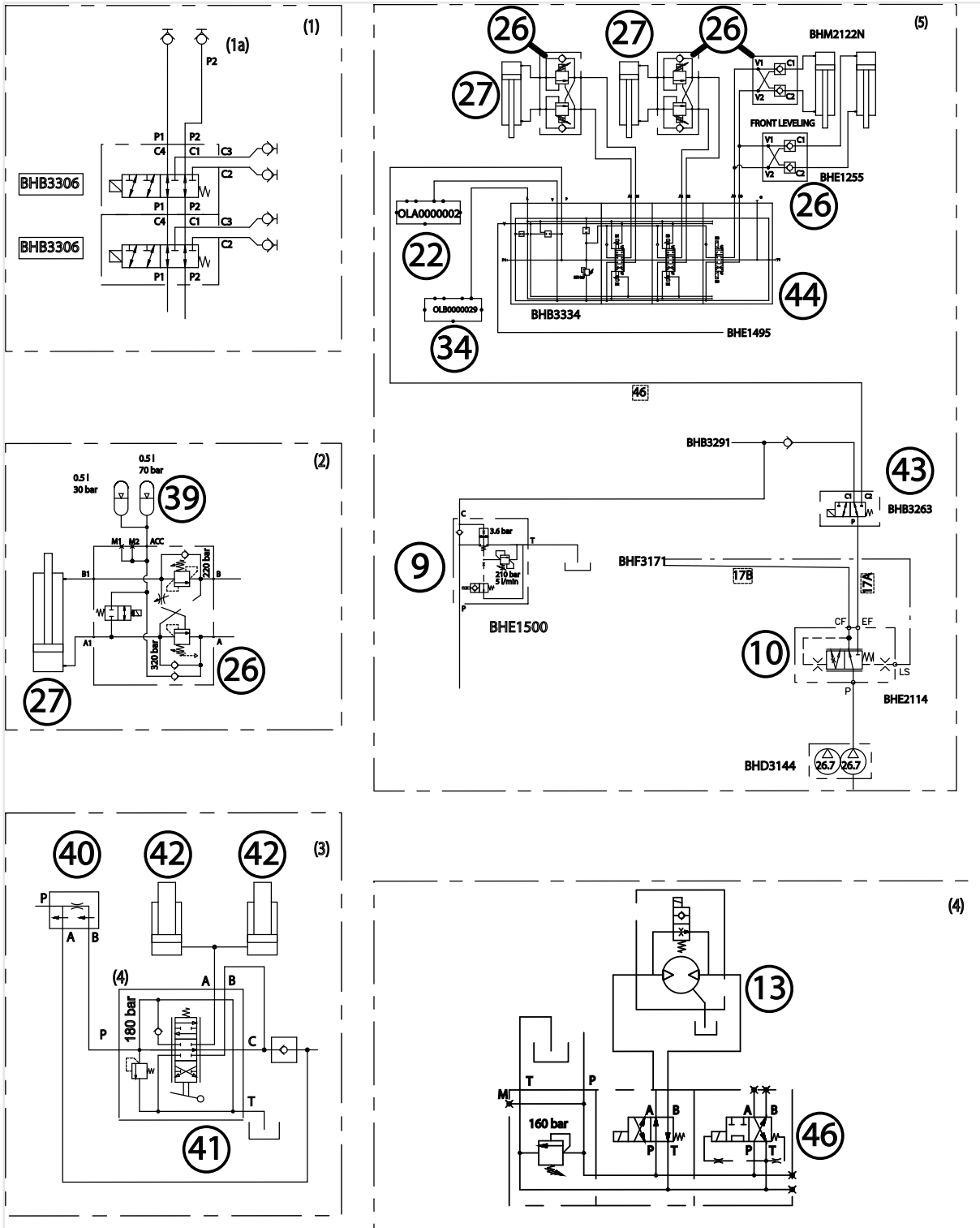
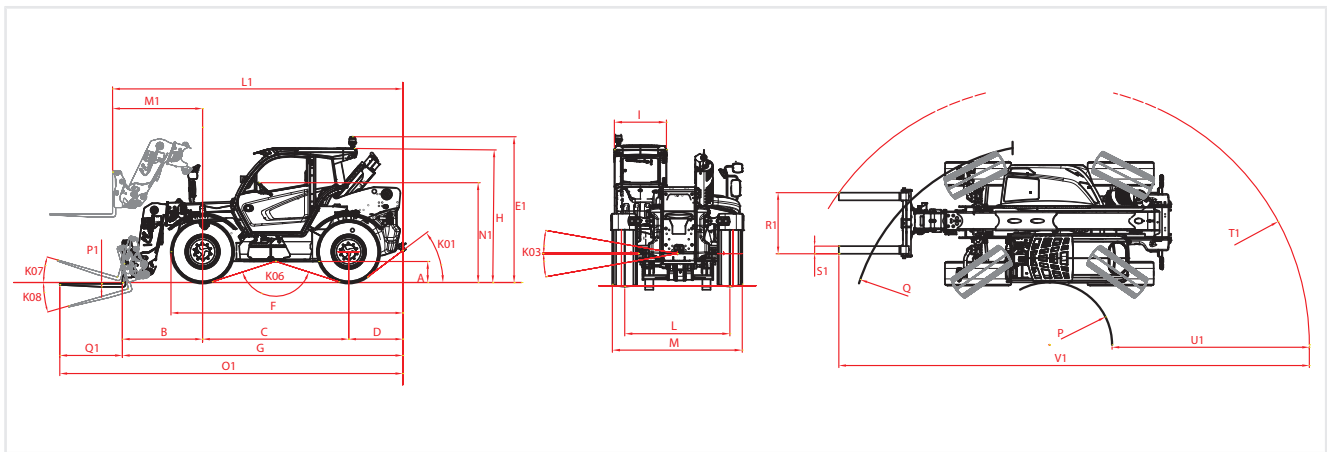

Figure: Agricultural/Industrial version optional hydraulic diagram

26.1 - Dimensions



	MFO3518	MFO3517
Vehicle model	SAMSON 75.10 - GD	AGRI MAX 75.10 - GD
A	390 mm (15,4 in)	390 mm (15,4 in)
B	1660 mm (65,4 in)	1660 mm (65,4 in)
C	2950 mm (116,1 in)	2950 mm (116,1 in)
D	1445 mm (56,9 in)	1445 mm (56,9 in)
F	4990 mm (196,5 in)	4990 mm (196,5 in)
G	5910 mm (232,7 in)	5910 mm (232,7 in)
H	2640 mm (103,9 in)	2640 mm (103,9 in)
I	960 mm (37,8 in)	960 mm (37,8 in)
L	1930 mm (76 in)	1930 mm (76 in)
P	1325 mm (52,2 in)	1325 mm (52,2 in)
Q	4035 mm (158,9 in)	4035 mm (158,9 in)
O1	7260 mm (285,8 in)	7260 mm (285,8 in)
M1	1880 mm (74 in)	1880 mm (74 in)
M	2390 mm (94,1 in)	2390 mm (94,1 in)
T1	5330 mm (209,8 in)	5330 mm (209,8 in)
U1	4000 mm (157,5 in)	4000 mm (157,5 in)

26.2 - Performance

	MFO3518	MFO3517
Vehicle model	SAMSON 75.10 - GD	AGRI MAX 75.10 - GD
Fork swiveling angle	134°	134°
Pull-out force	10600 daN (23830 lbf)	10600 daN (23830 lbf)
Towing force	8360 daN (18794 lbf)	8360 daN (18794 lbf)
Maximum climb angle	40%	40%
Outriggers maximum capacity	7500 kg (16535 lb)	7500 kg (16535 lb)
Wheels maximum capacity	7200 kg (15873 lb)	7200 kg (15873 lb)
Maximum capacity	7500 kg (16535 lb)	7500 kg (16535 lb)
Capacity at maximum height on wheels	3800 kg (8378 lb)	3800 kg (8378 lb)

	MFO3518	MFO3517
Capacity at maximum horizontal extension on wheels	2000 kg (4409 lb)	2000 kg (4409 lb)
Maximum horizontal extension on outriggers	5,40 m (17,7 ft)	5,40 m (17,7 ft)
Maximum horizontal extension on wheels	5,40 m (17,7 ft)	5,40 m (17,7 ft)
Maximum lifting height on outriggers	9,65 m (31,7 ft)	9,65 m (31,7 ft)
Maximum lifting height on wheels	9,50 m (31,2 ft)	9,50 m (31,2 ft)
Forward swiveling	7,5 s	7,5 s
Reverse swiveling	3,3 s	3,3 s
Descent	9,9 s	9,9 s
Retraction	5,1 s	5,1 s
Extension	11,4 s	11,4 s
Lifting	15,1 s	15,1 s
Boom type	Telescopic with 1 telescopic section and boom speed additional device	Telescopic with 1 telescopic section and boom speed additional device
Max speed (referred to wheels with maximum permitted diameter)	40 km/h (24,9 mph)	40 km/h (24,9 mph)

26.3 - Engine

	MFO3518	MFO3517
Vehicle model	SAMSON 75.10 - GD	AGRI MAX 75.10 - GD
Brand	FPT	FPT
Model	F4HGE4133	F4HGE4133
Fueling	Diesel	Diesel
Displacement	4485 cm ³ (274 in ³)	4485 cm ³ (274 in ³)
Operation	4-stroke	4-stroke
Cooling system	Liquid	Liquid
Nominal power	103 kW (138 HP)	103 kW (138 HP)
@rpm	2200 rpm	2200 rpm
Peak power	114 kW (153 HP)	114 kW (153 HP)
@rpm	1800 rpm	1800 rpm
Number and arrangement of cylinders	4, Vertical in line	4, Vertical in line
Injection	4-stroke Common Rail electronic injection	4-stroke Common Rail electronic injection
Consumption	280 g/kWh (460,6 lb/Hp h)	280 g/kWh (460,6 lb/Hp h)
@rpm	1900 rpm	1900 rpm
Maximum torque	640 Nm (472 lbft)	640 Nm (472 lbft)
@rpm	1500 rpm	1500 rpm
Intake	16-valve turbocharger with aftercooler	16-valve turbocharger with aftercooler
Emission standard	Stage V	Stage V
Exhaust gas treatment	(DOC + SCRoF)	(DOC + SCRoF)
Air Filter	Air pre-heating and air pre-filtering with dust separator	Air pre-heating and air pre-filtering with dust separator

26.4 - Weights

	MFO3518	MFO3517
Vehicle model	SAMSON 75.10 - GD	AGRI MAX 75.10 - GD
Unladen weight	12800 kg (28219 lb)	12800 kg (28219 lb)
Load per wheel	9250 kg (20393 lb)	9250 kg (20393 lb)

26.5 - Electrical and hydraulic system

	MFO3518	MFO3517
Vehicle model	SAMSON 75.10 - GD	AGRI MAX 75.10 - GD
Battery	12 V - 184Ah - 1200 A	12 V - 184Ah - 1200 A
Hydraulic pump type	Piston pump with variable flow rate for power steering and movements. Gear pump for Fan Drive.	Piston pump with variable flow rate for power steering and movements. Gear pump for Fan Drive.
Hydraulic pump capacity	160 L/min (42,3 gal/min)	160 L/min (42,3 gal/min)
Max. operating pressure	26,0 MPa (3771 psi)	26,0 MPa (3771 psi)
Distributor control	Proportional 4in1 Joystick	Proportional 4in1 Joystick
Boom hydraulic sockets	With Flat Face quick couplings with continuous oil function	With Flat Face quick couplings with continuous oil function
Maximum pressure at rear hydraulic sockets	26,0 MPa (3771 psi)	26,0 MPa (3771 psi)

26.6 - Transmission

	MFO3518	MFO3517
Vehicle model	SAMSON 75.10 - GD	AGRI MAX 75.10 - GD
Transmission type	Hydrostatic with variable displacement pump	Hydrostatic with variable displacement pump
Reversal	Electro-Hydraulic	Electro-Hydraulic
Transmission gearbox	Servo-controlled 2-speed	Servo-controlled 2-speed
Inching	With electronic pedal for controlled forward movement	With electronic pedal for controlled forward movement
Hydraulic motor	Hydrostatic with continuous automatic adjustment	Hydrostatic with continuous automatic adjustment

26.7 - Axles

	MFO3518	MFO3517
Vehicle model	SAMSON 75.10 - GD	AGRI MAX 75.10 - GD
Type of axles	2 steering, with 4 epicycloidal reduction gears	2 steering, with 4 epicycloidal reduction gears
Service braking	Oil bath with servo brake on front and rear axle with double hydraulic system	Oil bath with servo brake on front and rear axle with double hydraulic system
Parking braking	Negative actuation with electrical control	Negative actuation with electrical control
Front axle	With transverse levelling device +/- 7°	With transverse levelling device +/- 7°
Rear axle	Swinging	Swinging

	MFO3518	MFO3517
Type of steering	4 wheels / transversal / 2 wheels	4 wheels / transversal / 2 wheels

26.8 - Acoustic pressure

	MFO3518	MFO3517
Vehicle model	SAMSON 75.10 - GD	AGRI MAX 75.10 - GD
Acoustic pressure: Value perceived by the operator with closed cab	72,0±4 dB(A)	72,0±4 dB(A)

26.9 - Acoustic power

	MFO3518	MFO3517
Vehicle model	SAMSON 75.10 - GD	AGRI MAX 75.10 - GD
Acoustic power: Reference standard	Directive 2000/14/EC	Directive 2000/14/EC
Acoustic power: Guaranteed value	107 dB(A)	107 dB(A)
Acoustic power: Measured value	106 dB(A)	106 dB(A)

26.10 - Vibration

	MFO3518	MFO3517
Vehicle model	SAMSON 75.10 - GD	AGRI MAX 75.10 - GD
Reference standard for seat vibrations	EN 1032	EN 1032
Value for seat vibrations	1,39 m/s ² (4,6 ft/s ²)	1,39 m/s ² (4,6 ft/s ²)
Uncertainty for seat vibrations value	0,42 m/s ² (1,4 ft/s ²)	0,42 m/s ² (1,4 ft/s ²)
Reference standard for steering wheel vibrations	EN 1032	EN 1032
Value for steering wheel vibrations	2,64 m/s ² (8,7 ft/s ²)	2,64 m/s ² (8,7 ft/s ²)
Uncertainty for steering wheel vibrations value	0,79 m/s ² (2,6 ft/s ²)	0,79 m/s ² (2,6 ft/s ²)

26.11 - Filling

	MFO3518	MFO3517
Vehicle model	SAMSON 75.10 - GD	AGRI MAX 75.10 - GD
Type of steering	4 wheels / transversal / 2 wheels	4 wheels / transversal / 2 wheels
Engine oil quantity	8,7 L (2,3 gal)	8,7 L (2,3 gal)
Engine oil specifications	SAE 10W-30/SAE15W-40(<25°C) SAE 10W-30/SAE15W-40 (<-10° A <25°)	SAE 10W-30/SAE15W-40(<25°C) SAE 10W-30/SAE15W-40 (<-10° A <25°)
Front axle oil quantity	7,75 L (2,05 gal)	7,75 L (2,05 gal)
Front reduction gears oil quantity	1,90 L (0,5 gal)	1,90 L (0,5 gal)
Front axle oil specifications	DIECI GEAR EP/E LS 85W-90 API GL-5, MIL-L-2105D; (< -20°C / < -4°F) DIECI SPECIAL LS SYNT AXEL OIL 75W-90	DIECI GEAR EP/E LS 85W-90 API GL-5, MIL-L-2105D; (< -20°C / < -4°F) DIECI SPECIAL LS SYNT AXEL OIL 75W-90
Rear axle oil quantity	7,50 L (1,98 gal)	7,50 L (1,98 gal)
Rear reduction gears oil quantity	1,00 L (0,26 gal)	1,00 L (0,26 gal)
Rear axle oil specifications	DIECI GEAR EP/E LS 85W-90 API GL-5, MIL-L-2105D; (< -20°C / < -4°F) DIECI SPECIAL LS SYNT AXEL OIL 75W-90	DIECI GEAR EP/E LS 85W-90 API GL-5, MIL-L-2105D; (< -20°C / < -4°F) DIECI SPECIAL LS SYNT AXEL OIL 75W-90
Transmission gearbox oil quantity	3,70 L (0,98 gal)	3,70 L (0,98 gal)
Transmission gearbox oil specifications	(From -10°C/14°F to +35°C/95°F) DIECI GEAR OIL EP/E SAE 80W-90 API GL-5, MIL-L-2105D, MAN 342 Type M-1; (from -30°C/-22°F to +10°C/14°F) DIECI MTF III FLUID	(From -10°C/14°F to +35°C/95°F) DIECI GEAR OIL EP/E SAE 80W-90 API GL-5, MIL-L-2105D, MAN 342 Type M-1; (from -30°C/-22°F to +10°C/14°F) DIECI MTF III FLUID
Braking circuit oil quantity	1,20 L (0,32 gal)	1,20 L (0,32 gal)
Braking circuit oil specifications	DIECI MTF III FLUID	DIECI MTF III FLUID
Coolant quantity	12,00 L (3,17 gal)	12,00 L (3,17 gal)
Coolant specifications	DIECI OAT ORANGE COOLANT READY	DIECI OAT ORANGE COOLANT READY
Grease specifications	DIECI BLUE GREASE EP	DIECI BLUE GREASE EP
Hydraulic oil type	DIECI Hydro Telehandler Fluid ISO46	DIECI Hydro Telehandler Fluid ISO46
Hydraulic system (total)	210,0 L (55,48 gal)	210,0 L (55,48 gal)
Air conditioning refrigerant quantity	1,30 kg (3 lb)	1,30 kg (3 lb)
Air conditioning refrigerant specifications	R134A	R134A
AdBlue tank	27,0 L (7,13 gal)	27,0 L (7,13 gal)
Fuel tank	125,0 L (33,02 gal)	125,0 L (33,02 gal)

26.11.1 - DIECI Hydro Telehandler Fluid ISO46

The sticker shown aside (170350-1) indicates that the hydraulic circuit is filled with hydraulic oil DIECI Hydro Telehandler Fluid ISO46.



170350-1

Specifications:

ISO 6743-4 HV, Afnor NFE 48-602, ISO 11158, DIN 51524 Part 3 HVLP, Afnor NFE 48-603 HV, ASTM D6158, Denison HF-0 / HF-1 / HF-2, Eaton Vickers I-286-S / M-2950-S, Cincinnati Vehicle P-68 / P-69 / P-70, Afnor NFE 48-690(dry), Afnor NFE 48-691(wet), U.S. Steel 126 / 127 / 136, JCMAS HK, Bosch variable vane pumps, Rexroth RE 90220, Sauer Danfoss 520L0463, General Motors (LS-2) LH-03-1 / LH-04-1 / LH-06-1, SEB 181222.

Chemical-physical characteristics

Properties	Analysis method	Unit of measure	Value
Density at 15°C	ASTM D1298	kg/l	0.88
Viscosity at 40°C	ASTM D445	cSt	46.6
Viscosity at 100°C	ASTM D445	cSt	8.6
Viscosity Index	ASTM D2270	-	165
Kinematic viscosity at 40°C after Sonic Shear	ASTM D445	cSt	41.6
Viscosity Index after Sonic Shear	ASTM D2270	-	144
FZG Failure Load Stage	ASTM D5182	Stage	12
Flash Point (C.O.C.)	ASTM D92	°C	210
Pour point	ASTM D97	°C	-35
Temperature for Brookfield viscosity of 750cP	ASTM D2983	°C	-9

26.11.2 - DIECI Hydro Telehandler Fluid ISO32



NOTE

Hydraulic oil for cold climates is an optional.

Consult your dealer in case of doubts or information on your vehicle.

The sticker shown aside (170351-1) indicates that the hydraulic circuit is filled with hydraulic oil DIECI Hydro Telehandler Fluid ISO32.



170351-1

Specifications:

ISO 6743-4 HV, Afnor NFE 48-602, ISO 11158, DIN 51524 Part 3 HVL P, Afnor NFE 48-603 HV, ASTM D6158, Denison HF-0 / HF-1 / HF-2, Eaton Vickers I-286-S / M-2950-S, Cincinnati Vehicle P-68 / P-69 / P-70, Afnor NFE 48-690(dry), Afnor NFE 48-691(wet), U.S. Steel 126 / 127 / 136, JCMAS HK, Bosch variable vane pumps, Rexroth RE 90220, Sauer Danfoss 520L0463, General Motors (LS-2) LH-03-1 / LH-04-1 / LH-06-1, SEB 181222

Chemical-physical characteristics:

Properties	Analysis method	Unit of measure	Value
Color	-	-	Green-Blue
Density at 15°C	ASTM D1298	kg/l	0.878
Viscosity at 40°C	ASTM D445	cSt	32.4
Viscosity at 100°C	ASTM D445	cSt	6.6
Viscosity Index	ASTM D2270	-	165
Flash Point (C.O.C.)	ASTM D92	°C	205
Pour point	ASTM D97	°C	-37

26.11.3 - Declaration of conformity for F-Gas

In accordance with Art. 12 of EU Reg.No. 517/2014 concerning the fluorinated gases contained in the air-conditioning system, on the vehicles there are:

- Label indicating the amount of fluorinated gases present (Fig. 170501).
- Declaration of Conformity (a facsimile is shown below)

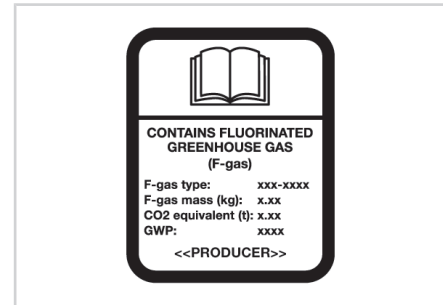

170501-1

(Declaration of conformity with article 14 of Regulation (EU) No. 517/2014 of the European Parliament and of the Council)

We Dieci s.r.l. (VAT number 01682740350), declare under our sole responsibility that when placing on the market pre-charged equipment, which we import to or manufacture in the Union, the hydrofluorocarbons contained in that equipment are accounted for within the quota system referred to in Chapter IV of Regulation (EU) No 517/2014 of the European Parliament and of the Council as:

[please tick the relevant option(s): coverage by the quota system is achieved by one or more of the options below]

A. we hold authorisation(s) issued in accordance with Article 18(2) of Regulation (EU) No 517/2014 and registered in the registry referred to in Article 17 of that Regulation, at the time of release for free circulation to use the quota of a producer or importer of hydrofluorocarbons subject to Article 15 of Regulation (EU) No 517/2014 that cover(s) the quantity of hydrofluorocarbons contained in the equipment.

B. *[for importers of equipment only]* the hydrofluorocarbons contained in the equipment have been placed on the market in the Union, subsequently exported and charged into the equipment outside the Union, and the undertaking that placed the hydrofluorocarbons on the market made a declaration stating that the quantity of hydrofluorocarbons has been or will be reported as placed on the market in the Union and that it has not been and will not be reported as direct supply for export in the meaning of Article 15(2)(c) of Regulation (EU) No 517/2014 pursuant to Article 19 of Regulation (EU) No 517/2014 and Section 5C of the Annex to Commission Implementing Regulation (EU) No 1191/2014.

C. *[for equipment manufactured in the Union only]* the hydrofluorocarbons charged into the equipment were placed on the market by a producer or importer of hydrofluorocarbons subject to Article 15 of Regulation (EU) No 517/2014.

Signed for and on behalf of: Ennio Manghi, Director at DIECI S.r.l.

Montecchio Emilia, 31.01.2017

DIECI SRL
Via E. Majorana, 2-4
Montecchio Emilia (RE)
 One of the Directors
 Ennio Manghi

Dieci Srl
 Via E. Majorana, 2-4 • 42027 Montecchio Emilia • (Reggio Emilia) ITALY
 Tel. ++39 0522 869611 - Fax ++39 0522 869798 (Reception) - Fax ++39 0522 869797 (Attn.me)
www.dieci.com • E-mail: info@dieci.com
Cap. Soc. Int. Vers. € 10.000.000,00 Reg. Impr. R.E. N. 01283560686 R.E.A. R.E. N. 204278 - C.F. 01283560686 • P.I. 01682740350

26.12 - SAMSON 75.10 - GD

26.12.1 - Equipment

	Production code	Description
TCV0042	BCV8339	Fork spreader c/w forks 150 x 60 L = 1200 mm
TCV0011	BCV8276	Fork counterplate (with pins) for use with quick attachment
TCV0043	BCV8341	Counterplate FEM 4A
TFR0040	BUD1250	Forks FEM 4A 150X60X1200
TFR0017	BUD1187	Floating forks mm 150 x 60 L = 1200. Capacity 7.5 t
TFR0018	BUD1188	Floating forks mm 200 x 60 L = 1400. Capacity 7.5 t
TFR0012	BUD1050/OG, BUD1182	Fork extensions L = 1900 mm (Valid exclusively for floating forks mm 150 x 60 L = 1200)
TFR0013	BUD1054/OG, BUD1186	Fork extensions L = 1900 mm (Valid exclusively for floating forks mm 200x60 L = 1400)
TFR0014	BUD1122/OG	Fork counterplate guard
TGN0090	BUD1252	Fork for logs
TGN0091	BUD1253	Multipurpose fork with holder
TBN0262	BUB2775	4 in 1 bucket, capacity m ³ 1.25 SAE heap (L = 2.45 m)
TBN0263	BUB2776	4 in 1 bucket with teeth, capacity m ³ 1.00 SAE heaped (L = 2.40 m)
TBN0264	BUB2775-S	4 in 1 bucket with bolted blade protector capacity m ³ 1.25 SAE heaped (L = 2.45 m)
TBN0185	BUB2654	Standard bucket, m ³ 1.25 SAE heaped, (width 2.45 m). (The bucket with blade protector is recommended) (Equipment approved for road circulation in Italy)
TBN0194	BUB2655	Standard bucket with teeth, m ³ 1.25 SAE heaped, (width 2.45 m) with teeth protection cover. (Equipment approved for road circulation in Italy)
TBN0190	BUB2654-S	Standard bucket with bolted blade protector, m ³ 1.25 SAE heaped, (width 2.45 m) with blade protector. (Equipment approved for road circulation in Italy)
TBN0198	BUB2656	Oversize bucket (material max spec. weight 0.8 t/ m ³) m ³ 2.50 SAE heaped (width 2.45 m) (The bucket with blade protector is recommended)
TBN0202	BUB2656-S	Oversize bucket with bolted blade protector (material spec. weight max 0.8 t/ m ³) m ³ 2.50 SAE heaped (width 2.45 m)
TBN0207	BUB2657	Extra-oversize bucket (material max spec. weight 0.4 t/ m ³) m ³ 3.5 SAE heaped (width 2.45 m) (The bucket with blade protector is recommended)
TBN0212	BUB2657-S	Extra-oversize bucket with bolted blade protector (material max spec. weight 0.4 t/ m ³) m ³ 3.5 SAE heaped (width 2.45 m)
TBN0321	BUB2806	Bucket for Cereals with bolted blade protector (material spec. weight max 0.4 t/m ³), 4.0 m ³ SAE heap (width 2.45 m)
TBN0265	BUB2777	Bucket with grab for manure capacity m ³ 2.50 SAE heaped (width 2.45 m)
TBN0266	BUB2777-S	Bucket with grab for manure and bolted blade guard, capacity m ³ 2.50 SAE heaped (width 2.45 m)

	Production code	Description
TBN0267	BUB2778	Bucket with grab for ensiled material m ³ 2.50 SAE heaped (width 2.45 m)
TBN0268	BUB2778-S	Bucket with grab for silage and bolted blade guard capacity m ³ 2.50 SAE heaped (width 2.45 m)
TBN0249	CARSA0000940	Blade protector width 2.45 m to be bolted
TBN0234	ASMCM0000325-OG	Blade protector/Teeth cover Width 2.45 m
TBN0256	BUB2658	No. 8 teeth for standard bucket
TBN0251	ASMCM0000257-OG	Protection guard for bucket
TBN0142	ASMCM0000258, ASMCM0000259	Protection guard for bucket with grab
TBN0132	DRE3511	Mobile level indicator
TGN0087	AAAAAAA	Snow plough L=3.0 m. (For end outline marker lamps request additional information)
TCS0165	BUD6570	Front passenger basket cm 120 x 215. Capacity 300 Kg including 3 persons (Proportional hydraulic distributor with pre-arrangement for basket and lifting equipment is compulsory)
TCS0166	BUD6571	Front passenger basket cm 120 x 240 with hydraulic extension up to cm 420. Capacity 300 Kg including 3 persons (Proportional hydraulic distributor with pre-arrangement for basket and lifting equipment is compulsory)
TCS0167	BUD6572	Trilateral passenger basket cm 120 x 215. Capacity 300 Kg including 3 persons (Proportional hydraulic distributor with pre-arrangement for basket and lifting equipment is compulsory)
TCS0168	BUD6573	Trilateral passenger basket cm 120 x 240 with hydraulic extension up to cm 420. Capacity 300 Kg including 3 persons (Proportional hydraulic distributor with pre-arrangement for basket and lifting equipment is compulsory)
TCS0169	BUD6574	Trilateral passenger basket cm 120 x 215. Capacity 800 Kg including 3 persons (Proportional hydraulic distributor with pre-arrangement for basket and lifting equipment is compulsory)
TCS0170	BUD6575	Trilateral passenger basket cm 120 x 240 with hydraulic extension up to cm 420. Capacity 800 Kg including 3 persons (Proportional hydraulic distributor with pre-arrangement for basket and lifting equipment is compulsory)
TCS0016	BUD6217	Material basket 200 x 120 x 130 cm with side door. Capacity 1000 kg
TSL0081	BUD4574	Jib (crane extension) L = 1.3 m with hook (capacity 2.0 t) (Equipment recognition system is compulsory)
TSL0082	BUD4575	Jib (crane extension) L = 2.5 m with hook (capacity 1.2 t) (Equipment recognition system is compulsory)
TSL0083	BUD4576	Jib L = 1.00 m with hook (capacity 3.0 t) (Equipment recognition system is compulsory)
TSL0084	BUD4577	Jib L = 1.40 m with hook (capacity 3.0 t) (Equipment recognition system is compulsory)
TSL0045	BUB2631	Hook for fork carriage with the same capacity as the vehicle valid for plate with double-quick coupling
TSL0085	BUD4578	Jib (crane extension) L = 1.3 m with winch (Capacity 2.0 t) (Equipment recognition system is compulsory) (Incompatible with closed centre services distributor, where present)

	Production code	Description
TSL0086	BUD4579	Jib (crane extension) L = 2.5 m with winch (Capacity 1.2 t) (Equipment recognition system is compulsory) (Incompatible with closed centre services distributor, where present)
TSL0089	BUD4582	Winch for fork carriage (5.0 t capacity) with rope guide, double pull. (Equipment recognition system is compulsory) (Incompatible with closed centre services distributor, where present)

26.13 - AGRI MAX 75.10 - GD

26.13.1 - Equipment

	Production code	Description
TCV0042	BCV8339	Fork spreader c/w forks 150 x 60 L = 1200 mm
TCV0011	BCV8276	Fork counterplate (with pins) for use with quick attachment
TCV0043	BCV8341	Counterplate FEM 4A
TFR0040	BUD1250	Forks FEM 4A 150X60X1200
TFR0017	BUD1187	Floating forks mm 150 x 60 L = 1200. Capacity 7.5 t
TFR0018	BUD1188	Floating forks mm 200 x 60 L = 1400. Capacity 7.5 t
TFR0012	BUD1050/0G, BUD1182	Fork extensions L = 1900 mm (Valid exclusively for floating forks mm 150 x 60 L = 1200)
TFR0013	BUD1054/0G, BUD1186	Fork extensions L = 1900 mm (Valid exclusively for floating forks mm 200x60 L = 1400)
TFR0014	BUD1122/0G	Fork counterplate guard
TGN0090	BUD1252	Fork for logs
TGN0091	BUD1253	Multipurpose fork with holder
TBN0262	BUB2775	4 in 1 bucket, capacity m ³ 1.25 SAE heap (L = 2.45 m)
TBN0263	BUB2776	4 in 1 bucket with teeth, capacity m ³ 1.00 SAE heaped (L = 2.40 m)
TBN0264	BUB2775-S	4 in 1 bucket with bolted blade protector capacity m ³ 1.25 SAE heaped (L = 2.45 m)
TBN0185	BUB2654	Standard bucket, m ³ 1.25 SAE heaped, (width 2.45 m). (The bucket with blade protector is recommended) (Equipment approved for road circulation in Italy)
TBN0194	BUB2655	Standard bucket with teeth, m ³ 1.25 SAE heaped, (width 2.45 m) with teeth protection cover. (Equipment approved for road circulation in Italy)
TBN0190	BUB2654-S	Standard bucket with bolted blade protector, m ³ 1.25 SAE heaped, (width 2.45 m) with blade protector. (Equipment approved for road circulation in Italy)
TBN0198	BUB2656	Oversize bucket (material max spec. weight 0.8 t/ m ³) m ³ 2.50 SAE heaped (width 2.45 m) (The bucket with blade protector is recommended)
TBN0202	BUB2656-S	Oversize bucket with bolted blade protector (material spec. weight max 0.8 t/ m ³) m ³ 2.50 SAE heaped (width 2.45 m)
TBN0207	BUB2657	Extra-oversize bucket (material max spec. weight 0.4 t/ m ³) m ³ 3.5 SAE heaped (width 2.45 m) (The bucket with blade protector is recommended)
TBN0212	BUB2657-S	Extra-oversize bucket with bolted blade protector (material max spec. weight 0.4 t/ m ³) m ³ 3.5 SAE heaped (width 2.45 m)
TBN0321	BUB2806	Bucket for Cereals with bolted blade protector (material spec. weight max 0.4 t/m ³), 4.0 m ³ SAE heap (width 2.45 m)
TBN0265	BUB2777	Bucket with grab for manure capacity m ³ 2.50 SAE heaped (width 2.45 m)
TBN0266	BUB2777-S	Bucket with grab for manure and bolted blade guard, capacity m ³ 2.50 SAE heaped (width 2.45 m)

	Production code	Description
TBN0267	BUB2778	Bucket with grab for ensiled material m ³ 2.50 SAE heaped (width 2.45 m)
TBN0268	BUB2778-S	Bucket with grab for silage and bolted blade guard capacity m ³ 2.50 SAE heaped (width 2.45 m)
TBN0249	CARSA0000940	Blade protector width 2.45 m to be bolted
TBN0234	ASMCM0000325-0G	Blade protector/Teeth cover Width 2.45 m
TBN0256	BUB2658	No. 8 teeth for standard bucket
TBN0251	ASMCM0000257-0G	Protection guard for bucket
TBN0142	ASMCM0000258, ASMCM0000259	Protection guard for bucket with grab
TBN0132	DRE3511	Mobile level indicator
TGN0087	AAAAAAA	Snow plough L=3.0 m. (For end outline marker lamps request additional information)
TCS0165	BUD6570	Front passenger basket cm 120 x 215. Capacity 300 Kg including 3 persons (Proportional hydraulic distributor with pre-arrangement for basket and lifting equipment is compulsory)
TCS0166	BUD6571	Front passenger basket cm 120 x 240 with hydraulic extension up to cm 420. Capacity 300 Kg including 3 persons (Proportional hydraulic distributor with pre-arrangement for basket and lifting equipment is compulsory)
TCS0167	BUD6572	Trilateral passenger basket cm 120 x 215. Capacity 300 Kg including 3 persons (Proportional hydraulic distributor with pre-arrangement for basket and lifting equipment is compulsory)
TCS0168	BUD6573	Trilateral passenger basket cm 120 x 240 with hydraulic extension up to cm 420. Capacity 300 Kg including 3 persons (Proportional hydraulic distributor with pre-arrangement for basket and lifting equipment is compulsory)
TCS0169	BUD6574	Trilateral passenger basket cm 120 x 215. Capacity 800 Kg including 3 persons (Proportional hydraulic distributor with pre-arrangement for basket and lifting equipment is compulsory)
TCS0170	BUD6575	Trilateral passenger basket cm 120 x 240 with hydraulic extension up to cm 420. Capacity 800 Kg including 3 persons (Proportional hydraulic distributor with pre-arrangement for basket and lifting equipment is compulsory)
TCS0016	BUD6217	Material basket 200 x 120 x 130 cm with side door. Capacity 1000 kg
TSL0081	BUD4574	Jib (crane extension) L = 1.3 m with hook (capacity 2.0 t) (Equipment recognition system is compulsory)
TSL0082	BUD4575	Jib (crane extension) L = 2.5 m with hook (capacity 1.2 t) (Equipment recognition system is compulsory)
TSL0083	BUD4576	Jib L = 1.00 m with hook (capacity 3.0 t) (Equipment recognition system is compulsory)
TSL0084	BUD4577	Jib L = 1.40 m with hook (capacity 3.0 t) (Equipment recognition system is compulsory)
TSL0045	BUB2631	Hook for fork carriage with the same capacity as the vehicle valid for plate with double-quick coupling
TSL0085	BUD4578	Jib (crane extension) L = 1.3 m with winch (Capacity 2.0 t) (Equipment recognition system is compulsory) (Incompatible with closed centre services distributor, where present)

	Production code	Description
TSL0086	BUD4579	Jib (crane extension) L = 2.5 m with winch (Capacity 1.2 t) (Equipment recognition system is compulsory) (Incompatible with closed centre services distributor, where present)
TSL0089	BUD4582	Winch for fork carriage (5.0 t capacity) with rope guide, double pull. (Equipment recognition system is compulsory) (Incompatible with closed centre services distributor, where present)

26.14 - Environmental conditions

Although the vehicle and the equipment can be used in several different situations, however, it is necessary to observe, as a precautionary measure, compliance with minimum standards of operation as specified below:

Parameter	Allowed values
Operating temperatures	from -20°C to +40 °C (from -4 °F to 104 °F)
Average daily temperature	< +40 °C (< 104 °F)
Storage temperature	from -25 °C to +50 °C (from -13 °F to 122 °F)
Humidity	from 20 % to 95 %
Altitude	< 2500 m (< 8200 ft)

Table 9: Environmental conditions table

26.15 - Electromagnetic Interference

In the case of additional equipment installed by the customer, the user must verify if the installation causes interference of any kind with the tools of the vehicle; if so, the user must correct such interferences.

It is essential to pay particular attention to mobile devices such as radio communications (telephones) that must be installed by trained service technicians must use externally mounted antennas.

In general, it should be kept in mind that any additional electrical equipment installed must comply with the regulations in the country of use of the vehicle.

26.16 - Radiations

The vehicle, in conditions of normal use, does not produce any type of radiation, ionizing and non ionizing, that can cause problems to the operator.

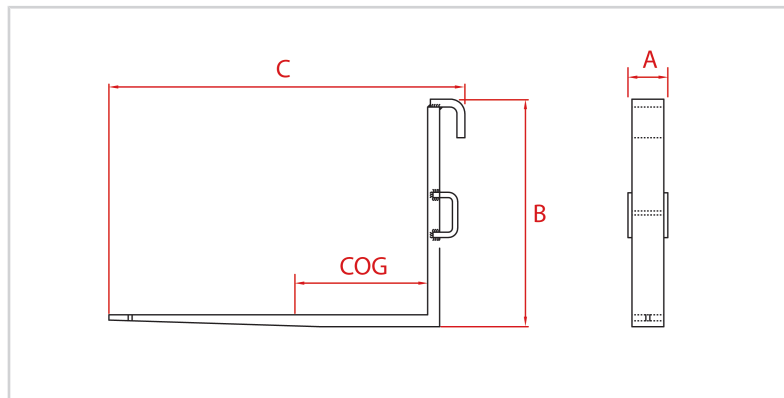
26.17 - Forks technical data

170221-1: Forks dimensions

NOTE! The dimensions indicated are for only one fork.

	BUD1060
Price list equipment code	TFR0001
Capacity	3800 kg (8378 lb)
Weight	82 kg (181 lb)
Width (A)	150 mm (5,9 in)
Height (B)	855 mm (33,7 in)
Length (C)	1340 mm (52,8 in)
COG	500 mm (19,7 in)
Width section	120 mm (4,7 in)
Height section	45 mm (1,8 in)
	BUD1187
Price list equipment code	TFR0010
Capacity	7500 kg (16535 lb)
Weight	140 kg (309 lb)
Width (A)	180 mm (7,1 in)
Height (B)	890 mm (35 in)
Length (C)	1375 mm (54,1 in)
COG	600 mm (23,6 in)
Width section	150 mm (5,9 in)
Height section	60 mm (2,4 in)

26.18 - Buckets technical data

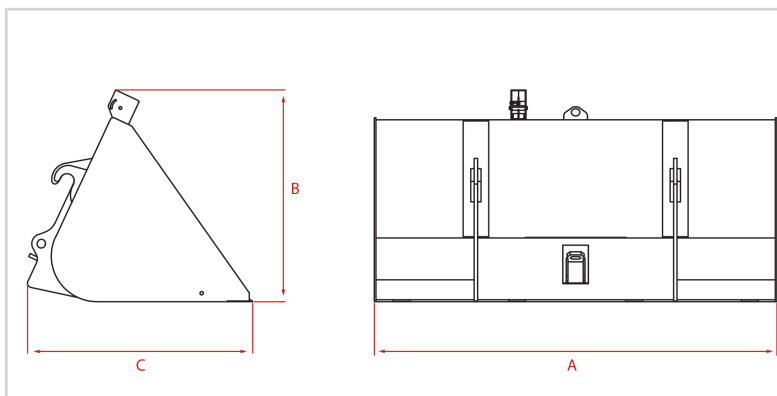

170220-1: Buckets dimensions

	BUB2464
Price list equipment code	TBN0037
SAE heap capacity	0,9 m ³ (32 ft ³)
Struck capacity	-
Maximum density	-
Type of use	-
Weight	405 kg (893 lb)
Width (A)	2370 mm (93,3 in)
Height (B)	890 mm (35 in)
Length (C)	937 mm (36,9 in)
Tooth code	-
Number of teeth	-
	BUB2465
Price list equipment code	TBN0039
SAE heap capacity	0,9 m ³ (32 ft ³)
Struck capacity	-
Maximum density	-
Type of use	-
Weight	425 kg (937 lb)
Width (A)	2370 mm (93,3 in)
Height (B)	890 mm (35 in)
Length (C)	937 mm (36,9 in)
Tooth code	-
Number of teeth	-
	BUB2635
Price list equipment code	TBN0047
SAE heap capacity	3 m ³ (106 ft ³)
Struck capacity	-
Maximum density	-
Type of use	-
Weight	620 kg (1367 lb)

	BUB2635
Width (A)	2370 mm (93,3 in)
Height (B)	1404 mm (55,3 in)
Length (C)	1519 mm (59,8 in)
Tooth code	-
Number of teeth	-



26.19 - Tyre data

VEHICLE PRICE	VEHICLE DESCRIPTION	Attachments	Brand	Size	Drawing	Front inflation pressure		
						bar	MPa	psi
MFO3517	SAMSON 75.10 - GD Stage V	Standard	AEOLUS	18-22.5	AGP23	7.9	0.79	115
MFO3518	AGRI MAX 75.10 - GD Stage V	Standard	AEOLUS	18-22.5	AGP23	7.9	0.79	115
MFO3517	SAMSON 75.10 - GD Stage V	Optional	Michelin	18-22.5	XF	7.5	0.75	109
MFO3518	AGRI MAX 75.10 - GD Stage V	Optional	Michelin	18-22.5	XF	7.5	0.75	109

Operating modes key

Codes have been used in the tables that indicate the vehicle and equipment combination in order to indicate the various operating modes on the vehicle.

Operating mode	Icons		Description
DIAG_M100		-	Only on wheels
DIAG_M200		-	Front outriggers (2) on wheels
DIAG_M201		-	Front outriggers (2), on feet
DIAG_M300			Flap down outriggers (4), on wheels with front turret (0°)
DIAG_M301			Flap down outriggers (4), on wheels with rotated turret (400°)
DIAG_M302			Flap down outriggers (4), on feet with rotated turret (400°)
DIAG_M400			Crossbeam outriggers (4), on wheels with front turret (0°)
DIAG_M401			Crossbeam outriggers (4), on wheels with rotated turret (0°)
DIAG_M402			Crossbeam outriggers (4), on 100% extended feet and turret in rotation (360°)
DIAG_M403			Crossbeam outriggers (4), on 50% extended feet and turret in rotation (360°)
DIAG_M404			Crossbeam outriggers (4), on 0% extended feet and turret in rotation (360°)
DIAG_M500			Flap down outriggers (4), on wheels with front turret (0°)
DIAG_M501			Flap down outriggers (4), on wheels with rotated turret (360°)
DIAG_M502			Flap down outriggers (4), on feet with front turret (0°)

Operating mode	Icons	Description
DIAG_M503	 	Flap down outriggers (4), on feet with rotated turret (360°)

How to read the equipment matching tables

The vehicle and equipment combinations are shown in the following tables and include the following cases:

Indication	Description
x	Load chart not necessary for vehicle and equipment use in the specified operating mode.
NO	It is not possible to use vehicle and equipment in the specified operating mode.
AXB0000 or DOCDI0000000	Load chart code of the vehicle and equipment in a specific operating mode.
N/D	Load chart not available.

27.1 - Diagrams Agri Max - Samson 75.10

Diagrams code	Vehicle code	Vehicle model	Production equipment code	Price list equipment code	Unit of measure	Operating Mode
DOCDI0000068	MFO3517 MFO3518	AGRI MAX 75.10 - GD	BUD1187	TFR0017	Metric	DIAG_M200
DOCDI0000069	MFO3517 MFO3518	SAMSON 75.10 - GD	BUD1187	TFR0017	Metric	DIAG_M201
DOCDI0000236	MFO3517 MFO3518	AGRI MAX 75.10 - GD	BUD1187	TFR0017	Imperial	DIAG_M200
DOCDI0000237	MFO3517 MFO3518	SAMSON 75.10 - GD	BUD1187	TFR0017	Imperial	DIAG_M201

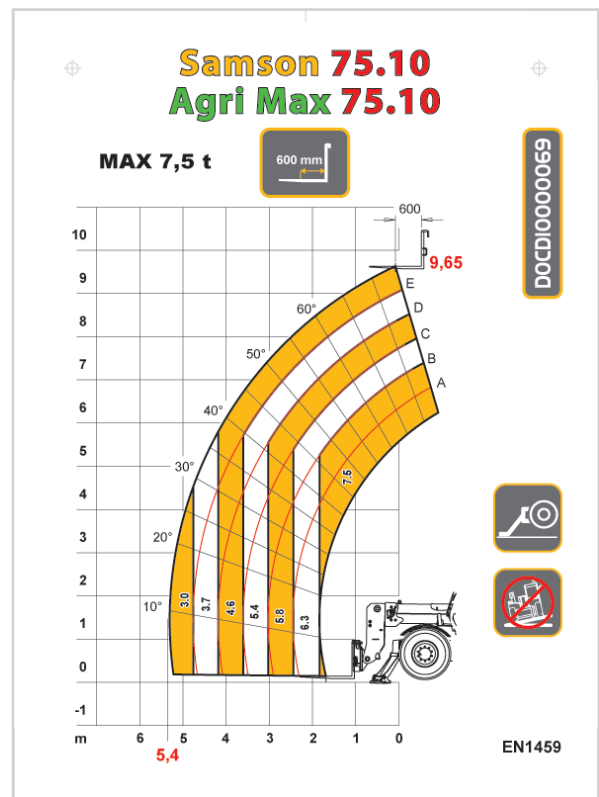
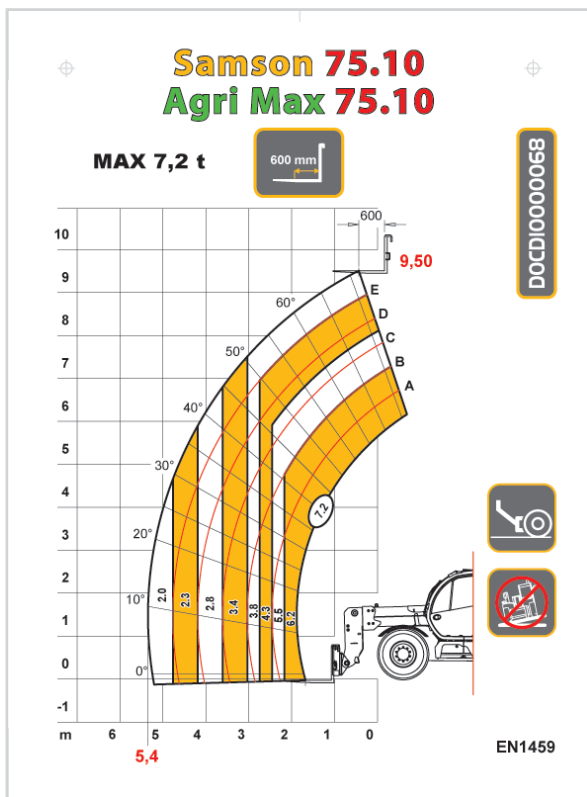

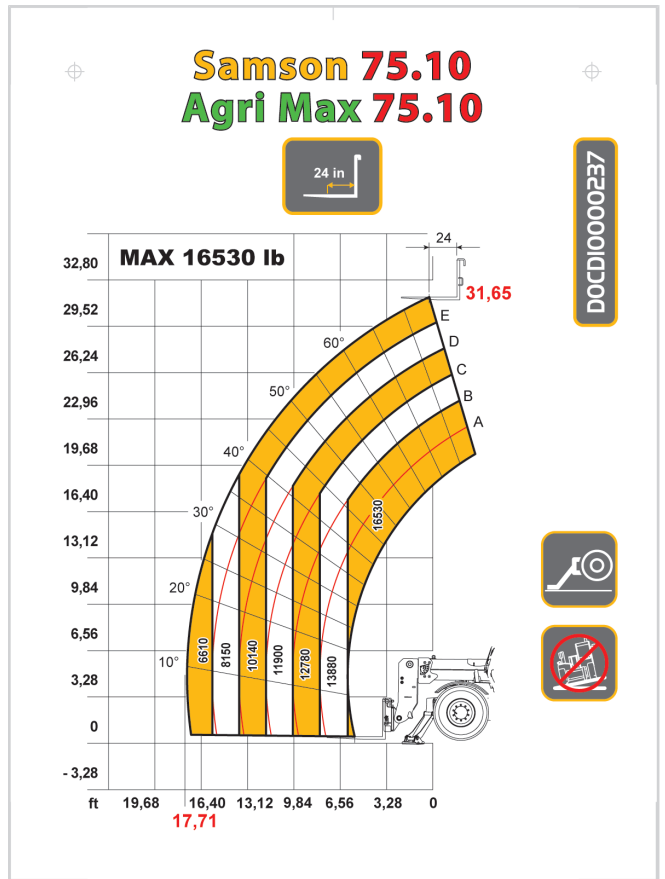
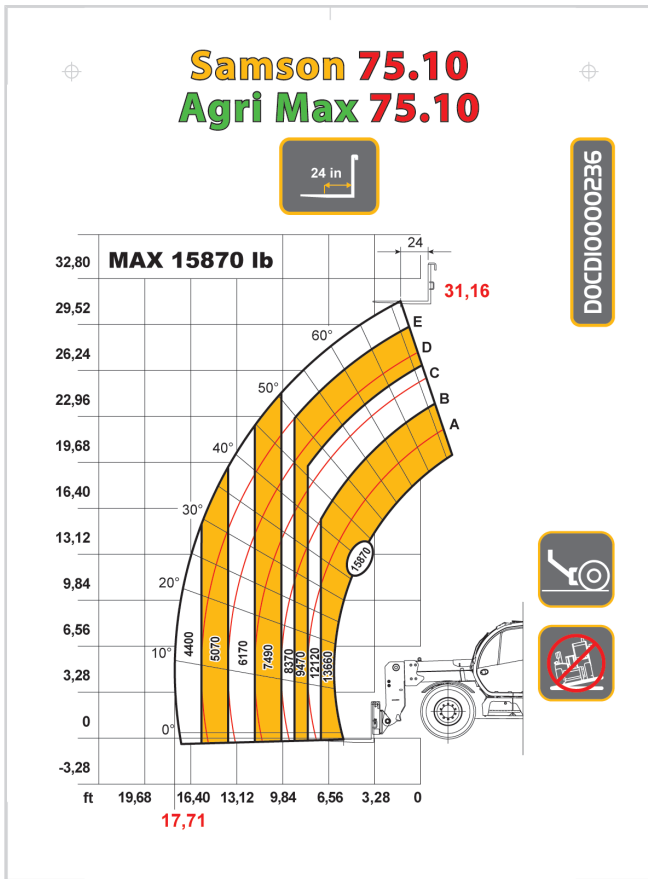

The Control Log and Maintenance Log are to be considered as integral parts of the vehicle and equipment. These logs must therefore accompany the vehicle and equipment for their life, to final disposal.

28.1 - Type of logs

28.1.1 - Control log

On the Control Log are recorded the main checks on the safety devices of the equipment, recommended by *Dieci S.r.l.*, with the related deadlines.

These checks ensure the proper operation of the safety devices.



NOTE

The checks specified in the Control Log are in addition to the routine maintenance described in the Maintenance Log.

28.1.2 - Maintenance Log

On the Maintenance Log are recorded all scheduled maintenance with timelines, referred to the use in normal, and not heavy, conditions. Such maintenance interventions allow to keep the vehicle or the equipment in the best efficiency conditions.

The scheduled maintenance intervals frequency must be reduced even to daily, if necessary, in particularly heavy working conditions (humidity, mud, sand, high dust level, etc ...).



NOTE

Consult the *DIECI* service center to establish appropriate timelines when working in particularly heavy environments.

28.2 - Instructions for compiling the logs

28.2.1 - Warnings on the control log

- The log must be prepared in accordance with the requirements imposed by the Essential Safety Requirement 4.4.2.b Annex I of the Machinery Directive 2006/42/EC, in order to preserve evidence of the proper conduct of all the inspection and maintenance activities concerning the vehicle safety.
- In the log, in addition to all the activities relating to the life, use and maintenance of safety systems of the vehicle (replacement of parts, overhauls, breakdowns, etc.) it is necessary to record all the checks required by the regulations in force in the country where the vehicle is used.
- It is also necessary that the name of the verifier technician and date of intervention are clearly identifiable.
- It is recommended to prepare, update and preserved with care, for the entire life of the vehicle or equipment, the control log.



NOTE

Here following there are some pages to allow compiling such logs.

Consult the Dieci s.r.l. service center to obtain more information regarding the availability of control and maintenance logs.

28.2.2 - Warnings on the maintenance log

- The maintenance log shall prevail for warranty claims. All activities relating to the life, use and maintenance of the vehicle must be registered in the log.

28.2.3 - Logs compiling

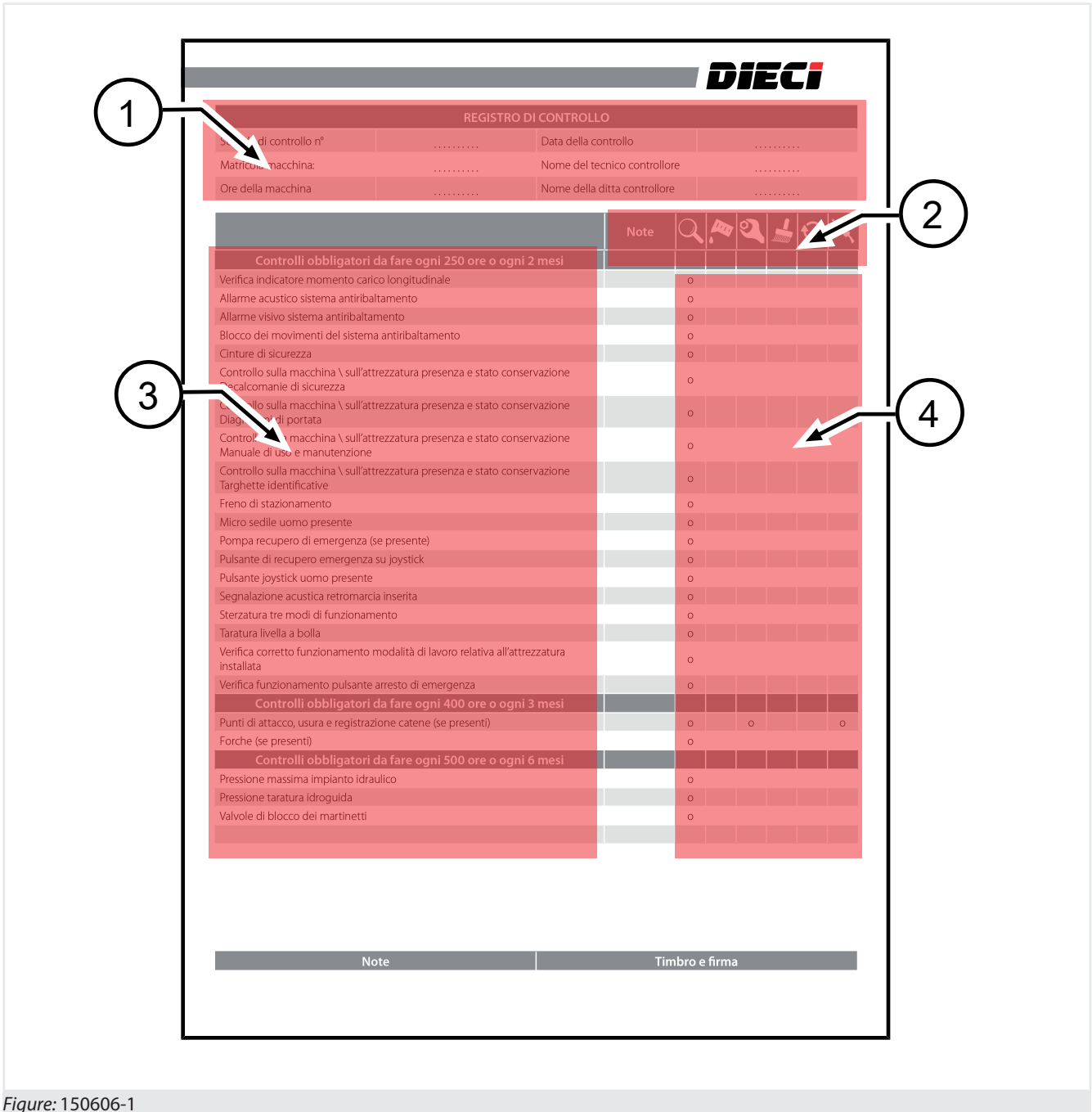









Figure: 150606-1

Each log (fig. 150606-1) requires the compilation of several parts:

1. Log data
2. Operations to carry out
3. Component or device on which to carry out the operation to be performed
4. Space that indicates the obligatory operation marked by the symbol "o", and the possibility to annotate an extraordinary operation not included in the log.

28.2.4 - Logs legend

Symbol	Description
	Control - Check
	Refilling
	Adjustment
	Cleaning
	Replacement
	Lubrication
	Maintenance at an authorized service center

28.2.5 - Intervals legend

**NOTE**

The intervals are defined both in hours of work and in time intervals from the date of purchase.

It is necessary to make interventions at the end of the first interval, either work hours or time.

Timelines	Description
0h	According to the need - To be completed in the case of checks not linked to deadlines but more or less related to the heavy operation of the vehicle
10h / 1m	Every 10 hours of operation or every month
50h / 1m	Every 50 hours of operation or every month
250h / 2m	Every 250 hours of operation or every 2 months
500h / 6m	Every 500 hours of operation or every 6 months
1000h / 1y	Every 1000 hours of operation or every year
2000h	Every 2000 hours of operation
4000h	Every 4000 hours of operation
2y	Every 2 years

28.3 - Periodic checks and recording mode (Italian only)

- The employer/operator of the vehicle is required to submit the vehicle to the periodic checks provided by law (Ministerial Decree 12/9/59 and Legislative Decree 81/08).
- He/she also has the obligation to comply with the maintenance and surveillance plan described in this Use and Maintenance Manual of the vehicle.
- The periodic inspection, testing and maintenance must be carried out by specialized personnel appointed for that purpose or by a workshop authorized by the manufacturer DIECI S.r.l.
- The employer/operator of the vehicle must record or appoint personnel trained for the purpose to record the results of the checks into the Control Log.
- Regular checks that have to be entered in the "Control log" are:
 - Quarterly periodic checks regarding the functionality and/or efficiency of ropes/chains according to Annex VI section 3.1.2 of Legislative Decree 81/08;
 - Yearly periodic checks regarding the operation and storage of the vehicle for safety purposes (yearly inspections, corrosion checks, calibration check, etc.) in accordance with Annex VII of Legislative Decree 81/08;
- The law provides administrative sanctions against those who do not carry out the quarterly and yearly checks.
- The Control Log, in which it is necessary to record the checks, must be shown upon request to the officials responsible for monitoring the current legislation.
- Following the yearly periodic check the Local Health Authority official (Dip.SSIA), or the private Enabled Party chosen, issues a suitability report or prescribes the necessary obligations. The user is obliged to preserve the check report together with the Control Log.
- The checks evaluation must be recorded in the following dedicated pages indicating the outcome of the check, date, signature and any comments of the party in charge.
- If the pages dedicated in this Manual are insufficient for the annotations made in the life of the vehicle, use additional sheets being careful to compile them in the same way.

28.4 - Obligation and how to report to I.N.A.I.L. (National institute for insurance against accidents at work) (Italy only)

- The Legislative Decree 81/08 - Annex VII prescribes the obligation, to employers and users of lifting equipment with motor with capacity > 200 kg and lifting platforms for persons, to report the successful commissioning to the competent authority of the territory of the vehicle (currently I.N.A.I.L.), specifying the place of installation of the vehicle so that the authority itself may carry out the first verification.
- The report to I.N.A.I.L. must be carried out by attaching to the vehicle commissioning report a copy of the EC Declaration of Conformity of machinery referred to in Annex IIA of the Legislative Decree 17/2010 - Machinery Directive 2006/42/ EC.
- The original statements (CE Declaration of Conformity - Annex IIA) must be retained by the customer.
- The report to I.N.A.I.L. may be sent by registered letter with return receipt.

28.5 - Control log







The following are some sheets for filling in the Control Log.

CONTROL LOG			
Control sheet no.	Control date
Vehicle serial number:	Controller technician name
Vehicle hours	Controller company name

	Maintenance							
250h / 2m	Seat belts	O						
250h / 2m	Control over the machine for the presence and status of conservation of Safety Stickers	O						
250h / 2m	Control over the machine for the presence and conservation status of the Use and maintenance manual	O						
250h / 2m	Control over the machine for the presence and conservation status of Identification labels	O						
250h / 2m	Parking brake	O						
250h / 2m	Deadman seat microswitch	O						
250h / 2m	Reverse gear engaged acoustic signal	O						
250h / 2m	Three operation mode steering	O						
250h / 2m	Travel permitted only with driving seat properly positioned forward or reversed	O						
250h / 2m	Emergency stop button	O						
500h / 6m	Hydraulic system maximum pressure	O						
500h / 6m	Power steering calibration pressure	O						

Notes	Stamp and signature

CONTROL LOG			
Control sheet no.	Control date
Vehicle serial number:	Controller technician name
Vehicle hours	Controller company name

Maintenance								
250h / 2m	Seat belts	<input type="checkbox"/>						
250h / 2m	Control over the machine for the presence and status of conservation of Safety Stickers	<input type="checkbox"/>						
250h / 2m	Control over the machine for the presence and conservation status of the Use and maintenance manual	<input type="checkbox"/>						
250h / 2m	Control over the machine for the presence and conservation status of Identification labels	<input type="checkbox"/>						
250h / 2m	Parking brake	<input type="checkbox"/>						
250h / 2m	Deadman seat microswitch	<input type="checkbox"/>						
250h / 2m	Reverse gear engaged acoustic signal	<input type="checkbox"/>						
250h / 2m	Three operation mode steering	<input type="checkbox"/>						
250h / 2m	Travel permitted only with driving seat properly positioned forward or reversed	<input type="checkbox"/>						
250h / 2m	Emergency stop button	<input type="checkbox"/>						
500h / 6m	Hydraulic system maximum pressure	<input type="checkbox"/>						
500h / 6m	Power steering calibration pressure	<input type="checkbox"/>						







Notes	Stamp and signature

CONTROL LOG			
Control sheet no.	Control date
Vehicle serial number:	Controller technician name
Vehicle hours	Controller company name

	Maintenance							
250h / 2m	Seat belts	O						
250h / 2m	Control over the machine for the presence and status of conservation of Safety Stickers	O						
250h / 2m	Control over the machine for the presence and conservation status of the Use and maintenance manual	O						
250h / 2m	Control over the machine for the presence and conservation status of Identification labels	O						
250h / 2m	Parking brake	O						
250h / 2m	Deadman seat microswitch	O						
250h / 2m	Reverse gear engaged acoustic signal	O						
250h / 2m	Three operation mode steering	O						
250h / 2m	Travel permitted only with driving seat properly positioned forward or reversed	O						
250h / 2m	Emergency stop button	O						
500h / 6m	Hydraulic system maximum pressure	O						
500h / 6m	Power steering calibration pressure	O						

Notes	Stamp and signature

CONTROL LOG			
Control sheet no.	Control date
Vehicle serial number:	Controller technician name
Vehicle hours	Controller company name

Maintenance								
250h / 2m	Seat belts	<input type="checkbox"/>						
250h / 2m	Control over the machine for the presence and status of conservation of Safety Stickers	<input type="checkbox"/>						
250h / 2m	Control over the machine for the presence and conservation status of the Use and maintenance manual	<input type="checkbox"/>						
250h / 2m	Control over the machine for the presence and conservation status of Identification labels	<input type="checkbox"/>						
250h / 2m	Parking brake	<input type="checkbox"/>						
250h / 2m	Deadman seat microswitch	<input type="checkbox"/>						
250h / 2m	Reverse gear engaged acoustic signal	<input type="checkbox"/>						
250h / 2m	Three operation mode steering	<input type="checkbox"/>						
250h / 2m	Travel permitted only with driving seat properly positioned forward or reversed	<input type="checkbox"/>						
250h / 2m	Emergency stop button	<input type="checkbox"/>						
500h / 6m	Hydraulic system maximum pressure	<input type="checkbox"/>						
500h / 6m	Power steering calibration pressure	<input type="checkbox"/>						







Notes	Stamp and signature

CONTROL LOG			
Control sheet no.	Control date
Vehicle serial number:	Controller technician name
Vehicle hours	Controller company name

	Maintenance							
250h / 2m	Seat belts	O						
250h / 2m	Control over the machine for the presence and status of conservation of Safety Stickers	O						
250h / 2m	Control over the machine for the presence and conservation status of the Use and maintenance manual	O						
250h / 2m	Control over the machine for the presence and conservation status of Identification labels	O						
250h / 2m	Parking brake	O						
250h / 2m	Deadman seat microswitch	O						
250h / 2m	Reverse gear engaged acoustic signal	O						
250h / 2m	Three operation mode steering	O						
250h / 2m	Travel permitted only with driving seat properly positioned forward or reversed	O						
250h / 2m	Emergency stop button	O						
500h / 6m	Hydraulic system maximum pressure	O						
500h / 6m	Power steering calibration pressure	O						

Notes	Stamp and signature

CONTROL LOG			
Control sheet no.	Control date
Vehicle serial number:	Controller technician name
Vehicle hours	Controller company name

	Maintenance							
250h / 2m	Seat belts	<input type="checkbox"/>						
250h / 2m	Control over the machine for the presence and status of conservation of Safety Stickers	<input type="checkbox"/>						
250h / 2m	Control over the machine for the presence and conservation status of the Use and maintenance manual	<input type="checkbox"/>						
250h / 2m	Control over the machine for the presence and conservation status of Identification labels	<input type="checkbox"/>						
250h / 2m	Parking brake	<input type="checkbox"/>						
250h / 2m	Deadman seat microswitch	<input type="checkbox"/>						
250h / 2m	Reverse gear engaged acoustic signal	<input type="checkbox"/>						
250h / 2m	Three operation mode steering	<input type="checkbox"/>						
250h / 2m	Travel permitted only with driving seat properly positioned forward or reversed	<input type="checkbox"/>						
250h / 2m	Emergency stop button	<input type="checkbox"/>						
500h / 6m	Hydraulic system maximum pressure	<input type="checkbox"/>						
500h / 6m	Power steering calibration pressure	<input type="checkbox"/>						







Notes	Stamp and signature

CONTROL LOG			
Control sheet no.	Control date
Vehicle serial number:	Controller technician name
Vehicle hours	Controller company name

	Maintenance							
250h / 2m	Seat belts	O						
250h / 2m	Control over the machine for the presence and status of conservation of Safety Stickers	O						
250h / 2m	Control over the machine for the presence and conservation status of the Use and maintenance manual	O						
250h / 2m	Control over the machine for the presence and conservation status of Identification labels	O						
250h / 2m	Parking brake	O						
250h / 2m	Deadman seat microswitch	O						
250h / 2m	Reverse gear engaged acoustic signal	O						
250h / 2m	Three operation mode steering	O						
250h / 2m	Travel permitted only with driving seat properly positioned forward or reversed	O						
250h / 2m	Emergency stop button	O						
500h / 6m	Hydraulic system maximum pressure	O						
500h / 6m	Power steering calibration pressure	O						

Notes	Stamp and signature

CONTROL LOG			
Control sheet no.	Control date
Vehicle serial number:	Controller technician name
Vehicle hours	Controller company name

Maintenance								
250h / 2m	Seat belts	<input type="checkbox"/>						
250h / 2m	Control over the machine for the presence and status of conservation of Safety Stickers	<input type="checkbox"/>						
250h / 2m	Control over the machine for the presence and conservation status of the Use and maintenance manual	<input type="checkbox"/>						
250h / 2m	Control over the machine for the presence and conservation status of Identification labels	<input type="checkbox"/>						
250h / 2m	Parking brake	<input type="checkbox"/>						
250h / 2m	Deadman seat microswitch	<input type="checkbox"/>						
250h / 2m	Reverse gear engaged acoustic signal	<input type="checkbox"/>						
250h / 2m	Three operation mode steering	<input type="checkbox"/>						
250h / 2m	Travel permitted only with driving seat properly positioned forward or reversed	<input type="checkbox"/>						
250h / 2m	Emergency stop button	<input type="checkbox"/>						
500h / 6m	Hydraulic system maximum pressure	<input type="checkbox"/>						
500h / 6m	Power steering calibration pressure	<input type="checkbox"/>						







Notes	Stamp and signature

CONTROL LOG			
Control sheet no.	Control date
Vehicle serial number:	Controller technician name
Vehicle hours	Controller company name

Maintenance								
250h / 2m	Seat belts	O						
250h / 2m	Control over the machine for the presence and status of conservation of Safety Stickers	O						
250h / 2m	Control over the machine for the presence and conservation status of the Use and maintenance manual	O						
250h / 2m	Control over the machine for the presence and conservation status of Identification labels	O						
250h / 2m	Parking brake	O						
250h / 2m	Deadman seat microswitch	O						
250h / 2m	Reverse gear engaged acoustic signal	O						
250h / 2m	Three operation mode steering	O						
250h / 2m	Travel permitted only with driving seat properly positioned forward or reversed	O						
250h / 2m	Emergency stop button	O						
500h / 6m	Hydraulic system maximum pressure	O						
500h / 6m	Power steering calibration pressure	O						

Notes	Stamp and signature

CONTROL LOG			
Control sheet no.	Control date
Vehicle serial number:	Controller technician name
Vehicle hours	Controller company name







	Maintenance							
250h / 2m	Seat belts	<input type="checkbox"/>						
250h / 2m	Control over the machine for the presence and status of conservation of Safety Stickers	<input type="checkbox"/>						
250h / 2m	Control over the machine for the presence and conservation status of the Use and maintenance manual	<input type="checkbox"/>						
250h / 2m	Control over the machine for the presence and conservation status of Identification labels	<input type="checkbox"/>						
250h / 2m	Parking brake	<input type="checkbox"/>						
250h / 2m	Deadman seat microswitch	<input type="checkbox"/>						
250h / 2m	Reverse gear engaged acoustic signal	<input type="checkbox"/>						
250h / 2m	Three operation mode steering	<input type="checkbox"/>						
250h / 2m	Travel permitted only with driving seat properly positioned forward or reversed	<input type="checkbox"/>						
250h / 2m	Emergency stop button	<input type="checkbox"/>						
500h / 6m	Hydraulic system maximum pressure	<input type="checkbox"/>						
500h / 6m	Power steering calibration pressure	<input type="checkbox"/>						







Notes	Stamp and signature







28.6 - Maintenance log

The following are some sheets for filling in the Maintenance Log.

MAINTENANCE LOG			
Maintenance sheet no.	Maintenance date
Vehicle serial number:	Maintenance technician name
Vehicle hours	Maintenance company name







	Maintenance							
0h	Air conditioning system	<input type="checkbox"/>			<input type="checkbox"/>			
0h	Filters (air, engine oil, hydraulic oil, fuel, air conditioning system, cab)	<input type="checkbox"/>						
0h	Brake			<input type="checkbox"/>				
0h	Parking brake	<input type="checkbox"/>						
0h	Electrolyte level and battery charge	<input type="checkbox"/>						
0h	Lighting	<input type="checkbox"/>						
0h	Hydraulic oil level	<input type="checkbox"/>						
0h	Alternator belts \ services	<input type="checkbox"/>						
0h	Engine oil level	<input type="checkbox"/>						
0h	Radiators	<input type="checkbox"/>			<input type="checkbox"/>			
0h	Radiator expansion tank	<input type="checkbox"/>	<input type="checkbox"/>					
0h	Tyre pressure	<input type="checkbox"/>						
0h	Wear check (on both the vehicle and equipment if installed)	<input type="checkbox"/>						
10h / 1m	Window washer tank	<input type="checkbox"/>	<input type="checkbox"/>					
10h / 1m	Safety stickers	<input type="checkbox"/>						
10h / 1m	Safety devices	<input type="checkbox"/>						
10h / 1m	Coolant	<input type="checkbox"/>						
10h / 1m	Engine oil level	<input type="checkbox"/>						
10h / 1m	Metal structural work, no cracks	<input type="checkbox"/>						
10h / 1m	Radiators				<input type="checkbox"/>			
50h / 1m	Grease level in the automatic lubrication system (if installed)						<input type="checkbox"/>	
50h / 1m	Prop shafts						<input type="checkbox"/>	
50h / 1m	Axles oscillation						<input type="checkbox"/>	
50h / 1m	Wheels reduction gear pins						<input type="checkbox"/>	
50h / 1m	Mechanical joints of parking brake on the axle						<input type="checkbox"/>	
50h / 1m	Mechanical joints						<input type="checkbox"/>	
50h / 1m	Cab ventilation filter (if the closed cab option is present)				<input type="checkbox"/>			
50h / 1m	Brakes oil level	<input type="checkbox"/>						
50h / 1m	Hydraulic oil level	<input type="checkbox"/>						
50h / 1m	Hydraulic system leaks	<input type="checkbox"/>						
50h / 1m	Air filter				<input type="checkbox"/>			
50h / 1m	Fuel filter				<input type="checkbox"/>			
50h / 1m	Coolant	<input type="checkbox"/>						
50h / 1m	Engine oil level	<input type="checkbox"/>						
50h / 1m	Tyre pressure	<input type="checkbox"/>						

	Maintenance							
50h / 1m	Wheel nuts tightening	o						
250h / 2m	Seat belts	o						
250h / 2m	Rear view mirrors	o						
250h / 2m	Electrolyte level and battery charge	o						
250h / 2m	Torque specifications - Hydraulic Fittings			o				
250h / 2m	Alternator belts \ services	o		o				
250h / 2m	Torque specifications - fasteners			o				
250h	Transmission oil					o		
250h	Differential axle oil					o		
250h	Epicycloidal reduction gear oil					o		
500h / 6m	Differential axle oil	o						
500h / 6m	Epicycloidal reduction gear oil	o						
500h / 6m	Cab ventilation filter (if the closed cab option is present)					o		
500h / 6m	Brakes oil					o		
500h / 6m	Electrical system	o						
500h / 6m	Hydraulic oil filter(s)					o		
500h / 6m	Air filter					o		
500h / 6m	Engine fuel filter					o		
500h / 6m	Engine oil filter					o		
500h / 6m	Engine oil					o		
500h / 6m	Drum gearbox oil	o						
500h / 6m	Transmission oil	o						
500h / 1y	Water separator filter					o		
1000h / 1y	Differential axle oil					o		
1000h / 1y	Epicycloidal reduction gear oil					o		
1000h / 1y	Cab structure	o						**
1000h / 1y	Brakes oil circuit				o			**
1000h / 1y	Brakes oil circuit: Pressure	o						**
1000h / 1y	Brake			o				**
1000h / 1y	Electrical system: cables condition	o						**
1000h / 1y	Electrical system: Lighting and signalling	o						**
1000h / 1y	Electrical system: Acoustic signal devices	o						**
1000h / 1y	Hydraulic system: Jacks	o						**
1000h / 1y	Hydraulic system: Pipes and flexible pipes	o						**
1000h / 1y	Hydraulic system: Movements speed	o						**
1000h / 1y	Hydraulic oil					o		
1000h / 1y	Engine valves clearances	o						**
1000h / 1y	Engine speeds	o						**
1000h / 1y	Fuel tank				o			
1000h / 1y	Drum gearbox oil					o		
1000h / 1y	Chassis: bearings and pivot bushes	o						**
1000h / 1y	Chassis: structure	o						**
1000h / 1y	Transmission oil					o		

Maintenance								
2000h	Axles oscillation	o						**
2000h	Hydraulic system: Capacity	o						**
2000h	Hydraulic system: Pressures	o						**
2000h	Hydraulic oil tank				o			**
2000h	Alternator and Starter motor	o						**
2000h	Radiators	o			o			**
3000h	Diesel exhaust fluid filter					o		
3000h	Coolant					o		
3600h	Engine AdBlue tank filter					o		**
4000h	Prop shafts	o				o		**
4000h	Reduction gears universal joint	o						**
4000h	Wheels reduction gear clearance	o						**
4000h	Steering ball joints	o						**
4000h	Wheels reduction gear pins	o						**
4000h	Brakes wear	o						**
10000h	DEF collector filter					o		
2y	Air conditioning system (if installed): Dissipater filter					o		**
2y	Air conditioning system (if installed): Oil refrigerant	o						**
2y	Air conditioning system (if installed): Pressure switches	o		o				**
2y	Air conditioning system (if installed): Condenser and evaporator coils				o			**
2y	Air conditioning system (if installed): Condensate and exhaust valve tank				o			**
Notes		Stamp and signature						

MAINTENANCE LOG			
Maintenance sheet no.	Maintenance date
Vehicle serial number:	Maintenance name	technician
Vehicle hours	Maintenance name	company







	Maintenance							
0h	Air conditioning system	<input type="radio"/>			<input type="radio"/>			
0h	Filters (air, engine oil, hydraulic oil, fuel, air conditioning system, cab)	<input type="radio"/>						
0h	Brake			<input type="radio"/>				
0h	Parking brake	<input type="radio"/>						
0h	Electrolyte level and battery charge	<input type="radio"/>						
0h	Lighting	<input type="radio"/>						
0h	Hydraulic oil level	<input type="radio"/>						
0h	Alternator belts \ services	<input type="radio"/>						
0h	Engine oil level	<input type="radio"/>						
0h	Radiators	<input type="radio"/>			<input type="radio"/>			
0h	Radiator expansion tank	<input type="radio"/>	<input type="radio"/>					
0h	Tyre pressure	<input type="radio"/>						
0h	Wear check (on both the vehicle and equipment if installed)	<input type="radio"/>						
10h / 1m	Window washer tank	<input type="radio"/>	<input type="radio"/>					
10h / 1m	Safety stickers	<input type="radio"/>						
10h / 1m	Safety devices	<input type="radio"/>						
10h / 1m	Coolant	<input type="radio"/>						
10h / 1m	Engine oil level	<input type="radio"/>						
10h / 1m	Metal structural work, no cracks	<input type="radio"/>						
10h / 1m	Radiators				<input type="radio"/>			
50h / 1m	Grease level in the automatic lubrication system (if installed)							<input type="radio"/>
50h / 1m	Prop shafts							<input type="radio"/>
50h / 1m	Axles oscillation							<input type="radio"/>
50h / 1m	Wheels reduction gear pins							<input type="radio"/>
50h / 1m	Mechanical joints of parking brake on the axle							<input type="radio"/>
50h / 1m	Mechanical joints							<input type="radio"/>
50h / 1m	Cab ventilation filter (if the closed cab option is present)				<input type="radio"/>			
50h / 1m	Brakes oil level	<input type="radio"/>						
50h / 1m	Hydraulic oil level	<input type="radio"/>						
50h / 1m	Hydraulic system leaks	<input type="radio"/>						
50h / 1m	Air filter				<input type="radio"/>			
50h / 1m	Fuel filter				<input type="radio"/>			
50h / 1m	Coolant	<input type="radio"/>						
50h / 1m	Engine oil level	<input type="radio"/>						
50h / 1m	Tyre pressure	<input type="radio"/>						







Maintenance								
50h / 1m	Wheel nuts tightening	o						
250h / 2m	Seat belts	o						
250h / 2m	Rear view mirrors	o						
250h / 2m	Electrolyte level and battery charge	o						
250h / 2m	Torque specifications - Hydraulic Fittings			o				
250h / 2m	Alternator belts \ services	o		o				
250h / 2m	Torque specifications - fasteners			o				
250h	Transmission oil					o		
250h	Differential axle oil					o		
250h	Epicycloidal reduction gear oil					o		
500h / 6m	Differential axle oil	o						
500h / 6m	Epicycloidal reduction gear oil	o						
500h / 6m	Cab ventilation filter (if the closed cab option is present)					o		
500h / 6m	Brakes oil					o		
500h / 6m	Electrical system	o						
500h / 6m	Hydraulic oil filter(s)					o		
500h / 6m	Air filter					o		
500h / 6m	Engine fuel filter					o		
500h / 6m	Engine oil filter					o		
500h / 6m	Engine oil					o		
500h / 6m	Drum gearbox oil	o						
500h / 6m	Transmission oil	o						
500h / 1y	Water separator filter					o		
1000h / 1y	Differential axle oil					o		
1000h / 1y	Epicycloidal reduction gear oil					o		
1000h / 1y	Cab structure	o						**
1000h / 1y	Brakes oil circuit				o			**
1000h / 1y	Brakes oil circuit: Pressure	o						**
1000h / 1y	Brake			o				**
1000h / 1y	Electrical system: cables condition	o						**
1000h / 1y	Electrical system: Lighting and signalling	o						**
1000h / 1y	Electrical system: Acoustic signal devices	o						**
1000h / 1y	Hydraulic system: Jacks	o						**
1000h / 1y	Hydraulic system: Pipes and flexible pipes	o						**







Maintenance								
1000h / 1y	Hydraulic system: Movements speed	o						**
1000h / 1y	Hydraulic oil					o		
1000h / 1y	Engine valves clearances	o						**
1000h / 1y	Engine speeds	o						**
1000h / 1y	Fuel tank				o			
1000h / 1y	Drum gearbox oil					o		
1000h / 1y	Chassis: bearings and pivot bushes	o						**
1000h / 1y	Chassis: structure	o						**
1000h / 1y	Transmission oil					o		
2000h	Axles oscillation	o						**
2000h	Hydraulic system: Capacity	o						**
2000h	Hydraulic system: Pressures	o						**
2000h	Hydraulic oil tank				o			**
2000h	Alternator and Starter motor	o						**
2000h	Radiators	o			o			**
3000h	Diesel exhaust fluid filter					o		
3000h	Coolant					o		
3600h	Engine AdBlue tank filter					o		**
4000h	Prop shafts	o				o		**
4000h	Reduction gears universal joint	o						**
4000h	Wheels reduction gear clearance	o						**
4000h	Steering ball joints	o						**
4000h	Wheels reduction gear pins	o						**
4000h	Brakes wear	o						**
10000h	DEF collector filter					o		
2y	Air conditioning system (if installed): Dissipater filter					o		**
2y	Air conditioning system (if installed): Oil refrigerant	o						**
2y	Air conditioning system (if installed): Pressure switches	o		o				**
2y	Air conditioning system (if installed): Condenser and evaporator coils				o			**
2y	Air conditioning system (if installed): Condensate and exhaust valve tank				o			**

Notes	Stamp and signature

MAINTENANCE LOG			
Maintenance sheet no.	Maintenance date
Vehicle serial number:	Maintenance technician name
Vehicle hours	Maintenance company name







	Maintenance							
0h	Air conditioning system	o			o			
0h	Filters (air, engine oil, hydraulic oil, fuel, air conditioning system, cab)	o						
0h	Brake			o				
0h	Parking brake	o						
0h	Electrolyte level and battery charge	o						
0h	Lighting	o						
0h	Hydraulic oil level	o						
0h	Alternator belts \ services	o						
0h	Engine oil level	o						
0h	Radiators	o			o			
0h	Radiator expansion tank	o	o					
0h	Tyre pressure	o						
0h	Wear check (on both the vehicle and equipment if installed)	o						
10h / 1m	Window washer tank	o	o					
10h / 1m	Safety stickers	o						
10h / 1m	Safety devices	o						
10h / 1m	Coolant	o						
10h / 1m	Engine oil level	o						
10h / 1m	Metal structural work, no cracks	o						
10h / 1m	Radiators				o			
50h / 1m	Grease level in the automatic lubrication system (if installed)						o	
50h / 1m	Prop shafts						o	
50h / 1m	Axles oscillation						o	
50h / 1m	Wheels reduction gear pins						o	
50h / 1m	Mechanical joints of parking brake on the axle						o	
50h / 1m	Mechanical joints						o	
50h / 1m	Cab ventilation filter (if the closed cab option is present)				o			
50h / 1m	Brakes oil level	o						
50h / 1m	Hydraulic oil level	o						
50h / 1m	Hydraulic system leaks	o						
50h / 1m	Air filter				o			
50h / 1m	Fuel filter				o			
50h / 1m	Coolant	o						
50h / 1m	Engine oil level	o						
50h / 1m	Tyre pressure	o						

	Maintenance							
50h / 1m	Wheel nuts tightening	o						
250h / 2m	Seat belts	o						
250h / 2m	Rear view mirrors	o						
250h / 2m	Electrolyte level and battery charge	o						
250h / 2m	Torque specifications - Hydraulic Fittings			o				
250h / 2m	Alternator belts \ services	o		o				
250h / 2m	Torque specifications - fasteners			o				
250h	Transmission oil					o		
250h	Differential axle oil					o		
250h	Epicycloidal reduction gear oil					o		
500h / 6m	Differential axle oil	o						
500h / 6m	Epicycloidal reduction gear oil	o						
500h / 6m	Cab ventilation filter (if the closed cab option is present)					o		
500h / 6m	Brakes oil					o		
500h / 6m	Electrical system	o						
500h / 6m	Hydraulic oil filter(s)					o		
500h / 6m	Air filter					o		
500h / 6m	Engine fuel filter					o		
500h / 6m	Engine oil filter					o		
500h / 6m	Engine oil					o		
500h / 6m	Drum gearbox oil	o						
500h / 6m	Transmission oil	o						
500h / 1y	Water separator filter					o		
1000h / 1y	Differential axle oil					o		
1000h / 1y	Epicycloidal reduction gear oil					o		
1000h / 1y	Cab structure	o						**
1000h / 1y	Brakes oil circuit				o			**
1000h / 1y	Brakes oil circuit: Pressure	o						**
1000h / 1y	Brake			o				**
1000h / 1y	Electrical system: cables condition	o						**
1000h / 1y	Electrical system: Lighting and signalling	o						**
1000h / 1y	Electrical system: Acoustic signal devices	o						**
1000h / 1y	Hydraulic system: Jacks	o						**
1000h / 1y	Hydraulic system: Pipes and flexible pipes	o						**
1000h / 1y	Hydraulic system: Movements speed	o						**
1000h / 1y	Hydraulic oil					o		
1000h / 1y	Engine valves clearances	o						**
1000h / 1y	Engine speeds	o						**
1000h / 1y	Fuel tank				o			
1000h / 1y	Drum gearbox oil					o		
1000h / 1y	Chassis: bearings and pivot bushes	o						**
1000h / 1y	Chassis: structure	o						**
1000h / 1y	Transmission oil					o		

Maintenance								
2000h	Axles oscillation	o						**
2000h	Hydraulic system: Capacity	o						**
2000h	Hydraulic system: Pressures	o						**
2000h	Hydraulic oil tank				o			**
2000h	Alternator and Starter motor	o						**
2000h	Radiators	o			o			**
3000h	Diesel exhaust fluid filter					o		
3000h	Coolant					o		
3600h	Engine AdBlue tank filter					o		**
4000h	Prop shafts	o				o		**
4000h	Reduction gears universal joint	o						**
4000h	Wheels reduction gear clearance	o						**
4000h	Steering ball joints	o						**
4000h	Wheels reduction gear pins	o						**
4000h	Brakes wear	o						**
10000h	DEF collector filter					o		
2y	Air conditioning system (if installed): Dissipater filter					o		**
2y	Air conditioning system (if installed): Oil refrigerant	o						**
2y	Air conditioning system (if installed): Pressure switches	o		o				**
2y	Air conditioning system (if installed): Condenser and evaporator coils				o			**
2y	Air conditioning system (if installed): Condensate and exhaust valve tank				o			**
Notes		Stamp and signature						

MAINTENANCE LOG			
Maintenance sheet no.	Maintenance date
Vehicle serial number:	Maintenance technician name
Vehicle hours	Maintenance company name







	Maintenance							
0h	Air conditioning system	<input type="radio"/>			<input type="radio"/>			
0h	Filters (air, engine oil, hydraulic oil, fuel, air conditioning system, cab)	<input type="radio"/>						
0h	Brake			<input type="radio"/>				
0h	Parking brake	<input type="radio"/>						
0h	Electrolyte level and battery charge	<input type="radio"/>						
0h	Lighting	<input type="radio"/>						
0h	Hydraulic oil level	<input type="radio"/>						
0h	Alternator belts \ services	<input type="radio"/>						
0h	Engine oil level	<input type="radio"/>						
0h	Radiators	<input type="radio"/>			<input type="radio"/>			
0h	Radiator expansion tank	<input type="radio"/>	<input type="radio"/>					
0h	Tyre pressure	<input type="radio"/>						
0h	Wear check (on both the vehicle and equipment if installed)	<input type="radio"/>						
10h / 1m	Window washer tank	<input type="radio"/>	<input type="radio"/>					
10h / 1m	Safety stickers	<input type="radio"/>						
10h / 1m	Safety devices	<input type="radio"/>						
10h / 1m	Coolant	<input type="radio"/>						
10h / 1m	Engine oil level	<input type="radio"/>						
10h / 1m	Metal structural work, no cracks	<input type="radio"/>						
10h / 1m	Radiators				<input type="radio"/>			
50h / 1m	Grease level in the automatic lubrication system (if installed)							<input type="radio"/>
50h / 1m	Prop shafts							<input type="radio"/>
50h / 1m	Axles oscillation							<input type="radio"/>
50h / 1m	Wheels reduction gear pins							<input type="radio"/>
50h / 1m	Mechanical joints of parking brake on the axle							<input type="radio"/>
50h / 1m	Mechanical joints							<input type="radio"/>
50h / 1m	Cab ventilation filter (if the closed cab option is present)				<input type="radio"/>			
50h / 1m	Brakes oil level	<input type="radio"/>						
50h / 1m	Hydraulic oil level	<input type="radio"/>						
50h / 1m	Hydraulic system leaks	<input type="radio"/>						
50h / 1m	Air filter				<input type="radio"/>			
50h / 1m	Fuel filter				<input type="radio"/>			
50h / 1m	Coolant	<input type="radio"/>						
50h / 1m	Engine oil level	<input type="radio"/>						
50h / 1m	Tyre pressure	<input type="radio"/>						







Maintenance								
50h / 1m	Wheel nuts tightening	o						
250h / 2m	Seat belts	o						
250h / 2m	Rear view mirrors	o						
250h / 2m	Electrolyte level and battery charge	o						
250h / 2m	Torque specifications - Hydraulic Fittings			o				
250h / 2m	Alternator belts \ services	o		o				
250h / 2m	Torque specifications - fasteners			o				
250h	Transmission oil					o		
250h	Differential axle oil					o		
250h	Epicycloidal reduction gear oil					o		
500h / 6m	Differential axle oil	o						
500h / 6m	Epicycloidal reduction gear oil	o						
500h / 6m	Cab ventilation filter (if the closed cab option is present)					o		
500h / 6m	Brakes oil					o		
500h / 6m	Electrical system	o						
500h / 6m	Hydraulic oil filter(s)					o		
500h / 6m	Air filter					o		
500h / 6m	Engine fuel filter					o		
500h / 6m	Engine oil filter					o		
500h / 6m	Engine oil					o		
500h / 6m	Drum gearbox oil	o						
500h / 6m	Transmission oil	o						
500h / 1y	Water separator filter					o		
1000h / 1y	Differential axle oil					o		
1000h / 1y	Epicycloidal reduction gear oil					o		
1000h / 1y	Cab structure	o						**
1000h / 1y	Brakes oil circuit				o			**
1000h / 1y	Brakes oil circuit: Pressure	o						**
1000h / 1y	Brake			o				**
1000h / 1y	Electrical system: cables condition	o						**
1000h / 1y	Electrical system: Lighting and signalling	o						**
1000h / 1y	Electrical system: Acoustic signal devices	o						**
1000h / 1y	Hydraulic system: Jacks	o						**
1000h / 1y	Hydraulic system: Pipes and flexible pipes	o						**







Maintenance								
1000h / 1y	Hydraulic system: Movements speed	o						**
1000h / 1y	Hydraulic oil					o		
1000h / 1y	Engine valves clearances	o						**
1000h / 1y	Engine speeds	o						**
1000h / 1y	Fuel tank				o			
1000h / 1y	Drum gearbox oil					o		
1000h / 1y	Chassis: bearings and pivot bushes	o						**
1000h / 1y	Chassis: structure	o						**
1000h / 1y	Transmission oil					o		
2000h	Axles oscillation	o						**
2000h	Hydraulic system: Capacity	o						**
2000h	Hydraulic system: Pressures	o						**
2000h	Hydraulic oil tank				o			**
2000h	Alternator and Starter motor	o						**
2000h	Radiators	o			o			**
3000h	Diesel exhaust fluid filter					o		
3000h	Coolant					o		
3600h	Engine AdBlue tank filter					o		**
4000h	Prop shafts	o				o		**
4000h	Reduction gears universal joint	o						**
4000h	Wheels reduction gear clearance	o						**
4000h	Steering ball joints	o						**
4000h	Wheels reduction gear pins	o						**
4000h	Brakes wear	o						**
10000h	DEF collector filter					o		
2y	Air conditioning system (if installed): Dissipater filter					o		**
2y	Air conditioning system (if installed): Oil refrigerant	o						**
2y	Air conditioning system (if installed): Pressure switches	o		o				**
2y	Air conditioning system (if installed): Condenser and evaporator coils				o			**
2y	Air conditioning system (if installed): Condensate and exhaust valve tank				o			**

Notes	Stamp and signature

MAINTENANCE LOG			
Maintenance sheet no.	Maintenance date
Vehicle serial number:	Maintenance technician name
Vehicle hours	Maintenance company name







	Maintenance							
0h	Air conditioning system	o			o			
0h	Filters (air, engine oil, hydraulic oil, fuel, air conditioning system, cab)	o						
0h	Brake			o				
0h	Parking brake	o						
0h	Electrolyte level and battery charge	o						
0h	Lighting	o						
0h	Hydraulic oil level	o						
0h	Alternator belts \ services	o						
0h	Engine oil level	o						
0h	Radiators	o			o			
0h	Radiator expansion tank	o	o					
0h	Tyre pressure	o						
0h	Wear check (on both the vehicle and equipment if installed)	o						
10h / 1m	Window washer tank	o	o					
10h / 1m	Safety stickers	o						
10h / 1m	Safety devices	o						
10h / 1m	Coolant	o						
10h / 1m	Engine oil level	o						
10h / 1m	Metal structural work, no cracks	o						
10h / 1m	Radiators				o			
50h / 1m	Grease level in the automatic lubrication system (if installed)						o	
50h / 1m	Prop shafts						o	
50h / 1m	Axles oscillation						o	
50h / 1m	Wheels reduction gear pins						o	
50h / 1m	Mechanical joints of parking brake on the axle						o	
50h / 1m	Mechanical joints						o	
50h / 1m	Cab ventilation filter (if the closed cab option is present)				o			
50h / 1m	Brakes oil level	o						
50h / 1m	Hydraulic oil level	o						
50h / 1m	Hydraulic system leaks	o						
50h / 1m	Air filter				o			
50h / 1m	Fuel filter				o			
50h / 1m	Coolant	o						
50h / 1m	Engine oil level	o						
50h / 1m	Tyre pressure	o						

	Maintenance							
50h / 1m	Wheel nuts tightening	o						
250h / 2m	Seat belts	o						
250h / 2m	Rear view mirrors	o						
250h / 2m	Electrolyte level and battery charge	o						
250h / 2m	Torque specifications - Hydraulic Fittings			o				
250h / 2m	Alternator belts \ services	o		o				
250h / 2m	Torque specifications - fasteners			o				
250h	Transmission oil					o		
250h	Differential axle oil					o		
250h	Epicycloidal reduction gear oil					o		
500h / 6m	Differential axle oil	o						
500h / 6m	Epicycloidal reduction gear oil	o						
500h / 6m	Cab ventilation filter (if the closed cab option is present)					o		
500h / 6m	Brakes oil					o		
500h / 6m	Electrical system	o						
500h / 6m	Hydraulic oil filter(s)					o		
500h / 6m	Air filter					o		
500h / 6m	Engine fuel filter					o		
500h / 6m	Engine oil filter					o		
500h / 6m	Engine oil					o		
500h / 6m	Drum gearbox oil	o						
500h / 6m	Transmission oil	o						
500h / 1y	Water separator filter					o		
1000h / 1y	Differential axle oil					o		
1000h / 1y	Epicycloidal reduction gear oil					o		
1000h / 1y	Cab structure	o						**
1000h / 1y	Brakes oil circuit				o			**
1000h / 1y	Brakes oil circuit: Pressure	o						**
1000h / 1y	Brake			o				**
1000h / 1y	Electrical system: cables condition	o						**
1000h / 1y	Electrical system: Lighting and signalling	o						**
1000h / 1y	Electrical system: Acoustic signal devices	o						**
1000h / 1y	Hydraulic system: Jacks	o						**
1000h / 1y	Hydraulic system: Pipes and flexible pipes	o						**
1000h / 1y	Hydraulic system: Movements speed	o						**
1000h / 1y	Hydraulic oil					o		
1000h / 1y	Engine valves clearances	o						**
1000h / 1y	Engine speeds	o						**
1000h / 1y	Fuel tank				o			
1000h / 1y	Drum gearbox oil					o		
1000h / 1y	Chassis: bearings and pivot bushes	o						**
1000h / 1y	Chassis: structure	o						**
1000h / 1y	Transmission oil					o		

Maintenance								
2000h	Axles oscillation	o						**
2000h	Hydraulic system: Capacity	o						**
2000h	Hydraulic system: Pressures	o						**
2000h	Hydraulic oil tank				o			**
2000h	Alternator and Starter motor	o						**
2000h	Radiators	o			o			**
3000h	Diesel exhaust fluid filter					o		
3000h	Coolant					o		
3600h	Engine AdBlue tank filter					o		**
4000h	Prop shafts	o				o		**
4000h	Reduction gears universal joint	o						**
4000h	Wheels reduction gear clearance	o						**
4000h	Steering ball joints	o						**
4000h	Wheels reduction gear pins	o						**
4000h	Brakes wear	o						**
10000h	DEF collector filter					o		
2y	Air conditioning system (if installed): Dissipater filter					o		**
2y	Air conditioning system (if installed): Oil refrigerant	o						**
2y	Air conditioning system (if installed): Pressure switches	o		o				**
2y	Air conditioning system (if installed): Condenser and evaporator coils				o			**
2y	Air conditioning system (if installed): Condensate and exhaust valve tank				o			**
Notes		Stamp and signature						

MAINTENANCE LOG			
Maintenance sheet no.	Maintenance date
Vehicle serial number:	Maintenance technician name
Vehicle hours	Maintenance company name







	Maintenance							
0h	Air conditioning system	<input type="radio"/>			<input type="radio"/>			
0h	Filters (air, engine oil, hydraulic oil, fuel, air conditioning system, cab)	<input type="radio"/>						
0h	Brake			<input type="radio"/>				
0h	Parking brake	<input type="radio"/>						
0h	Electrolyte level and battery charge	<input type="radio"/>						
0h	Lighting	<input type="radio"/>						
0h	Hydraulic oil level	<input type="radio"/>						
0h	Alternator belts \ services	<input type="radio"/>						
0h	Engine oil level	<input type="radio"/>						
0h	Radiators	<input type="radio"/>			<input type="radio"/>			
0h	Radiator expansion tank	<input type="radio"/>	<input type="radio"/>					
0h	Tyre pressure	<input type="radio"/>						
0h	Wear check (on both the vehicle and equipment if installed)	<input type="radio"/>						
10h / 1m	Window washer tank	<input type="radio"/>	<input type="radio"/>					
10h / 1m	Safety stickers	<input type="radio"/>						
10h / 1m	Safety devices	<input type="radio"/>						
10h / 1m	Coolant	<input type="radio"/>						
10h / 1m	Engine oil level	<input type="radio"/>						
10h / 1m	Metal structural work, no cracks	<input type="radio"/>						
10h / 1m	Radiators				<input type="radio"/>			
50h / 1m	Grease level in the automatic lubrication system (if installed)							<input type="radio"/>
50h / 1m	Prop shafts							<input type="radio"/>
50h / 1m	Axles oscillation							<input type="radio"/>
50h / 1m	Wheels reduction gear pins							<input type="radio"/>
50h / 1m	Mechanical joints of parking brake on the axle							<input type="radio"/>
50h / 1m	Mechanical joints							<input type="radio"/>
50h / 1m	Cab ventilation filter (if the closed cab option is present)				<input type="radio"/>			
50h / 1m	Brakes oil level	<input type="radio"/>						
50h / 1m	Hydraulic oil level	<input type="radio"/>						
50h / 1m	Hydraulic system leaks	<input type="radio"/>						
50h / 1m	Air filter				<input type="radio"/>			
50h / 1m	Fuel filter				<input type="radio"/>			
50h / 1m	Coolant	<input type="radio"/>						
50h / 1m	Engine oil level	<input type="radio"/>						
50h / 1m	Tyre pressure	<input type="radio"/>						







Maintenance								
50h / 1m	Wheel nuts tightening	o						
250h / 2m	Seat belts	o						
250h / 2m	Rear view mirrors	o						
250h / 2m	Electrolyte level and battery charge	o						
250h / 2m	Torque specifications - Hydraulic Fittings			o				
250h / 2m	Alternator belts \ services	o		o				
250h / 2m	Torque specifications - fasteners			o				
250h	Transmission oil					o		
250h	Differential axle oil					o		
250h	Epicycloidal reduction gear oil					o		
500h / 6m	Differential axle oil	o						
500h / 6m	Epicycloidal reduction gear oil	o						
500h / 6m	Cab ventilation filter (if the closed cab option is present)					o		
500h / 6m	Brakes oil					o		
500h / 6m	Electrical system	o						
500h / 6m	Hydraulic oil filter(s)					o		
500h / 6m	Air filter					o		
500h / 6m	Engine fuel filter					o		
500h / 6m	Engine oil filter					o		
500h / 6m	Engine oil					o		
500h / 6m	Drum gearbox oil	o						
500h / 6m	Transmission oil	o						
500h / 1y	Water separator filter					o		
1000h / 1y	Differential axle oil					o		
1000h / 1y	Epicycloidal reduction gear oil					o		
1000h / 1y	Cab structure	o						**
1000h / 1y	Brakes oil circuit				o			**
1000h / 1y	Brakes oil circuit: Pressure	o						**
1000h / 1y	Brake			o				**
1000h / 1y	Electrical system: cables condition	o						**
1000h / 1y	Electrical system: Lighting and signalling	o						**
1000h / 1y	Electrical system: Acoustic signal devices	o						**
1000h / 1y	Hydraulic system: Jacks	o						**
1000h / 1y	Hydraulic system: Pipes and flexible pipes	o						**







Maintenance								
1000h / 1y	Hydraulic system: Movements speed	o						**
1000h / 1y	Hydraulic oil					o		
1000h / 1y	Engine valves clearances	o						**
1000h / 1y	Engine speeds	o						**
1000h / 1y	Fuel tank				o			
1000h / 1y	Drum gearbox oil					o		
1000h / 1y	Chassis: bearings and pivot bushes	o						**
1000h / 1y	Chassis: structure	o						**
1000h / 1y	Transmission oil					o		
2000h	Axles oscillation	o						**
2000h	Hydraulic system: Capacity	o						**
2000h	Hydraulic system: Pressures	o						**
2000h	Hydraulic oil tank				o			**
2000h	Alternator and Starter motor	o						**
2000h	Radiators	o			o			**
3000h	Diesel exhaust fluid filter					o		
3000h	Coolant					o		
3600h	Engine AdBlue tank filter					o		**
4000h	Prop shafts	o				o		**
4000h	Reduction gears universal joint	o						**
4000h	Wheels reduction gear clearance	o						**
4000h	Steering ball joints	o						**
4000h	Wheels reduction gear pins	o						**
4000h	Brakes wear	o						**
10000h	DEF collector filter					o		
2y	Air conditioning system (if installed): Dissipater filter					o		**
2y	Air conditioning system (if installed): Oil refrigerant	o						**
2y	Air conditioning system (if installed): Pressure switches	o		o				**
2y	Air conditioning system (if installed): Condenser and evaporator coils				o			**
2y	Air conditioning system (if installed): Condensate and exhaust valve tank				o			**

Notes	Stamp and signature

MAINTENANCE LOG			
Maintenance sheet no.	Maintenance date
Vehicle serial number:	Maintenance technician name
Vehicle hours	Maintenance company name







	Maintenance							
0h	Air conditioning system	o			o			
0h	Filters (air, engine oil, hydraulic oil, fuel, air conditioning system, cab)	o						
0h	Brake			o				
0h	Parking brake	o						
0h	Electrolyte level and battery charge	o						
0h	Lighting	o						
0h	Hydraulic oil level	o						
0h	Alternator belts \ services	o						
0h	Engine oil level	o						
0h	Radiators	o			o			
0h	Radiator expansion tank	o	o					
0h	Tyre pressure	o						
0h	Wear check (on both the vehicle and equipment if installed)	o						
10h / 1m	Window washer tank	o	o					
10h / 1m	Safety stickers	o						
10h / 1m	Safety devices	o						
10h / 1m	Coolant	o						
10h / 1m	Engine oil level	o						
10h / 1m	Metal structural work, no cracks	o						
10h / 1m	Radiators				o			
50h / 1m	Grease level in the automatic lubrication system (if installed)						o	
50h / 1m	Prop shafts						o	
50h / 1m	Axles oscillation						o	
50h / 1m	Wheels reduction gear pins						o	
50h / 1m	Mechanical joints of parking brake on the axle						o	
50h / 1m	Mechanical joints						o	
50h / 1m	Cab ventilation filter (if the closed cab option is present)				o			
50h / 1m	Brakes oil level	o						
50h / 1m	Hydraulic oil level	o						
50h / 1m	Hydraulic system leaks	o						
50h / 1m	Air filter				o			
50h / 1m	Fuel filter				o			
50h / 1m	Coolant	o						
50h / 1m	Engine oil level	o						
50h / 1m	Tyre pressure	o						

	Maintenance							
50h / 1m	Wheel nuts tightening	o						
250h / 2m	Seat belts	o						
250h / 2m	Rear view mirrors	o						
250h / 2m	Electrolyte level and battery charge	o						
250h / 2m	Torque specifications - Hydraulic Fittings			o				
250h / 2m	Alternator belts \ services	o		o				
250h / 2m	Torque specifications - fasteners			o				
250h	Transmission oil					o		
250h	Differential axle oil					o		
250h	Epicycloidal reduction gear oil					o		
500h / 6m	Differential axle oil	o						
500h / 6m	Epicycloidal reduction gear oil	o						
500h / 6m	Cab ventilation filter (if the closed cab option is present)					o		
500h / 6m	Brakes oil					o		
500h / 6m	Electrical system	o						
500h / 6m	Hydraulic oil filter(s)					o		
500h / 6m	Air filter					o		
500h / 6m	Engine fuel filter					o		
500h / 6m	Engine oil filter					o		
500h / 6m	Engine oil					o		
500h / 6m	Drum gearbox oil	o						
500h / 6m	Transmission oil	o						
500h / 1y	Water separator filter					o		
1000h / 1y	Differential axle oil					o		
1000h / 1y	Epicycloidal reduction gear oil					o		
1000h / 1y	Cab structure	o						**
1000h / 1y	Brakes oil circuit				o			**
1000h / 1y	Brakes oil circuit: Pressure	o						**
1000h / 1y	Brake			o				**
1000h / 1y	Electrical system: cables condition	o						**
1000h / 1y	Electrical system: Lighting and signalling	o						**
1000h / 1y	Electrical system: Acoustic signal devices	o						**
1000h / 1y	Hydraulic system: Jacks	o						**
1000h / 1y	Hydraulic system: Pipes and flexible pipes	o						**
1000h / 1y	Hydraulic system: Movements speed	o						**
1000h / 1y	Hydraulic oil					o		
1000h / 1y	Engine valves clearances	o						**
1000h / 1y	Engine speeds	o						**
1000h / 1y	Fuel tank				o			
1000h / 1y	Drum gearbox oil					o		
1000h / 1y	Chassis: bearings and pivot bushes	o						**
1000h / 1y	Chassis: structure	o						**
1000h / 1y	Transmission oil					o		

Maintenance								
2000h	Axles oscillation	o						**
2000h	Hydraulic system: Capacity	o						**
2000h	Hydraulic system: Pressures	o						**
2000h	Hydraulic oil tank				o			**
2000h	Alternator and Starter motor	o						**
2000h	Radiators	o			o			**
3000h	Diesel exhaust fluid filter					o		
3000h	Coolant					o		
3600h	Engine AdBlue tank filter					o		**
4000h	Prop shafts	o				o		**
4000h	Reduction gears universal joint	o						**
4000h	Wheels reduction gear clearance	o						**
4000h	Steering ball joints	o						**
4000h	Wheels reduction gear pins	o						**
4000h	Brakes wear	o						**
10000h	DEF collector filter					o		
2y	Air conditioning system (if installed): Dissipater filter					o		**
2y	Air conditioning system (if installed): Oil refrigerant	o						**
2y	Air conditioning system (if installed): Pressure switches	o		o				**
2y	Air conditioning system (if installed): Condenser and evaporator coils				o			**
2y	Air conditioning system (if installed): Condensate and exhaust valve tank				o			**
Notes		Stamp and signature						

MAINTENANCE LOG			
Maintenance sheet no.	Maintenance date
Vehicle serial number:	Maintenance technician name
Vehicle hours	Maintenance company name







	Maintenance							
0h	Air conditioning system	<input type="radio"/>			<input type="radio"/>			
0h	Filters (air, engine oil, hydraulic oil, fuel, air conditioning system, cab)	<input type="radio"/>						
0h	Brake			<input type="radio"/>				
0h	Parking brake	<input type="radio"/>						
0h	Electrolyte level and battery charge	<input type="radio"/>						
0h	Lighting	<input type="radio"/>						
0h	Hydraulic oil level	<input type="radio"/>						
0h	Alternator belts \ services	<input type="radio"/>						
0h	Engine oil level	<input type="radio"/>						
0h	Radiators	<input type="radio"/>			<input type="radio"/>			
0h	Radiator expansion tank	<input type="radio"/>	<input type="radio"/>					
0h	Tyre pressure	<input type="radio"/>						
0h	Wear check (on both the vehicle and equipment if installed)	<input type="radio"/>						
10h / 1m	Window washer tank	<input type="radio"/>	<input type="radio"/>					
10h / 1m	Safety stickers	<input type="radio"/>						
10h / 1m	Safety devices	<input type="radio"/>						
10h / 1m	Coolant	<input type="radio"/>						
10h / 1m	Engine oil level	<input type="radio"/>						
10h / 1m	Metal structural work, no cracks	<input type="radio"/>						
10h / 1m	Radiators				<input type="radio"/>			
50h / 1m	Grease level in the automatic lubrication system (if installed)							<input type="radio"/>
50h / 1m	Prop shafts							<input type="radio"/>
50h / 1m	Axles oscillation							<input type="radio"/>
50h / 1m	Wheels reduction gear pins							<input type="radio"/>
50h / 1m	Mechanical joints of parking brake on the axle							<input type="radio"/>
50h / 1m	Mechanical joints							<input type="radio"/>
50h / 1m	Cab ventilation filter (if the closed cab option is present)				<input type="radio"/>			
50h / 1m	Brakes oil level	<input type="radio"/>						
50h / 1m	Hydraulic oil level	<input type="radio"/>						
50h / 1m	Hydraulic system leaks	<input type="radio"/>						
50h / 1m	Air filter				<input type="radio"/>			
50h / 1m	Fuel filter				<input type="radio"/>			
50h / 1m	Coolant	<input type="radio"/>						
50h / 1m	Engine oil level	<input type="radio"/>						
50h / 1m	Tyre pressure	<input type="radio"/>						

Maintenance								
50h / 1m	Wheel nuts tightening	o						
250h / 2m	Seat belts	o						
250h / 2m	Rear view mirrors	o						
250h / 2m	Electrolyte level and battery charge	o						
250h / 2m	Torque specifications - Hydraulic Fittings			o				
250h / 2m	Alternator belts \ services	o		o				
250h / 2m	Torque specifications - fasteners			o				
250h	Transmission oil					o		
250h	Differential axle oil					o		
250h	Epicycloidal reduction gear oil					o		
500h / 6m	Differential axle oil	o						
500h / 6m	Epicycloidal reduction gear oil	o						
500h / 6m	Cab ventilation filter (if the closed cab option is present)					o		
500h / 6m	Brakes oil					o		
500h / 6m	Electrical system	o						
500h / 6m	Hydraulic oil filter(s)					o		
500h / 6m	Air filter					o		
500h / 6m	Engine fuel filter					o		
500h / 6m	Engine oil filter					o		
500h / 6m	Engine oil					o		
500h / 6m	Drum gearbox oil	o						
500h / 6m	Transmission oil	o						
500h / 1y	Water separator filter					o		
1000h / 1y	Differential axle oil					o		
1000h / 1y	Epicycloidal reduction gear oil					o		
1000h / 1y	Cab structure	o						**
1000h / 1y	Brakes oil circuit				o			**
1000h / 1y	Brakes oil circuit: Pressure	o						**
1000h / 1y	Brake			o				**
1000h / 1y	Electrical system: cables condition	o						**
1000h / 1y	Electrical system: Lighting and signalling	o						**
1000h / 1y	Electrical system: Acoustic signal devices	o						**
1000h / 1y	Hydraulic system: Jacks	o						**
1000h / 1y	Hydraulic system: Pipes and flexible pipes	o						**







Maintenance								
1000h / 1y	Hydraulic system: Movements speed	o						**
1000h / 1y	Hydraulic oil					o		
1000h / 1y	Engine valves clearances	o						**
1000h / 1y	Engine speeds	o						**
1000h / 1y	Fuel tank				o			
1000h / 1y	Drum gearbox oil					o		
1000h / 1y	Chassis: bearings and pivot bushes	o						**
1000h / 1y	Chassis: structure	o						**
1000h / 1y	Transmission oil					o		
2000h	Axles oscillation	o						**
2000h	Hydraulic system: Capacity	o						**
2000h	Hydraulic system: Pressures	o						**
2000h	Hydraulic oil tank				o			**
2000h	Alternator and Starter motor	o						**
2000h	Radiators	o			o			**
3000h	Diesel exhaust fluid filter					o		
3000h	Coolant					o		
3600h	Engine AdBlue tank filter					o		**
4000h	Prop shafts	o				o		**
4000h	Reduction gears universal joint	o						**
4000h	Wheels reduction gear clearance	o						**
4000h	Steering ball joints	o						**
4000h	Wheels reduction gear pins	o						**
4000h	Brakes wear	o						**
10000h	DEF collector filter					o		
2y	Air conditioning system (if installed): Dissipater filter					o		**
2y	Air conditioning system (if installed): Oil refrigerant	o						**
2y	Air conditioning system (if installed): Pressure switches	o		o				**
2y	Air conditioning system (if installed): Condenser and evaporator coils				o			**
2y	Air conditioning system (if installed): Condensate and exhaust valve tank				o			**

Notes	Stamp and signature

MAINTENANCE LOG			
Maintenance sheet no.	Maintenance date
Vehicle serial number:	Maintenance technician name
Vehicle hours	Maintenance company name







	Maintenance							
0h	Air conditioning system	o			o			
0h	Filters (air, engine oil, hydraulic oil, fuel, air conditioning system, cab)	o						
0h	Brake			o				
0h	Parking brake	o						
0h	Electrolyte level and battery charge	o						
0h	Lighting	o						
0h	Hydraulic oil level	o						
0h	Alternator belts \ services	o						
0h	Engine oil level	o						
0h	Radiators	o			o			
0h	Radiator expansion tank	o	o					
0h	Tyre pressure	o						
0h	Wear check (on both the vehicle and equipment if installed)	o						
10h / 1m	Window washer tank	o	o					
10h / 1m	Safety stickers	o						
10h / 1m	Safety devices	o						
10h / 1m	Coolant	o						
10h / 1m	Engine oil level	o						
10h / 1m	Metal structural work, no cracks	o						
10h / 1m	Radiators				o			
50h / 1m	Grease level in the automatic lubrication system (if installed)							o
50h / 1m	Prop shafts							o
50h / 1m	Axles oscillation							o
50h / 1m	Wheels reduction gear pins							o
50h / 1m	Mechanical joints of parking brake on the axle							o
50h / 1m	Mechanical joints							o
50h / 1m	Cab ventilation filter (if the closed cab option is present)				o			
50h / 1m	Brakes oil level	o						
50h / 1m	Hydraulic oil level	o						
50h / 1m	Hydraulic system leaks	o						
50h / 1m	Air filter				o			
50h / 1m	Fuel filter				o			
50h / 1m	Coolant	o						
50h / 1m	Engine oil level	o						
50h / 1m	Tyre pressure	o						

	Maintenance							
50h / 1m	Wheel nuts tightening	o						
250h / 2m	Seat belts	o						
250h / 2m	Rear view mirrors	o						
250h / 2m	Electrolyte level and battery charge	o						
250h / 2m	Torque specifications - Hydraulic Fittings			o				
250h / 2m	Alternator belts \ services	o		o				
250h / 2m	Torque specifications - fasteners			o				
250h	Transmission oil					o		
250h	Differential axle oil					o		
250h	Epicycloidal reduction gear oil					o		
500h / 6m	Differential axle oil	o						
500h / 6m	Epicycloidal reduction gear oil	o						
500h / 6m	Cab ventilation filter (if the closed cab option is present)					o		
500h / 6m	Brakes oil					o		
500h / 6m	Electrical system	o						
500h / 6m	Hydraulic oil filter(s)					o		
500h / 6m	Air filter					o		
500h / 6m	Engine fuel filter					o		
500h / 6m	Engine oil filter					o		
500h / 6m	Engine oil					o		
500h / 6m	Drum gearbox oil	o						
500h / 6m	Transmission oil	o						
500h / 1y	Water separator filter					o		
1000h / 1y	Differential axle oil					o		
1000h / 1y	Epicycloidal reduction gear oil					o		
1000h / 1y	Cab structure	o						**
1000h / 1y	Brakes oil circuit				o			**
1000h / 1y	Brakes oil circuit: Pressure	o						**
1000h / 1y	Brake			o				**
1000h / 1y	Electrical system: cables condition	o						**
1000h / 1y	Electrical system: Lighting and signalling	o						**
1000h / 1y	Electrical system: Acoustic signal devices	o						**
1000h / 1y	Hydraulic system: Jacks	o						**
1000h / 1y	Hydraulic system: Pipes and flexible pipes	o						**
1000h / 1y	Hydraulic system: Movements speed	o						**
1000h / 1y	Hydraulic oil					o		
1000h / 1y	Engine valves clearances	o						**
1000h / 1y	Engine speeds	o						**
1000h / 1y	Fuel tank				o			
1000h / 1y	Drum gearbox oil					o		
1000h / 1y	Chassis: bearings and pivot bushes	o						**
1000h / 1y	Chassis: structure	o						**
1000h / 1y	Transmission oil					o		

Maintenance								
2000h	Axles oscillation	o						**
2000h	Hydraulic system: Capacity	o						**
2000h	Hydraulic system: Pressures	o						**
2000h	Hydraulic oil tank				o			**
2000h	Alternator and Starter motor	o						**
2000h	Radiators	o			o			**
3000h	Diesel exhaust fluid filter					o		
3000h	Coolant					o		
3600h	Engine AdBlue tank filter					o		**
4000h	Prop shafts	o				o		**
4000h	Reduction gears universal joint	o						**
4000h	Wheels reduction gear clearance	o						**
4000h	Steering ball joints	o						**
4000h	Wheels reduction gear pins	o						**
4000h	Brakes wear	o						**
10000h	DEF collector filter					o		
2y	Air conditioning system (if installed): Dissipater filter					o		**
2y	Air conditioning system (if installed): Oil refrigerant	o						**
2y	Air conditioning system (if installed): Pressure switches	o		o				**
2y	Air conditioning system (if installed): Condenser and evaporator coils				o			**
2y	Air conditioning system (if installed): Condensate and exhaust valve tank				o			**
Notes		Stamp and signature						

MAINTENANCE LOG			
Maintenance sheet no.	Maintenance date
Vehicle serial number:	Maintenance technician name
Vehicle hours	Maintenance company name

	Maintenance							
0h	Air conditioning system	<input type="radio"/>			<input type="radio"/>			
0h	Filters (air, engine oil, hydraulic oil, fuel, air conditioning system, cab)	<input type="radio"/>						
0h	Brake			<input type="radio"/>				
0h	Parking brake	<input type="radio"/>						
0h	Electrolyte level and battery charge	<input type="radio"/>						
0h	Lighting	<input type="radio"/>						
0h	Hydraulic oil level	<input type="radio"/>						
0h	Alternator belts \ services	<input type="radio"/>						
0h	Engine oil level	<input type="radio"/>						
0h	Radiators	<input type="radio"/>			<input type="radio"/>			
0h	Radiator expansion tank	<input type="radio"/>	<input type="radio"/>					
0h	Tyre pressure	<input type="radio"/>						
0h	Wear check (on both the vehicle and equipment if installed)	<input type="radio"/>						
10h / 1m	Window washer tank	<input type="radio"/>	<input type="radio"/>					
10h / 1m	Safety stickers	<input type="radio"/>						
10h / 1m	Safety devices	<input type="radio"/>						
10h / 1m	Coolant	<input type="radio"/>						
10h / 1m	Engine oil level	<input type="radio"/>						
10h / 1m	Metal structural work, no cracks	<input type="radio"/>						
10h / 1m	Radiators				<input type="radio"/>			
50h / 1m	Grease level in the automatic lubrication system (if installed)							<input type="radio"/>
50h / 1m	Prop shafts							<input type="radio"/>
50h / 1m	Axles oscillation							<input type="radio"/>
50h / 1m	Wheels reduction gear pins							<input type="radio"/>
50h / 1m	Mechanical joints of parking brake on the axle							<input type="radio"/>
50h / 1m	Mechanical joints							<input type="radio"/>
50h / 1m	Cab ventilation filter (if the closed cab option is present)				<input type="radio"/>			
50h / 1m	Brakes oil level	<input type="radio"/>						
50h / 1m	Hydraulic oil level	<input type="radio"/>						
50h / 1m	Hydraulic system leaks	<input type="radio"/>						
50h / 1m	Air filter				<input type="radio"/>			
50h / 1m	Fuel filter				<input type="radio"/>			
50h / 1m	Coolant	<input type="radio"/>						
50h / 1m	Engine oil level	<input type="radio"/>						
50h / 1m	Tyre pressure	<input type="radio"/>						

Maintenance								
50h / 1m	Wheel nuts tightening	o						
250h / 2m	Seat belts	o						
250h / 2m	Rear view mirrors	o						
250h / 2m	Electrolyte level and battery charge	o						
250h / 2m	Torque specifications - Hydraulic Fittings			o				
250h / 2m	Alternator belts \ services	o		o				
250h / 2m	Torque specifications - fasteners			o				
250h	Transmission oil					o		
250h	Differential axle oil					o		
250h	Epicycloidal reduction gear oil					o		
500h / 6m	Differential axle oil	o						
500h / 6m	Epicycloidal reduction gear oil	o						
500h / 6m	Cab ventilation filter (if the closed cab option is present)					o		
500h / 6m	Brakes oil					o		
500h / 6m	Electrical system	o						
500h / 6m	Hydraulic oil filter(s)					o		
500h / 6m	Air filter					o		
500h / 6m	Engine fuel filter					o		
500h / 6m	Engine oil filter					o		
500h / 6m	Engine oil					o		
500h / 6m	Drum gearbox oil	o						
500h / 6m	Transmission oil	o						
500h / 1y	Water separator filter					o		
1000h / 1y	Differential axle oil					o		
1000h / 1y	Epicycloidal reduction gear oil					o		
1000h / 1y	Cab structure	o						**
1000h / 1y	Brakes oil circuit				o			**
1000h / 1y	Brakes oil circuit: Pressure	o						**
1000h / 1y	Brake			o				**
1000h / 1y	Electrical system: cables condition	o						**
1000h / 1y	Electrical system: Lighting and signalling	o						**
1000h / 1y	Electrical system: Acoustic signal devices	o						**
1000h / 1y	Hydraulic system: Jacks	o						**
1000h / 1y	Hydraulic system: Pipes and flexible pipes	o						**

Maintenance								
1000h / 1y	Hydraulic system: Movements speed	o						**
1000h / 1y	Hydraulic oil					o		
1000h / 1y	Engine valves clearances	o						**
1000h / 1y	Engine speeds	o						**
1000h / 1y	Fuel tank				o			
1000h / 1y	Drum gearbox oil					o		
1000h / 1y	Chassis: bearings and pivot bushes	o						**
1000h / 1y	Chassis: structure	o						**
1000h / 1y	Transmission oil					o		
2000h	Axles oscillation	o						**
2000h	Hydraulic system: Capacity	o						**
2000h	Hydraulic system: Pressures	o						**
2000h	Hydraulic oil tank				o			**
2000h	Alternator and Starter motor	o						**
2000h	Radiators	o			o			**
3000h	Diesel exhaust fluid filter					o		
3000h	Coolant					o		
3600h	Engine AdBlue tank filter					o		**
4000h	Prop shafts	o				o		**
4000h	Reduction gears universal joint	o						**
4000h	Wheels reduction gear clearance	o						**
4000h	Steering ball joints	o						**
4000h	Wheels reduction gear pins	o						**
4000h	Brakes wear	o						**
10000h	DEF collector filter					o		
2y	Air conditioning system (if installed): Dissipater filter					o		**
2y	Air conditioning system (if installed): Oil refrigerant	o						**
2y	Air conditioning system (if installed): Pressure switches	o		o				**
2y	Air conditioning system (if installed): Condenser and evaporator coils				o			**
2y	Air conditioning system (if installed): Condensate and exhaust valve tank				o			**

Notes	Stamp and signature

